



This document is brought to you through the kind services of

Kevin Wright

krwright@wankel.net

<http://www.wankel.net/~krwright>

who, well, didn't do much this time, since Paul Lee provided the thing already scanned and compiled into a PDF! (Thanks!). Go visit his website: <http://www.iluvmyrx7.com/index.htm> Lots of RX-7 goodness there.

There are several ways to get around in the document. I have provided Bookmarks to all the sections, and thumbnails are also provided in the Thumbnails side bar.

I have also included a label for the spine of a binder, for those who wish to print out all the pages and keep a dead-tree edition handy.☺

The original document is © 1979 Toyo Kogyo Co., Ltd., and remains so. This version is provided as a service for owners of first generation Mazda RX-7s who are having a devil of a time locating the factory service manual for a reasonable price.

If you really want to send me money, email me and I'll tell you where to send it, but it's not necessary. Consider this payback for all the good advice and information gleaned from the various RX-7 email lists!

Subscribe to the Early Mazda Rotaries email list:

Send an email with "subscribe" (without the quotes) to list-request@sa22c.org

See <http://www.dfw-rx7.com> for information on the DFW-RX7 email list.

09/16/03

ELECTRICAL SYSTEM (BODY)

15-A. RETRACTABLE HEADLIGHT	15 : 1
15-A-1. Replacing Retractable Headlight.....	15 : 1
15-A-2. Adjusting Headlight Aim.....	15 : 1
15-A-3. Replacing Retractor Hinge.....	15 : 2
15-A-4. Replacing Retractor Motor and Linkage Assembly.....	15 : 2
15-A-5. Adjusting Headlight Lid	15 : 3
15-B. WINDSHIELD WIPER MOTOR.....	15 : 3
15-B-1. Removing Wiper Motor.....	15 : 3
15-B-2. Installing Wiper Motor	15 : 4
15-B-3. Checking Wiper Motor	15 : 4
15-C. HORN.....	15 : 4
15-C-1. Removing Horn	15 : 4
15-C-2. Adjusting Horn	15 : 5
15-D. REAR WINDOW DEFROSTER.....	15 : 5
15-D-1. Checking Rear Window Defroster.....	15 : 5
15-D-2. Repairing Printed Filament	15 : 5
15-E. FUEL AND WATER TEMPERATURE GAUGES ..	15 : 5
15-E-1. Checking Fuel Gauge	15 : 5
15-E-2. Checking Water Temperature Gauge.....	15 : 6
15-E-3. Checking Fuel Gauge Unit	15 : 6
15-E-4. Replacing Fuel and Water Temperature Gauge	15 : 7
15-F. COMBINATION METER.....	15 : 7
15-F-1. Removing Combination Meter	15 : 7
15-F-2. Checking Combination Meter.....	15 : 8
15-G. COMBINATION SWITCH	15 : 9
15-G-1. Checking Combination Switch	15 : 9
15-G-2. Replacing Combination Switch.....	15 : 9
15-H. IGNITION SWITCH & STEERING LOCK	15 : 10
15-I. HEATER FAN SWITCH INSPECTION.....	15 : 10
15-J. INHIBITOR SWITCH INSPECTION.....	15 : 10
15-K. RETRACTABLE HEADLIGHT SWITCH INSPECTION.....	15 : 10
15-L. CENTER PANEL.....	15 : 11
15-L-1. Removing Center Panel.....	15 : 11
15-L-2. Installing Center Panel	15 : 11

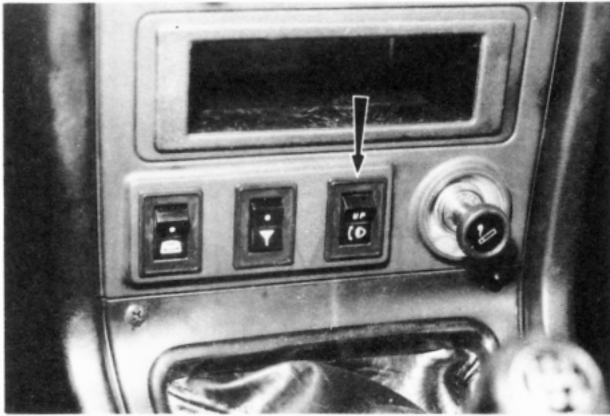

Fig. 15-1

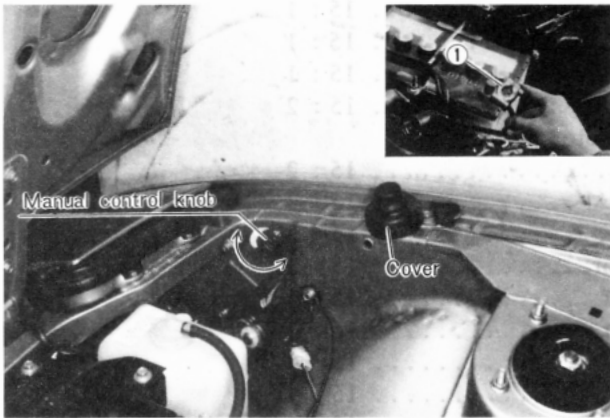

Fig. 15-2

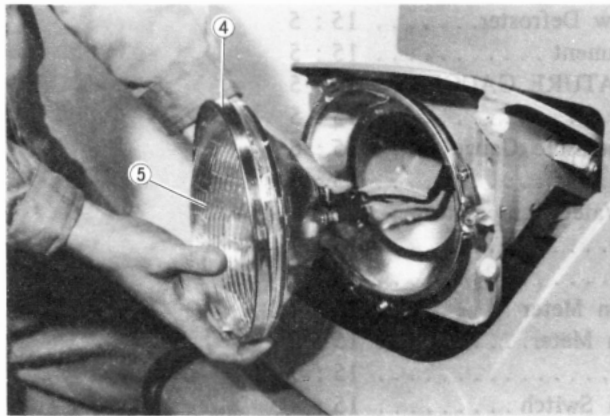

Fig. 15-3

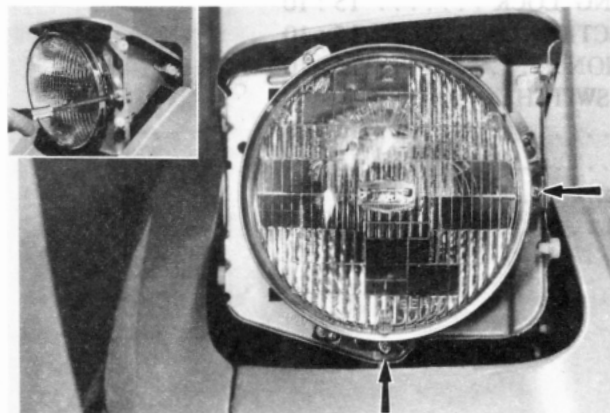

Fig. 15-4

15-A. RETRACTABLE HEADLIGHT

15-A-1. Replacing Retractable Headlight

1. Turn on the headlight retractor switch to raise the headlight in position.

Note:

Should the retractor do not operate automatically after the retractor switch has turned on, raise the headlight manually as follows;

1. Disconnect the battery negative cable.
2. Remove the cover and turn the manual control knob on the retractor motor shaft until the headlight is fully raised.

2. Disconnect the battery negative cable.
3. Remove the headlight bezel.
4. Loosen the headlight retaining ring attaching screws. Rotate the retaining ring counterclockwise and remove it while holding the headlight.
5. Take out the headlight and disconnect the electrical connector. Remove the headlight.
6. Install a new headlight in the reverse order of removing.
7. Adjust the headlight aim, referring to Par. 15-A-2.

15-A-2. Adjusting Headlight Aim

Before adjusting the headlights, make sure that the tires are inflated uniformly to recommended pressure and the vehicle is on the level ground without load. Adjust the headlights to meet the regulation of your country.

To adjust the headlights, turn the two adjusting screws until the headlight is properly aimed.

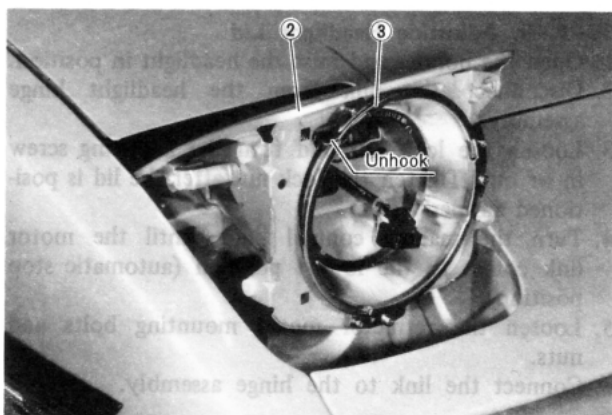

Fig. 15-5

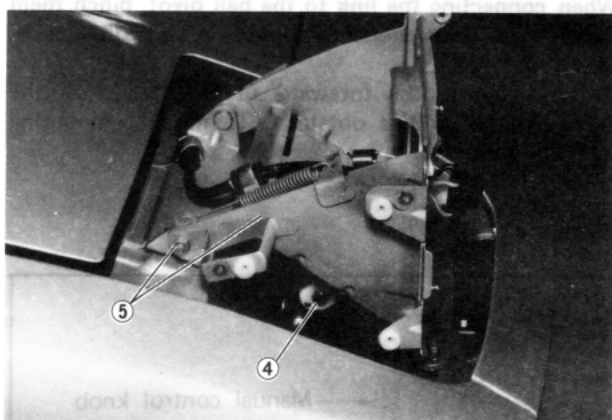

Fig. 15-6

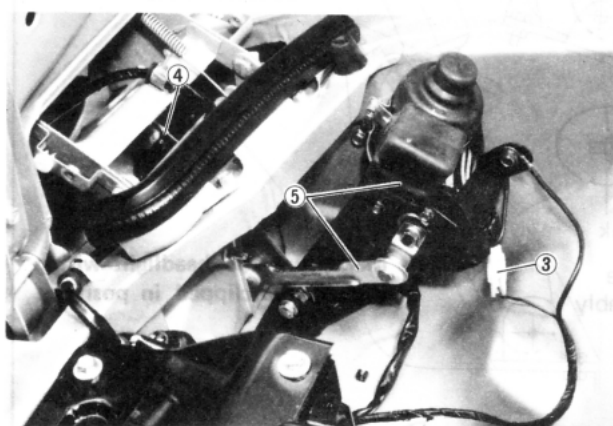

Fig. 15-7



Fig. 15-8

15-A-3. Replacing Retractor Hinge

1. Remove the headlight, referring to the Par. 15-A-1.
2. Remove the headlight lid.
3. Unhook the spring from the headlight mounting ring and take out the mounting ring.

4. Disconnect the link from hinge assembly.
5. Remove the hinge mounting nut and take out the hinge assembly.
6. Install the hinge assembly in the reverse order of removing.

Note:

- a) When connecting the link to the ball pivot, pinch them with fingers (not pliers) until there is an audible click.
- b) Whenever the retractor hinge assembly is replaced, make the up-down adjustment of the headlight lid, referring to Par. 15-A-5.

15-A-4. Replacing Retractor Motor and Linkage Assembly

1. Open the bonnet and raise the headlight in position.
2. Remove the headlight bezel.
3. Disconnect the electrical connector.
4. Disconnect the link from headlight hinge assembly.
5. Remove the retractor motor and linkage assembly.

5. If necessary, disassemble the retractor motor and linkage assembly.
6. Install the retractor motor and linkage assembly in the reverse order of removing.

Note:

Whenever the retractor motor and linkage assembly is replaced, make the up-down adjustment of the headlight, referring to the Par. 15-A-5.

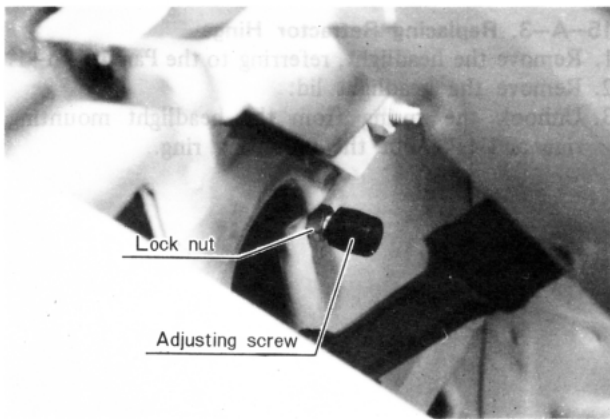

Fig. 15-9

15-A-5. Adjusting Headlight Lid

1. Open the bonnet and raise the headlight in position.
2. Disconnect the link from the headlight hinge assembly.
3. Loosen the lock nut and turn the adjusting screw in or out. Tighten the lock nut after the lid is positioned properly.
4. Turn the manual control knob until the motor link comes to the lowest position (automatic stop position).
5. Loosen the retractor motor mounting bolts and nuts.
6. Connect the link to the hinge assembly.

Note:

When connecting the link to the ball pivot, pinch them with fingers (not pliers) until there is an audible click.

7. Move the motor forward or rearward until the desired position is obtained. Tighten the mounting bolts and nuts.

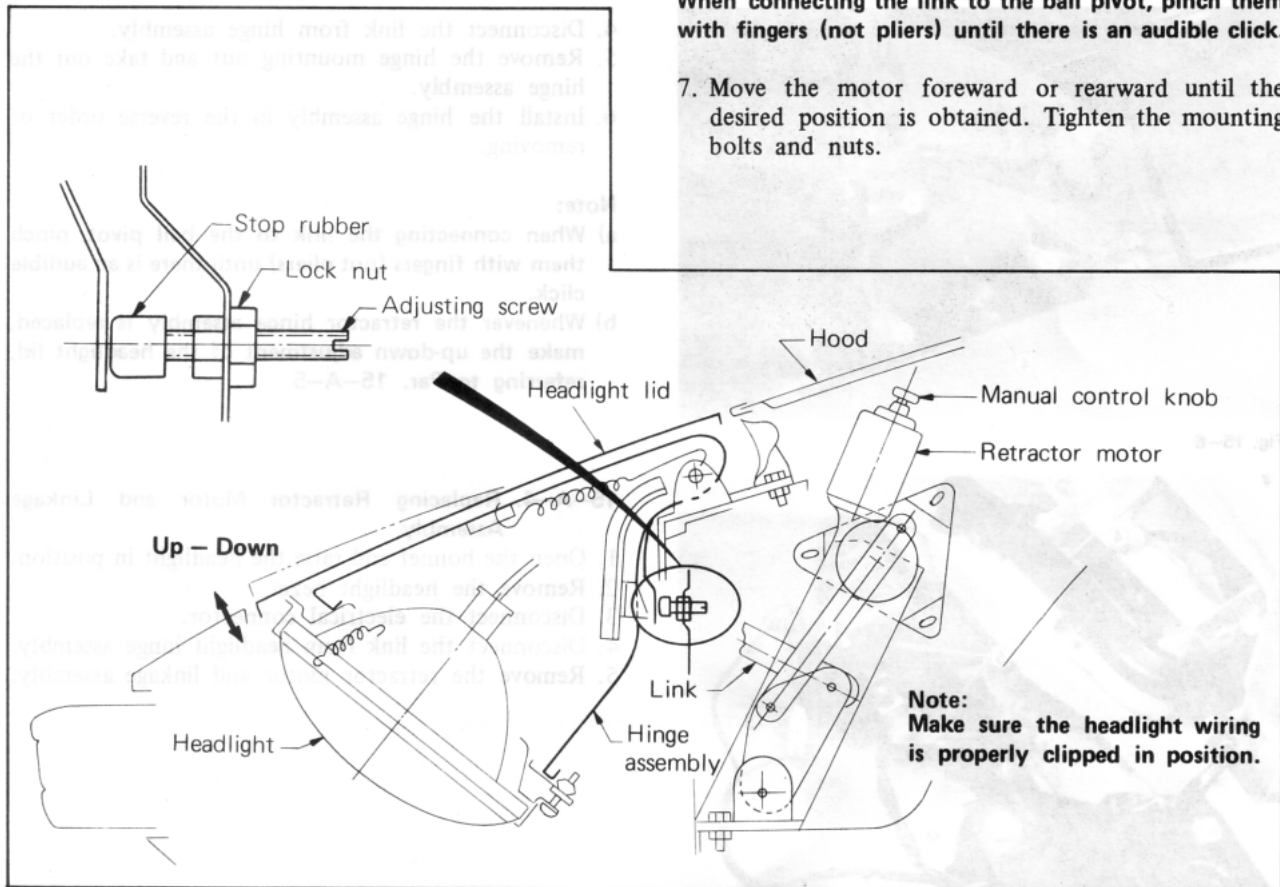

Fig. 15-10

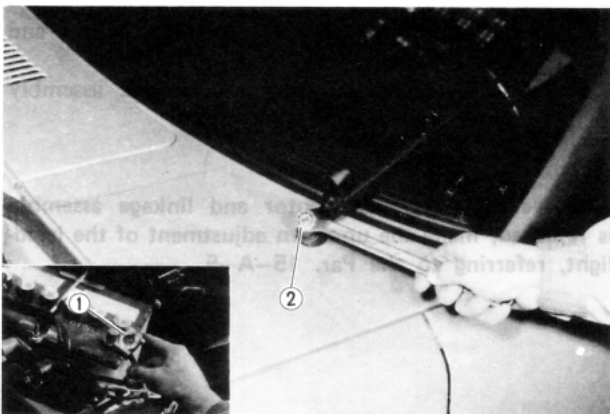

Fig. 15-11

15-B. WINDSHIELD WIPER MOTOR

15-B-1. Removing Wiper Motor

1. Operate the wiper motor and stop it so that the wiper blades stops at upper position by disconnect the battery negative cable.
2. Remove the wiper arms.
3. Remove the seal caps and then remove the nuts on the wiper linkage shaft.
4. Remove the cup washers and outer bushes.

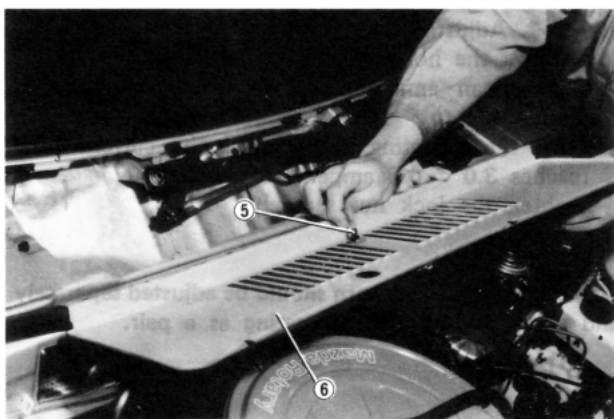

Fig. 15-12

5. Remove the cowl plate attaching screws and disconnect the washer hose at the washer nozzle.
6. Take out the cowl plate.

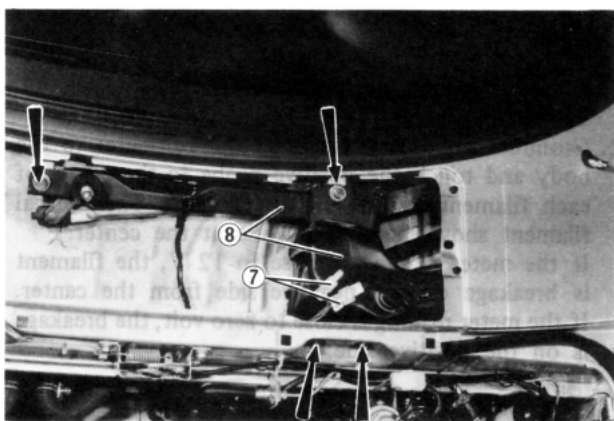

Fig. 15-13

7. Disconnect the wiring connectors at the wiper motor.
8. Remove the wiper motor and link assembly.

15-B-2. Installing Wiper Motor

Follow the removal procedures in the reverse order.



15-B-3. Checking Wiper Motor

Connect the wiper motor, ammeter and battery according to the left table, and check the number of wiping revolutions and amperage.

Wiper motor operation	Terminal ground	Battery positive power to	Remarks
High speed	A	D	Connect an ammeter between the battery and terminal D.
Low speed	C	D	
Auto stop	E	D	Connect jumper wire between terminal B and C.

		<p>A : LR E : B B : LB C : LW D : L</p>
--	--	---

	Wiping number	Amperage (No load)
LOW	43 ~ 60 rpm.	Less than 4A
HIGH	62 ~ 95 rpm.	Less than 4A

Note:

- a) The difference in number of revolutions between LOW and HIGH should be more than 15 RPM.
- b) To check the auto stop circuit, stop the wiper motor so that the blades stops at upper position when checking the low speed circuit.

15-C. HORN

15-C-1. Removing Horn

1. Remove the radiator grille.
2. Disconnect the connectors at the horn.
3. Remove the horn.

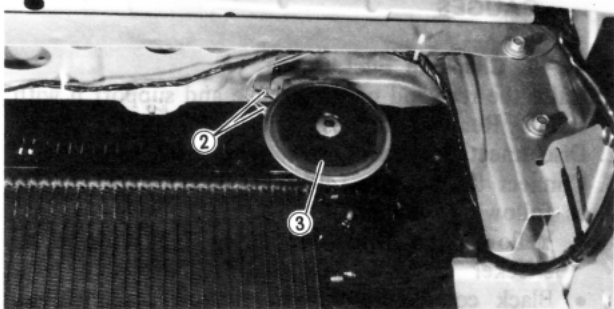

Fig. 15-14

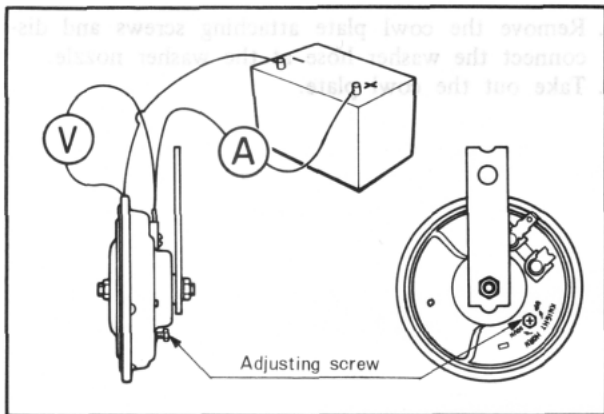

Fig. 15-15

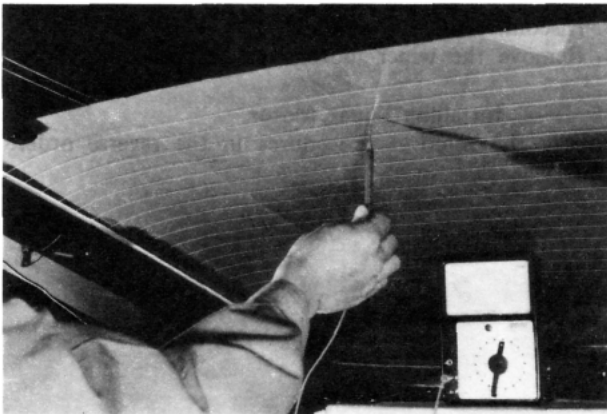

Fig. 15-16

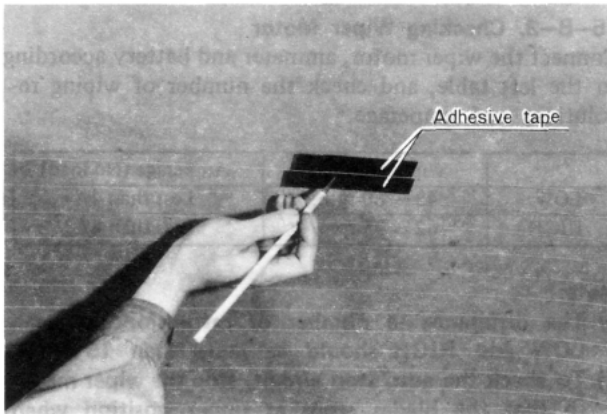

Fig. 15-17

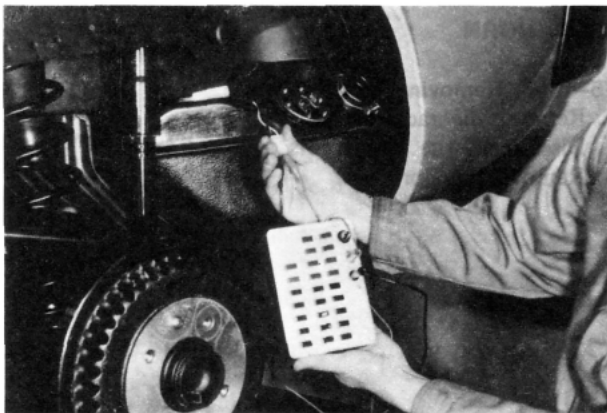

Fig. 15-18

15-C-2. Adjusting Horn

1. Remove the horn.
2. Connect an ammeter and voltmeter as shown in figure.
3. Turn the adjusting screw until the current flow reaches 3.0 ± 0.5 amperes at 12 volts. Tighten the lock nut securely.

Note:

When adjusting, each horn should be adjusted separately and check for tone by operating as a pair.

15-D. REAR WINDOW DEFROSTER

15-D-1. Checking Rear Window Defroster

1. Switch on the defroster switch.
2. Ground the negative probe of the voltmeter to the body and touch the positive probe to the center of each filament to measure the voltage. The normal filament shows approx. 6 volts at the center. If the meter reading is close to 12 V, the filament is breakage on the negative side from the center. If the meter reading is close to zero volt, the breakage is on the positive side.

15-D-2. Repairing Printed Filament

1. Clean the broken portion with solvent.
2. Apply an adhesive tape to the glass as shown in figure.
3. By using a small brush or drawing pen, coat conductive silver paint (Part No. 2835 77 600), i.e., Dupont No. 4817 to the broken portion.
4. Dry the painted portion completely by leaving it intact for 24 hours at 20°C (68°F) (for 30 minutes when the painted portion is heat up to 60°C (140°C) with a dryer).

Note:

- a) Never operate the heatable window before the paint has completely dried.
- b) Do not use any alkaline chemical cleanser to clean the portion thus repaired.

15-E. FUEL AND WATER TEMPERATURE GAUGES

15-E-1. Checking Fuel Gauge

1. Raise the rear end of the vehicle and support it with stands. Remove the rear left tire.
2. Disconnect the connector from the gauge unit.
3. Connect the checker (49 0839 285) to the coupler as following manner.
 - Yellow color wire terminal to \oplus terminal on checker
 - Black color wire terminal to \ominus terminal on checker

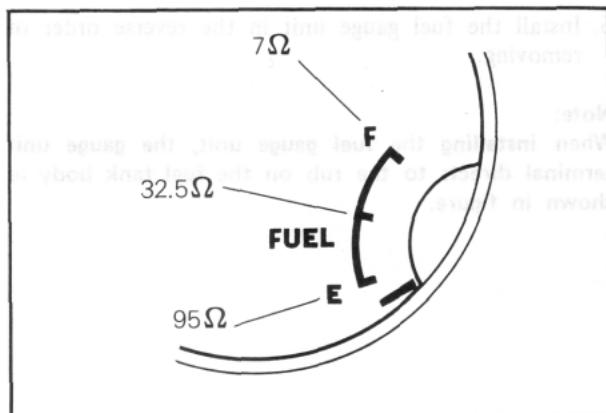

Fig. 15-19

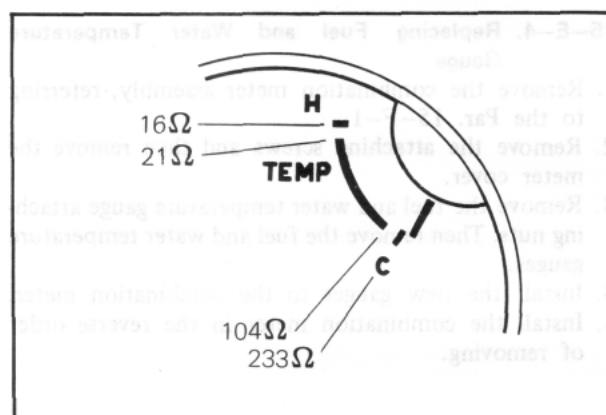

Fig. 15-20

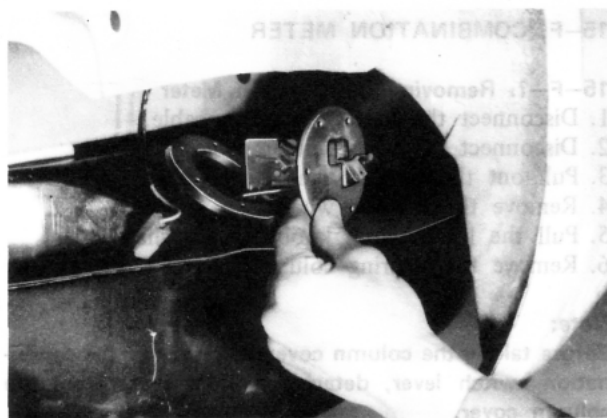

Fig. 15-21

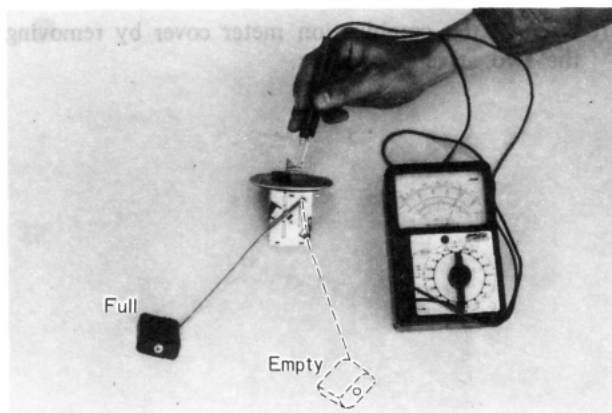

Fig. 15-22

4. Set the checker to specified resistance value as shown in figure.
5. Turn the ignition switch on and check whether the gauge needle point properly.
If the gauge needle points properly, the trouble is in the gauge unit while the trouble is in the meter, if the gauge indicates inaccurate.

Note:

- a) Wait for about 2 minutes before judgement.
- b) The tolerance is roughly ± 2 widths of needle.

15-E-2. Checking Water Temperature Gauge

1. Disconnect the connector from the water thermo unit.
2. Connect a \oplus probe of the checker (49 0839 285) to the connector and \ominus probe to earth connection.
3. Set the checker to specified resistance value and check the gauge in the same manner for the fuel gauge.

Note:

- a) Wait for about 2 minutes before judgement.
- b) The tolerance is roughly ± 2 widths of needle.

15-E-3. Checking Fuel Gauge Unit

1. Disconnect the battery negative cable.
2. Raise the rear end of the vehicle and support it with stands. Remove the rear left tire.
3. Remove the fuel tank cover.
4. Disconnect the connector from the gauge unit.
5. Remove the fuel gauge unit.

Note:

When the fuel gauge unit is removed, keep sparks, cigarettes and open flames away from the fuel tank.

6. Connect an ohmmeter to the fuel tank gauge unit terminals.
7. Slowly move the unit arm to Full or Empty positions until the unit arm contact with the stopper on the unit body.
If the reading is only slightly off from standard value, correct it by bending the unit arm.
The standard resistance is as follows.

Full position : $3 \begin{smallmatrix} +2 \\ -3 \end{smallmatrix} \Omega$

Empty position: $110 \begin{smallmatrix} +11 \\ -7 \end{smallmatrix} \Omega$

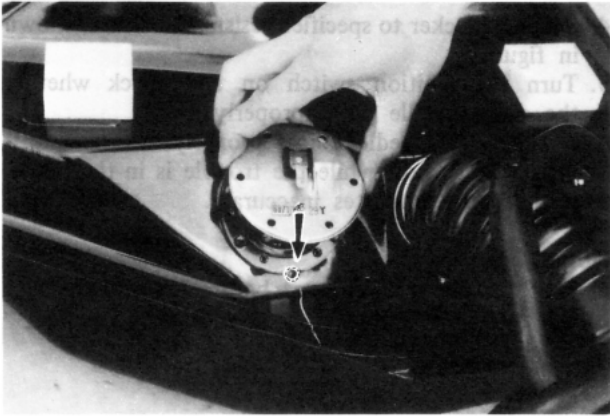

Fig. 15-23

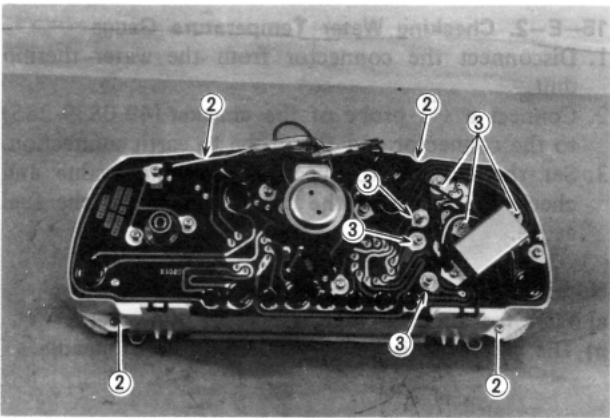

Fig. 15-24

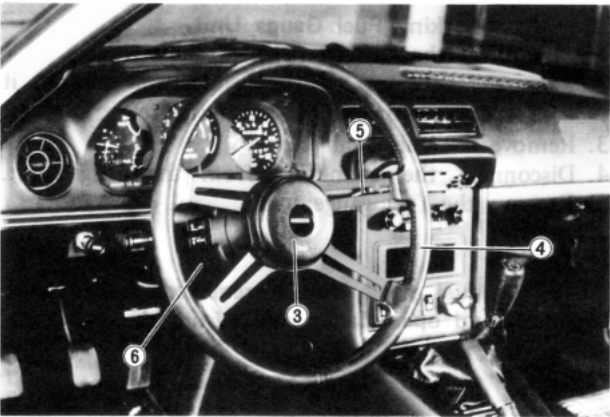

Fig. 15-25

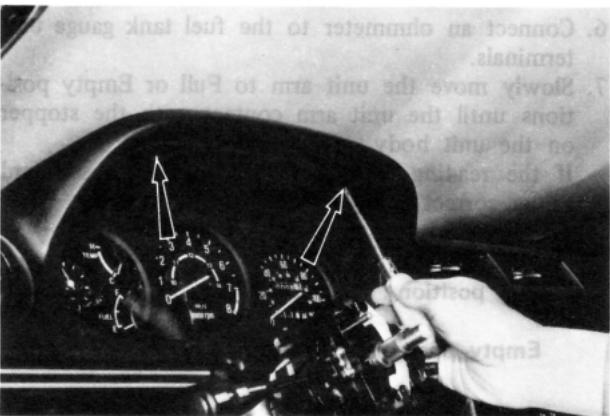

Fig. 15-26

6. Install the fuel gauge unit in the reverse order of removing.

Note:

When installing the fuel gauge unit, the gauge unit terminal directs to the rub on the fuel tank body as shown in figure.

15-E-4. Replacing Fuel and Water Temperature Gauge

1. Remove the combination meter assembly, referring to the Par. 15-F-1.
2. Remove the attaching screws and then remove the meter cover.
3. Remove the fuel and water temperature gauge attaching nuts. Then remove the fuel and water temperature gauges.
4. Install the new gauges to the combination meter.
5. Install the combination meter in the reverse order of removing.

15-F. COMBINATION METER

15-F-1. Removing Combination Meter

1. Disconnect the battery negative cable.
2. Disconnect the speedometer cable.
3. Pull out the steering wheel center cap.
4. Remove the steering wheel.
5. Pull the light switch knob off the shaft.
6. Remove the steering column cover.

Note:

Before taking the column cover (left) out of the combination switch lever, detach the hole cover from the column cover.

7. Remove the combination meter cover by removing the two attaching screws.

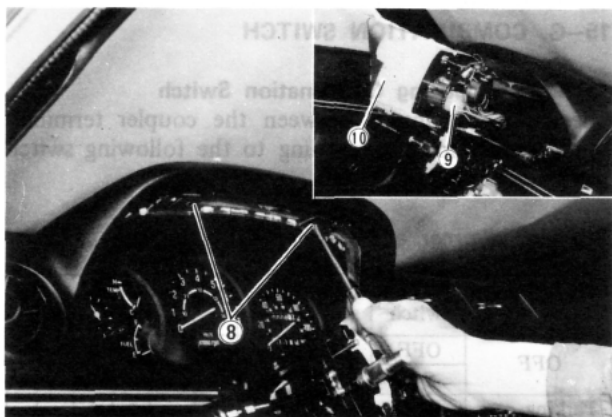

Fig. 15-27

8. Remove the combination meter assembly attaching screws.
9. Draw out the combination meter assembly, and disconnect the multiple connectors.
10. Take out the combination meter assembly.

15-F-2. Checking Combination Meter

1. Visually inspect the print panel for any damage and rust.
2. Check the continuity between the connector pin and indicator light, and that between connector pin and gauge using an ohmmeter.

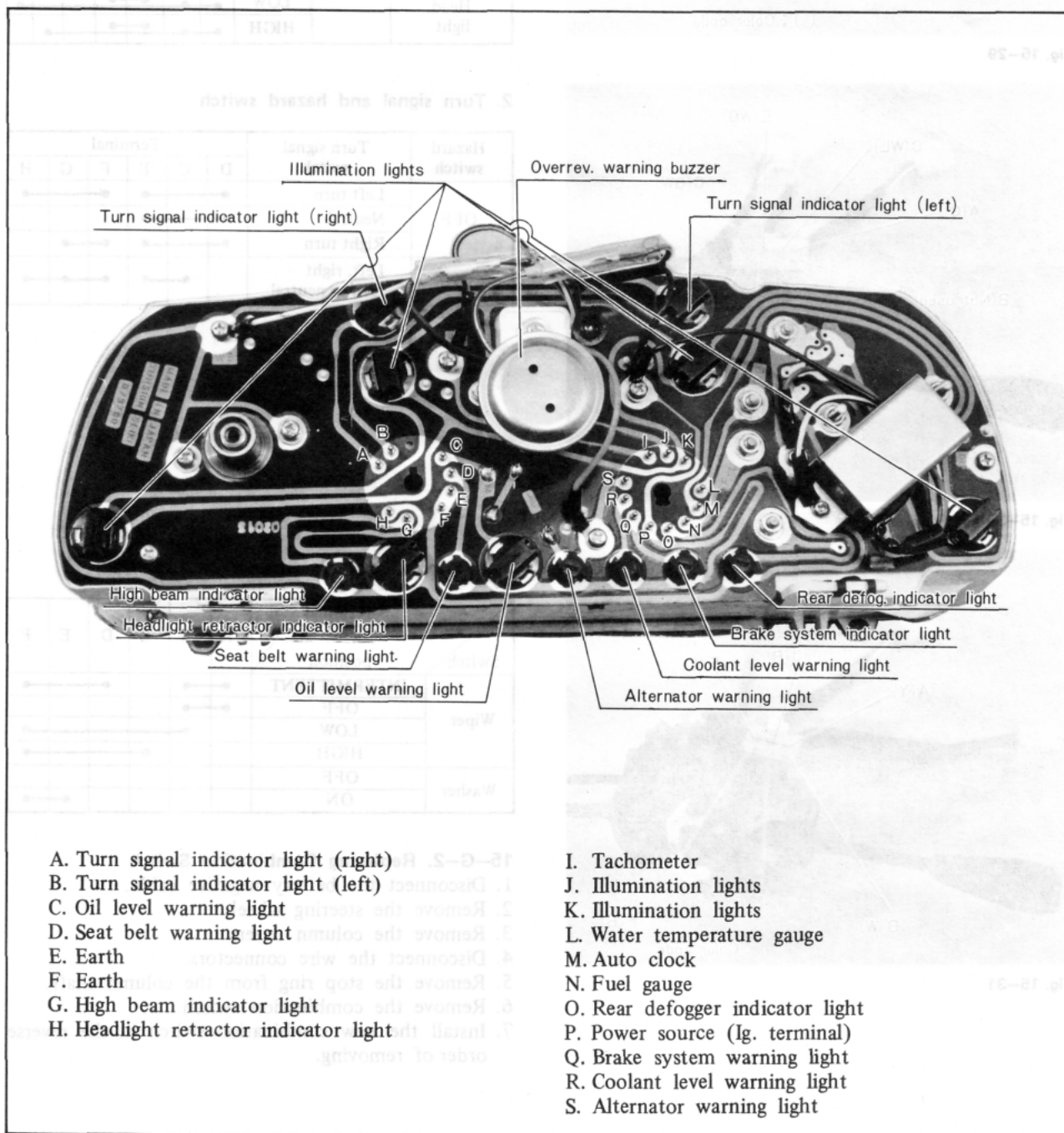

Fig. 15-28

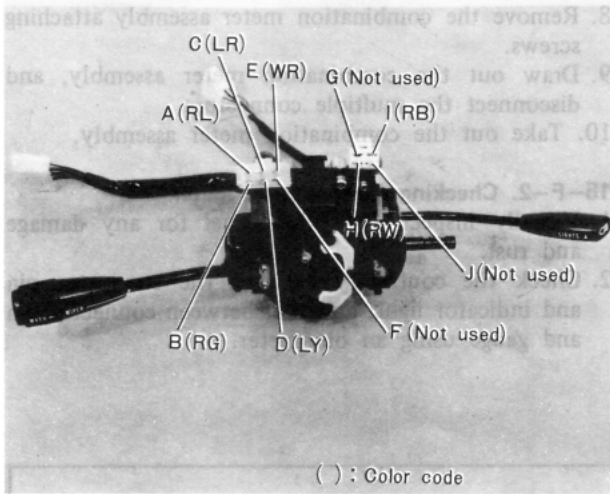

Fig. 15-29

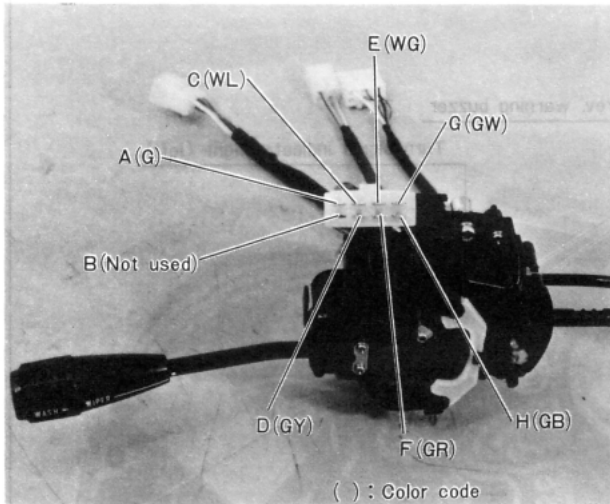

Fig. 15-30

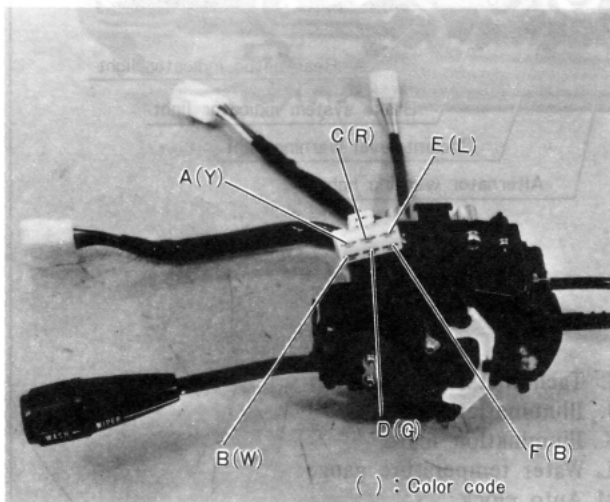

Fig. 15-31

15-G. COMBINATION SWITCH

15-G-1. Checking Combination Switch

Check the continuity between the coupler terminals using an ohmmeter according to the following switch interconnection diagram.

1. Light, dimmer and passing switch

Light switch	Passing switch	Dimmer switch	Terminal							
			E	C	A	B	D	H	I	
OFF	OFF				●	●	●			
	ON		●		●	●	●			
Parking, Marker lights	OFF		●		●	●	●			
	ON		●		●	●	●			
Head light		LOW	●		●	●	●			
		HIGH	●		●	●	●			

2. Turn signal and hazard switch

Hazard switch	Turn signal switch	Terminal					
		D	C	E	F	G	H
OFF	Left turn	●		●		●	●
	Neutral	●		●		●	●
	Right turn	●		●		●	●
ON	Left, right turn or neutral		●			●	●

3. Wiper and washer switch

Switch	Terminal Switch position	Terminal					
		A	B	C	D	E	F
Wiper	INTERMITTENT	●	●			●	●
	OFF	●	●				
	LOW		●	●	●	●	●
Washer	HIGH			●	●	●	●
	OFF						
Washer	ON						●
	ON						●

15-G-2. Replacing Combination Switch

1. Disconnect the battery negative cable.
2. Remove the steering wheel.
3. Remove the column covers.
4. Disconnect the wire connectors.
5. Remove the stop ring from the column shaft.
6. Remove the combination switch.
7. Install the new combination switch in the reverse order of removing.

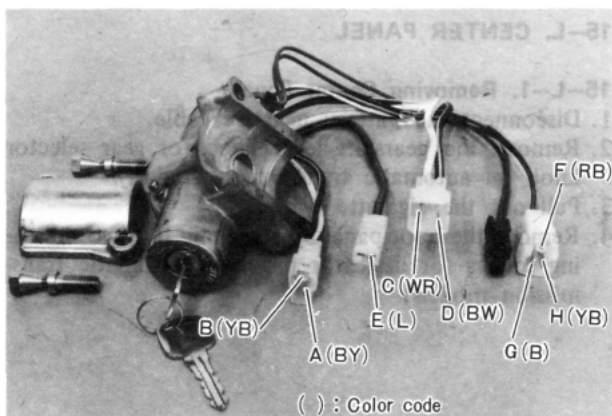

Fig. 15-32

15-H. IGNITION SWITCH & STEERING LOCK

Check the continuity between the coupler terminals using an ohmmeter according to the following switch interconnection diagram.

Terminal	C	D	A	E	B	F	H	G
Key position								
ACC	●	—	●					
ON	●	—	●	—	●		●	—
START	●	—	●	—	●	—	●	—

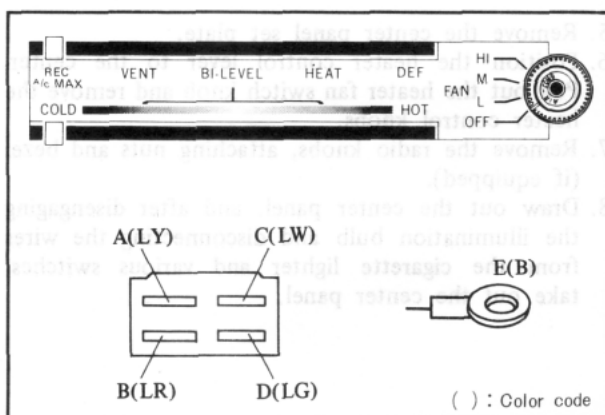

Fig. 15-33

15-I. HEATER FAN SWITCH INSPECTION

Check the continuity between the coupler terminals using an ohmmeter according to the following switch interconnection diagram.

Terminal	A	B	C	E
Switch position				
High	●	—	●	—
Medium		●	—	●
Low			●	—

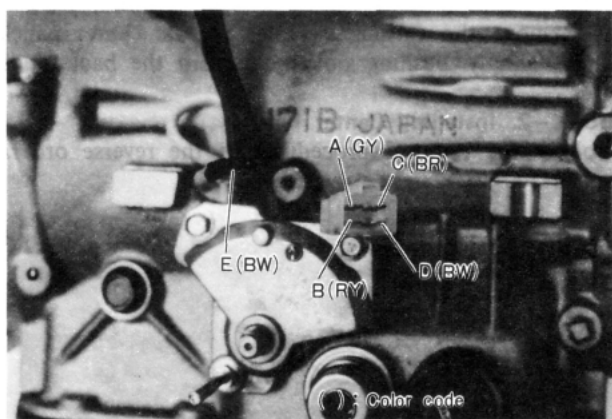

Fig. 15-34

15-J. INHIBITOR SWITCH INSPECTION

Check the continuity between the coupler terminals using an ohmmeter according to the following switch interconnection diagram.

Terminal	A	B	C	E
Switch position				
P			●	—
R	●	—		
N			●	—

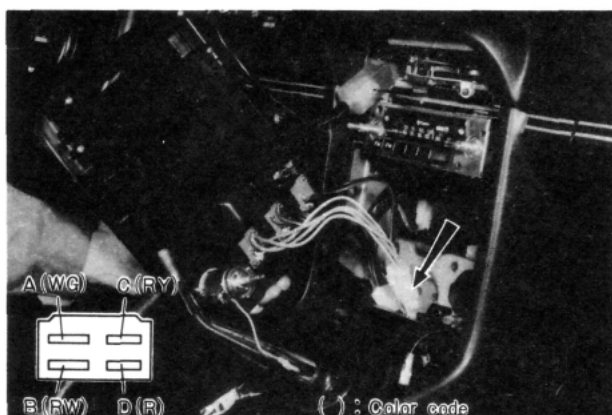

Fig. 15-35

15-K. RETRACTABLE HEADLIGHT SWITCH INSPECTION

Check the continuity between the coupler terminals using an ohmmeter according to the following switch interconnection diagram.

Terminal	A	B	C	D
Switch position				
ON	●	—	●	—
OFF		●	—	●

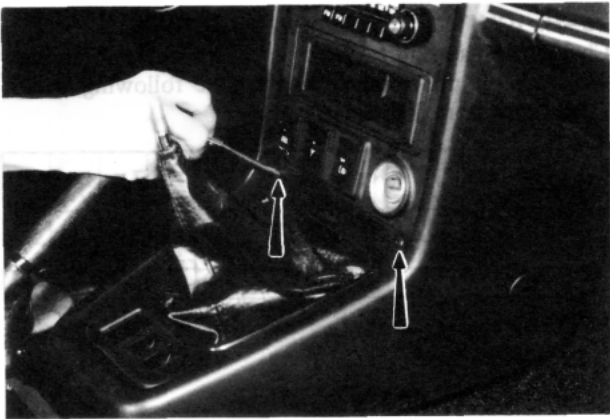

Fig. 15-36



Fig. 15-37



Fig. 15-38

15-L. CENTER PANEL

15-L-1. Removing Center Panel

1. Disconnect the battery negative cable.
2. Remove the gearshift lever knob (or gear selector knob on automatic transmission models).
3. Pull out the cigarette lighter.
4. Remove the boot panel by removing the two attaching screws (or indicator panel on automatic transmission models).

5. Remove the center panel set plate.
6. Position the heater control lever to the center. Pull out the heater fan switch knob and remove the heater control knobs.
7. Remove the radio knobs, attaching nuts and bezel (if equipped).
8. Draw out the center panel, and after disengaging the illumination bulb and disconnecting the wires from the cigarette lighter and various switches, take out the center panel.

9. Remove the various switches on the center panel by simply pushing out them from the back side.

15-L-2. Installing Center Panel

Follow the removal procedures in the reverse order.

15-K. RETRACTABLE HEADLIGHT SWITCH
INSPECTION
Check the continuity between the couple terminals using an ohmmeter according to the following switch interconnection diagram.

Terminal	A	B	C	D
Switch position				
ON	—	—		
OFF		—		