

Mazda RX-7

1980

REPAIR MANUAL

AIR CONDITIONING
COMPRESSOR
6P134

mazda

FOREWORD

This manual has been published to explain how to repair the swash plate type compressor (6P134) developed for medium vehicle.

When repairing the compressor, repairing should be carried out as described in this manual.

Please study this manual before repairing.

We reserve the right to make changes in this manual, at any time, without notice.

TABLE OF CONTENTS

TROUBLESHOOTING	1
SPECIAL SERVICE TOOLS	2
DISASSEMBLY OF MAGNETIC CLUTCH	3
DISASSEMBLY OF COMPRESSOR	8
INSPECTION OF COMPRESSOR	15
ASSEMBLY OF COMPRESSOR	16
PERFORMANCE TEST OF COMPRESSOR	21
FINISH	23

TROUBLE SHOOTING

SYMPTOM	POSSIBLE CAUSES	REMEDY
1. Noise from compressor	1. Defective gasket	Replace
2. Noise from magnetic clutch	1. Defective bearing 2. Defective clutch face	Replace Replace
3. Insufficient cooling	1. Defective gasket 2. Defective reed valve	Replace Replace
4. Not rotating	1. Locked by item 3-2. 2. Seized magnetic clutch 3. Rotating parts seized by insufficient oil amount	Replace Replace or repair Replace or repair
5. Oil and/or gas leakage	1. Defective seal 2. Defective "O" ring	Replace Replace

SPECIAL SERVICE TOOLS

For MAGNETIC CLUTCH

No.1 : Pressure plate
remover

No.2 : Pressure plate
holding bar

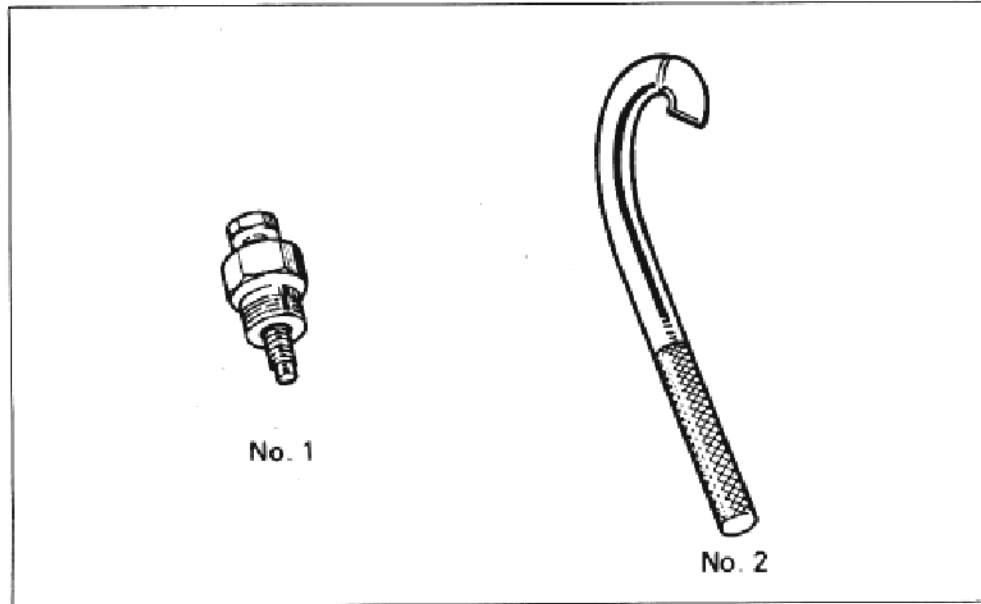

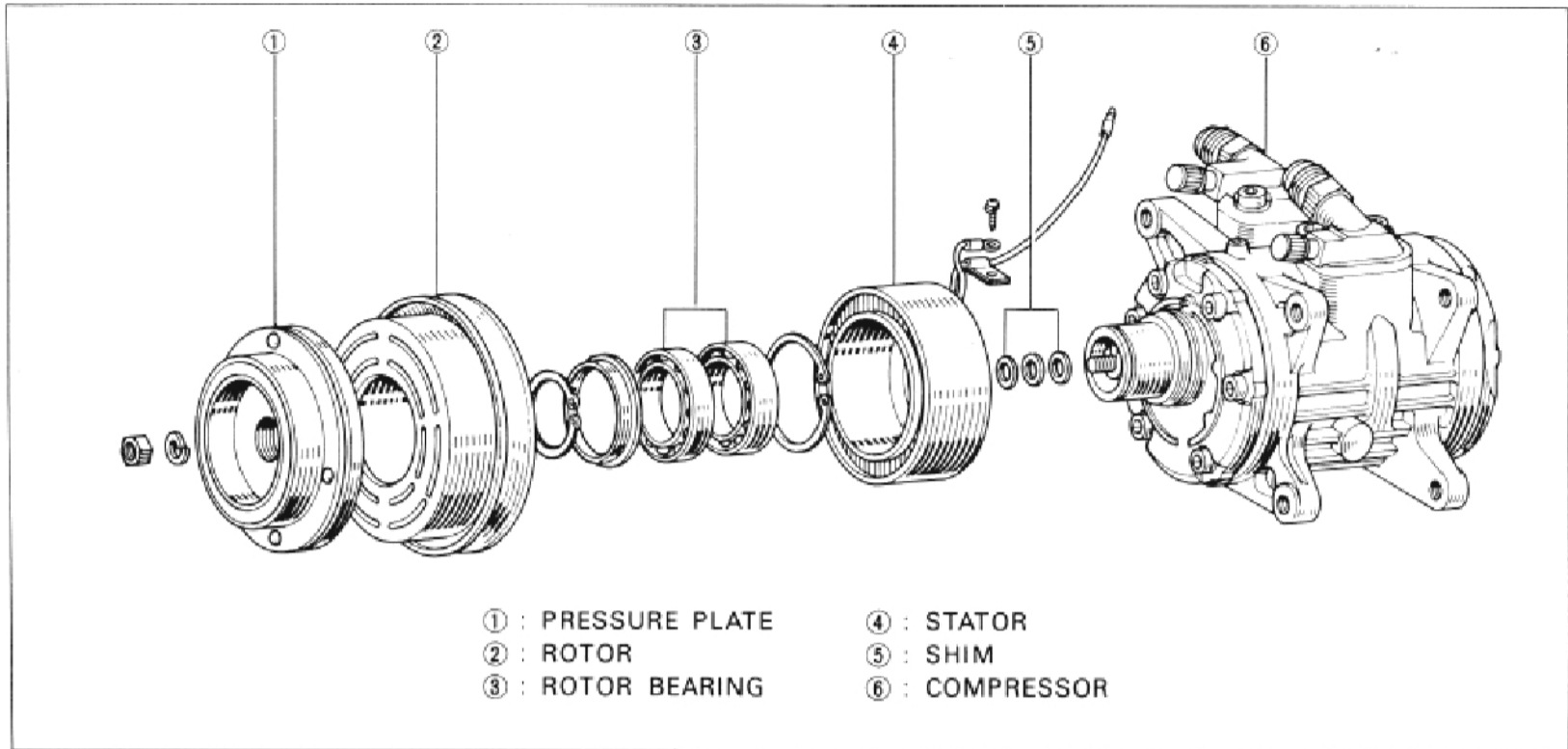

DISASSEMBLY OF MAGNETIC CLUTCH

1. REMOVE PRESSURE PLATE

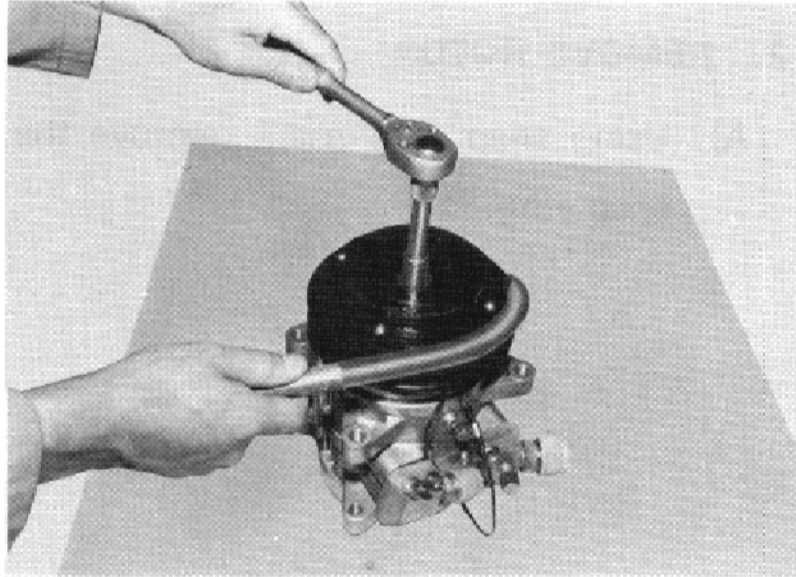

- A) Using a pressure plate holding bar (SST) and a 12 mm socket, remove the shaft nut.

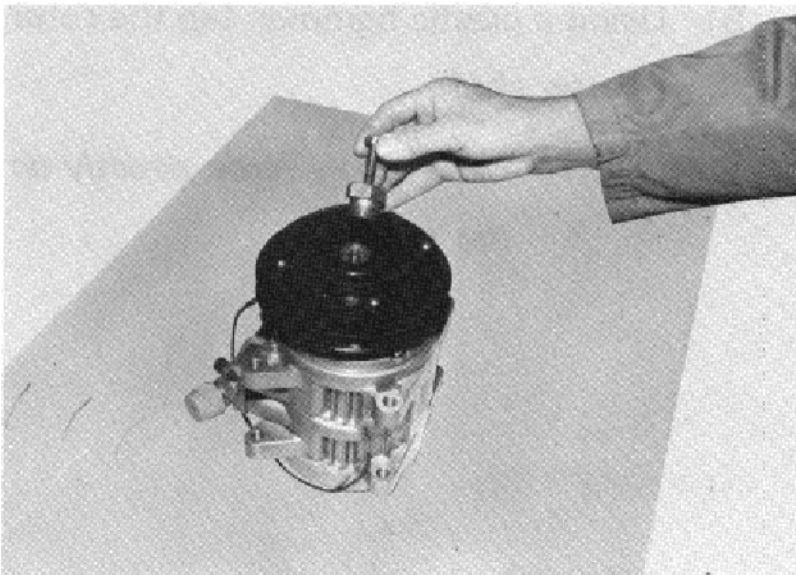

- B) Install a pressure plate remover (SST) to the pressure plate.

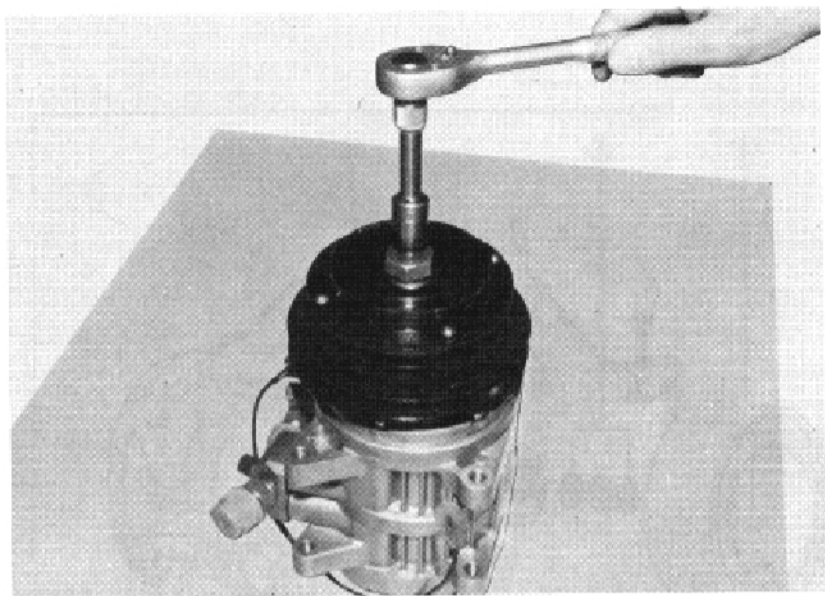

- C) Using a pressure plate remover (SST) and socket, remove the pressure plate.

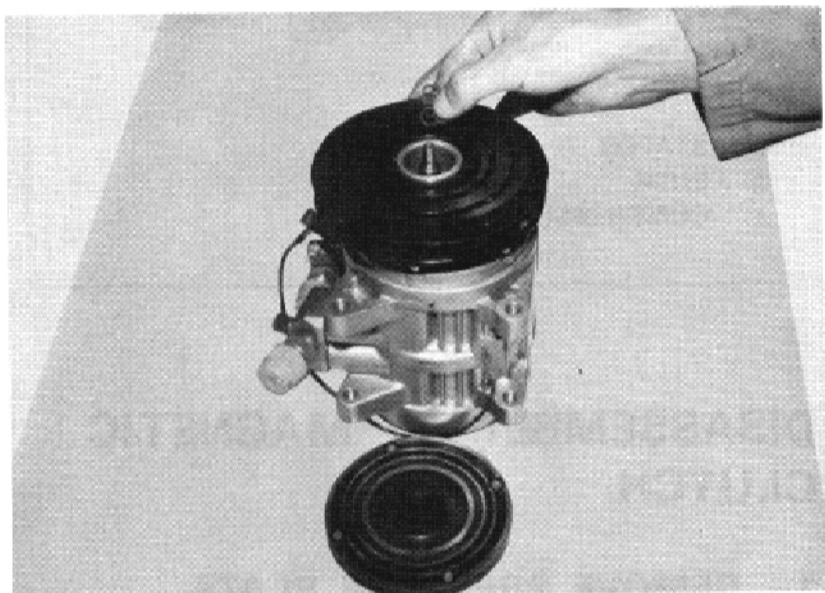

- D) Remove the shims from the shaft.

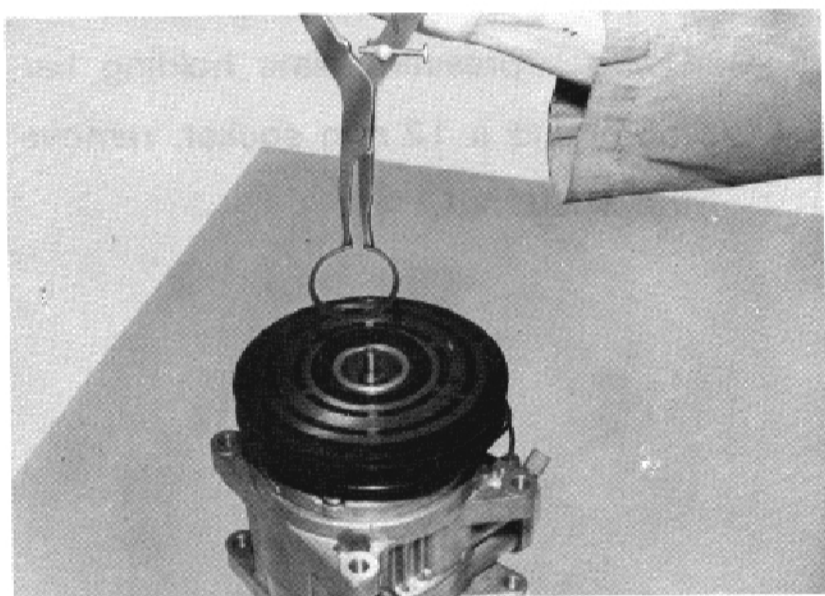

2. REMOVE ROTOR

- A) Using snap ring pliers, remove the snap ring.

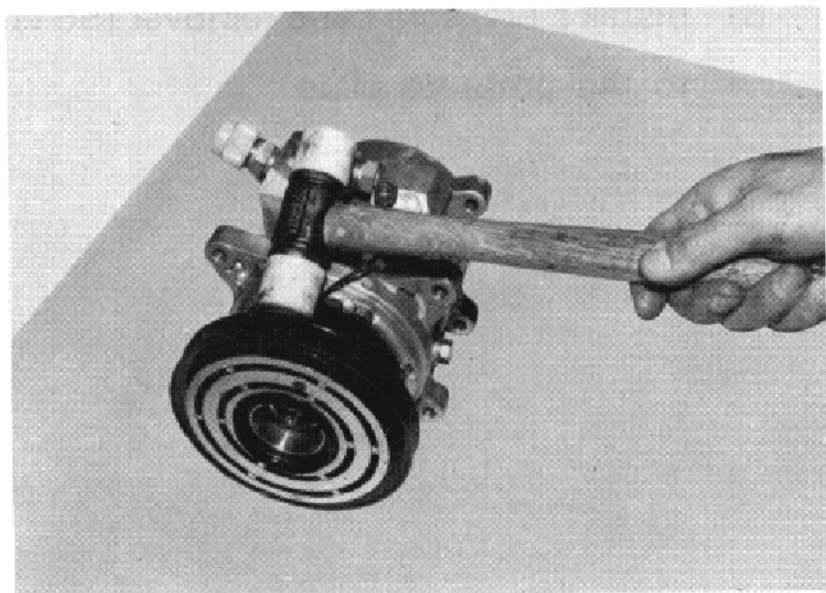

- B) Using a plastic hammer, tap the rotor off the shaft.

CAUTION: *Never apply force directly on the shaft.*

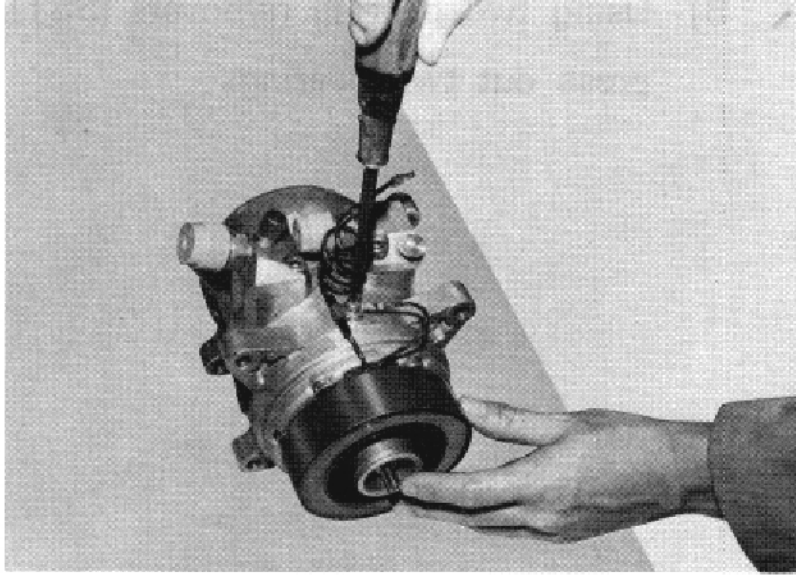

3. REMOVE STATOR

A) Disconnect the stator lead wires from the compressor housing.

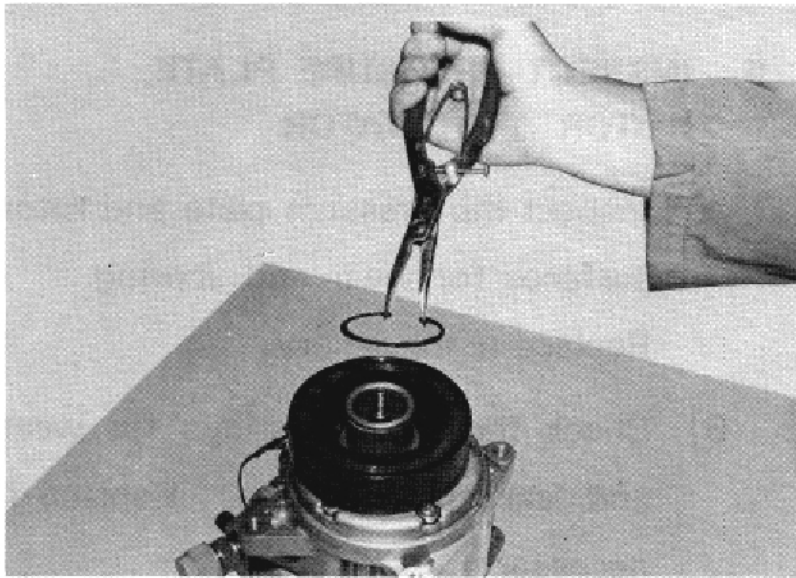

B) Using snap ring pliers, remove the snap ring.

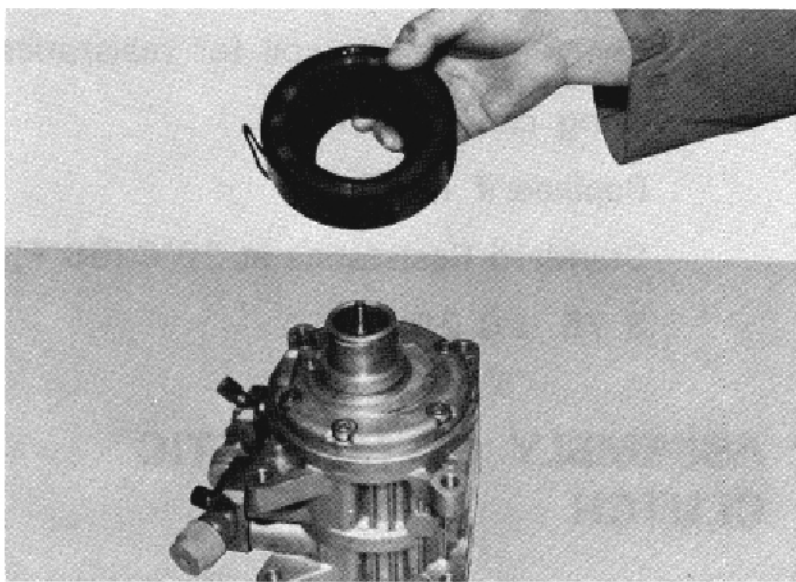

C) Remove the stator.

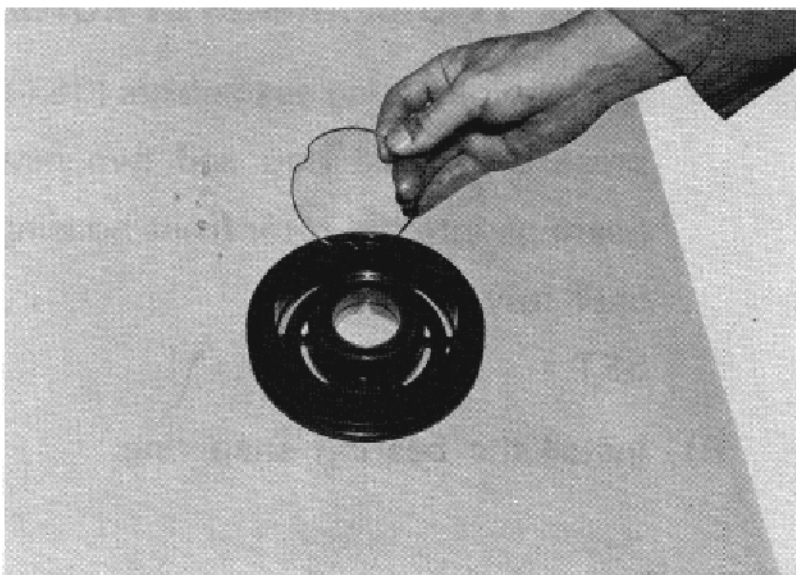

4. REMOVE ROTOR BEARINGS

NOTE: Press the bearing out only if they are to be replaced.

A) Remove the bearing snap ring from the rotor.

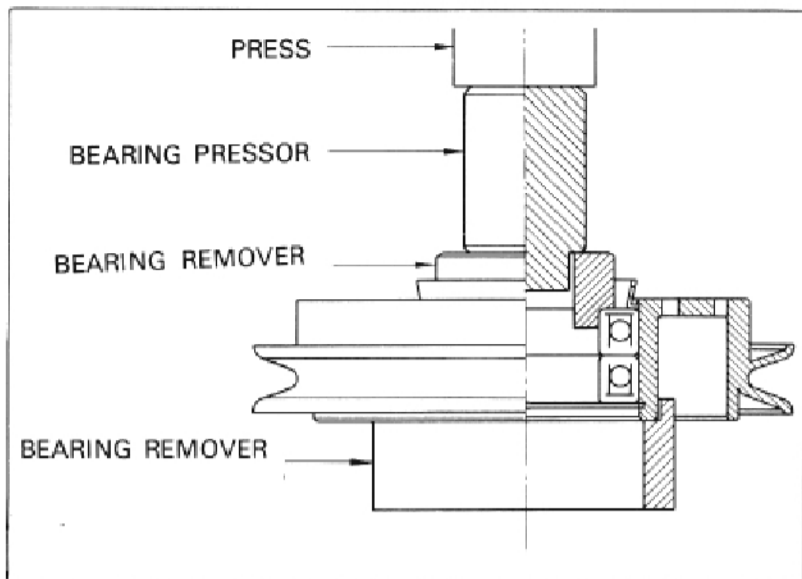

- B) Using two bearing removers (SST), press out two bearings.

5. INSPECT PRESSURE PLATE, ROTOR AND STATOR

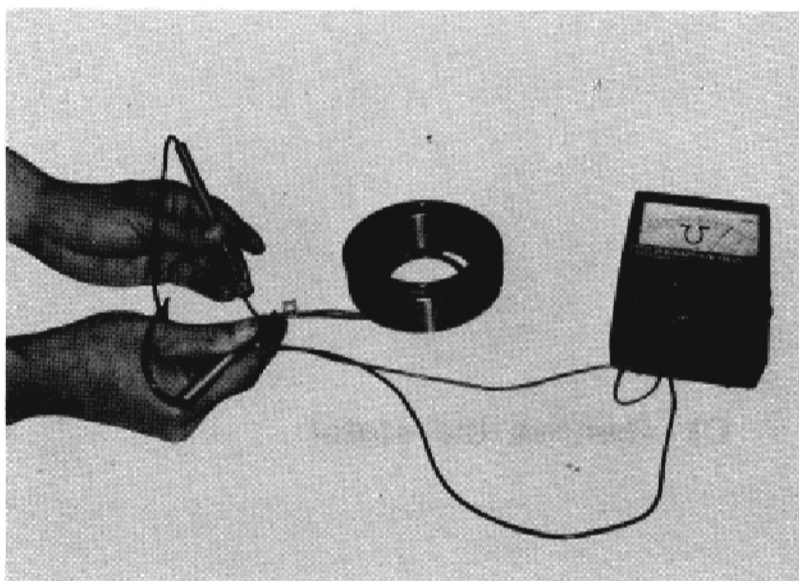

- A) Inspect the pressure plate and rotor surfaces for wear and scoring. Replace if necessary.
- B) Check the rotor bearings for wear and leakage of grease. Replace if necessary.
- C) Check the stator coil for resistance using circuit tester. Replace if necessary.
- Standard Resistance at 20°C (68°F):
 $3.75 \pm 0.2\Omega$

ASSEMBLY OF MAGNETIC CLUTCH

1. INSTALL TWO BEARINGS IN ROTOR

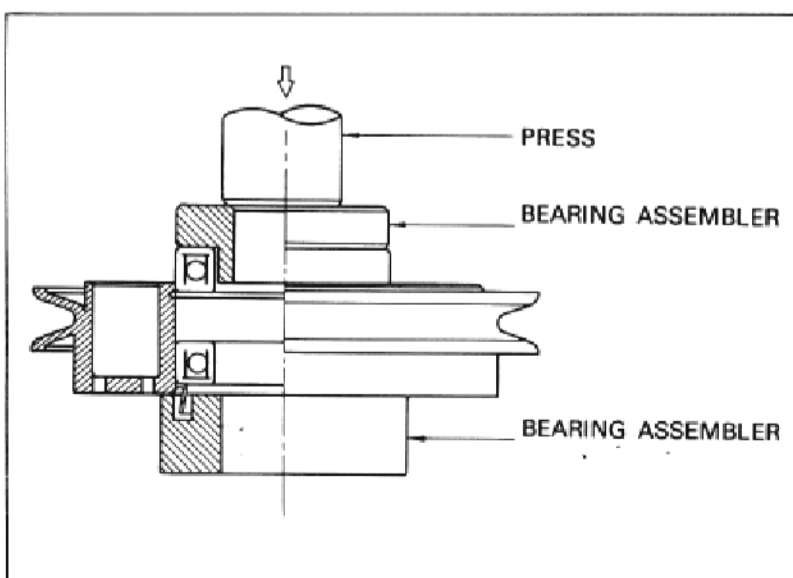

- A) Using two bearing assemblers (SST), press the shield ring and two new bearings into the rotor front housing until fully seated.
- SST
- B) Install the bearing snap ring.

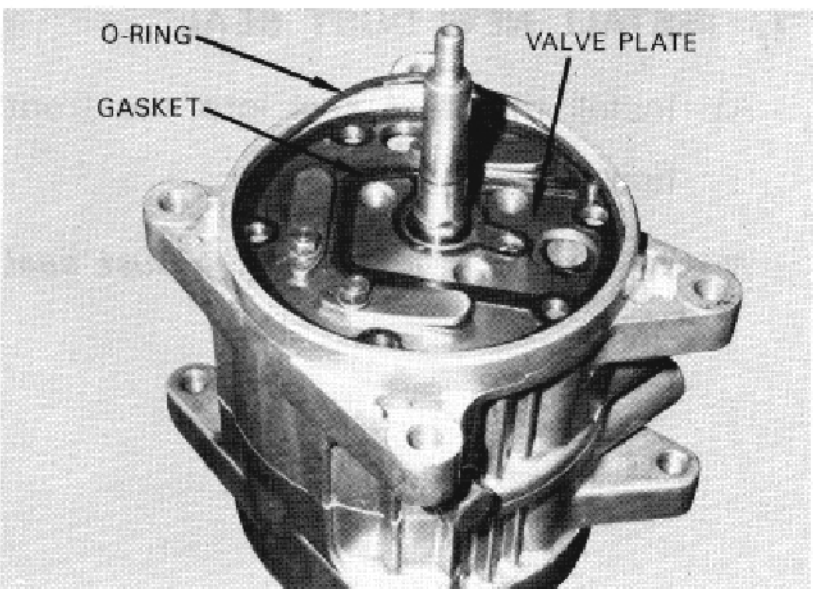
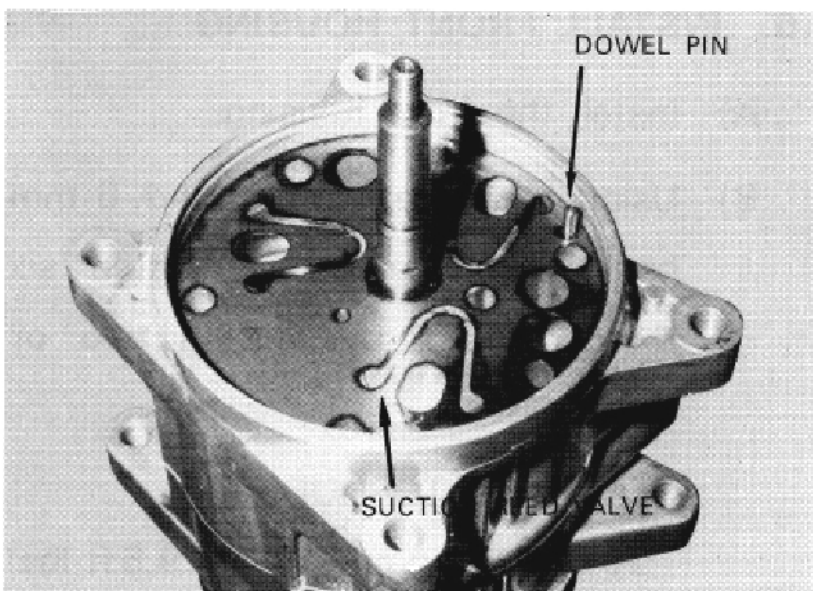
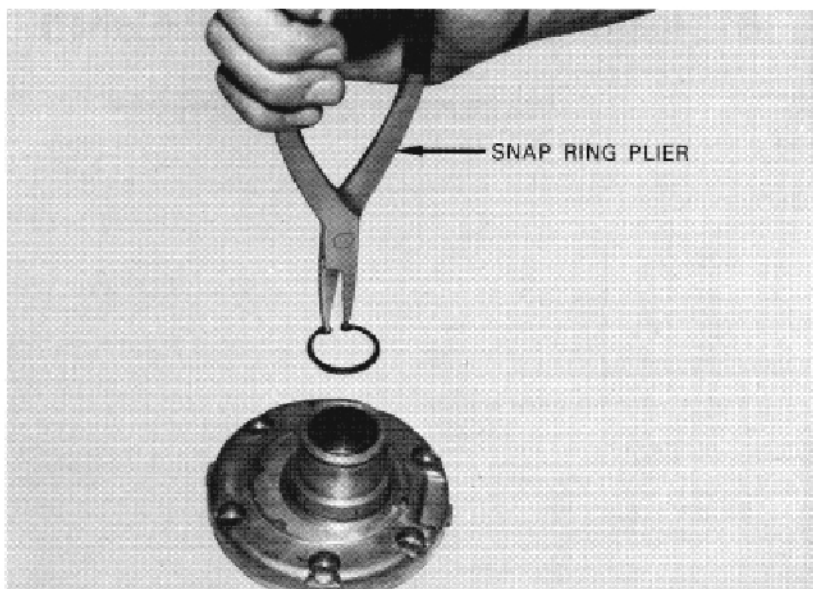
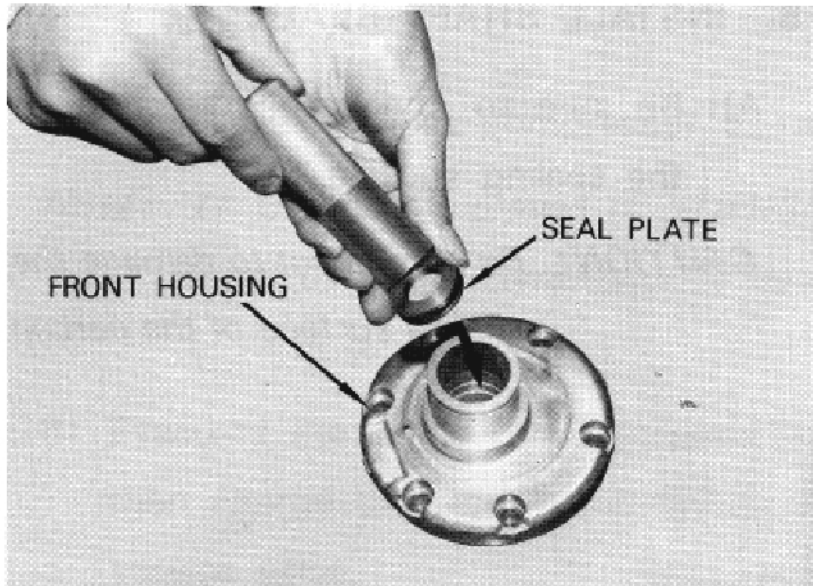

3. INSTALL SEAL PLATE

- A) Put the seal plate into the front housing.
- B) Using the seal plate pressor (SST), press the seal plate until fully seated.
- C) Using the snap ring pliers, install the snap ring.

4. INSTALL FRONT VALVE PLATE

- A) Install the dowel pin and suction reed valve.
- B) Install the front valve plate.
- C) Install new gasket and O-ring.

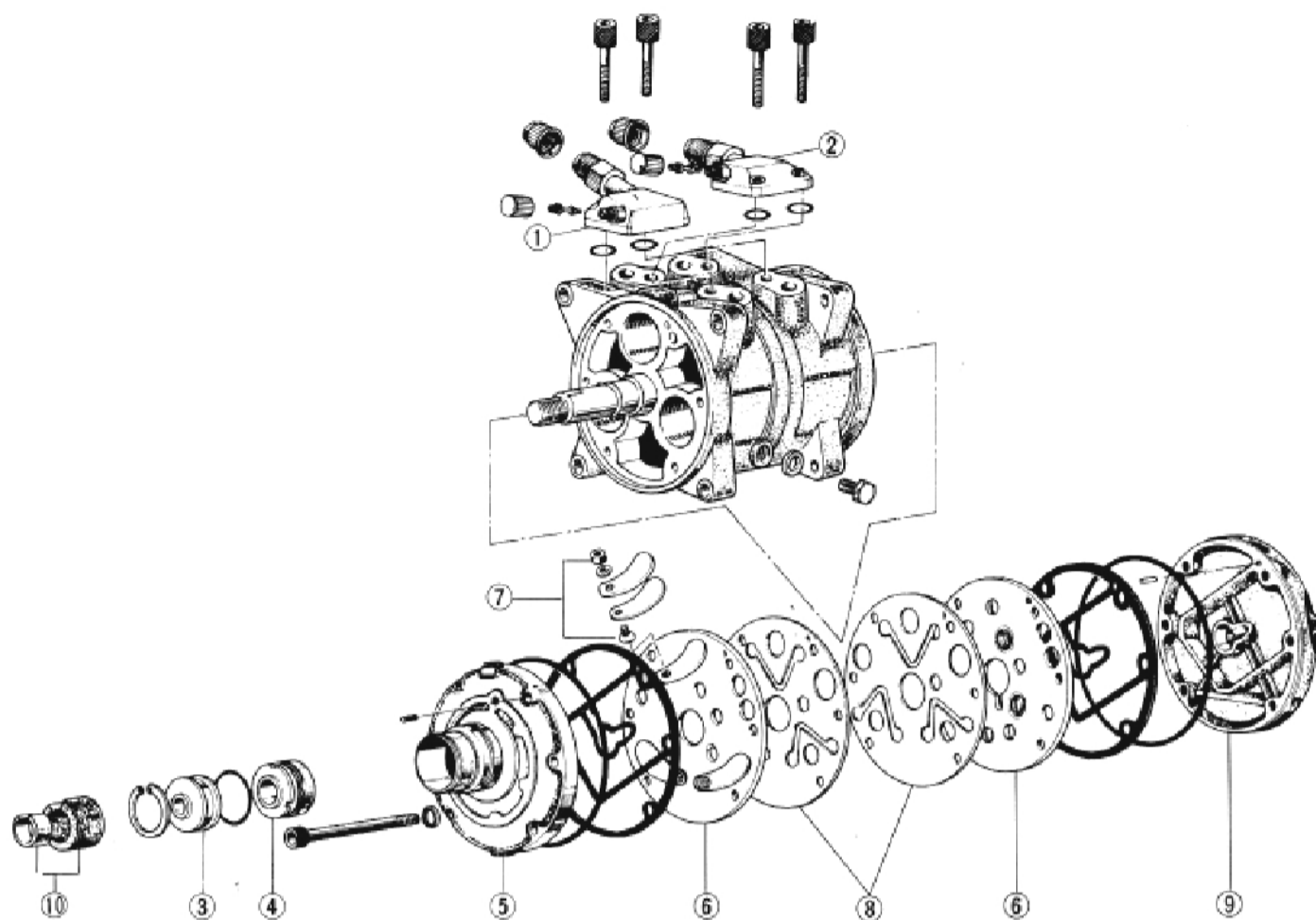

- | | |
|-----------------------------|--------------------------|
| ① : DISCHARGE SERVICE VALVE | ⑥ : VALVE PLATE |
| ② : SUCTION SERVICE VALVE | ⑦ : DISCHARGE REED VALVE |
| ③ : SEAL PLATE | ⑧ : SUCTION REED VALVE |
| ④ : SHAFT SEAL | ⑨ : REAR HOUSING |
| ⑤ : FRONT HOUSING | ⑩ : DUST SEAL |

NOTE: *The compressor should be removed from the vehicle for repairing. Before disassembling, it is recommended that the compressor body be flushed with a clean, suitable solvent. The compressor should be free of all foreign material internally.*

DISASSEMBLY OF COMPRESSOR

1. REMOVE DUST SEAL

Using a screwdriver, pry out the dust seal.

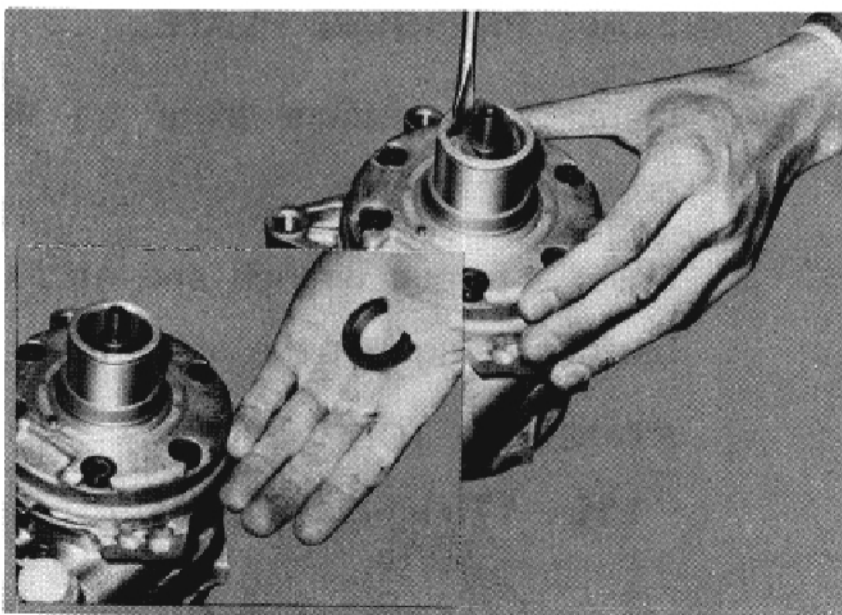

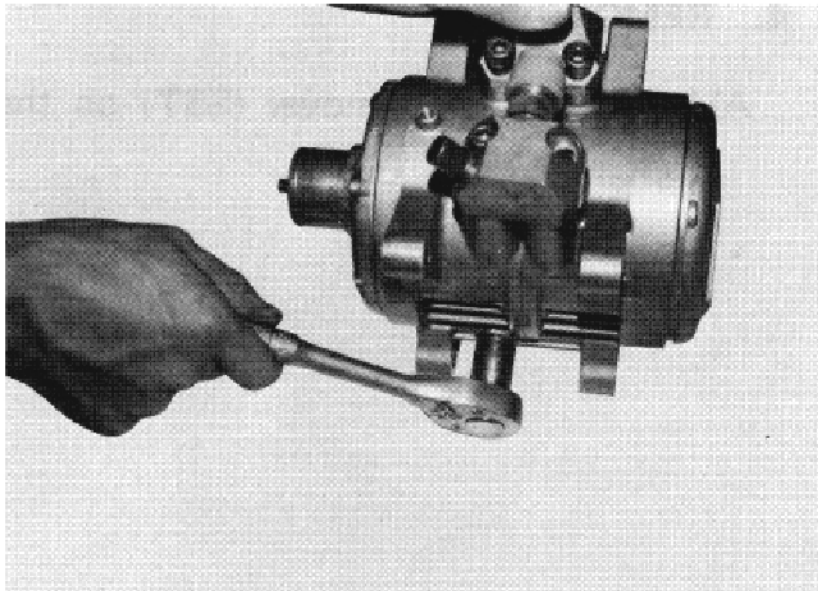

2. DRAIN COMPRESSOR OIL

A) Remove the oil plug.

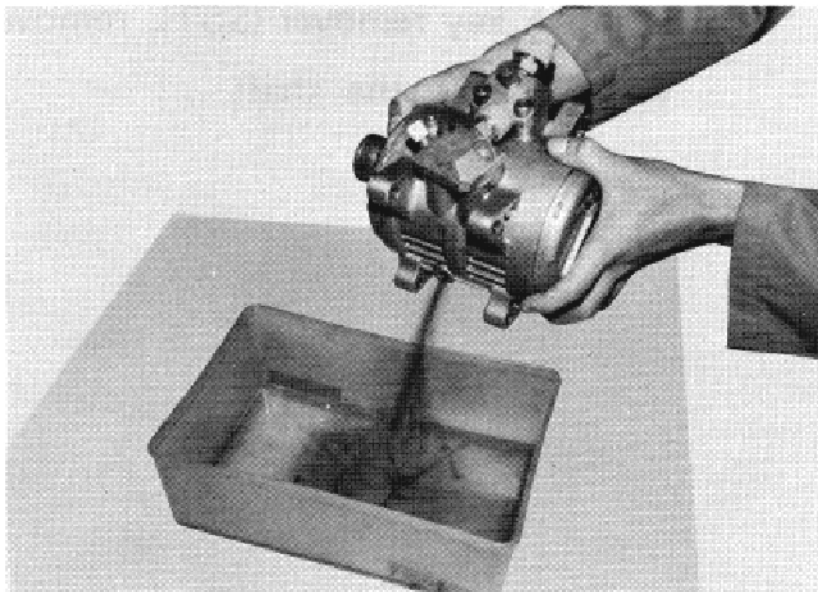

B) Drain compressor oil.

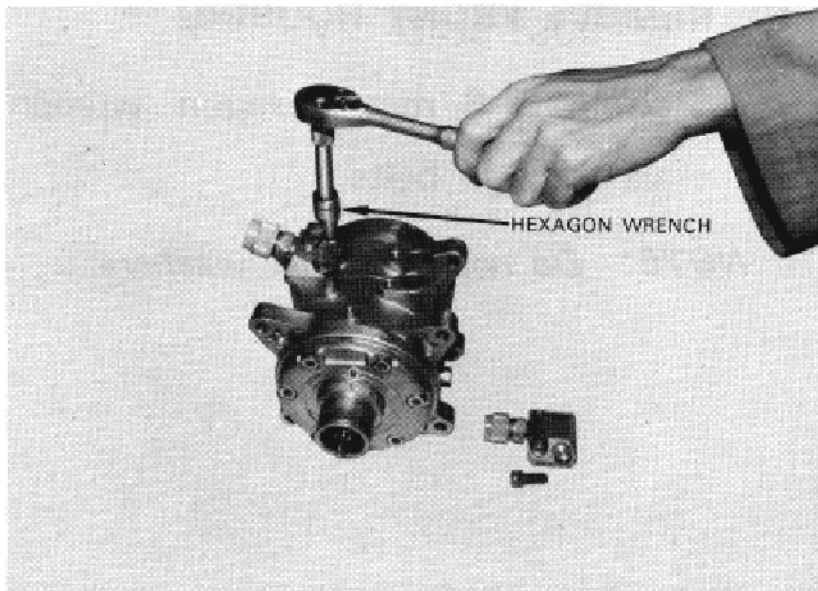

3. REMOVE TWO SERVICE VALVES

A) Using a hexagon wrench, remove bolts holding two service valves.

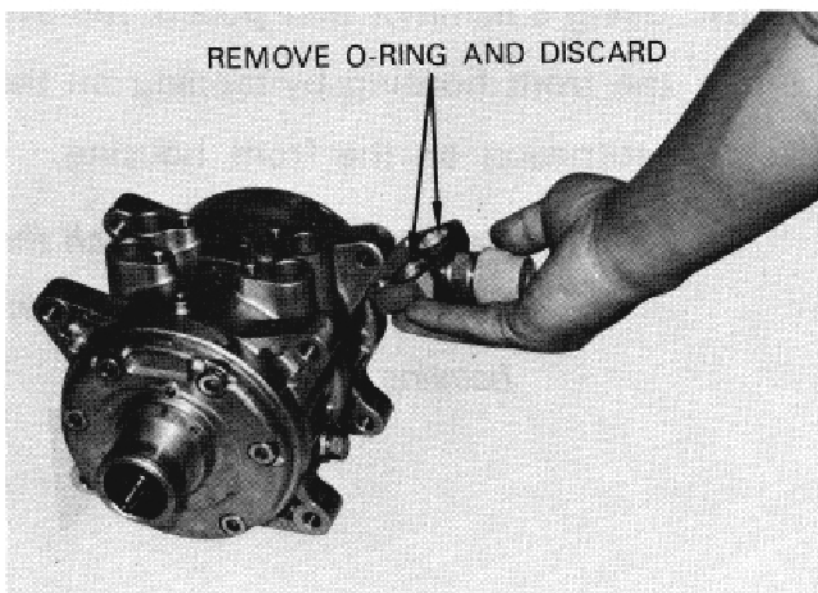

B) Remove the O-rings from the service valves and discard them.

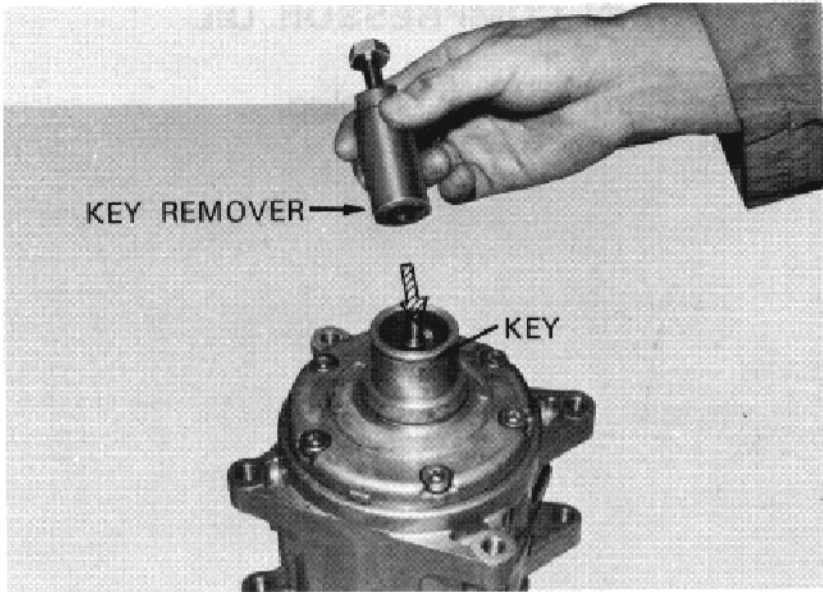

4. REMOVE KEY

A) Install a key remover (SST) on the shaft.

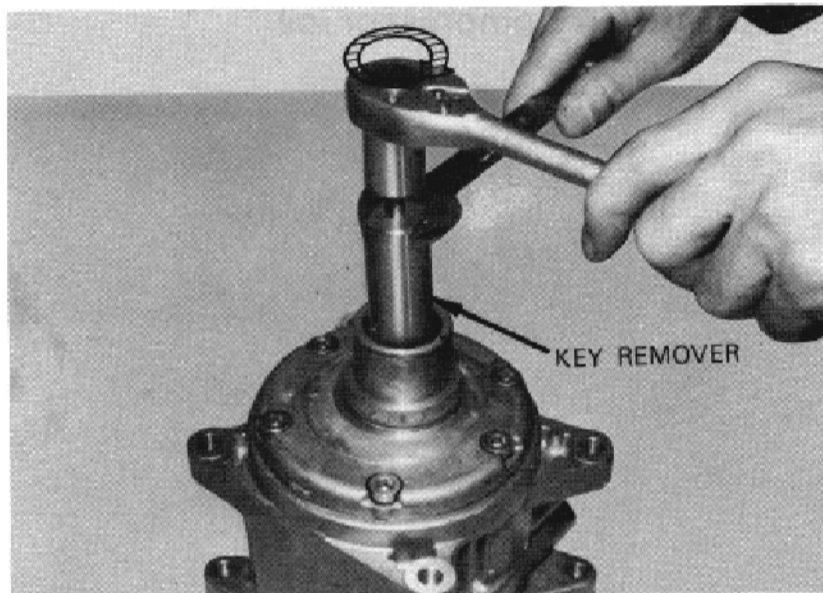

B) Using a key remover (SST), remove the key from the shaft.

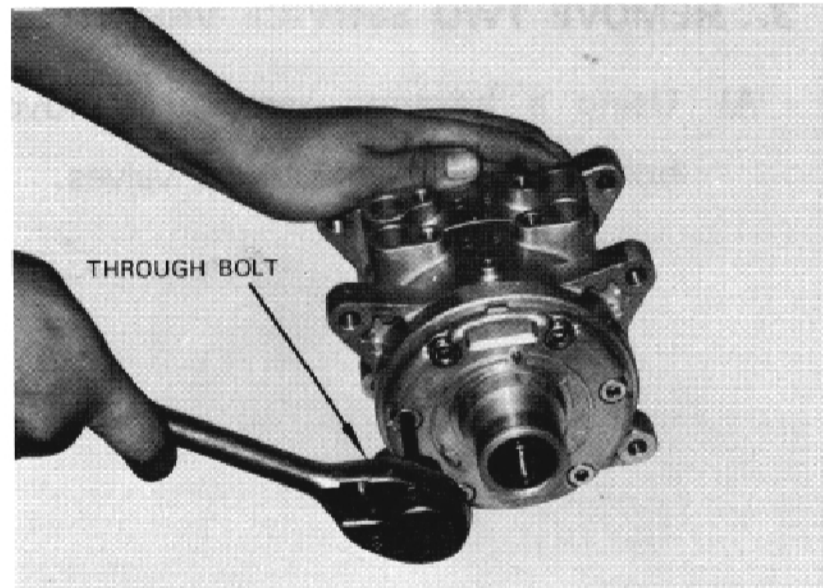

5. REMOVE FRONT HOUSING

A) Using a 6 mm hexagon wrench, six through bolts.

NOTE: Do not reuse six washers.

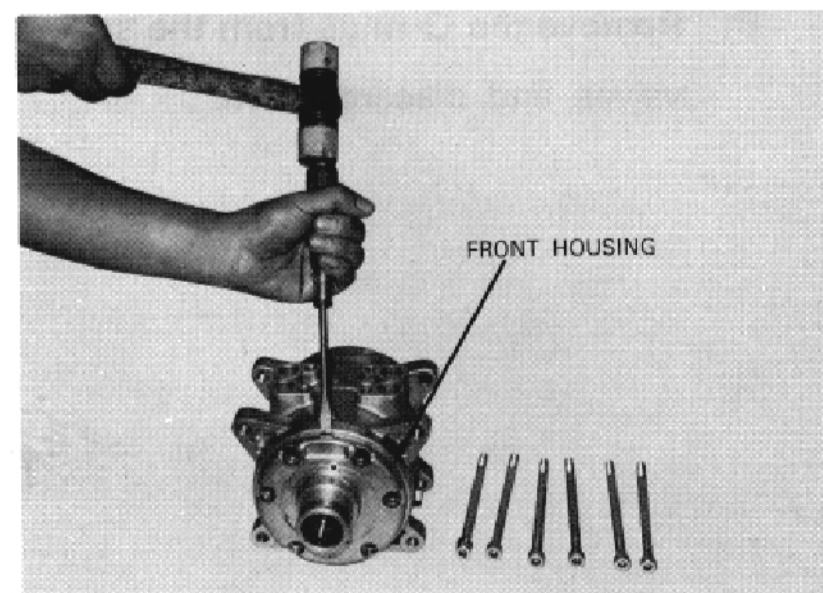

B) Using a hammer and punch, remove the front housing by tapping on the protrusion on the front housing.

CAUTION: Be careful not to scratch the sealing surface of the front housing.

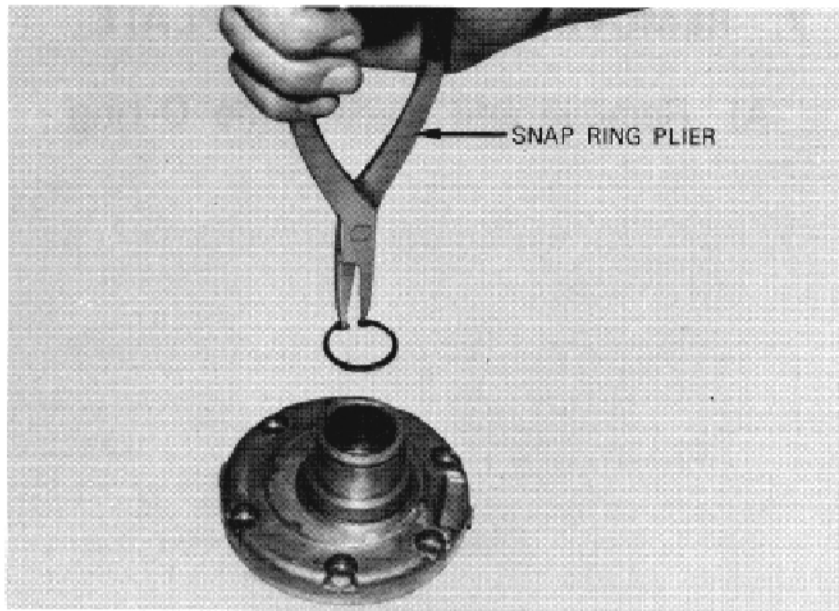

6. SEAL PLATE AND SHAFT SEAL

A) Using a snap ring pliers, remove the snap ring.

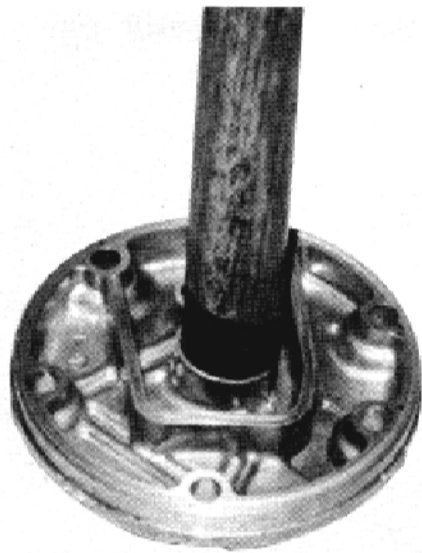

B) Push the seal plate out from the front housing.

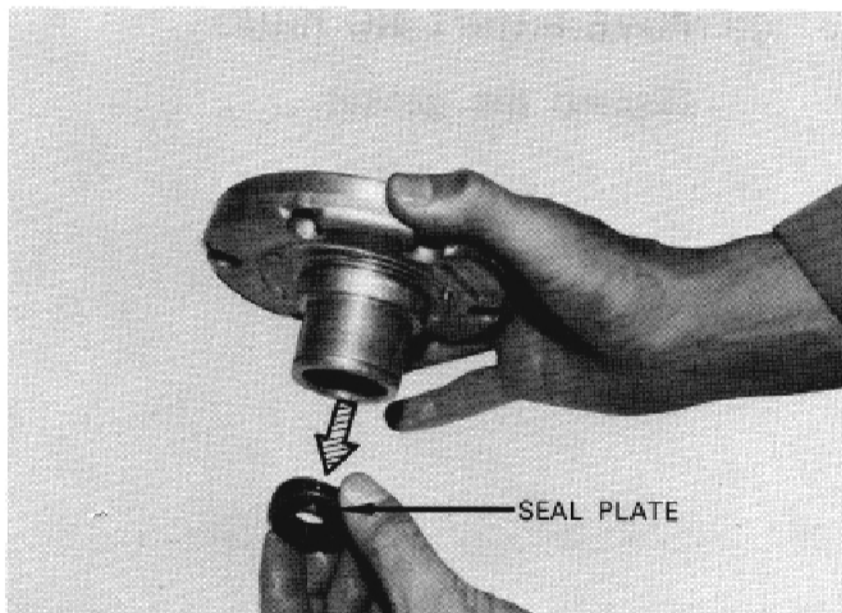

Note: 1) Remove the seal plate if necessary.

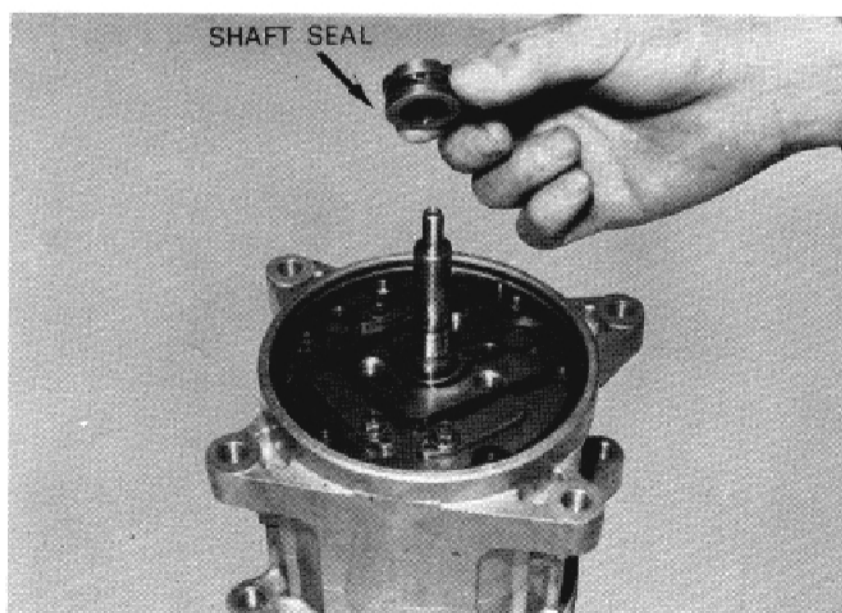

C) Remove the shaft seal from the compressor shaft.

Note: 1) Be sure to handle the shaft seal carefully not to scratch the carbon seal.

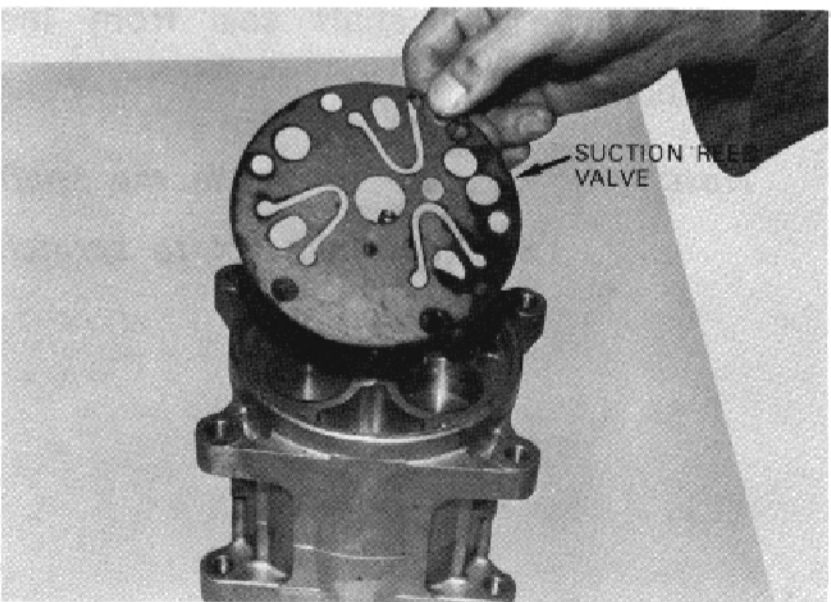
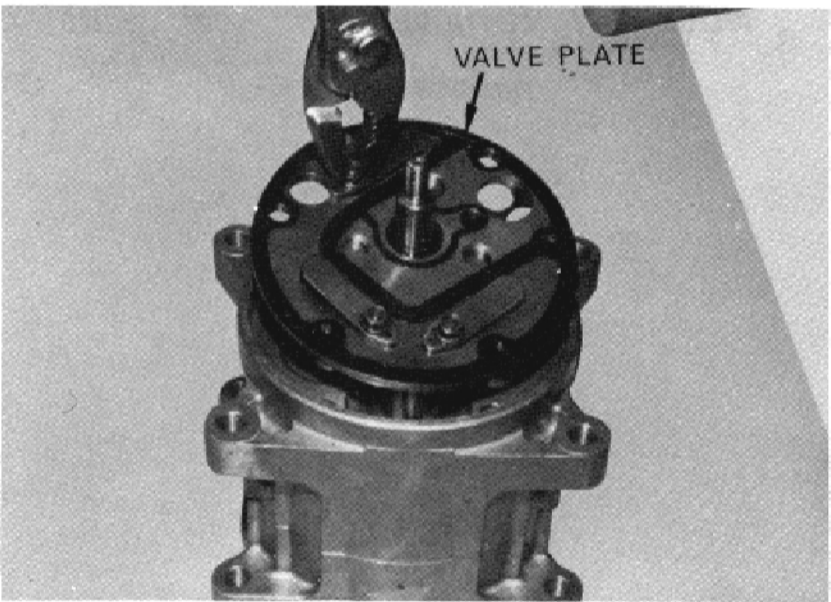
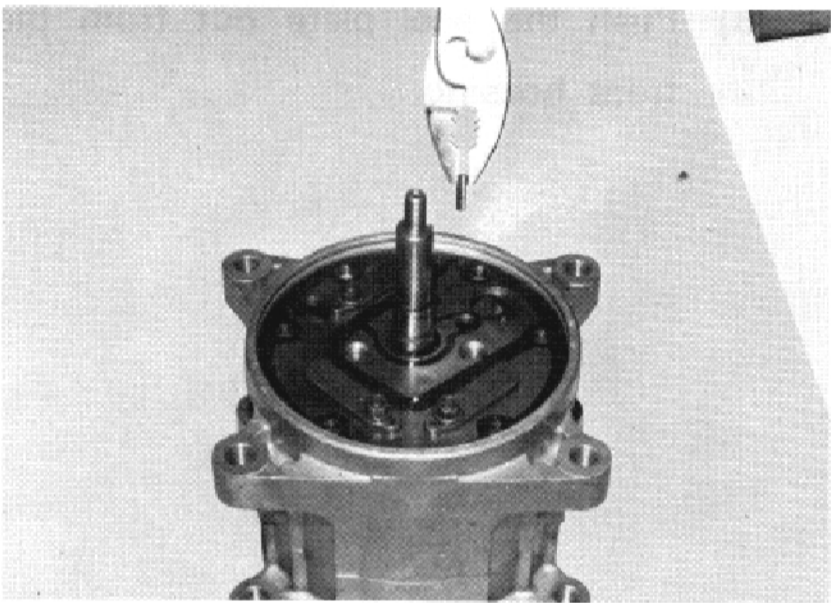
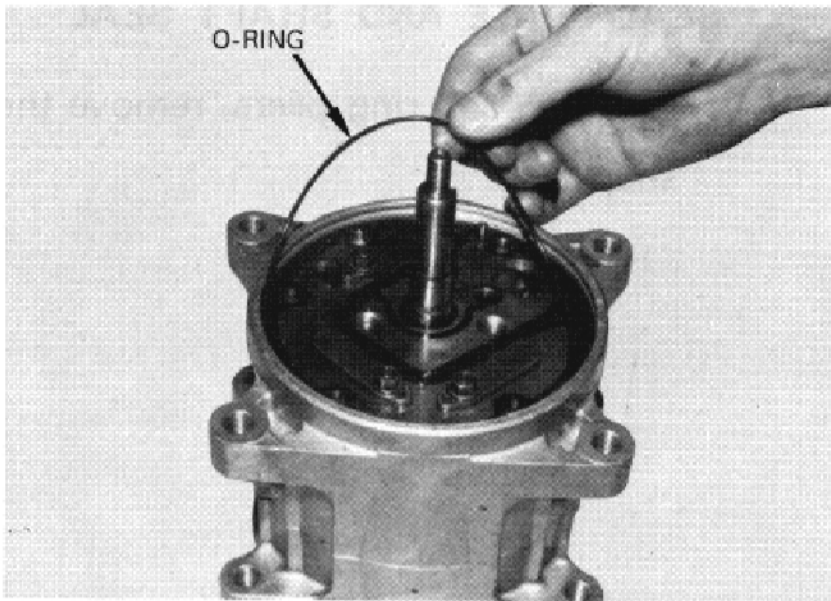

7. REMOVE FRONT VALVE PLATE

A) Remove and discard the O-ring.

B) Remove the dowel pin.

C) Remove the valve plate.
Discard the gasket.

D) Remove the suction reed valve.

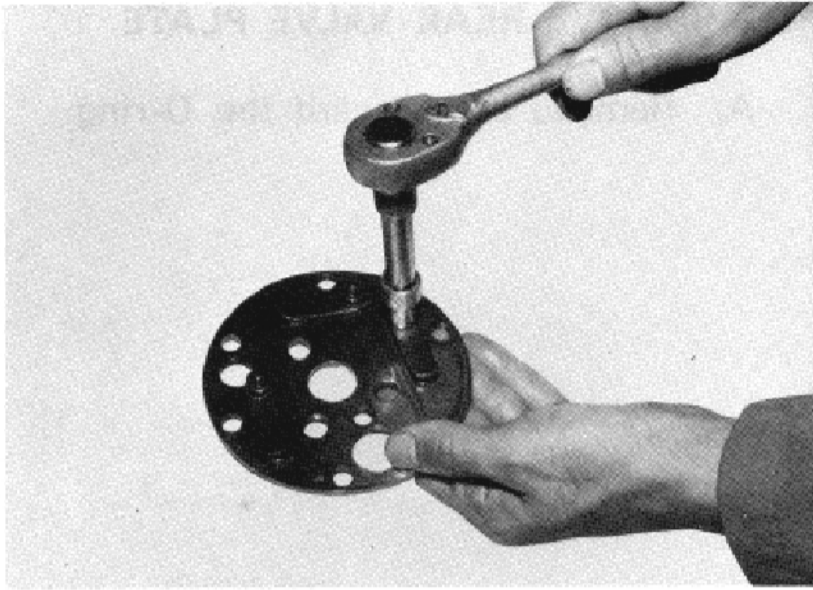

E) Remove the restrainers, from the valve plate.

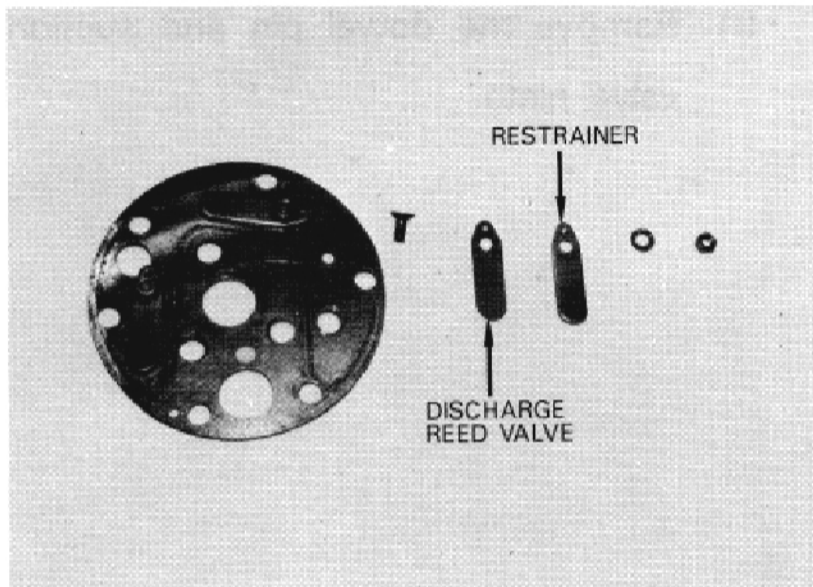

Note: Be sure not to miss the washers and nuts.

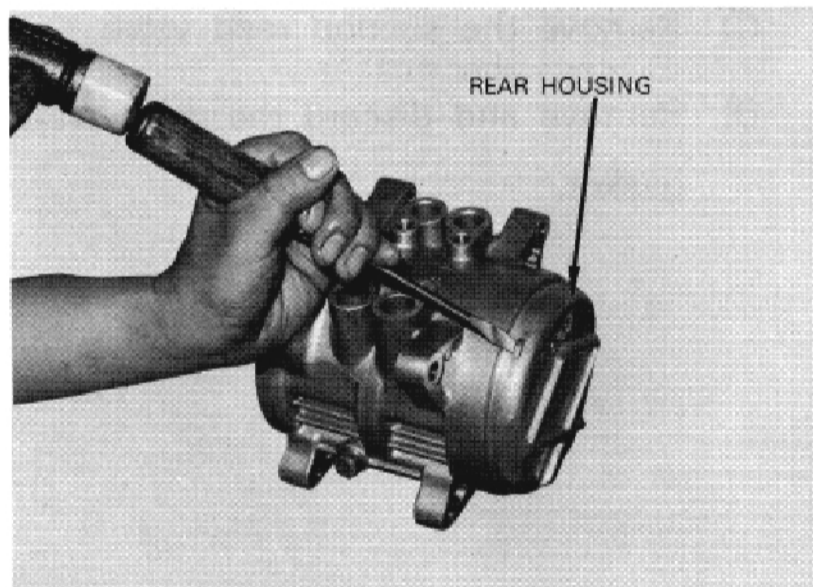

8. REMOVE REAR HOUSING

A) Using a hammer and punch, remove the rear housing by tapping on the protrusion on the rear housing.

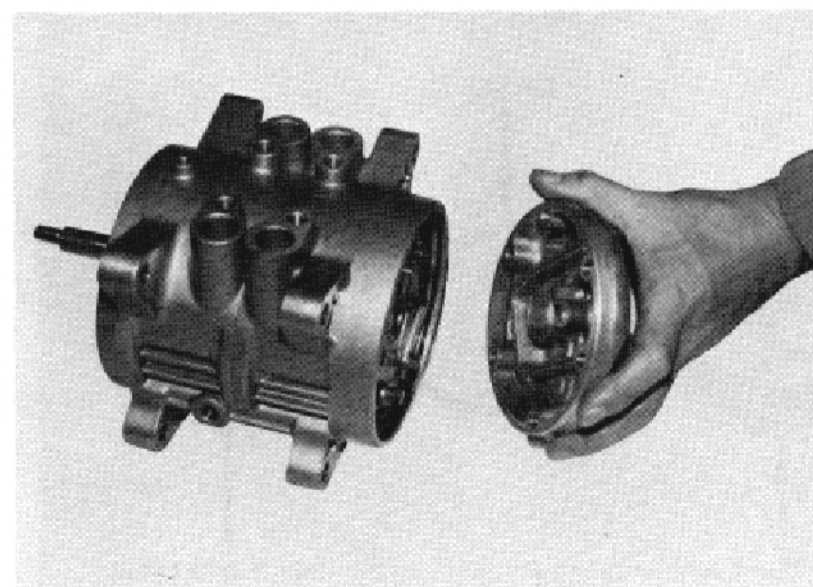

CAUTION: Be careful not to damage or scratch the sealing surface of the rear housing.

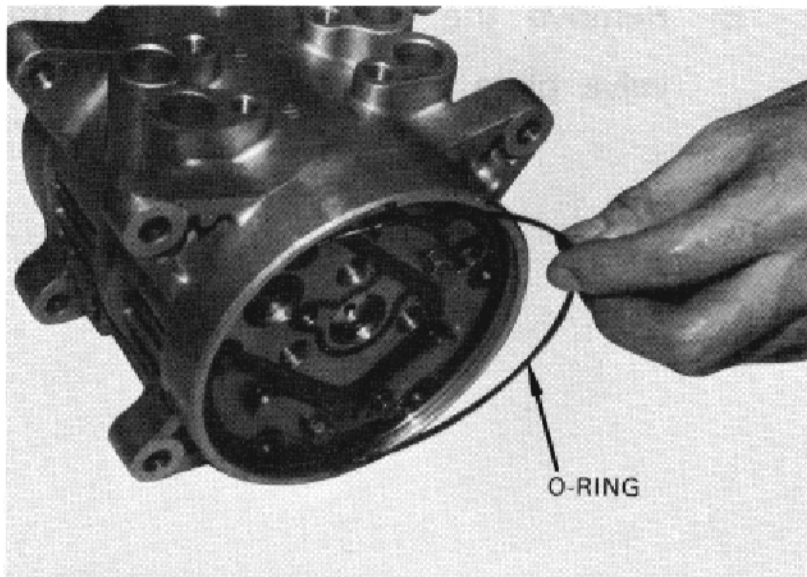

9. REMOVE REAR VALVE PLATE

A) Remove and discard the O-ring.

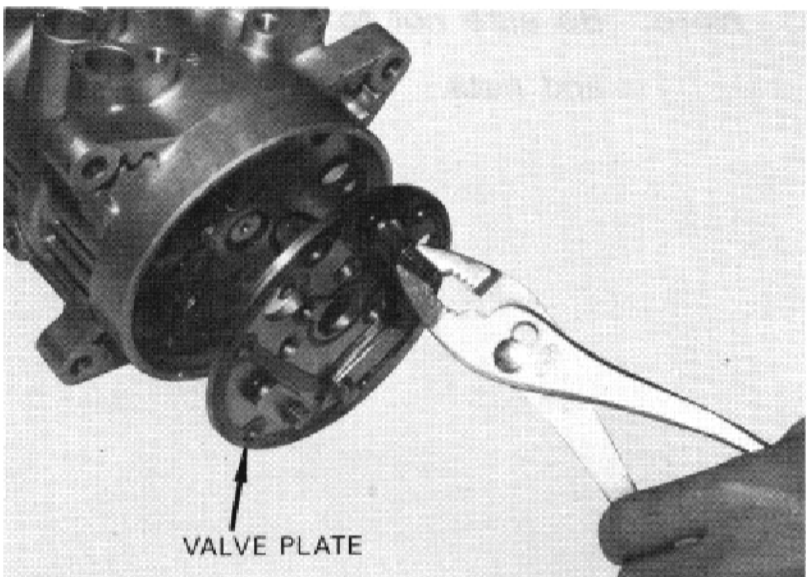

B) Remove the dowel pin and suction valve plate.

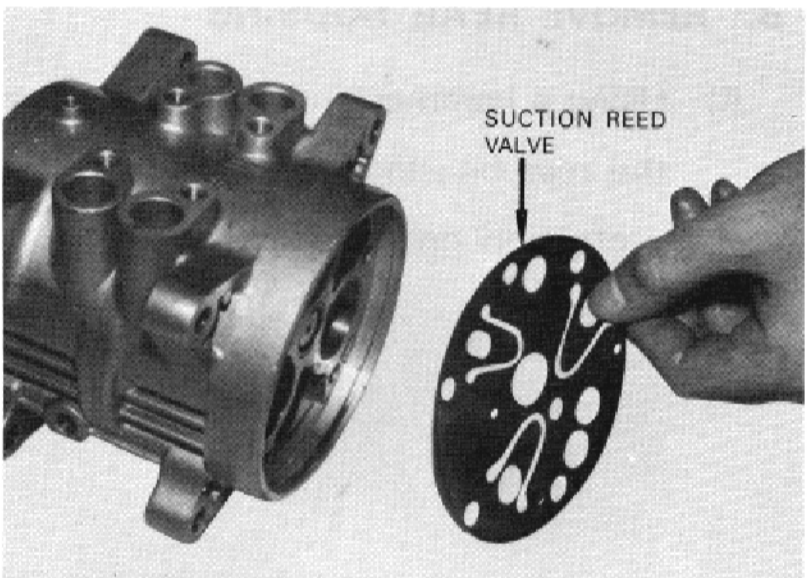

C) Remove the suction reed valve.

D) Remove and discard the valve plate gasket.

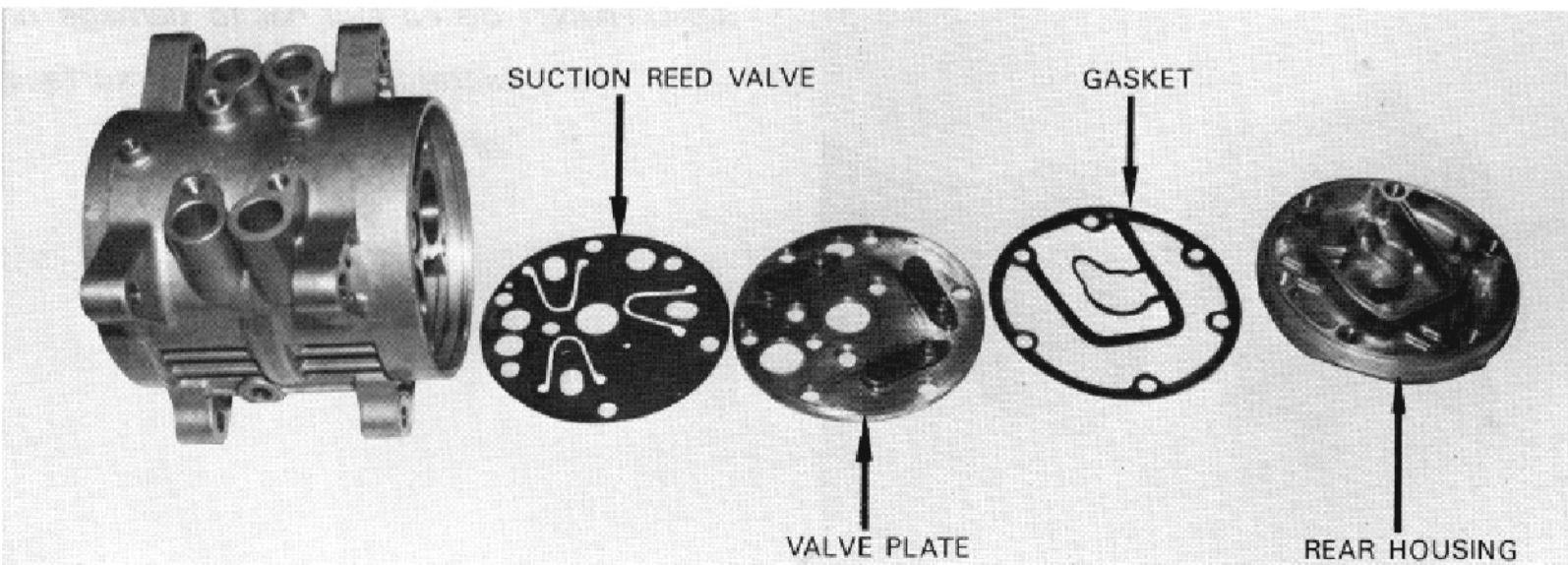

INSPECTION OF COMPRESSOR

PART NAME	INSPECTION ITEMS	REMEDY (If defective:)
SHAFT SEAL	<p>A. Check the lapping surface of carbon disc for crack or scratch.</p> <p>B. Check the rubber seal for crack or hardening.</p> <p>C. Check the spring action.</p>	<p>A. Replace</p> <p>B. Replace</p> <p>C. Replace</p>
SEAL PLATE	<p>A. Check the sealing surfaces for scratch or corrosion.</p>	<p>A. Replace</p>
VALVE PLATE	<p>A. Check both surfaces for scratch or corrosion.</p>	<p>A. Polish with fine oil stone or replace</p>
DISCHARGE REED VALVE	<p>A. Check the reed for crack, scratch, deformation or corrosion.</p> <p>B. Check the restrainer for deformation or corrosion.</p>	<p>A. Replace</p> <p>B. Replace</p>
SUCTION REED VALVE	<p>A. Check the reed for crack, scratch, deformation or corrosion.</p>	<p>A. Replace</p>
FRONT & REAR HOUSINGS	<p>A. Check the sealing surfaces for crack, scratch or deformation.</p>	<p>A. Replace</p>
DISCHARGE & SUCTION SERVICE VALVES	<p>A. Check the flare portion for scratch of deformation.</p> <p>B. Check the groove for O-ring for crack or scratch.</p> <p>C. Check the schrader valve for gas leakage.</p>	<p>A. Replace</p> <p>B. Replace</p> <p>C. Replace</p>

ASSEMBLY OF COMPRESSOR

NOTE: Do not reuse gaskets, O-rings, or washers. Use overhaul kit.

Soak gaskets, O-rings, shaft seal, and seal plate in clean compressor oil.

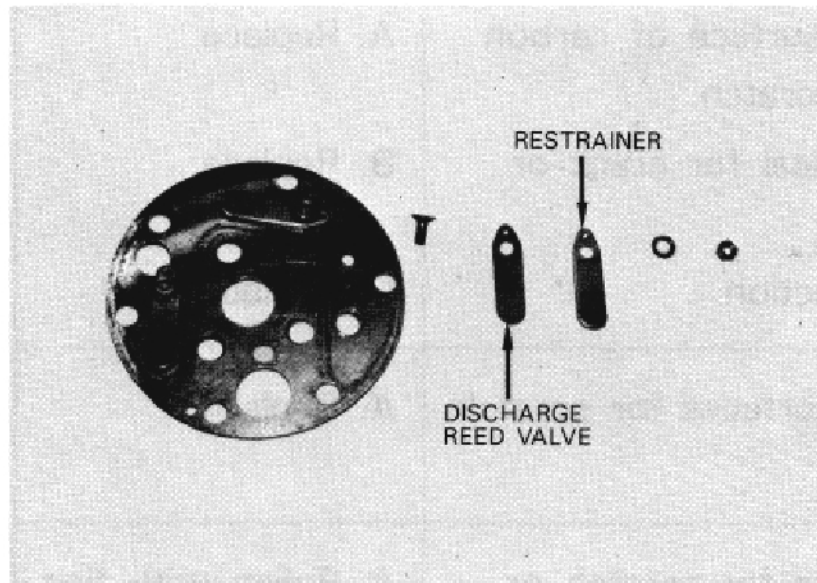

1. DISCHARGE REED VALVE

- A) Assemble new reed valve and restrainer on the valve plate.

STANDARD TORQUE :

40 – 50 kg-cm (3.6 – 4.3 ft-lbs)

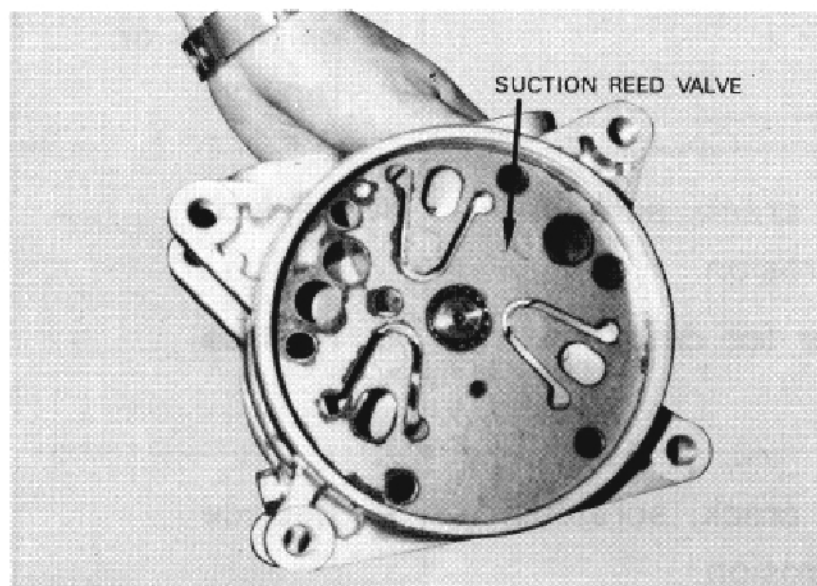

2. INSTALL REAR VALVE PLATE

- A) Install the dowel pin and suction reed valve.

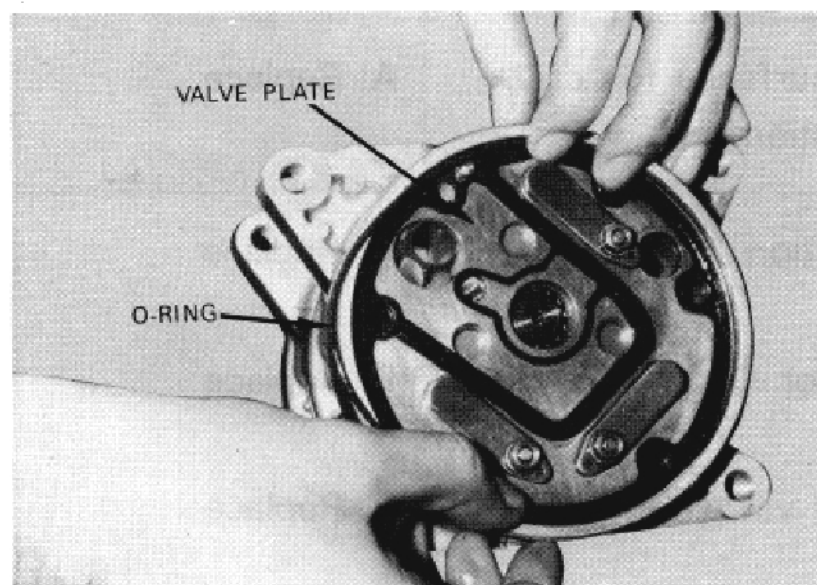

- B) Install the rear valve plate.
- C) Install new gasket and O-ring.
- D) Install the rear housing.

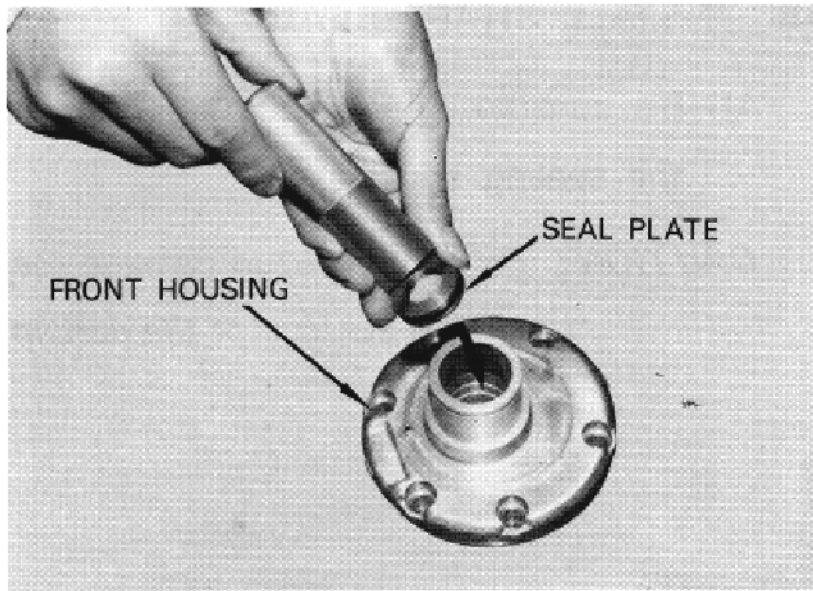

3. INSTALL SEAL PLATE

- A) Put the seal plate into the front housing.
- B) Using the seal plate pressor (SST), press the seal plate until fully seated.

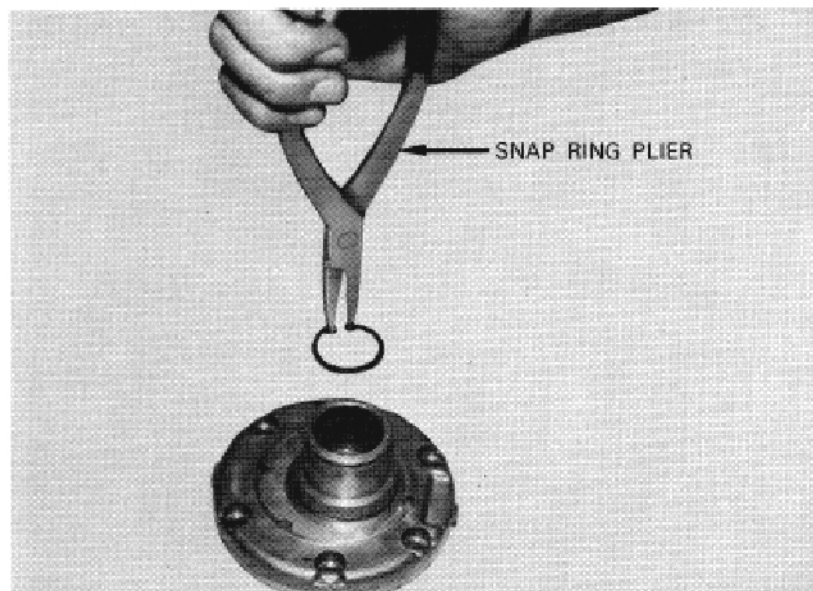

- C) Using the snap ring pliers, install the snap ring.

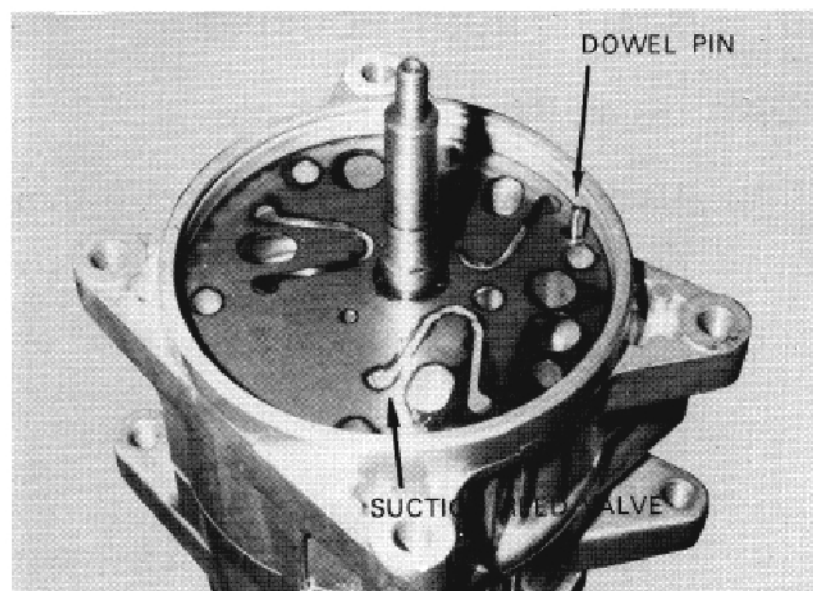

4. INSTALL FRONT VALVE PLATE

- A) Install the dowel pin and suction reed valve.

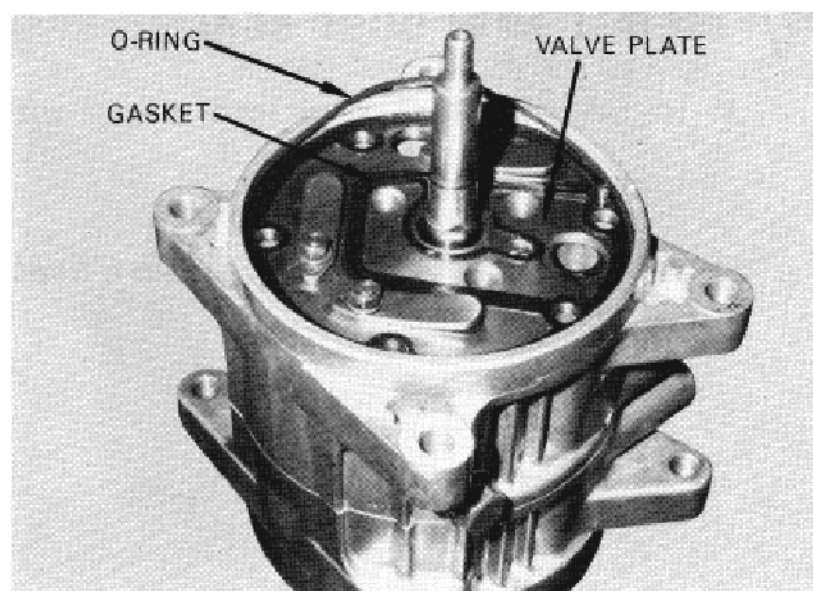

- B) Install the front valve plate.
- C) Install new gasket and O-ring.

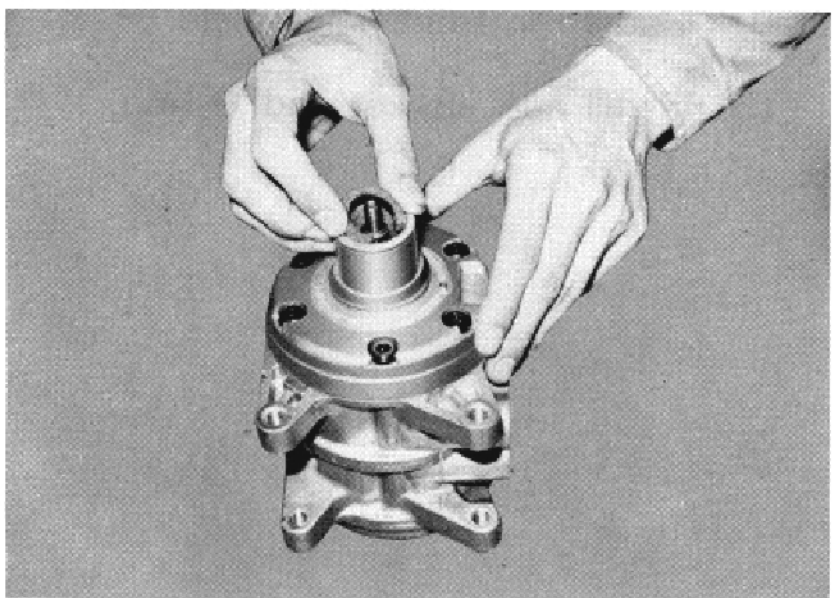
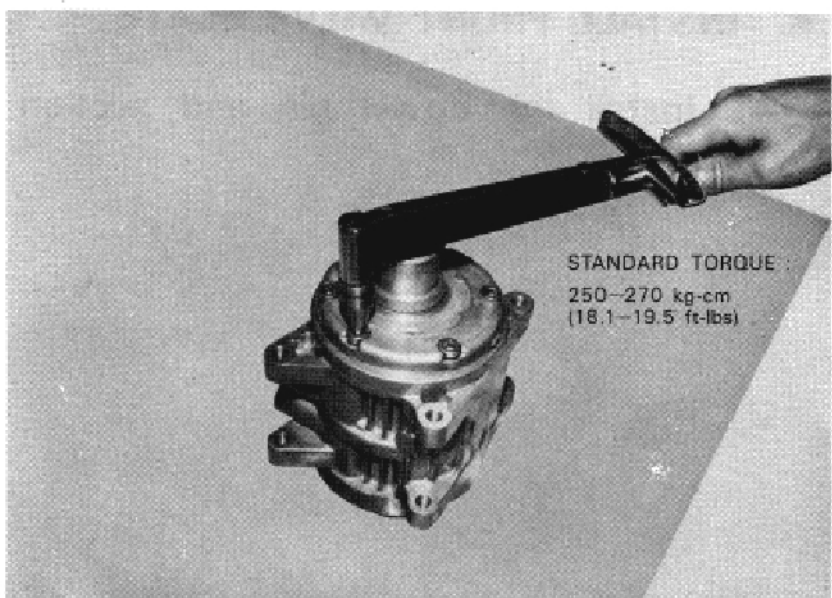
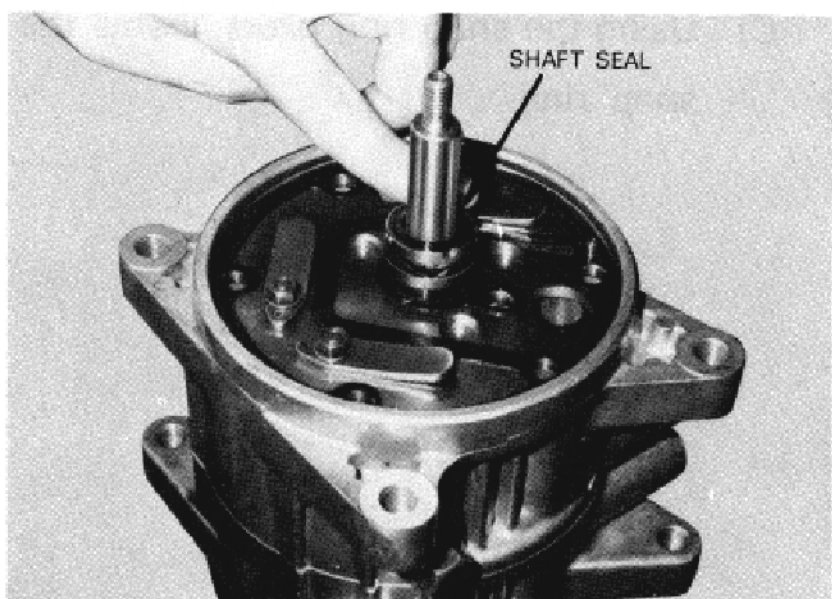
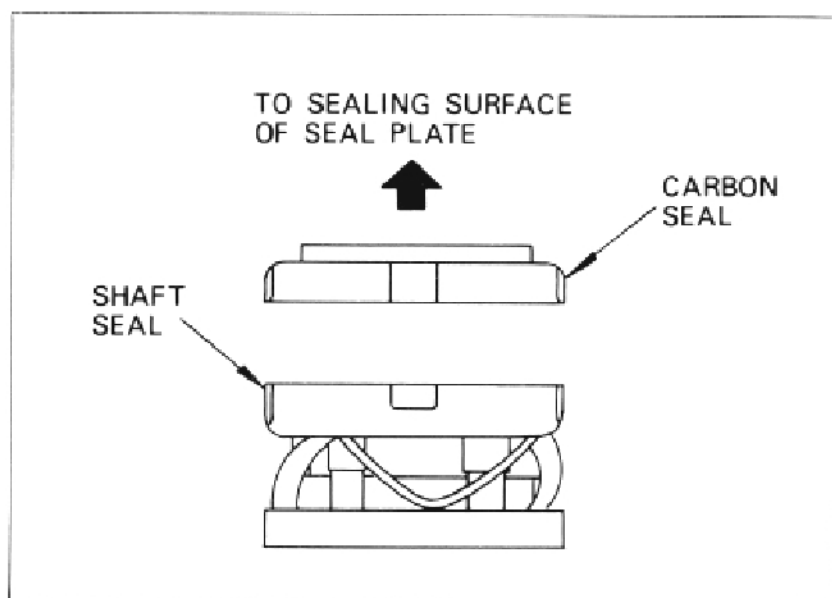

5. INSTALL SHAFT SEAL

- A) Be sure to check the direction of the sealing surface.

CAUTION: Be careful not to damage the sealing surface of the carbon seal.

- B) Install the shaft seal on the shaft.

6. INSTALL FRONT HOUSING

- A) Install the front housing.
- B) Using a torque wrench and 6 mm hex wrench, gradually tighten six through bolts by making two or three passes.

STANDARD TORQUE :

250-270kg-cm (18.1-19.5 ft-lbs)

7. INSTALL NEW DUST SEAL

- A) Install the dust seal into the front housing.

Note: Spring is inside of the dust seal.

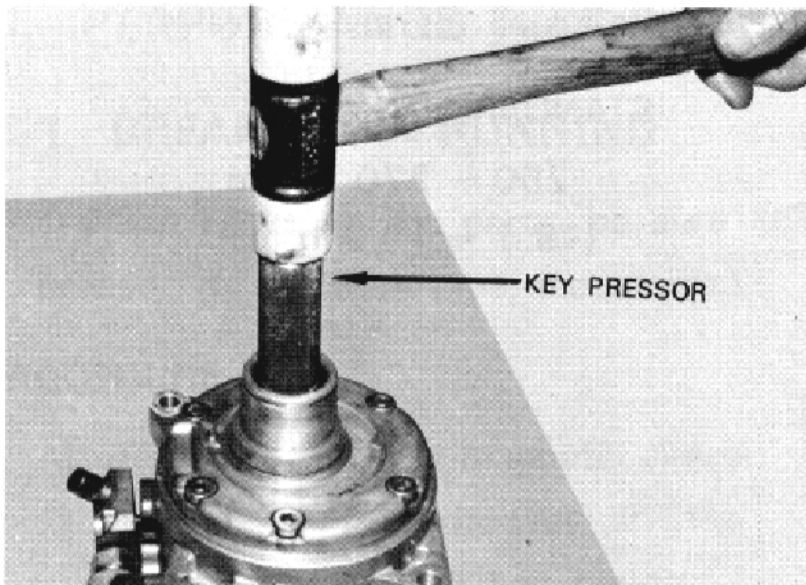

8. INSTALL KEY

- A) Using key pressor and plastic hammer, install the key to the shaft.

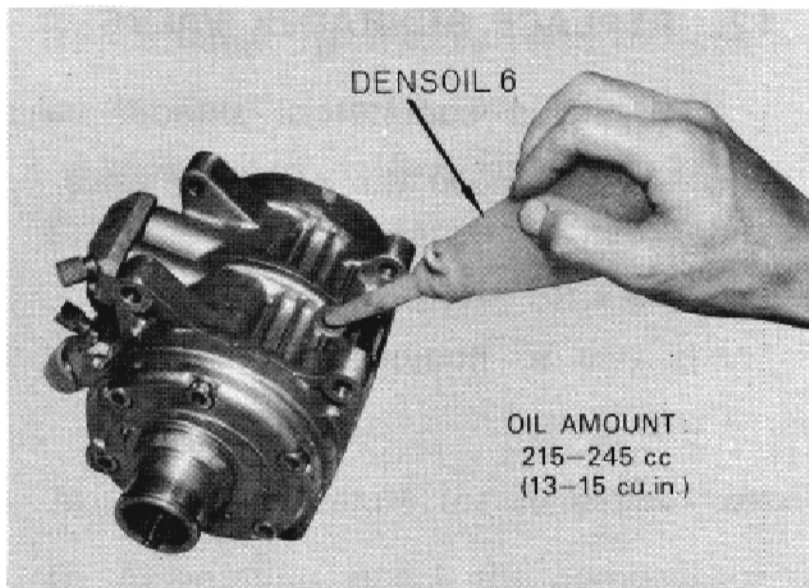

9. POUR COMPRESSOR OIL

- A) Pour compressor oil into the compressor.

OIL SPECIFICATION :

SUNISO 5GS or equivalent

OIL AMOUNT :

215 - 245 cc (13 - 15 cu.in.)

CAUTION: Use specified compressor oil. Wrong kind of oil may cause damage to the air conditioner system.



10. INSTALL OIL PLUG

- A) Install the oil plug with a new washer.

STANDARD TORQUE

210 - 350 kg-cm

(15.2 - 25.3 ft-lbs)

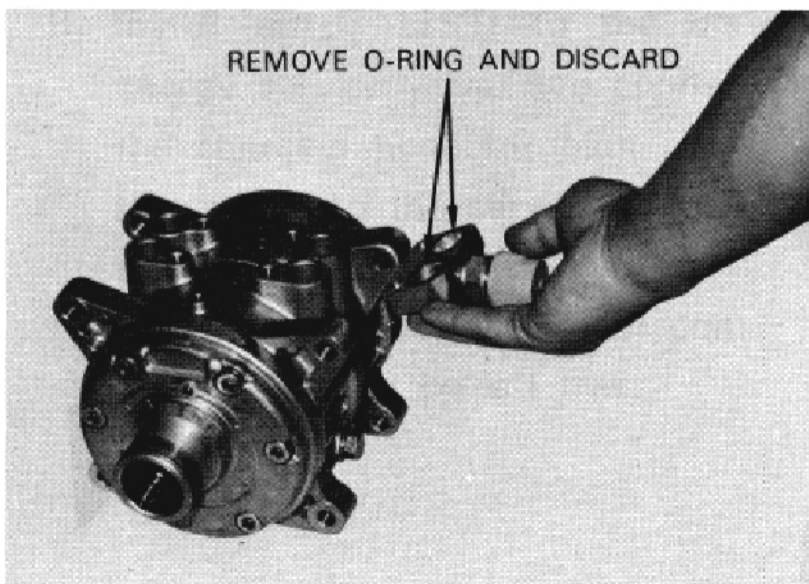

11. REPLACE SERVICE VALVE O-RING

- A) Using a 6 mm hex wrench, remove the service valve.
- B) Remove and discard o-rings.

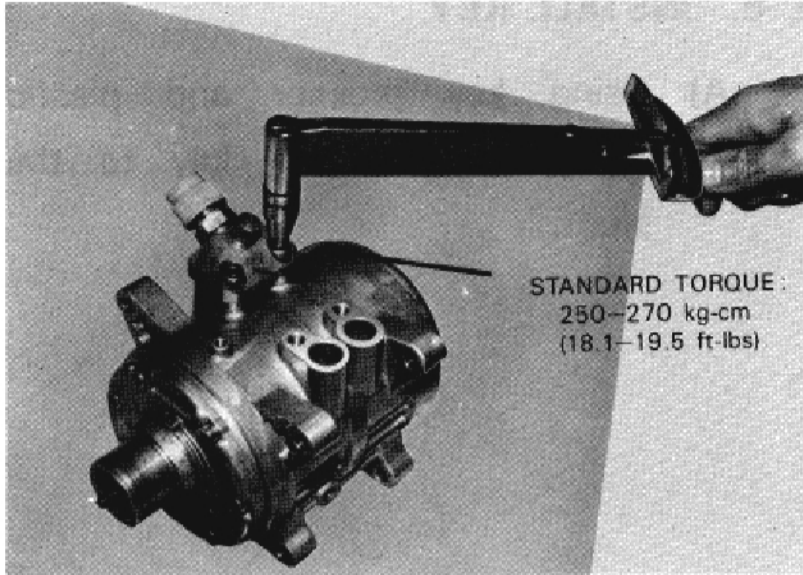

C) Re-install the service valve.

STANDARD TORQUE :

250 – 270 kg-cm
(18.1 – 19.5 ft-lbs)

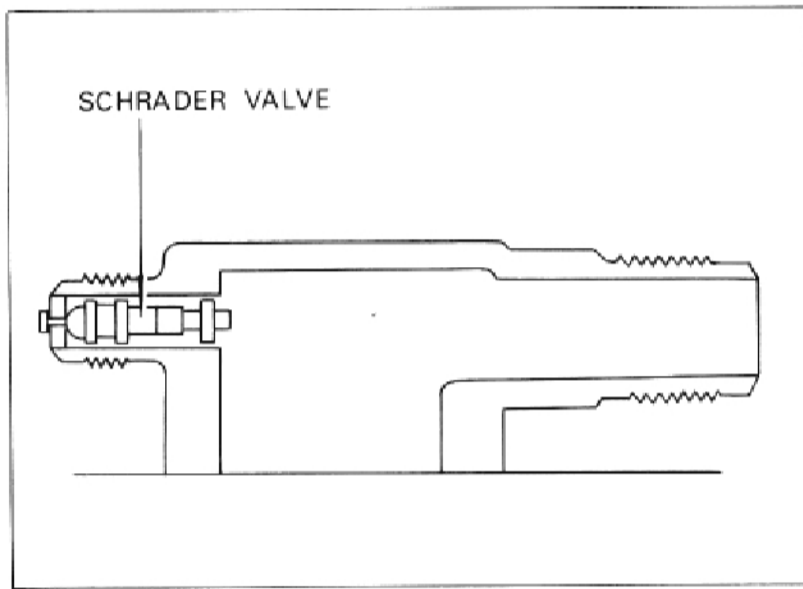

12. REPLACE SCHRADER VALVE

A) Using a commercial schrader valve tool, remove the schrader valve.

VI. PERFORMANCE TEST

VI-1 BREAKING-IN RUNNING

When replacing the parts, be sure to perform the breaking-in running of compressor to get each part accustomed.

PROCEDURE

- A) After installing the magnetic clutch to the compressor, set up the compressor on the test bench.
- B) Connect the flexible hose or tube to the discharge and suction service valves. See Fig. 1.
- C) Engage the magnetic clutch, and rotate the compressor for a quarter under the condition of less than 1000 rpm.

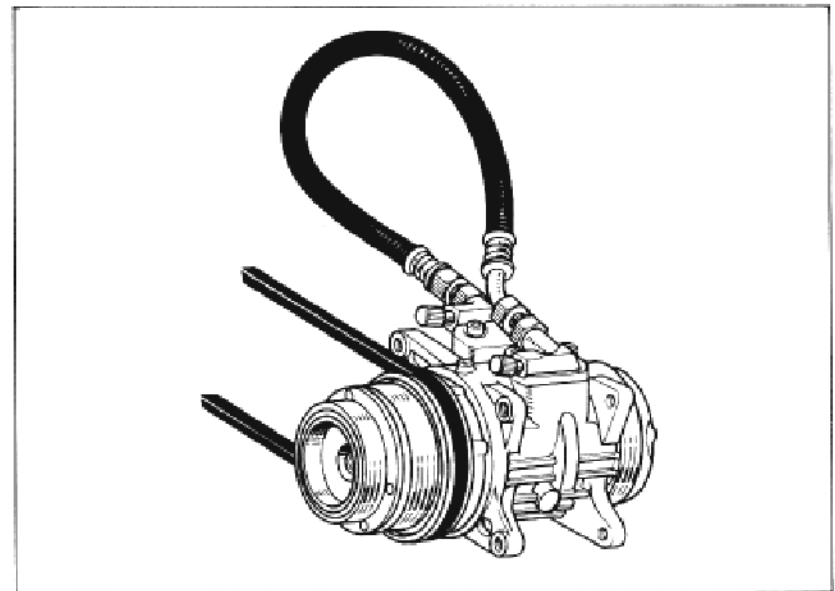

Fig. 1

Note: Never rotate the compressor over 1000 rpm to prevent overheating.

- D) At rotating, check the compressor for unordinarily sound and tone. If the strange noise sounds, disassemble and check the compressor parts especially shoe and ball.

VI-2 VOLUMETRIC EFFICIENCY TEST

PROCEDURE

- A) After installing the magnetic clutch to the compressor, set up the compressor on the test bench or engine.
- B) Install nozzle (SST) to the discharge service valve, and connect the charging hose for high pressure gauge to the service port on the valve.
The suction service valve of compressor should be left free.
See Fig. 2.

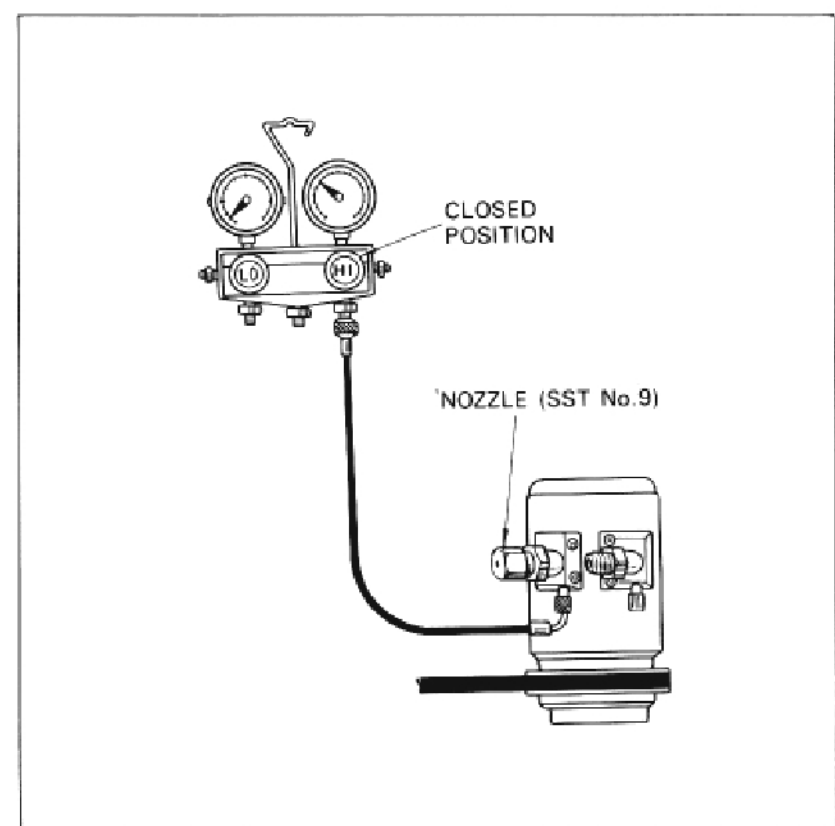

Fig. 2

- C) Start the compressor up to the revolution range shown in Fig. 2, and measure compressor rpm with tachometer.

INDICATION

- A) Lasting approx. 10 seconds after the compressor gets constant speed, the reading of high pressure gauge will be in the oblique lined zone shown in Fig. 3.
- B) If pressure does not come up to the specified range, disassemble and check the compressor. It will be caused by the defective valve plate, reed or gasket.
- C) On the contrary, if the pressure becomes high extremely, check the nozzle hole for small foreign particles.

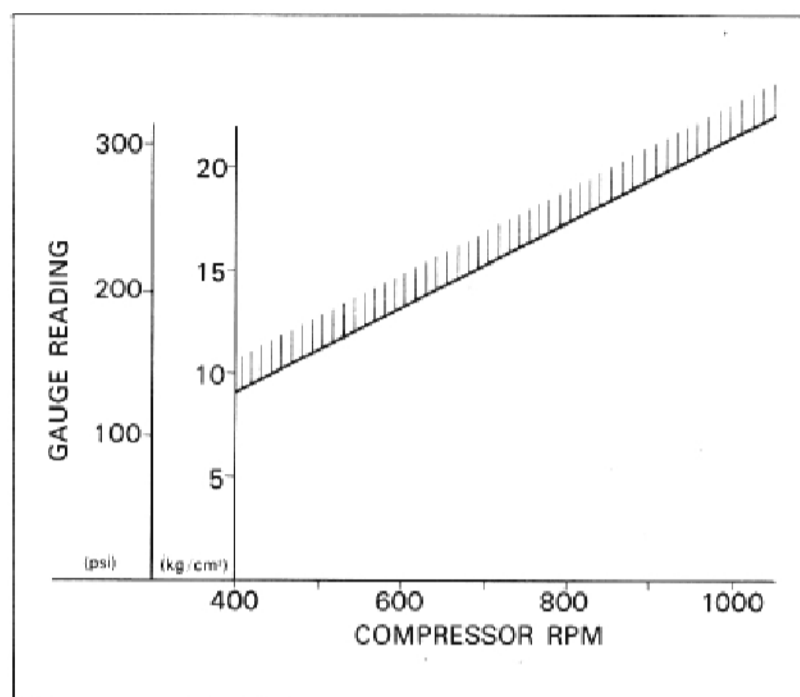

Fig. 3

VI-3 GAS LEAKAGE TEST

PROCEDURE

- A) Put the blind caps on the both service valves to close the service ports.
- B) Charge the refrigerant into the compressor through the charging valve till the pressure raises up to 3 kg/cm² (45 psi.). See Fig. 4.
- C) Check the compressor for gas leakage from the sealed portions using gas leak detector.

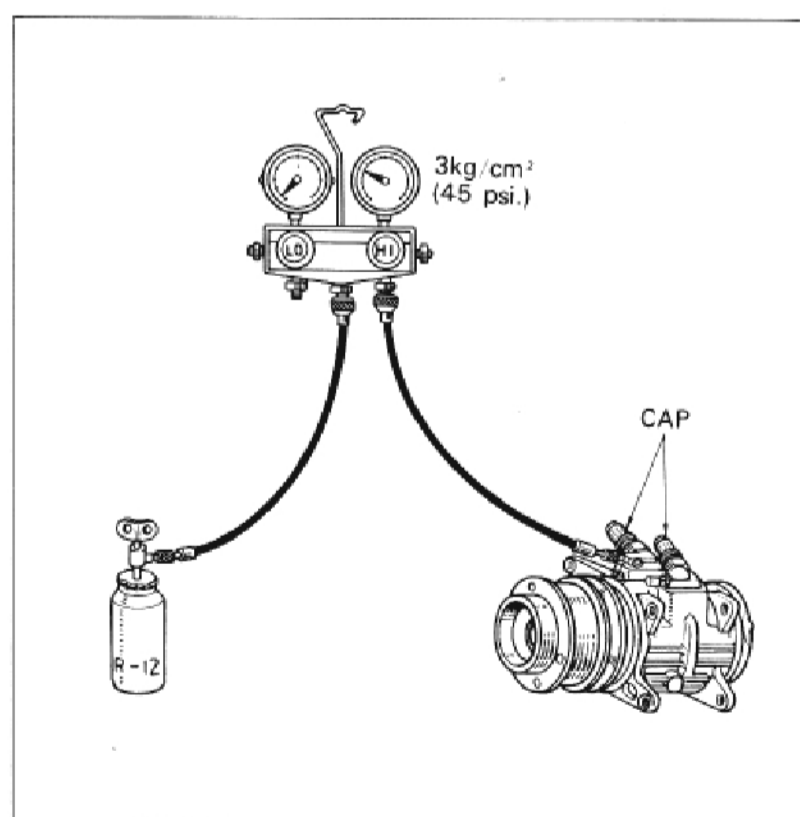

Fig. 4

INDICATION

- A) Finding out gas leakage from sealed portion, check and replace the gasket, O-ring or shaft seal.

VI-4 FINISH

A) Drain the previous compressor oil, and supply clean compressor oil.

Note: 1) Use only approved oil : DENSOIL 6, SUNISO No.5GS or Equivalent.

2) If using the compressor to new system, add the oil up to 215—245 cc (13—15 cu. in.).

B) Evacuate the inside of compressor with vacuum pump for more than 30-minutes, then charge the refrigerant (R-12) into the compressor through the suction service valve.

C) Make sure the caps are tight as free from moisture and contaminates when keeping the compressor.

JANUARY, 1980

No. : RAC-003

Prepared by



NIPPONDENSO CO., LTD.
SERVICE DEPARTMENT

Kariya, Aichi, Japan

No.: 9999-95-012M-80

RAC-003 8001-W-1000 PRINTED IN JAPAN

 NIPPONDENSO CO., LTD.