

The advanced-technology 6-port rotary engine utilizes a sophisticated electronic fuel injection system for maximum optimization of low-end torque with high-speed power while retaining excellent efficiency.

For smoothness of operation, the rotary is unmatched.

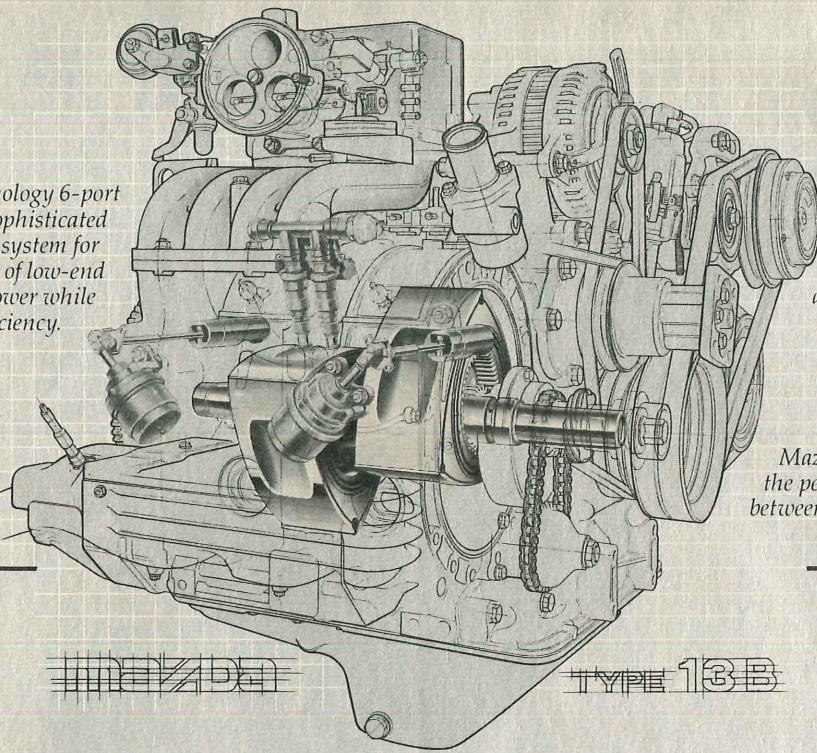

The Mazda 13B rotary of the GSL-SE has more than 14% greater displacement than the 12A version—and 34% more power.

Mazda's rotary strikes the perfect balance between power and weight.

The new Mazda RX-7 GSL-SE.

On paper, it's a higher performance sports car. On a wild west highway, it proves it.

**BOBCAT PASS
ELEV. 9,820 FT.**

There's a lot of country out here. Indian country. Cowboy country. Wild west country. High deserts stretch from sunrise to sunset. Tall mountains climb to an ocean of blue sky and are covered here and there by giant, soft blankets of shadow from clouds just passin' through. Lots of big country here, in northern New Mexico.

It's a country like you won't find anywhere else, and it won't be easy

29 EST. HWY. MPG

18 EST.* MPG

on a sports car. It's always taken somebody, or something, more than just a cut above average to lay claim on the secrets of these mountains, this big country.



So here's the one for chasing those secrets—Mazda RX-7 GSL-SE. The RX-7 needs little explanation, but the GSL-SE is a different matter. If the country around here is like nothing else, so is the GSL-SE, the most special RX-7 yet.

Scaling mountains takes muscle. The GSL-

SE has the biggest of Mazda's rotary engines, the 13B. It's the street version of the powerplant that won the GTO category at the Daytona 24-hour endurance race the last two years running. For the GSL-SE, it features an innovative new six-port layout, fed by a sophisticated electronic fuel-injection system. At

low speeds, the mixture of fuel and air flows through smaller ports, thus maintaining optimum flow rates for maximum efficiency and sharp response. As engine speed increases, additional ports admit more mixture, increasing the total breathing area for exceptional upper-end performance. And

*EPA estimates for comparison. Your mileage may vary with trip length, speed and weather. Highway mileage will probably be less. Mazda's rotary engine licensed by NSU-WANKEL.

Engine placement behind front-wheel centerline gives a near 50-50 weight distribution.

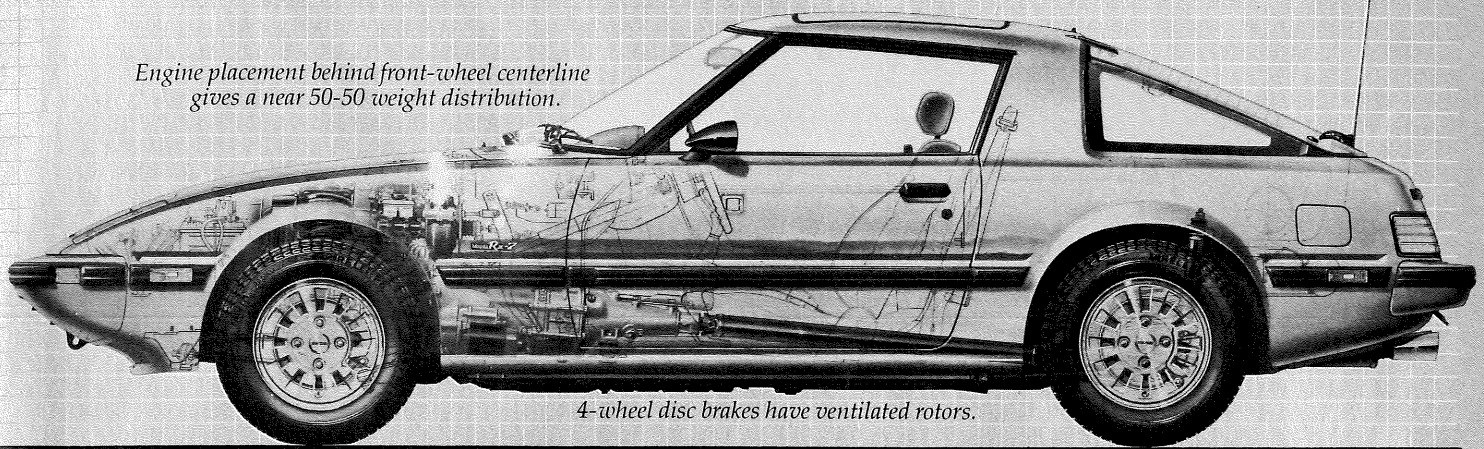

4-wheel disc brakes have ventilated rotors.

upstream of the engine proper, the fuel-injection utilizes tuned intake tubes and a unique surge tank that impart dynamic pressure to the intake charge and further enhance both power and efficiency.

The result of all this advanced technology is loads of punch throughout the engine speed range, 34 percent more power than the 12A engine in the standard RX-7 and no appreciable drop in fuel economy.

The result is, in a word, pretty amazing.

Underneath is a

MAZDA RX-7 GSL-SE

ACCELERATION

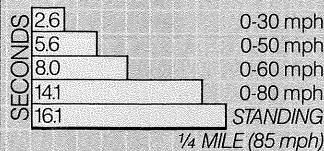

BRAKING



P6 radials.

This is a serious car, folks.

For the serious drive. In northern New Mexico, the desert floor starts at 7000 feet, moun-

tain passes flirt with two miles high. Switchbacks climb those peaks like a chain of evil-tempered rattlesnakes. Just

like always, the timid can pass through but better be careful. But if a car's got the power to climb those mountains, the chassis to tame those rattlers, then it can chase the frontier in this wild west country.

Take Highway 64 south out of Taos, crest the Palo Flechado Pass at

9107 feet, it says, then corkscrew a descent that jumbles down the mountains with all the order of a runaway rock slide. Go north to Eagle Nest, then Highway 38 to all 9820 feet of Bobcat Pass, and another spiraling drop into Red River. In the old days, they would chain a tree to the back of a wagon and drag it through the dusty trail to slow their descent.

Now—you just yee-haw! that 13B EGI (Electronic Gasoline Injection) with a soft spur on the throttle pedal and the

strong grip on the crooked necks of all those switchbacks and just manhandle them into behaving.

If it's tall, big country for high driving adventure you're after, exploring the frontier of what a sports car is all about, the mountains of northern New Mexico will hold the same lure for you they did for Kit Carson. The forest in these mountains was named after him, but with the GSL-SE version of Mazda's RX-7, you'll own no small part of it for yourself.

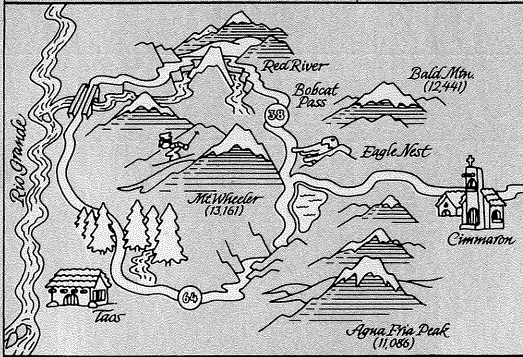

chassis to match. Detail refinements to the rear suspension, in the location of rear axle control links, increase the handling limits. The disc brakes have ventilated rotors at all four wheels for maximum cooling. And the alloy wheels are mounted with P205/60VR14 Pirelli-



On the Pro Rally circuit, Rod Millen's Mazda RX-7 with race-prepared 13B rotary engine is a dominant factor, always running near the front. This spring it won the Olympus International event.

uphill side goes flat, then latch those ventilated brakes to the pavement and never mind dragging a big tree along behind.

And as for those angry rattlesnakes, the Pirelli P6 tires take a

Send for a Free RX-7 Catalog

To find out even more about this and all the other Mazda RX-7's, send your name, address, city, state and zip code to the following address and mention that you'd like the RX-7 catalog.

Mazda RX-7 Offer
P.O. Box 5960
Orange, California 92668

Mazda

THE MORE YOU LOOK,
THE MORE YOU LIKE.

Experienced drivers buckle up.