

FUEL, INTAKE, EXHAUST AND EMISSION CONTROL SYSTEM (12A ENGINE)

SYSTEM DIAGRAM	4A- 2
EMISSION CONTROL SCHEMATIC DIAGRAM	4A- 3
COMPONENT DESCRIPTIONS	4A- 5
OUTLINE OF CONSTRUCTION	4A- 9
EMISSION CHECKING PROCEDURE	4A-15
VACUUM HOSE ROUTING DIAGRAM	4A-21
SPECIFICATIONS	4A-22

SYSTEM DIAGRAM

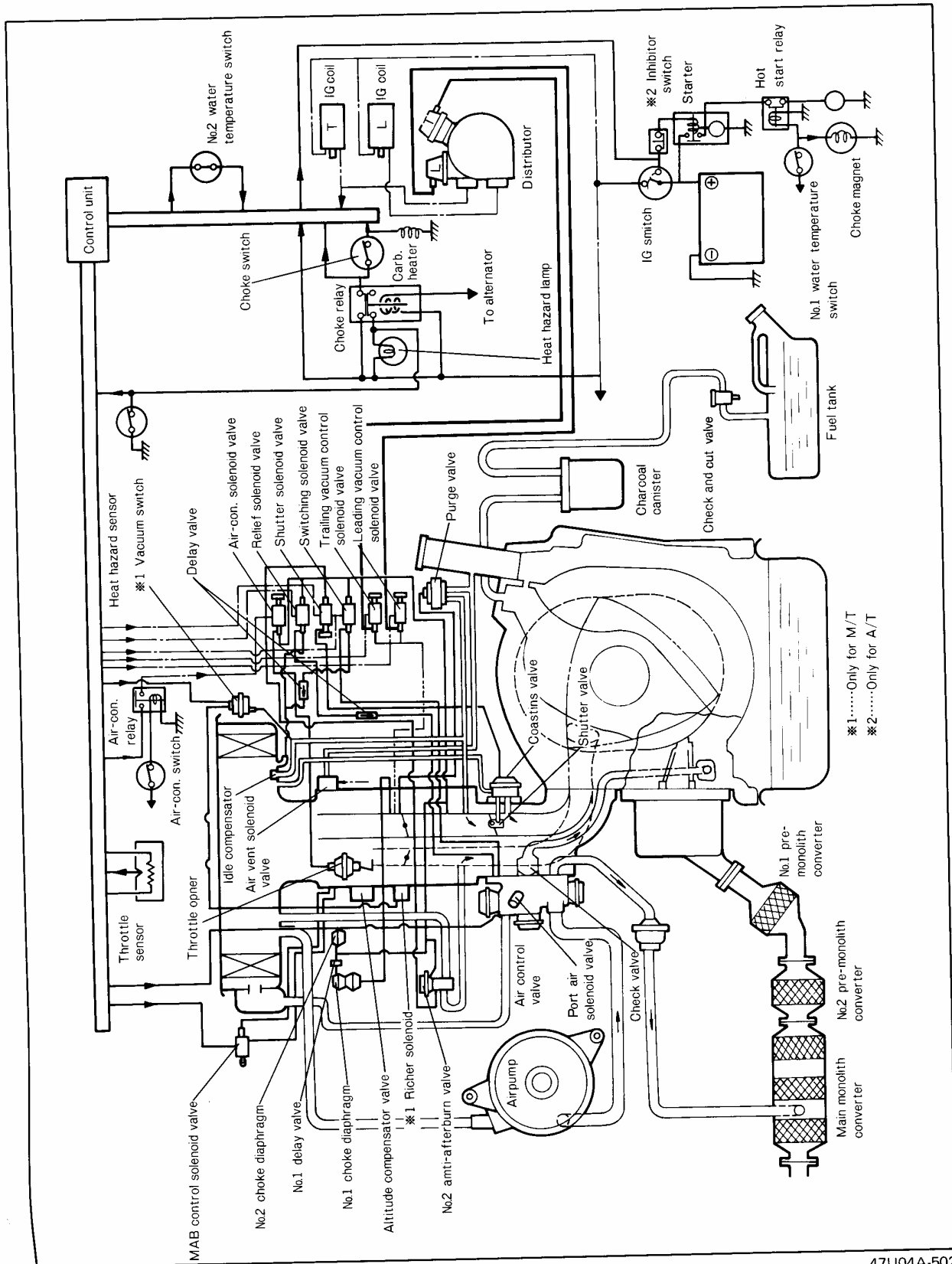

EMISSION CONTROL SCHEMATIC DIAGRAM

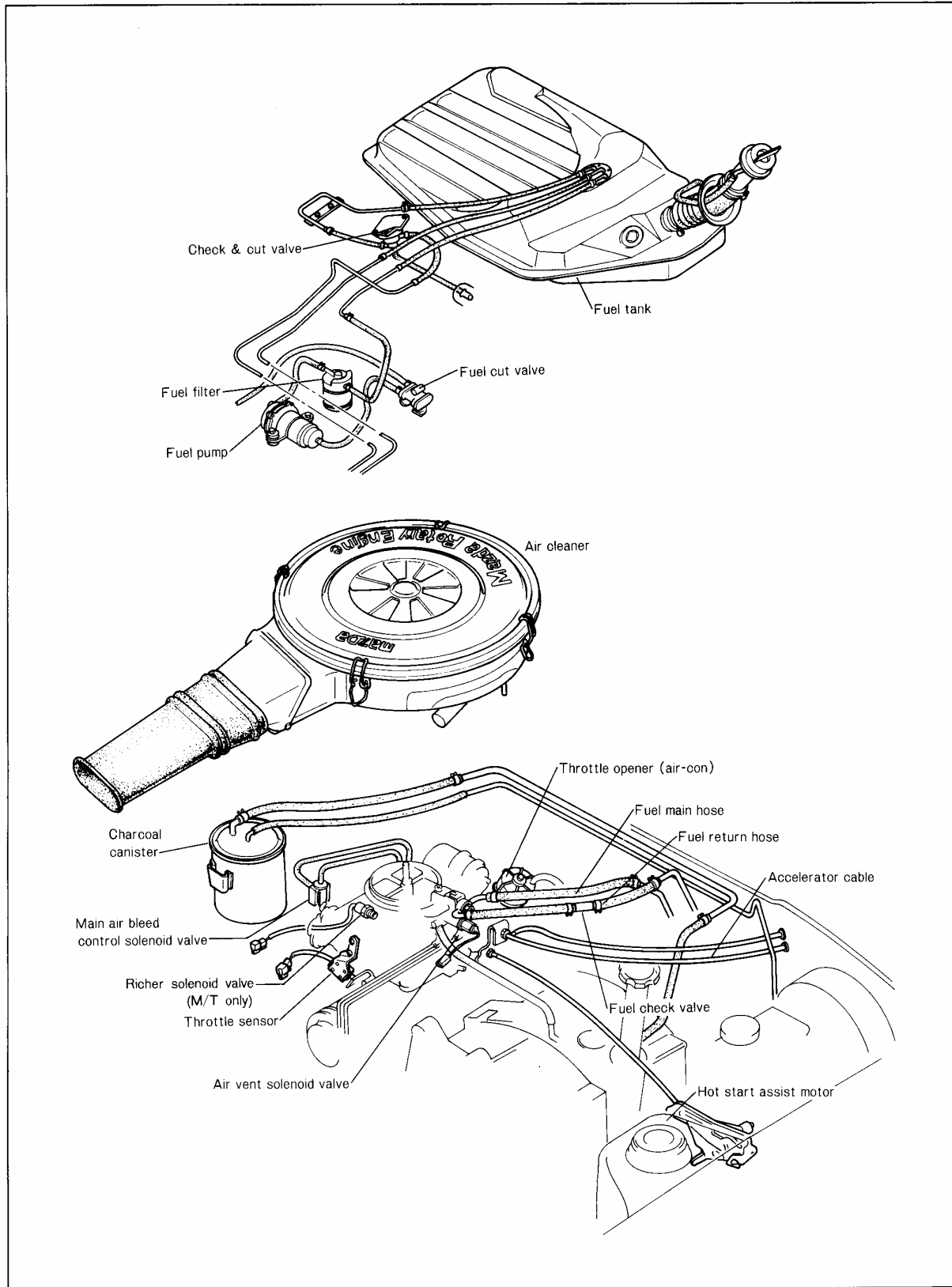

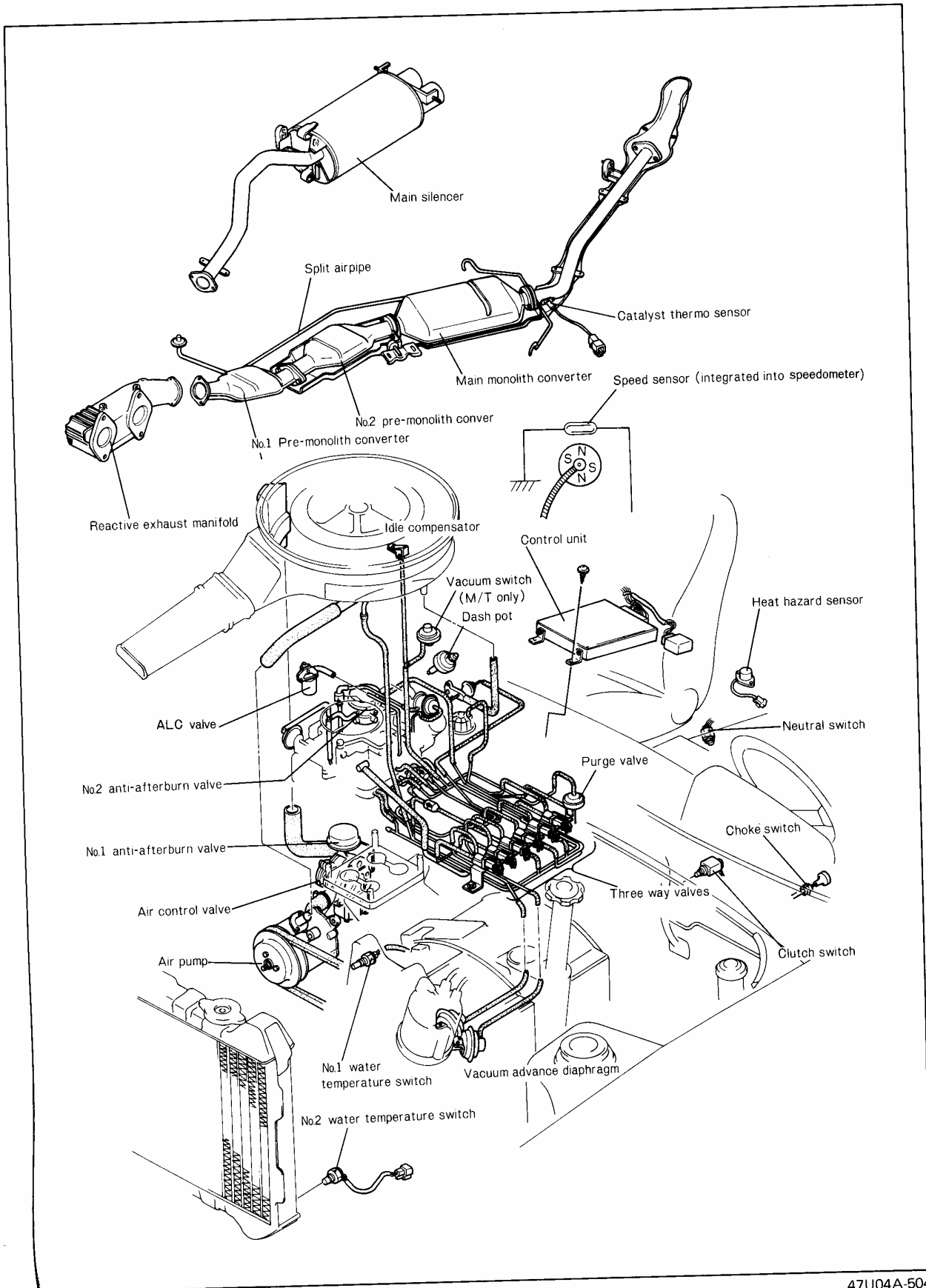

47U04A-504

COMPONENT DESCRIPTIONS

Component	Function	Remarks
1. Anti-Afterburn Valve (No. 1)	Supplies fresh air into the front primary port during deceleration	Included in air control valve; vacuum operated
2. Anti-Afterburn Valve (No. 2)	Supplies fresh air into the rear secondary port during deceleration	Vacuum operated
3. A/C Solenoid Valve	Applies vacuum to the throttle opener when A/C switch is turned on	White
4. Air Cleaner	Filters air into carburetor	
5. Air Control Valve (ACV)	Directs air to one of three locations: Exhaust port, 3-bed catalyst or back to the air cleaner	Consists of 3 valves: Air relief valve Air switching valve No. 1 AAV
6. Air Pump	Supplies secondary air to ACV	
7. Air Vent Solenoid Valve	Vents float chamber to the canister while the engine stops	When the engine is started, the fumes are drawn into the intake manifold through purge valve
8. ALC Valve	Leans the mixture at high altitude	Adds air to carburetor air bleeds
9. Canister	Stores gas tank and carburetor fumes when engine stops	Vented to atmosphere through charcoal and filter
10. Catalyst Thermo Sensor	Detects exhaust gas temperature; sends signal to control unit	Rear exhaust pipe of rear catalyst opens when: 770°C (1418°F) . . . M/T 740°C (1364°F) . . . A/T
11. Check and Cut Valve	Releases excessive pressure or vacuum in the fuel tank to atmosphere Prevents fuel loss if the vehicle is overturned	

47U04A-505

COMPONENT DESCRIPTIONS

Component	Function	Remarks
12. Choke Bimetal Heater	Gradually opens the choke valve after engine is started	ON: after engine is started with choke OFF: when choke returns to off position
13. Choke Diaphragm (No. 1)	Pulls choke valve partially open after delay valve opens or when accelerating (ported vacuum)	2 diaphragms, connected to choke bimetal
14. Choke Diaphragm (No. 2)	Forces the choke valve to open a little after engine is started	1 diaphragm connected to choke valve
15. Choke Switch	Applies power to choke heater, controls secondary air injection and distributor vacuum advance through control unit	Pull knob out above 10 mm (0.4 in): closed
16. Clutch Switch and Neutral Switch (only for MT/)	Detect in-gear condition	Closes when clutch pedal is depressed; opens when clutch pedal is released Closes in neutral; opens in all other ranges
17. Coasting valve	Supplies fresh air into the rear primary port when decelerating to prevent excessive vacuum	
18. Control Unit	<p>Detects the following:</p> <ol style="list-style-type: none"> 1 Engine speed 2 Radiator coolant temperature 3 Throttle opening 4 Choke condition 5 Floor temperature 6 Air conditioner ON/OFF condition 7 Exhaust gas temperature 8 Vehicle speed <p>Controls operation of the following:</p> <ol style="list-style-type: none"> 1 Vacuum control solenoid valve (T) 2 Vacuum control solenoid valve (L) 3 Switching solenoid valve 4 Shutter solenoid valve 5 Relief solenoid valve 6 Air con. solenoid valve 7 Port air solenoid valve 8 Main air bleed control solenoid valve 9 Richer solenoid valve 10 Fuel pump cut relay 	<ol style="list-style-type: none"> 1 Ignition coil - terminal 2 No. 2 water temperature switch 3 Throttle sensor 4 Choke switch 5 Heat hazard sensor 6 Air con. switch 7 Thermo sensor 8 Speed sensor

47U04A-506

COMPONENT DESCRIPTIONS

RX-7 **4A**

Component	Function	Remarks
19. Dash Pot	Gradually closes throttle during deceleration	Contacts at 3,800 ~ 4,200 rpm (in neutral)
20. Delay Valve	Delays switching valve operation from port air to split air	Delay time: 0.8 ~ 1.5 sec.
21. Delay Valve	Delays relief valve operation from relief air to injection air	Delay time: 0.8 ~ 1.5 sec.
22. Heat Hazard Sensor	Detects floor temperature and sends signal to control unit	Closes above 130°C (266°F) When heat-hazard sensor is closed; relieves secondary air
23. Idle Compensator	Keeps idle constant with temperature change	Operation temperature: 65°C (149°F)
24. Main Air Bleed Control Solenoid Valve	Opens air passage and leans the mixture during acceleration at a certain speed	Adds air to primary main air bleed Opens air passage when; Engine speed: 3,000 ~ 4,000 rpm Vehicle speed: above 50 MPH
25. No. 1 Pre-monolith Converter	Reduces HC and CO	Oxidizing catalyst
26. No. 2 Pre-monolith Converter	Reduces HC, CO and NO x	3 Way catalyst
27. Port Air Solenoid Valve	Closes port air by-pass passage during acceleration at a certain speed	Closes port air by-pass passage when; Engine speed: 3,000 ~ 4,000 rpm Vehicle speed: above 50 MPH
28. Purge Valve	Carries evaporative fumes from gas tank and canister to intake manifold	During open throttle
29. Relief Solenoid Valve	Relieves secondary air to air cleaner when unnecessary	Blue
30. Richer Solenoid Valve (only for M/T)	Opens primary fuel passage after decelerating	Operates for 30 seconds when the engine speed becomes 1,100 rpm or less

Component	Function	Remarks
31. Shutter Solenoid Valve	Operates coasting valve during deceleration above 1,100 rpm Operates shutter valve at the same time	Yellow
32. Shutter Valve	Shuts off the rear primary port during deceleration	
33. Speed Sensor	Detects vehicle speed	Reed switch; integrated into speedometer
34. Split Air Injection Pipe	Secondary air injected into main converter between center monolith and rear monolith Above 1,100 rpm with open throttle and choke off	
35. Switching Solenoid Valve	Switches the secondary air to exhaust port or rear catalyst	Gray
36. Throttle Opener	Pulls the throttle valve partially open when A/C switch is turned on	Compensates for load of compressor During air-con. operation; 1,200 rpm (neutral)
37. Throttle Sensor	Detects the throttle opening angle	
38. Vacuum Advance Diaphragm	Controlled by solenoid valve	
39. Vacuum Control Solenoid Valve	Cut vacuum to distributor during deceleration, etc.	Leading: Brown Trailing: Green
40. Vacuum Switch (only for M/T)	Detects intake manifold vacuum	Opens at intake manifold vacuum of 0 ~ 120 mmHg (0 ~ 4.7 inHg)
41. Water Temperature Switch (No. 1)	Holds choke on below 70°C Operates hot start motor above 70°C	On the water pump body Below 70°C (158°F): closed
42. Water Temperature Switch (No. 2)	Detects radiator coolant temperature; sends signal to control unit	Above 15°C (59°F): closed
43. 3-bed Monolith Converter	Further reduces HC, CO and NO x	3 Way catalyst (Main converter)

OUTLINE OF CONSTRUCTION

The system modified from the 1983 model is explained below.

1. SECONDARY AIR CONTROL SYSTEM

Port Air Solenoid Valve

The newly-added port air by-pass passage is opened and closed in accordance with the engine speed or the vehicle speed, and controls the amount of by-pass air at the split air.

Operation:

When the engine speed is 3,000 ~ 4,000 rpm or the vehicle speed is above 50 MPH, the port air by-pass passage is closed to prevent the overheat of catalyst converter.

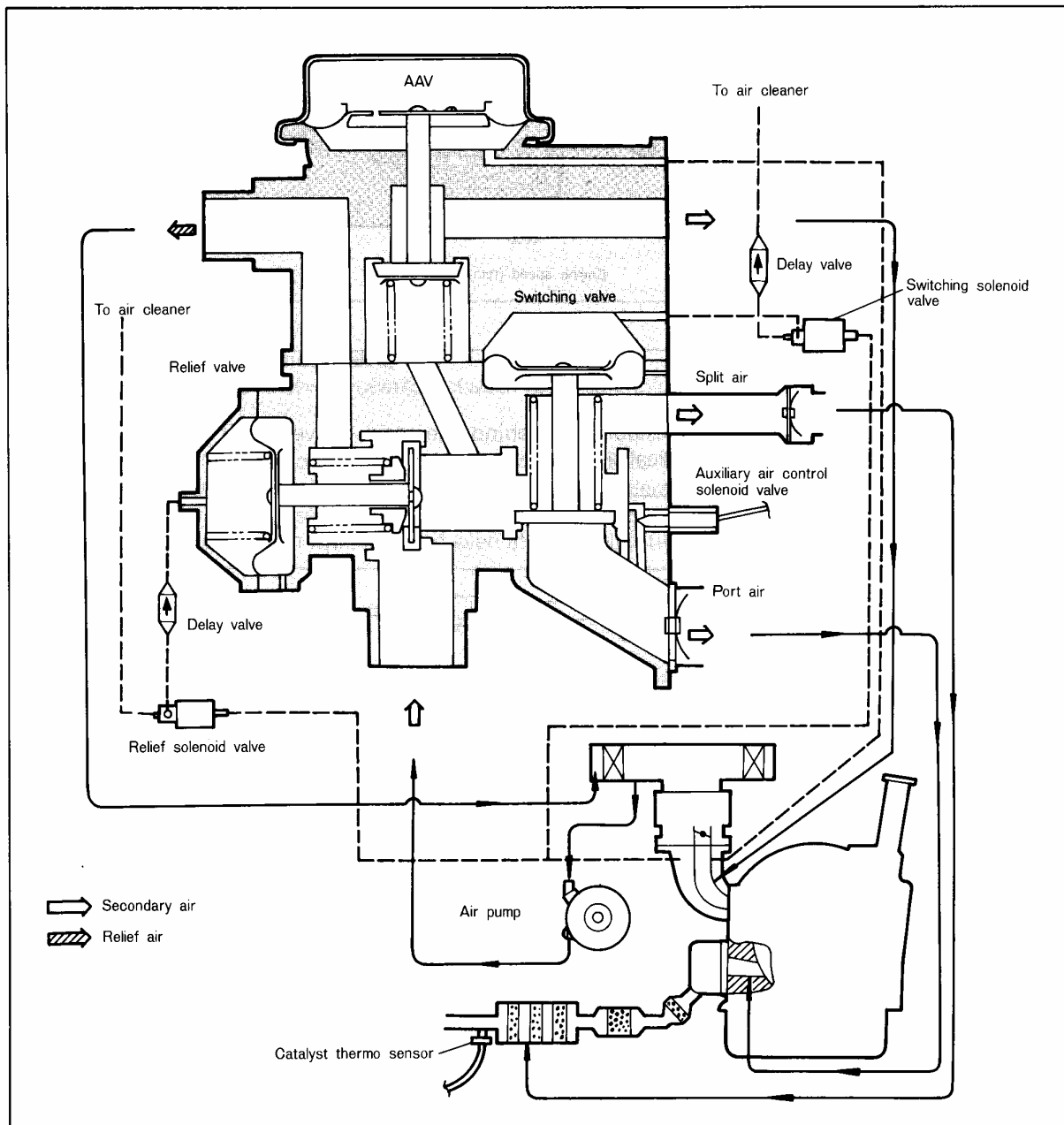

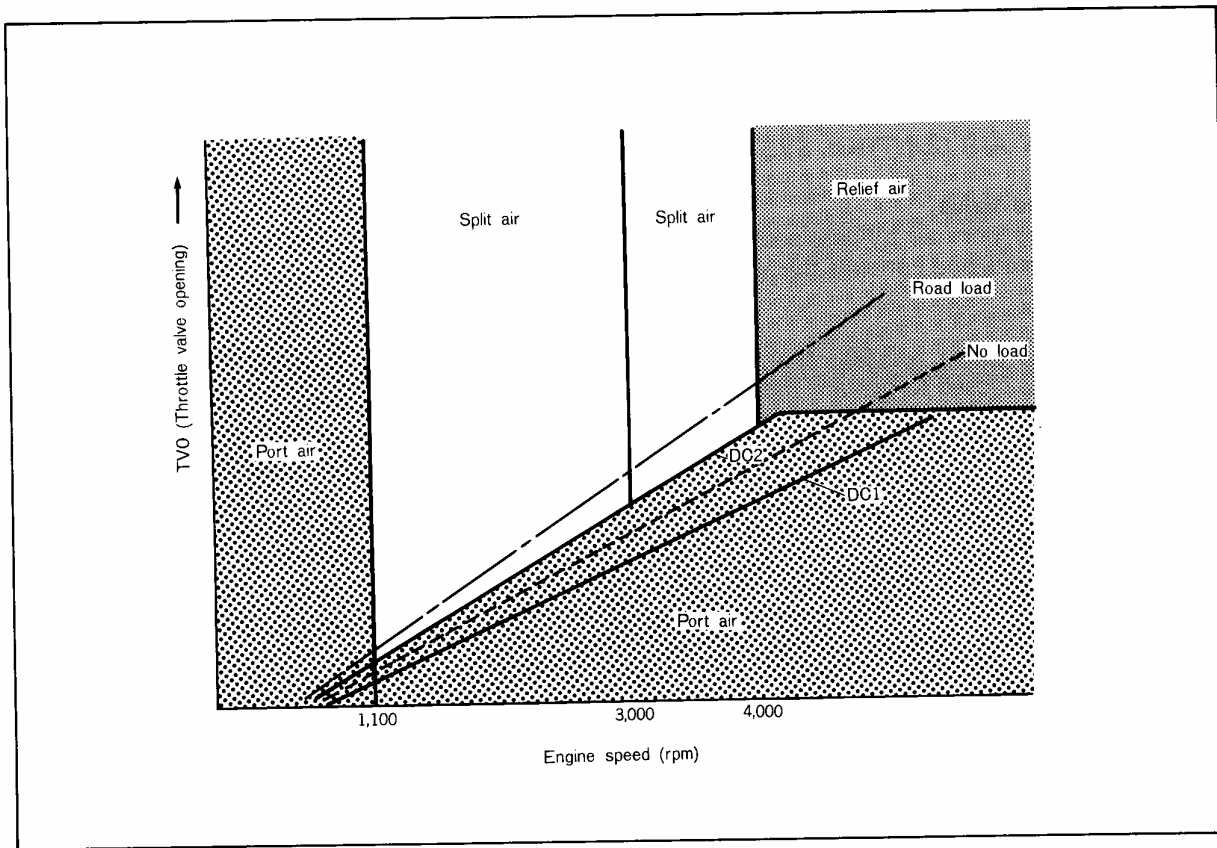

Catalyst Thermo Sensor

The catalyst thermo sensor is newly established behind the main converter. It detects the exhaust gas temperature and transmit the electrical signal to the control unit.

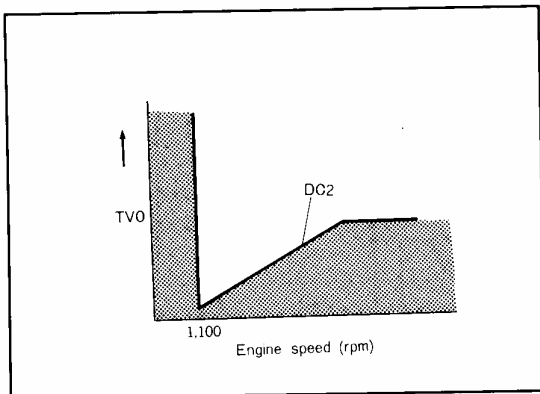
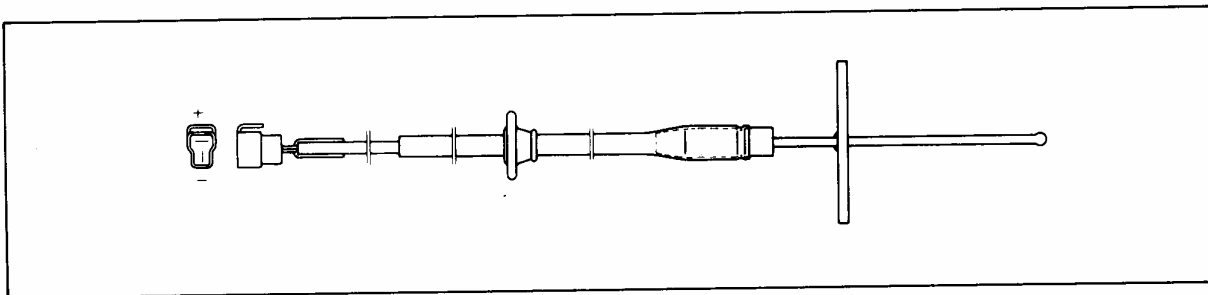

Operation:

When the exhaust gas temperature exceeds a certain temperature, receiving the signal, the control unit makes the relief solenoid valve operate when the engine speed is above 1,100 rpm and decreases the catalyst temperature.

Operating temperature:

- above 770°C (1418°F) . . . M/T
- above 740°C (1364°F) . . . A/T

Delay Valve (for switching valve)

The vacuum delay valve is newly located at the atmosphere passage of switching solenoid valve.

Operation:

Switching into split air from port air is delayed by 0.8 to 1.5 sec. by the operation of delay valve. In the driving condition, such as repeatitious accelerating and decelerating, port air is maintained to promote oxidization of CO and HC which tend to be emitted in this condition.

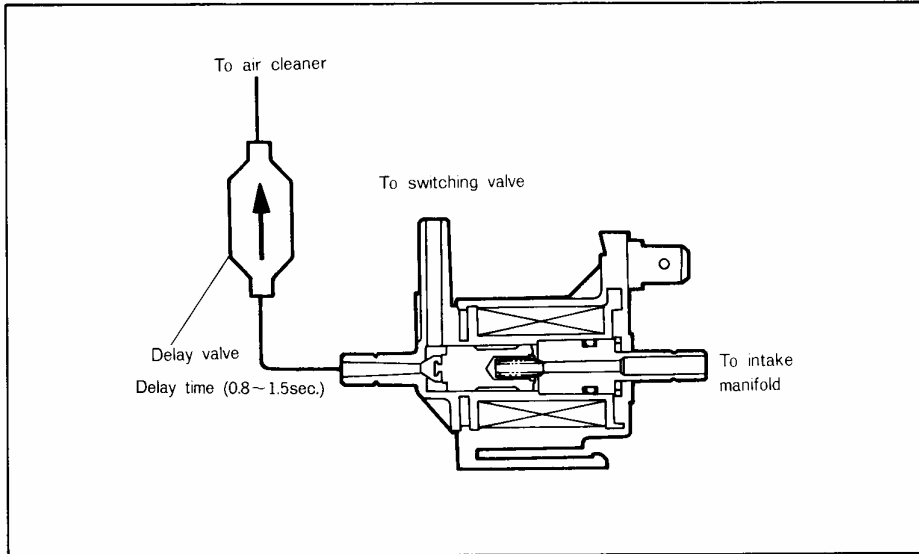

Delay Valve (for relief solenoid valve)

The vacuum delay valve is newly located between relief solenoid valve and relief valve.

Operation:

Switching from relief air into injection air is delayed by 0.8 to 1.5 sec. by the operation of delay valve. When driving the vehicle by repeating accelerating and decelerating above 4,000 rpm, the temperature of catalyst converter increases to prevent the increase in temperature of catalyst converter and after-burn, the relief air condition is maintained even after decelerating from above 4,000 rpm.

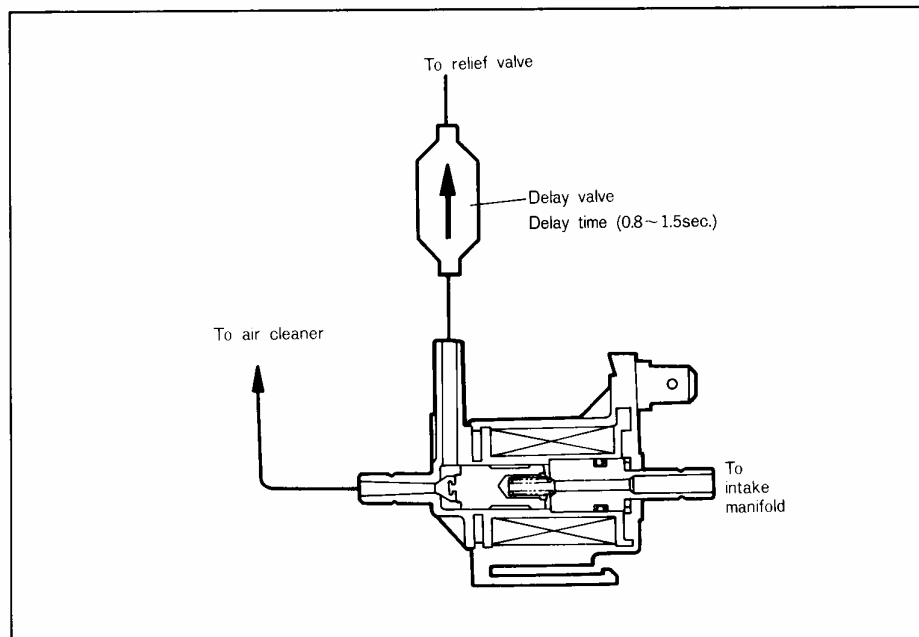

2. MIXTURE CONTROL SYSTEM

Main Air Bleed Control Solenoid Valve

The carburetor is equipped with No. 2 primary main air bleed passage.

The passage is opened and closed by the solenoid valve in accordance with the engine speed or the vehicle speed.

Operation:

When the engine speed is 3,000 ~ 4,000 rpm or the vehicle speed is above 50 MPH, No. 2 primary main air bleed passage is opened to make the A/F ratio lean. Thus, the overheating of catalyst converter is prevented.

Note

The main air bleed control solenoid valve operates at the same time as the port air solenoid valve.

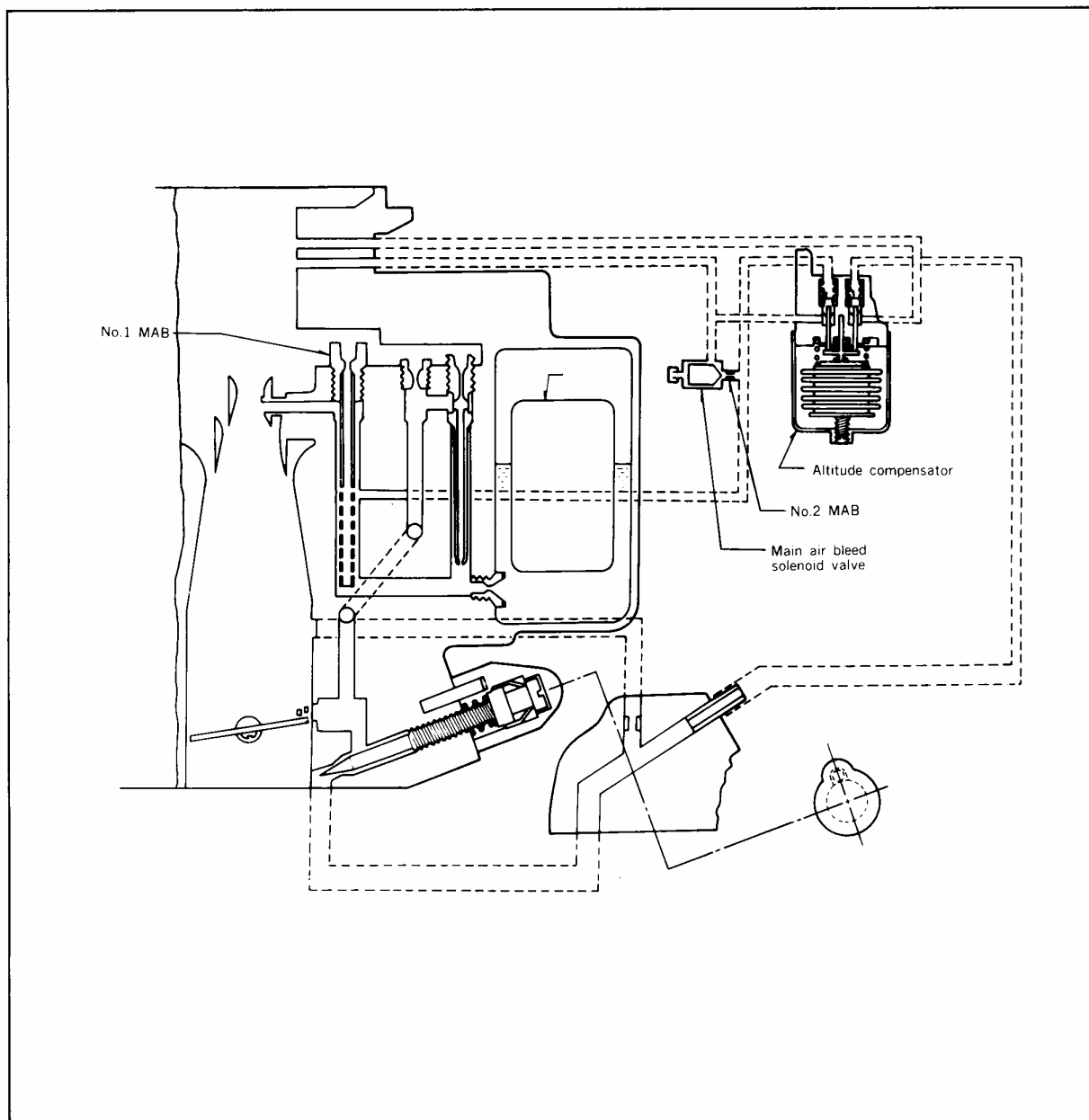

Idle Richer Solenoid Valve (only for M/T)

The idle richer solenoid valve is established to stabilize the emission level below 1,100 rpm at decelerating.

Operation:

The idle richer solenoid valve operated for 30 seconds from the moment when the engine speed decreases to 1,100 rpm or less to make the A/F ratio rich.

Under the following conditions, it does not operate.

- Choke switch Closed
- Vacuum switch Open
- No. 2 temperature switch Open
- Air-con. switch Closed
- Neutral switch Open
- Clutch switch Open

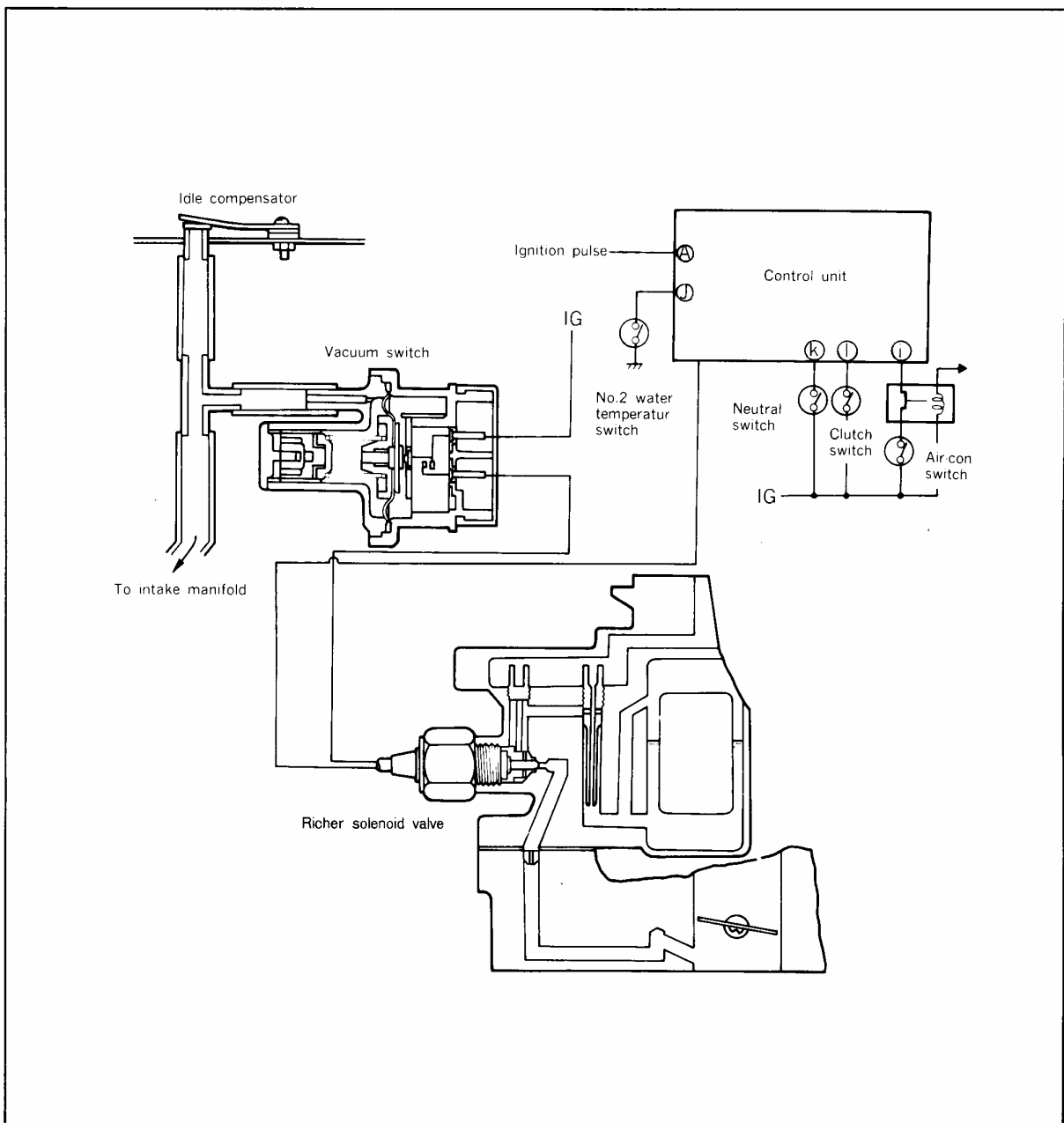

3. CATALYST CONVERTERS

Part Name	1983 Model (12A)	1984 Model (12A & 13B)
No. 1 Pre-monolith	Not Equipped	Equipped
No. 2 Pre-monolith	Equipped	Equipped
3 Bed Monolith (Main)	Not Equipped	Equipped
2 Bed Pellet (Main)	Equipped	Not Equipped
REM	Equipped	Equipped

