

POWER STEERING SYSTEM

OUTLINE	10B- 2	STEERING GEAR	10B-19
STRUCTURAL VIEW	10B- 2	STRUCTURAL VIEW	10B-19
SPECIFICATIONS	10B- 3	STEERING GEAR REMOVAL	10B-20
TROUBLESHOOTING GUIDE	10B- 4	STEERING GEAR	
ON-VEHICLE INSPECTION	10B- 5	DISASSEMBLY	10B-22
FLUID REPLACEMENT	10B- 5	OVERHAUL OF MAIN	
BLEEDING OF POWER STEERING		COMPONENTS	10B-23
SYSTEM	10B- 6	STEERING GEAR BOX	10B-23
POWER STEERING PRESSURE		VALVE HOUSING, WORM SHAFT	
CHECK	10B- 7	AND VALVE	10B-23
STEERING WHEEL EFFORT	10B- 8	PISTON AND BALL NUT	10B-24
LOOSE OR DAMAGED OIL PUMP		STEERING GEAR ASSEMBLY	10B-24
BELT	10B- 8	STEERING GEAR	
OIL PUMP	10B- 9	INSTALLATION	10B-25
STRUCTURAL VIEW	10B- 9	CONTROL VALVE	10B-27
POWER STEERING PUMP		STRUCTURAL VIEW	10B-27
REMOVAL	10B-10	CONTROL VALVE REMOVAL AND	
POWER STEERING PUMP		INSTALLATION	10B-27
DISASSEMBLY	10B-11	CONTROL VALVE TAKING	10B-27
POWER STEERING PUMP		OIL COOLER PIPE	10B-28
INSPECTION	10B-12	OIL COOLER PIPE REMOVAL ...	10B-28
POWER STEERING PUMP		OIL COOLER PIPE ASSEMBLY ...	10B-28
ASSEMBLY	10B-14		
POWER STEERING PUMP			
INSTALLATION	10B-17		

47U10B-001

OUTLINE

STRUCTURAL VIEW

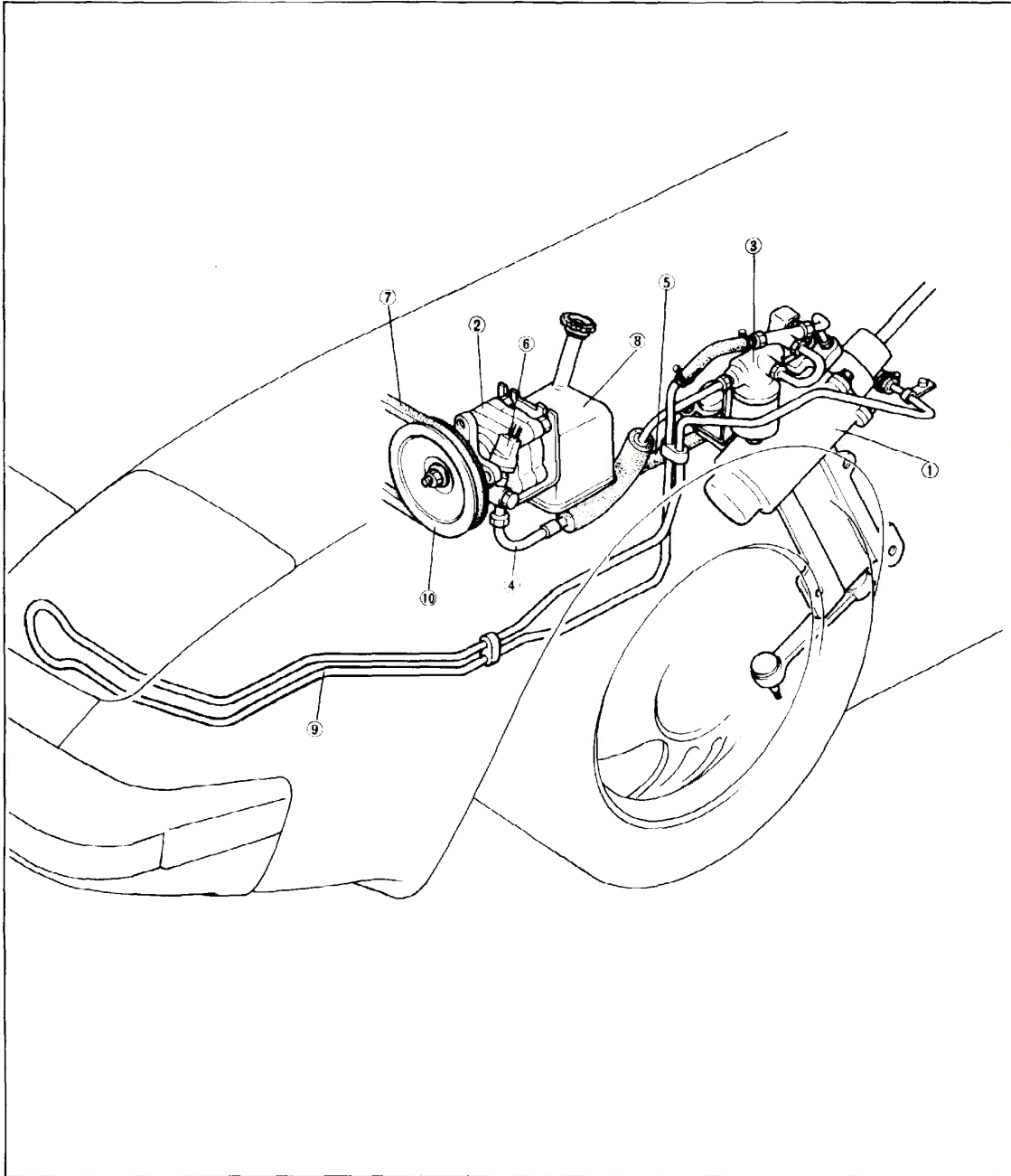

47U10B-002

- | | |
|-----------------|-----------------------|
| 1 Steering gear | 6 Oil pressure switch |
| 2 Oil pump | 7 Drive belt |
| 3 Control valve | 8 Oil tank |
| 4 Pressure hose | 9 Oil cooler pipe |
| 5 Return hose | 10 Pulley |

SPECIFICATIONS

Item		
Steering wheel	Outer diameter	380 mm (14.96 in)
	Lock to lock	3,0
Steering and linkage	Gear type	Ball nut type
	Gear ratio	15.83 : 1
	Shaft type	Regular type
Oil pump	Constant discharge	6.5 ± 0.5 litres/min (1.69 ± 0.13 U.S. gallon, 397 ± 31 cu. in)
	Constant pressure	7000 ⁺⁵⁰⁰ ₋₂₅₀ Kpa (995 ⁺⁷¹ ₋₃₅ lb/in ²)
	Oil pump rpm	600 ~ 6500 rpm
	Oil capacity	0.8 liters (0.21 U.S. gallon, 48.82 cu. in)
	Oil	ATF Type F (M2C33F)

47U10B-003

47U10B-004

Cautions in Handling

Please be careful for the following points because precision components are built in the power steering system.

- (1) Handle so that such foreign matters as water, dust, sand or so may not enter the system. Especially when disconnecting hoses, provide the gears box and/or oil pump with plugs or caps so that such impurities as dust, etc. may not enter them.
- (2) Never use other oil than the specification.
- (3) Always keep the fluid more than the prescribed level.
- (4) Don't keep the steering wheel at the position where it is extremely turned in either direction, during engine revolution for more than 10 seconds.

Caution

If the steering wheel is turned extremely in either direction during engine revolution, no fluid is circulated into the gear box and it is circulated only in the pump, causing the fluid temperature to rise. In this case, turn back the steering wheel a little.

TROUBLESHOOTING GUIDE

Problem	Possible Cause	Remedy	Page
Steering wheel movement is "heavy"	Loose or damaged belt Low fluid level, or air in fluid Crimped or twisted hose Crimped pipe Leakage of fluid	Adjust or replace Supply fluid, or bleed air Repair or replace Replace Repair or replace Replace oil pump	10B-5
Incorrect oil pump hydraulic pressure (requires inspection)	Oil pump hydraulic Maximum pressure (with gauge valve closed) is 6,500 kPa (924 psi) or less Usual pressure (with gauge valve open) is 1,000 kPa (142 psi) or more Maximum pressure with gauge valve open in 6,500 kPa (924 psi) or less when steering wheel is turned all the way to the left or right Insufficient tire pressure Improperly adjusted wheel alignment Linkage ball-joint does not operate smoothly Steering shaft is contacting something	Repair or replace oil line, or replace gear box Replace gear box Adjust Adjust Repair Repair or replace	10B-4
Poor steering wheel return	Incorrect tire pressure Improperly adjusted wheel alignment Linkage ball-joint does not operate smoothly Steering shaft is contacting something	Adjust Adjust Repair or replace Replace	
Required steering effort is uneven	Loose belt Steering shaft is contacting something; loose installation bolt(s) Steering linkage does not operate smoothly Malfunction of steering gear	Adjust Repair or tighten Repair or replace Replace	
Steering wheel pulls to one side	Incorrect tire pressure Improper preload adjustment, or wear of wheel bearing Improperly adjusted wheel alignment Malfunction of steering gear	Adjust Adjust or replace Adjust Replace	
Fluid leakage	Problem at hose coupling Damaged or clogged hose Damaged reserve tank Overflow Malfunction of oil pump Malfunction of gear box	Repair or replace Replace Replace Bleed air, or adjust fluid level Replace Replace	
Abnormal noise	Loose oil pump Loose steering gear Loose oil pump bracket Loose oil pump pulley nut Belt either loose or too tight Air intake Malfunction inside steering gear Malfunction of oil pump Obstruction near steering column or pressure hose Play or looseness of steering linkage	Tighten Tighten Tighten Tighten Adjust Bleed air Replace Replace Repair or replace Tighten, adjust, or replace	

47U10B-005

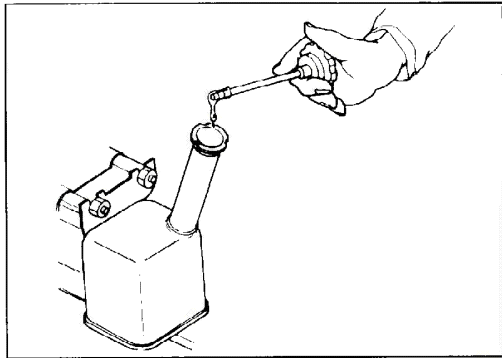

47U10B-006

ON-VEHICLE INSPECTION

Check of power steering fluid.

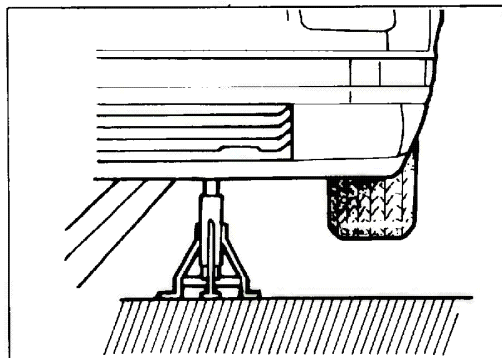

FLUID REPLACEMENT

1. Jack up the front of the vehicle.

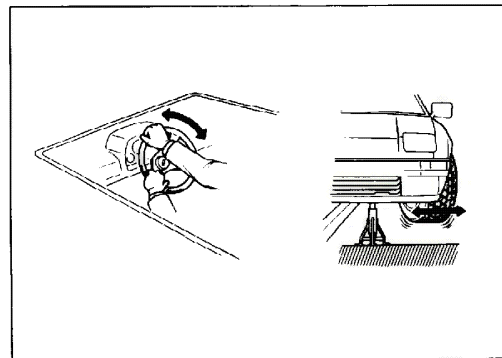

57U10B-007

2. Remove the hose on the pressure side from the pump and receive the outflowing fluid in a receptacle.

3. Remove the fluid from the pump by turning the engine several times by the starter motor. Then, turn the steering wheel clockwise and counter-clockwise to the full to draw off the fluid until no more fluid gets out of the hose.

Caution

Do not start the engine. Do not run the starter for a long time, either.

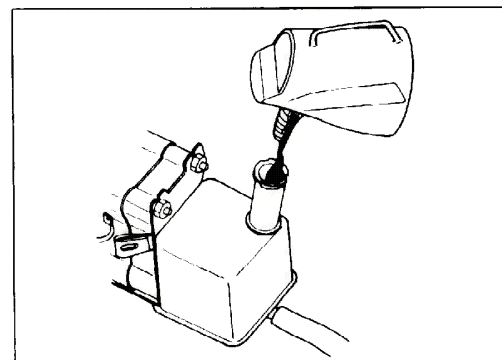

4. Reinstall the hose onto the pump, refill ATF type F(M2C33-F) and air-bleed the steering gear.

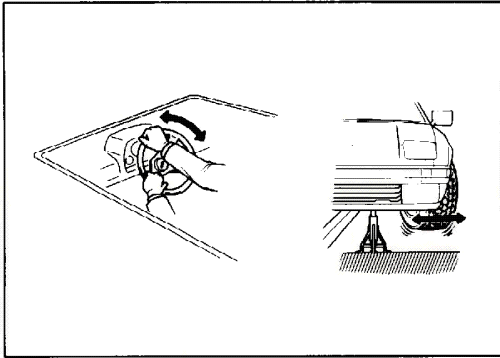

47U10B-008

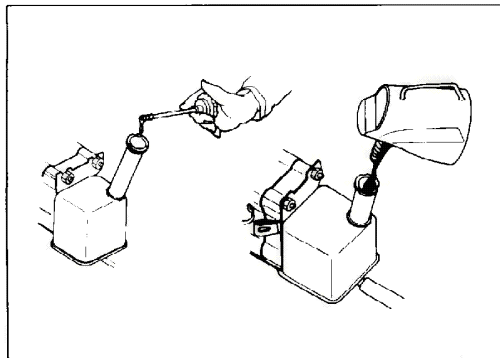
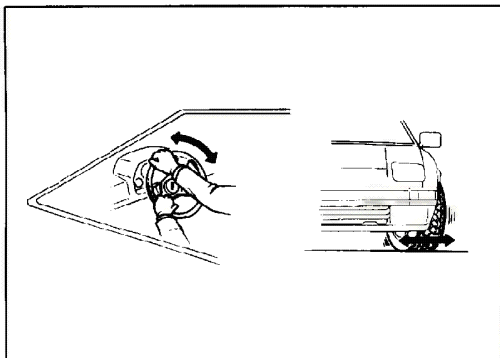

47U10B-009

BLEEDING OF POWER STEERING SYSTEM

Bleeding

1. Jack up the front of the vehicle.
2. Refill the fluid. Since the oil level goes down as the steering wheel is turned from stopper to stopper several times, refill the fluid further.
3. With the steering wheel turned to the full clockwise and counterclockwise respectively, turn the starter while carefully looking at the oil level. Do not start the engine.
4. If the amount of oil is normal, start the engine and counterclockwise to each stopper.
5. Let the vehicle down and turn the steering wheel two to three times to the stopper clockwise and counterclockwise. In this case, a noise may sometimes come out of the oil line, and this is an indication that the air bleeding has not yet been complete.
6. When turning the engine off with the steering wheel placed in the straight forward direction, the oil level in the pump should not go up. If the level goes up too much, the air bleeding performed so far has been incomplete. So, bleed air again as in (5).
7. Check the amount of oil and confirm that there is no fluid leaking.

Caution

If the air bleeding is incomplete, raise the oil temperature to about 50 ~ 80°C (122 ~ 176°F) (the oil temperature will rise by turning the steering wheel clockwise and counterclockwise), stop the engine, and perform the operation as in (5) in five to ten minutes. Air can be completely bled by repeating this operation a couple of times.

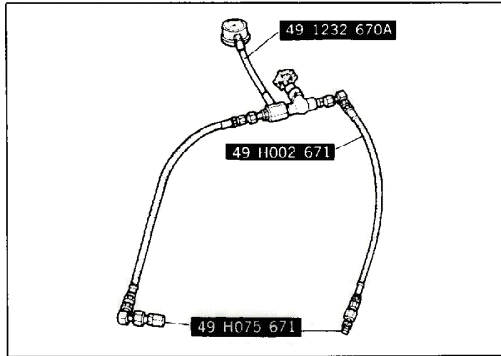

47U10B-010

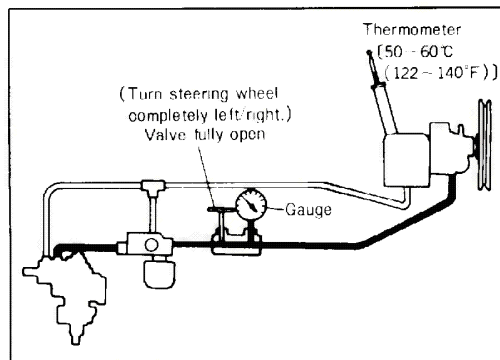
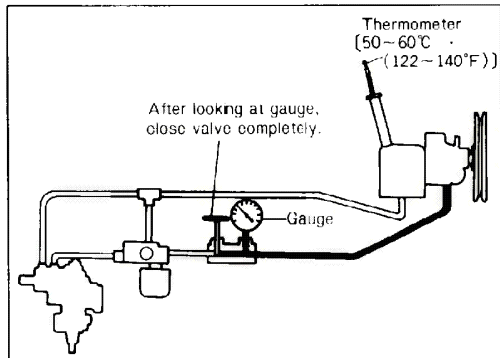
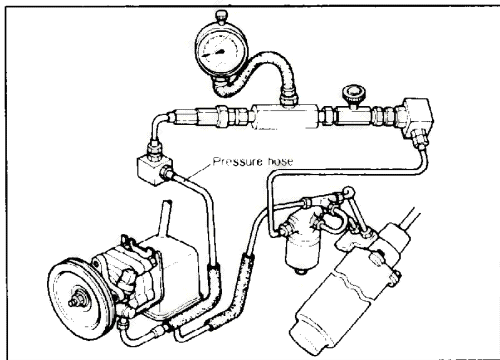

POWER STEERING PRESSURE CHECK

Check in the following order:

1. Disconnect the high-pressure hose of the gear housing side, and attach the **power-steering gauge set** (49 1232 670A) and the **adapters** (49 H002 671 and 49 H075 671 ... 3-piece set).

Cautions

- a) Attach the gauge set so that the valve is at the gear housing side.
- b) Attach the gauge set at a torque of 40 ~ 50 N-m (29 ~ 36 ft-lb).

2. Bleed the air from the system.
3. After opening the gauge valve completely, start the engine and turn the steering wheel so as to raise the fluid temperature to 50 ~ 60°C (122 ~ 140°F).
4. To measure the fluid pressure generated by the oil pump, close the gauge valve completely and increase the engine rpm to 1,000 ~ 1,500 rpm.

Warning

If the valve is left closed for a long time, the fluid temperature will increase excessively and adversely affect the oil pump. Do not, therefore, leave the valve closed for more than 15 seconds.

Caution

If the fluid pressure is less than the specified value, the problem is probably a malfunction of the oil pump. If the oil pump must be replaced, replace it as a complete assembly.

Oil pump fluid-pressure limit

[fluid temperature 50 ~ 60°C (122 ~ 140°F)]:
6,500 kPa (924 psi)

5. To measure the fluid pressure generated at the gear housing, first open the gauge valve completely, increase the engine rpm to 1,000 ~ 1,500 rpm, and then turn the steering wheel all the way to the left and right.

Warning

If the steering wheel is kept in the fully turned position for a long time, the fluid temperature will rise excessively. Do not, therefore, keep the steering wheel in this position for more than 10 seconds.

Caution

If the fluid pressure is less than the specified value, the problem is probably a malfunction of either the oil pump or the gear box. If the oil pump must be replaced, replace it as a complete assembly.

Gear housing fluid-pressure limit
[fluid temperature 50 ~ 60°C (122 ~ 140°F)]:
6,500 kPa (924 psi)

6. After removing the gauge set, tighten the high-pressure hose to the specified torque.
7. Bleed the air from the system. (Refer to page 10B-6.)

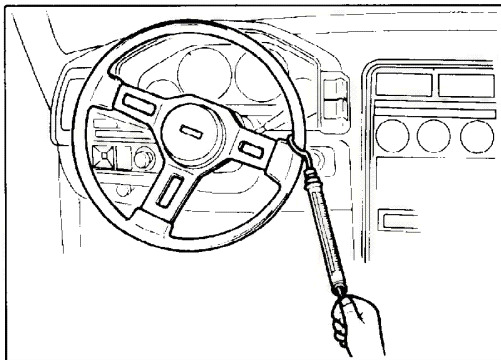

47U10B-011

STEERING WHEEL EFFORT

Check in the following order:

1. With the vehicle on a hard level surface, move the steering wheel to put the wheels in the straight-ahead position.
2. Start the engine and warm the power-steering fluid to 50 ~ 60°C (122 ~ 140°F).

Caution

To warm the fluid, turn the steering wheel in either direction and hold it in that position.

3. Attach a spring gauge to the outer circumference of the steering wheel, and then, starting with the wheels in the straight-ahead position, check the steering effort required to turn the steering wheel to the left and to the right.

Steering wheel effort: 4.0 kg (8.8 lb) or less
[during one turn of the steering wheel]

Caution

If the measured value exceeds the standard value range, check the following points: fluid level air in system, fluid leakage at hose and connections, function of oil pump and gear box, and tire pressure.



47U10B-012

LOOSE OR DAMAGED OIL PUMP BELT

Check the oil pump belt for looseness or damage, and adjust if necessary.

New belt: 10 ~ 12 mm (0.39 ~ 0.47 in)
Used belt: 10 ~ 12 mm (0.39 ~ 0.47 in)

FRONT WHEEL ALIGNMENT

Front wheel alignment (See page 10A-13)

OIL PUMP

Cautions

- a) In order to prevent the entry of dirt dust, etc., disassemble and assemble in a clean, dust-free room.
- b) Before disassembly, plug the pipe installation hole, and then remove all oil and dirt from the outside surfaces of the oil pump.
- c) Before assembly, apply a coating of ATF type F(M2C33-F) to the vanes, rotor, and control valve. Also apply a coating of grease (lithium base, NLGI No. 2) to the lip of the oil seal.

STRUCTURAL VIEW

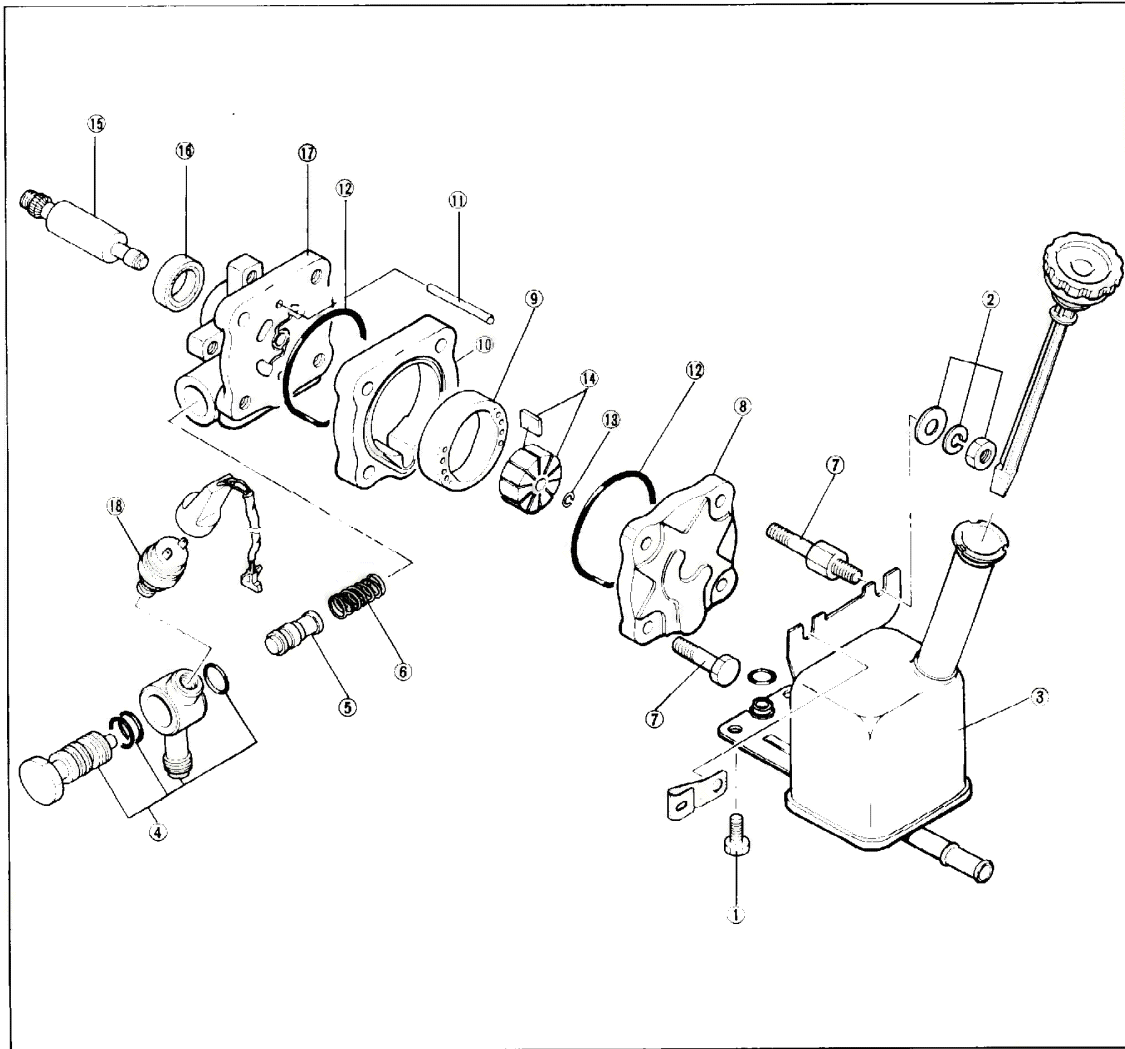

57U10B-013

- | | | |
|----------------------|-------------------|-------------------------|
| 1 Bolts (2) | 7 Bolts (4) | 13 Snap ring |
| 2 Nuts (2) | 8 Body (rear) | 14 Vanes and Rotor |
| 3 Oil tank assembly | 9 Cam ring | 15 Drive shaft |
| 4 Bolt and connector | 10 Cam case | 16 Oil seal |
| 5 Control valve | 11 Knock pins (2) | 17 Body housing (front) |
| 6 Spring | 12 "O" rings (2) | 18 Oil pressure switch |

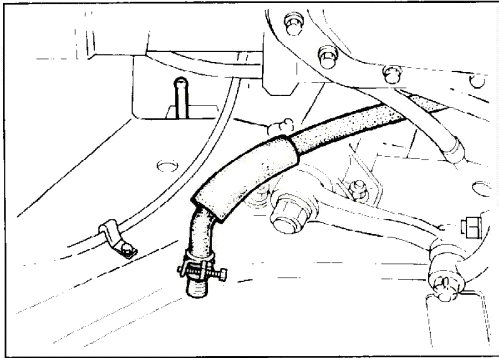

47U10B-014

POWER STEERING PUMP REMOVAL

Remove the following parts in the numerical order.

1. Disconnect return hose from pump.
2. Disconnect pressure tube from pump.

Caution

The power steering fluid will leak out when the return hose and/or the pressure hose are disconnected, so prepare a suitable container for it to flow into.

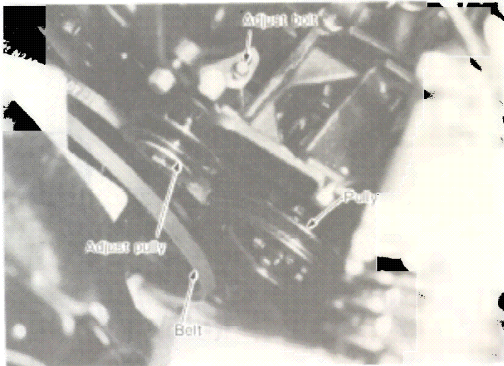

3. Remove drive belt and pulley.
 - a) Push on the drive belt to hold the pulley in place and remove the pulley set nut.
 - b) Loosen the drive belt adjust bolt.
 - c) Remove the drive belt.
 - d) Remove the pulley.

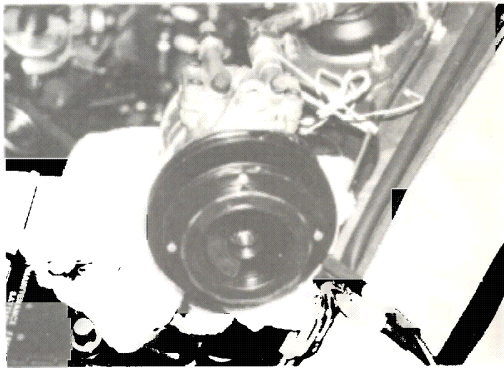

47U10B-015

4. Remove the compressor installation bolts, and then, with the high-pressure and low-pressure hoses still connected to it, secure the compressor as shown in the figure.

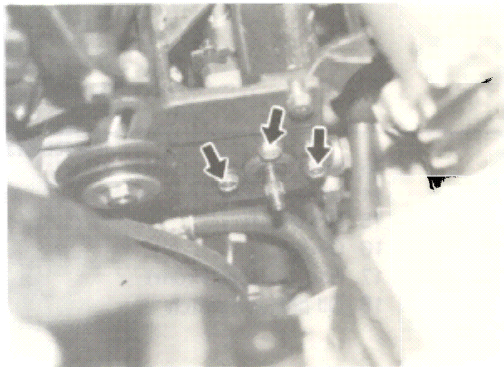

5. Remove the pump mount bolts, and remove the oil pump from the bracket.

POWER STEERING PUMP DISASSEMBLY

1. Mount the pump in a vise with soft jaws.

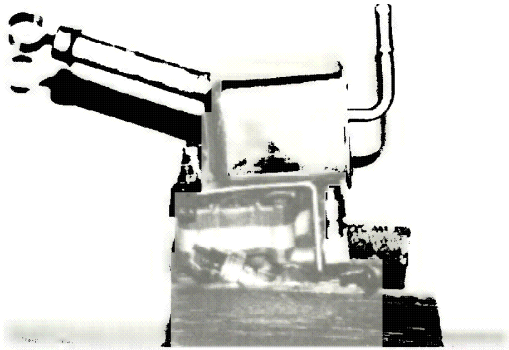

57U10B-016

2. Remove the bolts that attach the suction line connector.
3. Remove the bolts and nuts attaching the tank assembly from the pump and remove the tank assembly, with the suction line connector.

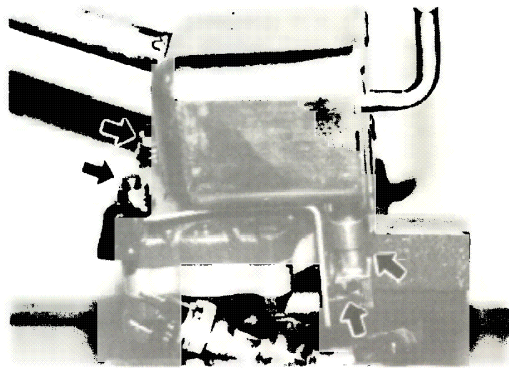

4. Take off the 4 bolts to fix the body and remove the body by tapping it gently with a plastic hammer.

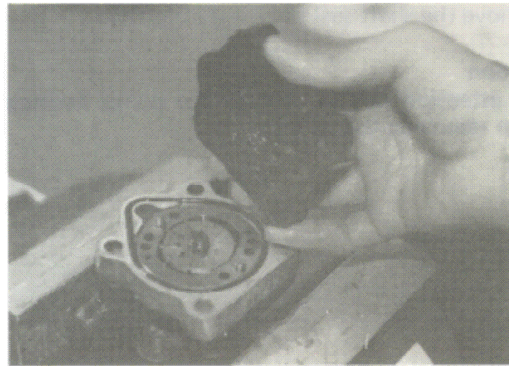

57U10B-017

5. Remove the following parts from the housing in the numerical order.

- (1) Cam case
- (2) Cam ring
- (3) Vanes
- (4) Pins (2)
- (5) Snap ring
- (6) Rotor

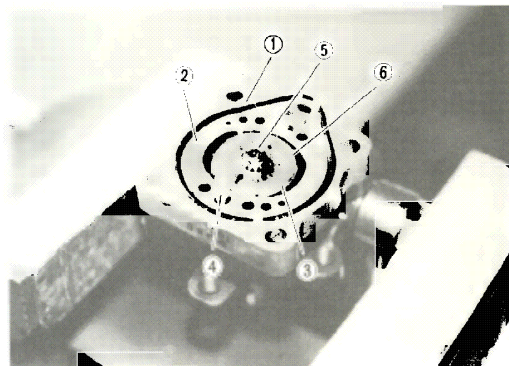

10B OIL PUMP

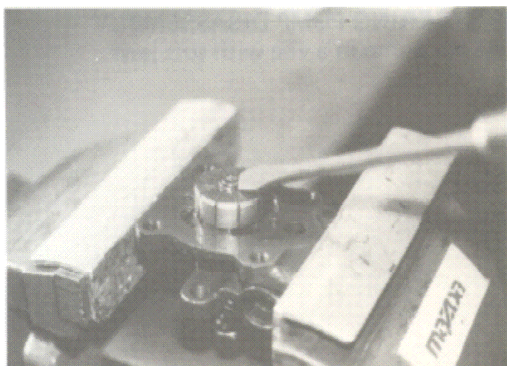

47U10B-018

6. Remove the drive shaft from the housing.



7. Remove the bolt and connector. Remove the flow-control valve and spring from the pump housing. Discard the "O" rings on the bolt.

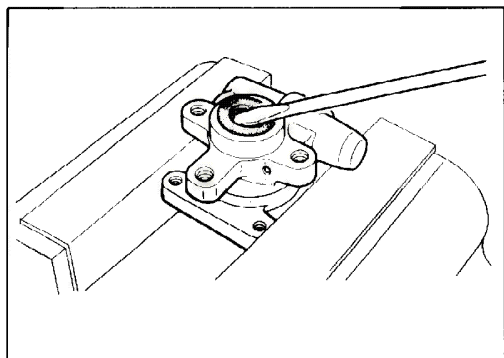

47U10B-019

8. Remove the shaft seal only if it is damaged.

Caution

Pay attention not to damage the pump housing when removing the oil seal.

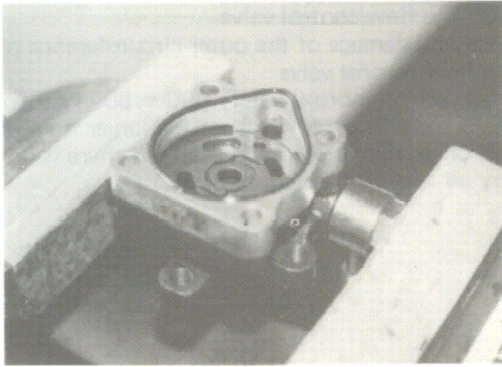

47U10B-020

POWER STEERING PUMP INSPECTION

Clean all parts thoroughly in clean solvent, and then blow it dry with moisture-free compressed air.

Do not use solvent on seals.

1. Inspect the pump housing and shaft.
 - a) Wear and damage of the bush.
 - b) Wear and damage of the bore of the flow-control valve.
 - c) Wear and damage of the shaft.

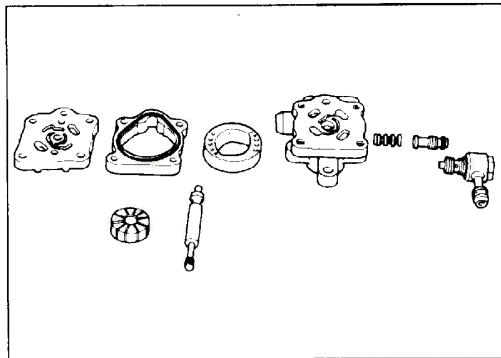

Caution

Exchange the whole body assembly if the bush is defective.

2. Inspect the rotor, and cam ring, burned areas, or scores. These parts must be replaced as an assembly, if damaged.

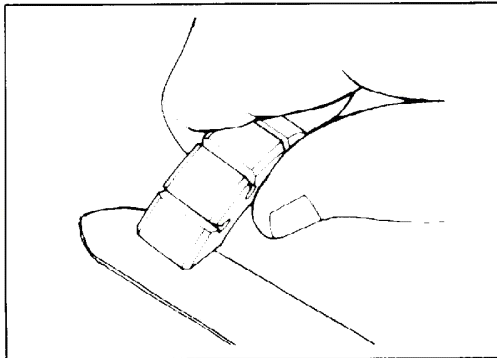

47U10B-021

3. Inspect the vanes for cracks and wear.
Clearance of vanes and rotor grooves
Standard: 0.01 mm (0.0004 in)
Limit: 0.06 mm (0.0024 in)

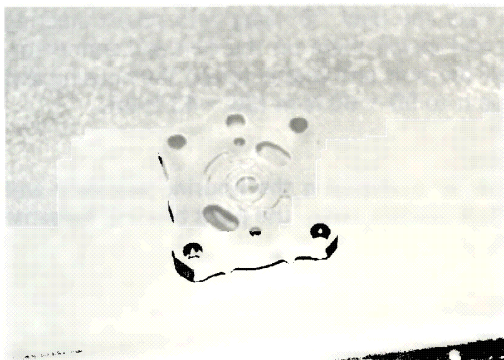

4. Inspect the body for wear or damage.
Wear and damage of the with which the rotor is in contact surface of the body.

10B OIL PUMP

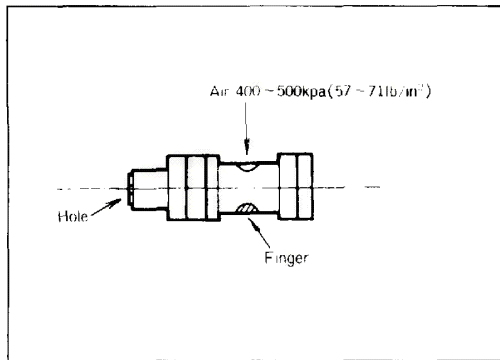

57U10B-022

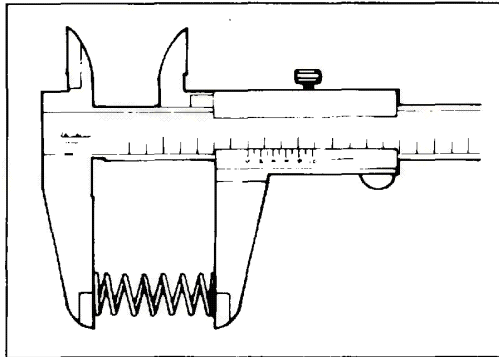

- c) Flow-control spring length
Standard: 25 mm (0.98 in)
Limit: 28.5 mm (1.12 in)

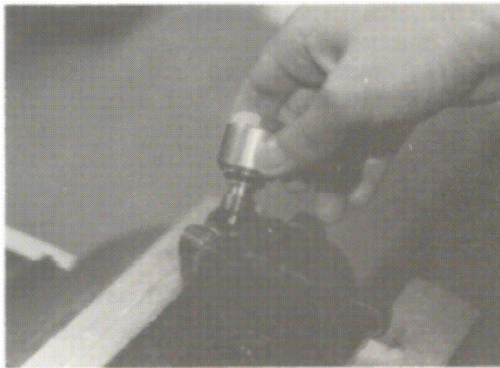

47U10B-023

POWER STEERING PUMP ASSEMBLY

Caution

All of the oil seals and "O" rings should be changed to new ones.

1. Place the flow-control valve spring in its hole and insert the flow-control valve with the filter end toward the flow-control spring side.
2. Lubricate the **new "O" ring** with power steering fluid and install them on the bolt and connector.
3. Install the bolt and connector on the housing and torque it to **50 ~ 60 N·m (36 ~ 43 ft·lb)**.

Caution

In case of exchanging the housing assembly and the flow control valve, use parts bearing the same mark.

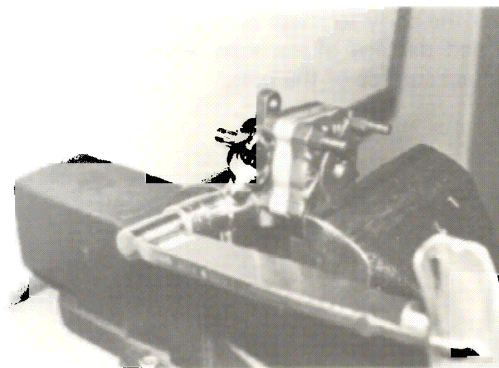

47U10B-024

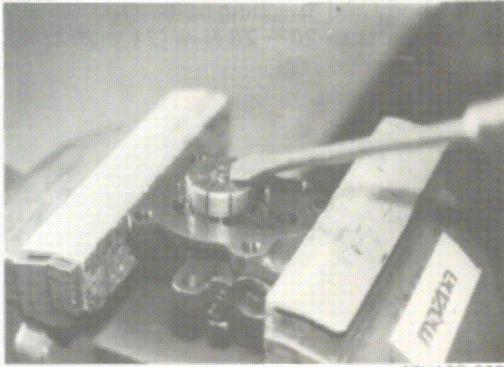

47U10B-025

4. Install the shaft in the housing.
5. Install the side plate, rotor, and snap ring on the shaft.

Cautions

- a) Install the rotor so that the square side mark of the rotor may face to the body (rear).
- b) Use a new snap ring at all times.

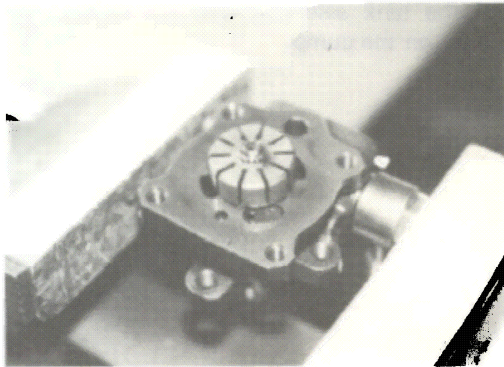

47U10B-026

6. Install the following parts.
 - 1) Cam ring

Cautions

- a) Align the holes of the cam ring to the dowel pins.
- b) Use the rotor and the cam ring bearing the same mark.
- c) Since the cam ring has holes, be sure to align them to the dowel pins.

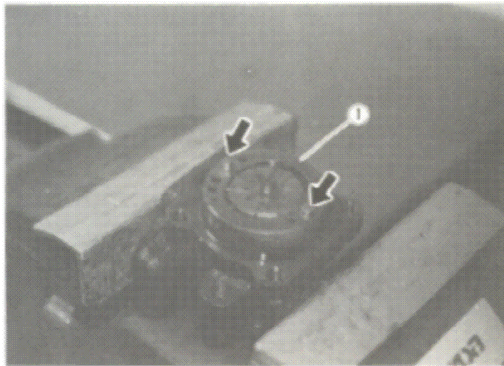

47U10B-027

- 2) Cam case

Caution

Install two "O" rings in the grooves of the cam case.

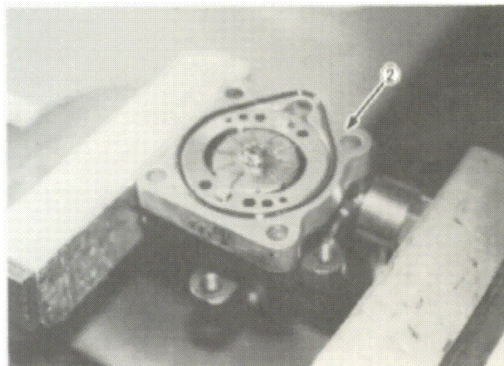

7. Install the vanes in the rotor slots with the rounded edge of the vanes outward. Be sure the vanes slide freely.

Caution

In case of exchanging the cam ring, rotor and vanes, exchange these in a set.

10B OIL PUMP

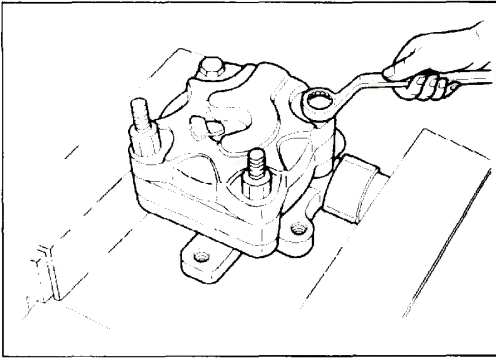

47U10B-028

8. Install the body and attaching bolts.
Torque the bolts to **20 ~ 28 N·m (21 ~ 20 ft·lb)**.

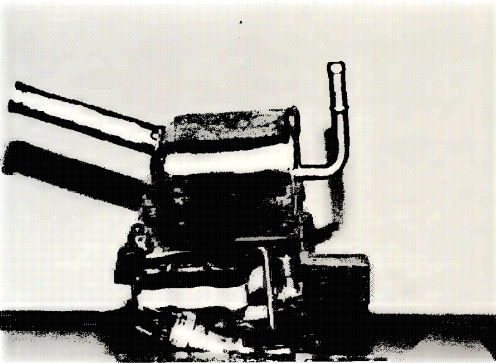

9. Mount the tank assembly with the suction line convector on the pump.

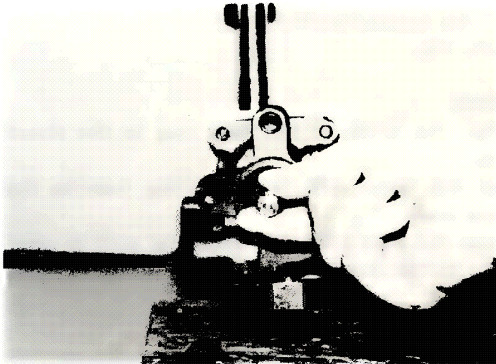

10. Confirm that the shaft rotates smoothly without any catch.

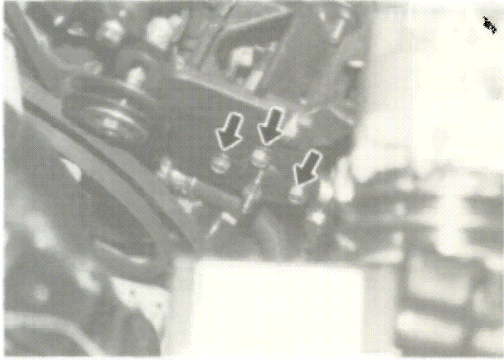

47U10B-029

POWER STEERING PUMP INSTALLATION

1. Install oil pump
 - a) Place the oil pump in position and torque the front mount bolts.

Torque: 32 ~ 47 N-m (23.1 ~ 34.0 ft-lb)

- b) Install the drive belt adjust bolt by hand.

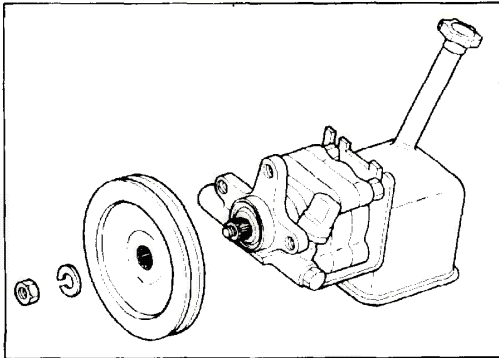

2. Install the pulley onto the pump shaft and tighten the pulley nut to **50 ~ 60 N-m (36 ~ 43 ft-lb)**.

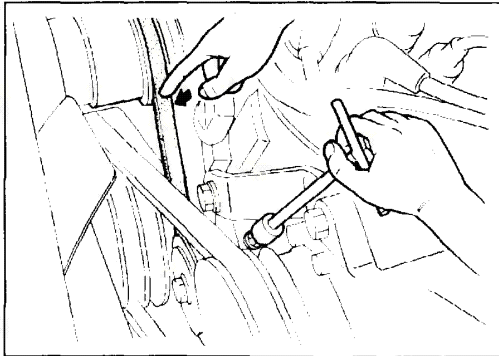

47U10B-030

3. Install pulley and drive belt
 - a) Install the pulley set nut.
 - b) Install the drive belt.

Drive belt tension:

New belt 10 ~ 12 mm (0.39 ~ 0.47 in)

Used belt 10 ~ 12 mm (0.39 ~ 0.47 in)

- c) Push down on the drive belt to hold the pulley in place and torque the pulley set nut.

Torque: 32 ~ 47 N-m (23.1 ~ 34.0 ft-lb)

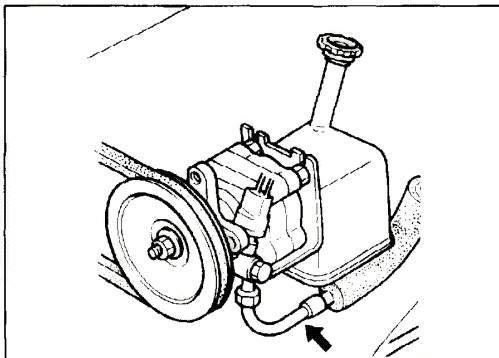

4. Connect pressure tube to oil pump

10B OIL PUMP

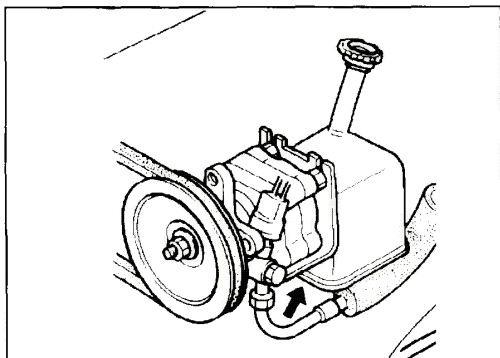

47U10B-031

5. Connect return hose to reservoir tank

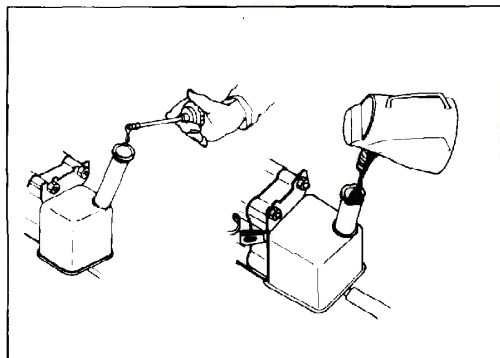

6. Fill reservoir with fluid

Fluid: ATF Type F(M2C33-F)

7. Bleed power steering

8. Check for fluid leaks

STEERING GEAR

Cautions

- a) In order to prevent the entrance of dust, all disassembly and assembly should be done in a dust-proof room.
- b) Before disassembly, plug the openings of all pipe installation fittings, and then remove all external grease and dirt from the gear and linkage.
- c) Before assembly, apply a coating of automatic transmission fluid type F(M2C33-F) to the control valve and piston seal rings.

STRUCTURAL VIEW

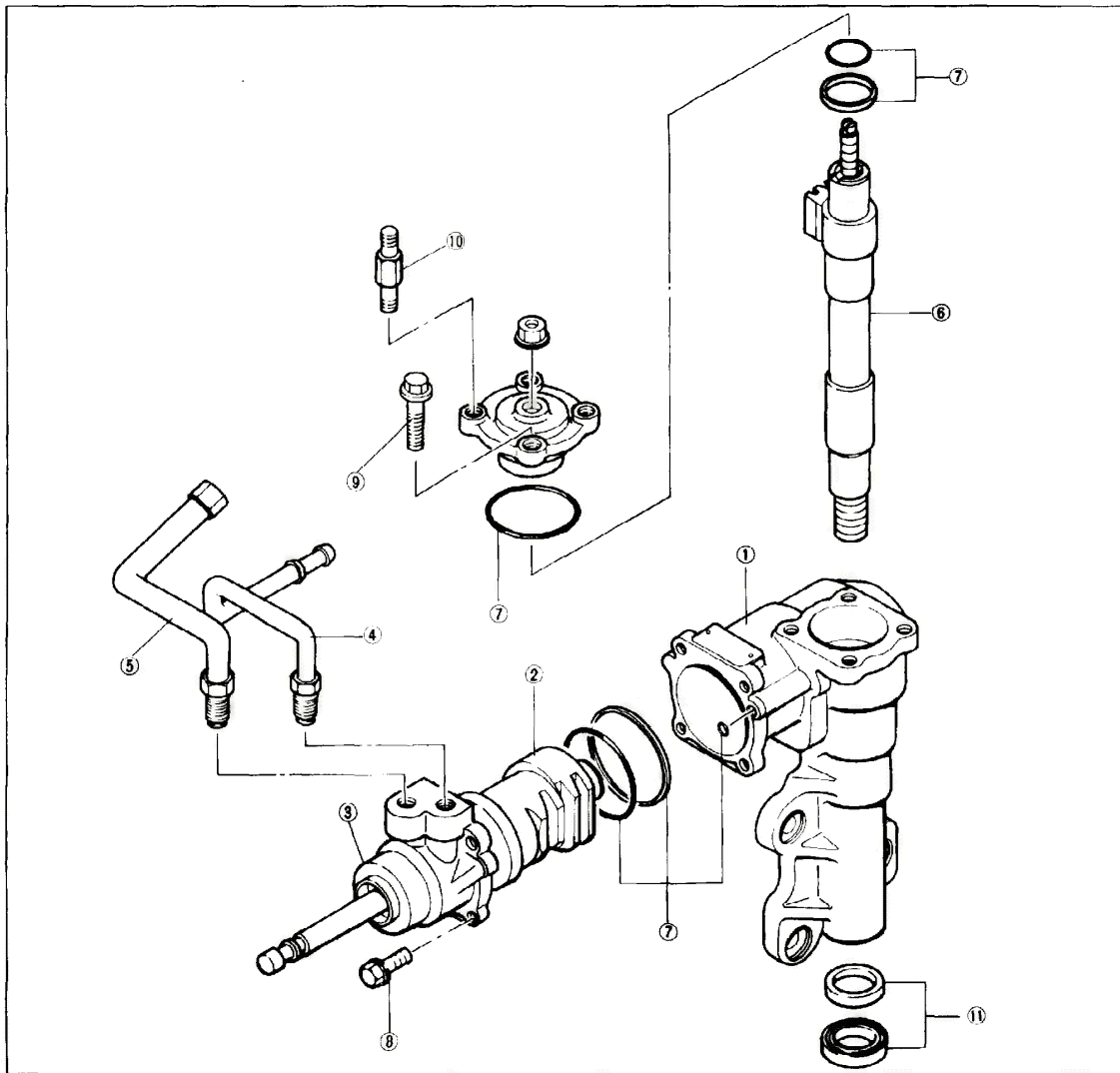

1. Gear housing
2. Valve and piston assembly
3. Side cover assembly
4. Pressure pipe
5. Return pipe

6. Sector shaft assembly
7. Seal kit
8. Bolt with washer (4)
9. Bolt with washer (2)
10. Bolt with washer (2)

11. Oil seal

47U10B-032

10B STEERING GEAR

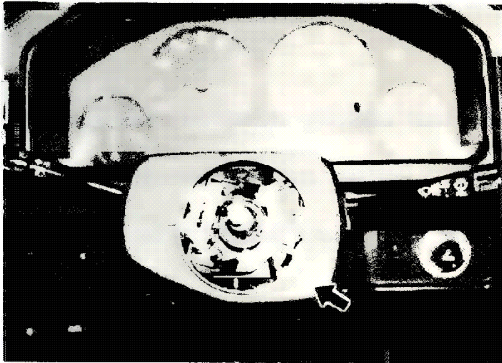

47U10B-033

STEERING GEAR REMOVAL

Remove the steering gear in the numerical order.

1. Battery negative cable
2. Column cover and heater duct



3. Fixing bracket



4. Set plate
5. Steering gear clamp bolt
6. Coupling bolt



Caution

Raise the front end of the vehicle and support it with stands.

7. Center link from pitman arm

Disconnect the center link from pitman arm, use the puller (49 0118 850C).

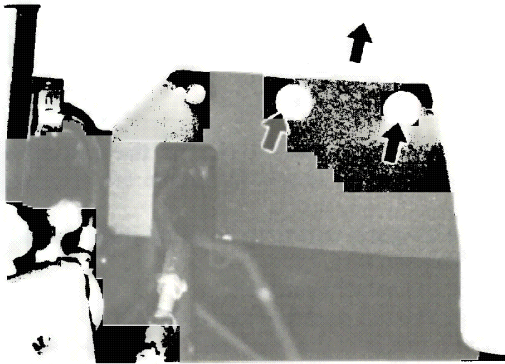

57U10B-034

8. Remove the steering gear bolts (3).



9. Disconnect return line and pressure line.
10. Nuts

STEERING GEAR DISASSEMBLY

1. Steering gear oil (drain)
2. Pitman arm use the puller (49 0223 695E)

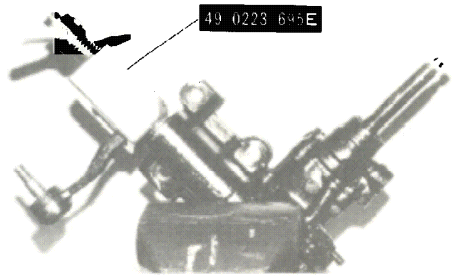

47U10B-035

Cautions

- a) Thoroughly clean the exterior of the unit with solvent. Drain all excess hydraulic oil, if necessary.
- b) Handle all parts carefully to avoid nicks, burrs, scratches and dirt.
- c) Do not use solvent on seals.
- d) Discard the old packing, seal and "O" ring.
- e) Do not remove the ball nut from the worm shaft unless they are defective.

3. Lock nut (loosen)

To center the gear, turn the worm shaft until the identification mark is positioned.

4. Side cover and sector shaft

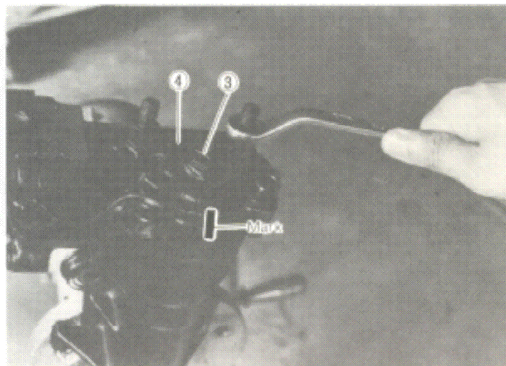

Cautions

- a) When remove the sector shaft, tap the lower end of the sector shaft with a soft-hammer to loosen it, then lift the cover and shaft as an assembly from the steering gear box.
- b) Do not disassemble the sector shaft.

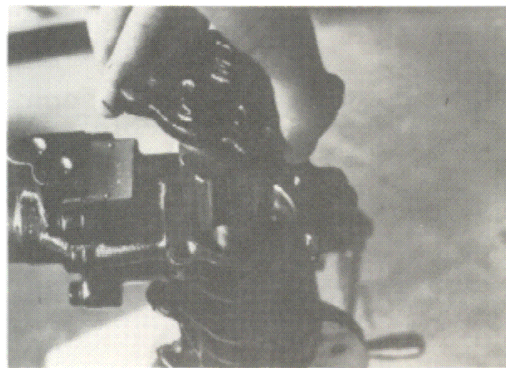

5. Snap ring
6. Valve and piston assembly

If necessary, remove the piston assembly from the valve assembly by rotate the worm shaft counter-clockwise.

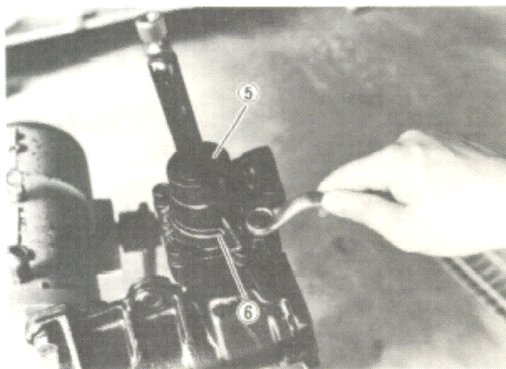

47U10B-036

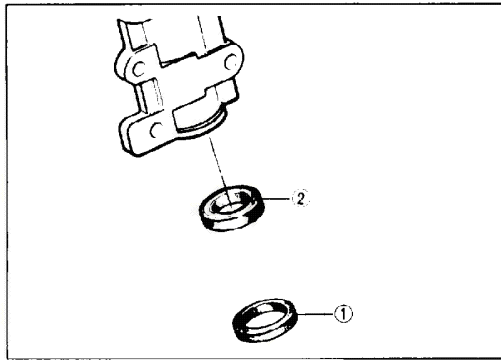

47U10B-037

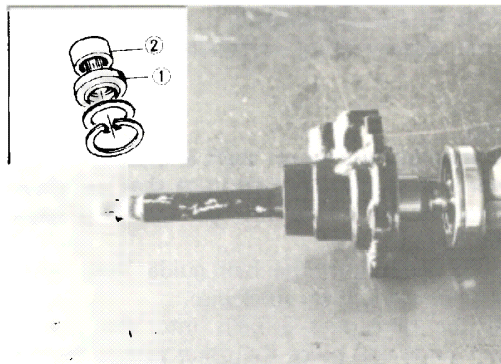
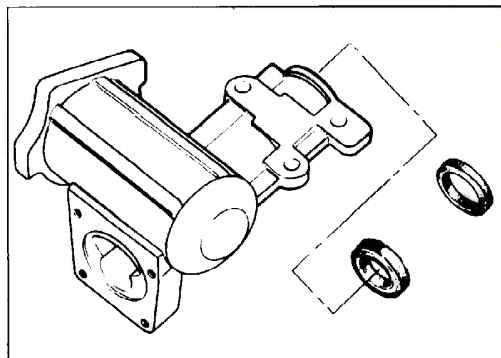

47U10B-038

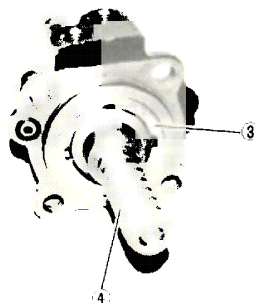

OVERHAUL OF MAIN COMPONENTS

STEERING GEAR BOX

Disassembly

Disassemble the parts in the numerical order.

1. Lower seal
2. Upper seal

Checking

1. Clean the steering gear box thoroughly in clean solvent, and then blow it dry with moisture-free compressed air.
2. Inspect the steering gear box for scores in the area where the ball nut and seal moves.

Assembly

Follow the disassembly procedure in the reverse order.

Caution

The upper seal should be fitted with the lip facing inward, while the lower seal should be fitted with the lip facing out.

VALVE HOUSING, WORM SHAFT AND VALVE

Disassembly

Disassemble the parts in the numerical order.

1. Oil seal

Caution

Do not remove the needle bearing from valve housing unless the bearing is defective.

2. Bearing.

3. Sleeve
4. Worm shaft assembly
5. "O" rings

10B STEERING GEAR

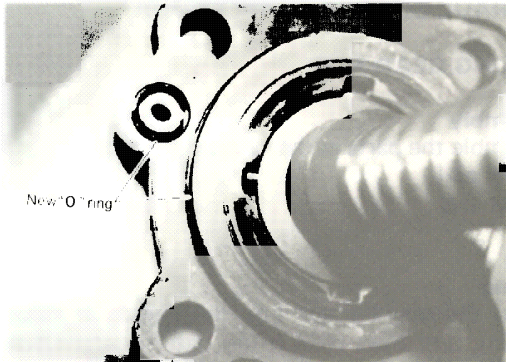

47U10B-039

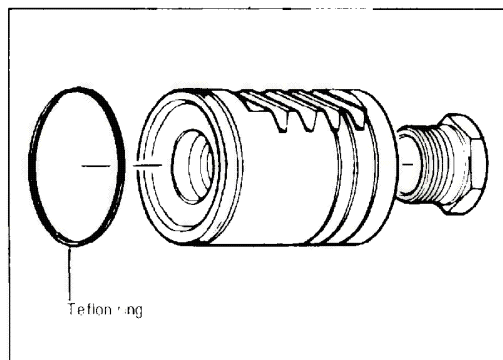

47U10B-040

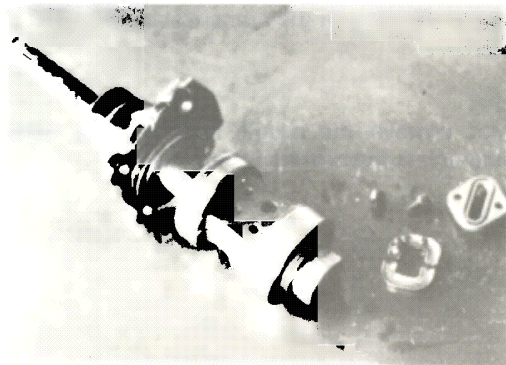

47U10B-041

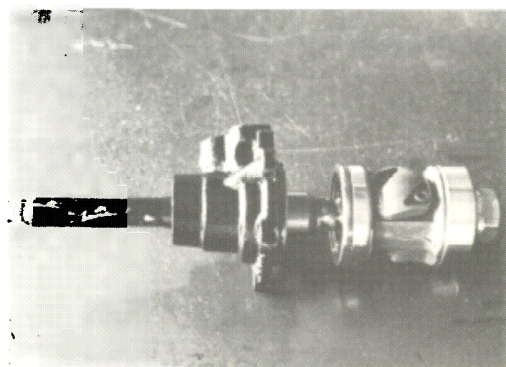

Assembly

Follow the disassembly procedure in the reverse order.

Cautions

- Use the new Teflon ring, "O" ring and seal.
- Dip all parts in power steering fluid before assembling.
- Install the dust seal with the rubber side facing out and oil seal with the lip facing inward on the valve housing.

PISTON AND BALL NUT

Replacement

- Remove and discard the Teflon ring and the "O" ring from the piston and ball nut.
- Dip a new "O" ring in gear lubricant and install it on the piston and ball nut.
- Install a new Teflon ring on the piston and ball nut. Do not stretch the ring any more than necessary.

Caution

If the piston is defective, it should be replaced with the valve and piston assembly.

STEERING GEAR ASSEMBLY

Follow the disassembling procedures in the reverse order.

Caution

When assembly the worm shaft and piston, insert the worm shaft into the piston so that the about two grooves are visible between the valve housing and ball nut.

Insert 22 balls into the ball guide hole, while turning the worm shaft clockwise.

Install the remaining 8 balls into one side of the ball guide and place the other side of the ball guide on it, then install the ball guide assembly to piston.

Install the dark colored balls and polished ball alternately.

Caution

Once the balls are inserted, do not rotate the worm shaft or piston more than necessary, or the balls will fall out of the circuit.

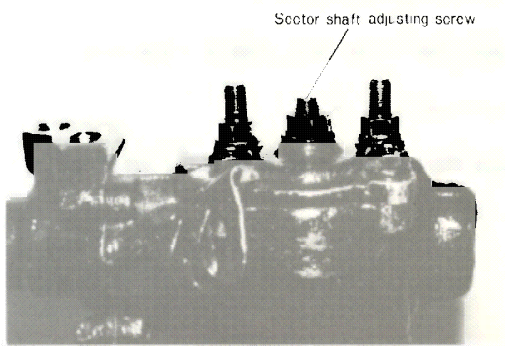

47U10B-042

Worm shaft preload must be measured using **attachment** (49 180 510B) and a spring scale, before installing the sector shaft.

Torque: 0.25 ~ 0.5 N-m (0.18 ~ 0.36 ft-lb)

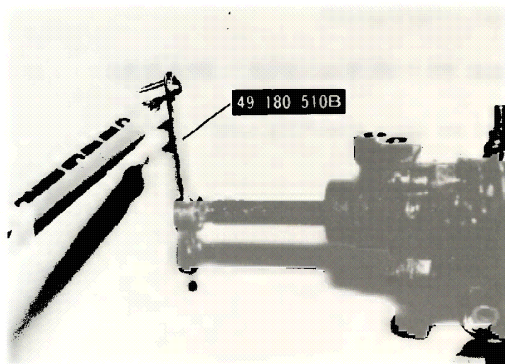

Turn the sector shaft adjusting screws so that the maximum preload is within 0.5 ~ 0.9 N-m (4.3 ~ 7.7 in-lb).

Specified tightening torque:

Valve and piston assembly to Gear box:
38 ~ 50 N-m (28 ~ 36 ft-lb)

Side cover to Gear box:
27.6 ~ 41.5 N-m (20 ~ 30 ft-lb)

Sector shaft adjust screw lock nut:
3.5 ~ 4.8 N-m (2.5 ~ 3.5 ft-lb)

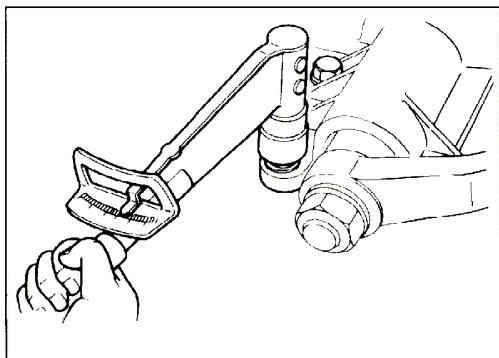

47U10B-043

STEERING GEAR INSTALLATION

1. Install gear housing

Torque: 45 ~ 57 N-m (33 ~ 41 ft-lb)

10B STEERING GEAR

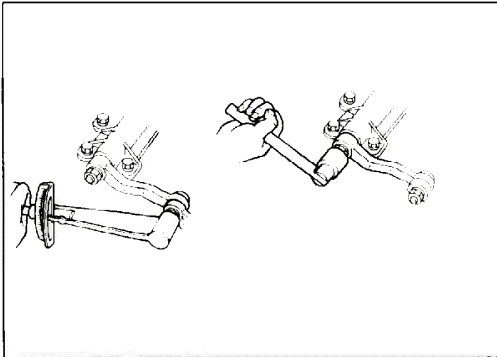

47U10B-044

2. Tighten pitman arm nut

Torque: 150 ~ 180 N-m (108.5 ~ 130 ft-lb)

3. Connect ball joint nut

Torque the nut: 30 ~ 45 N-m (22 ~ 33 ft-lb)

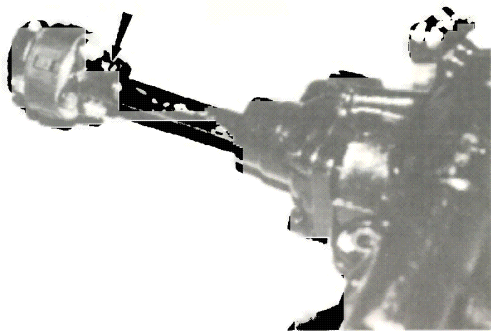

4. Tighten coupling bolt

Torque: 44 ~ 55 N-m (31.8 ~ 39.8 ft-lb)

Tighten set plate attaching nuts

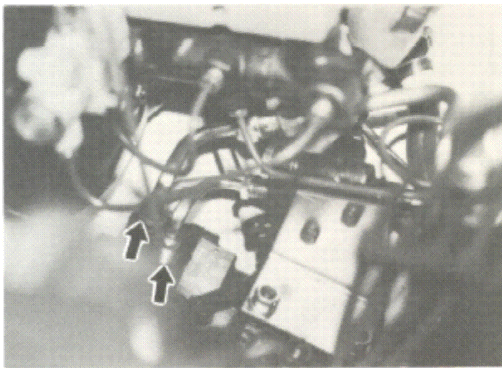

5. Install pressure and return lines

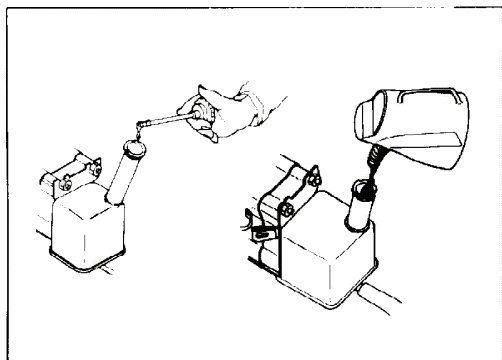

6. Fill reservoir with fluid

Fluid: ATF type F(M2C33F)

7. Bleed system and perform pressure check. (See page 10B-6.)

CONTROL VALVE

STRUCTURAL VIEW

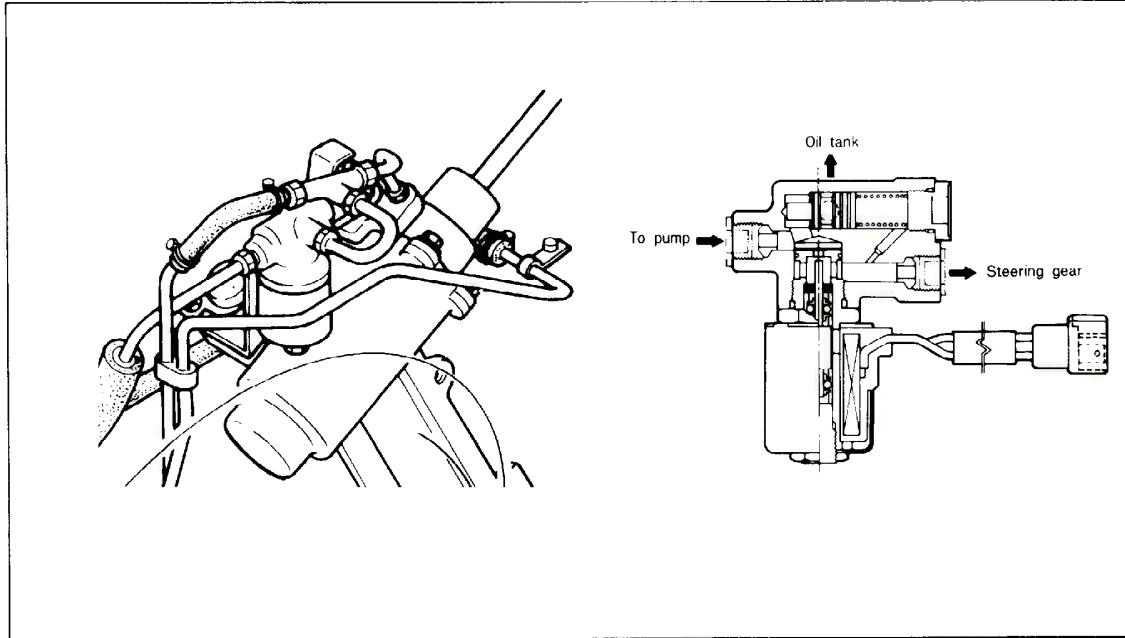

47U10B-045

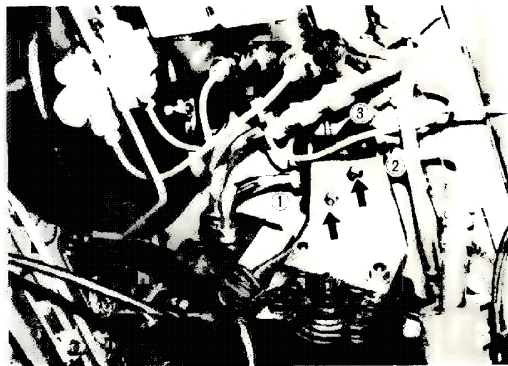

CONTROL VALVE REMOVAL AND INSTALLATION

1. Loosen the pipe on the control valve
2. Remove the bolts (2)
3. Remove the connector

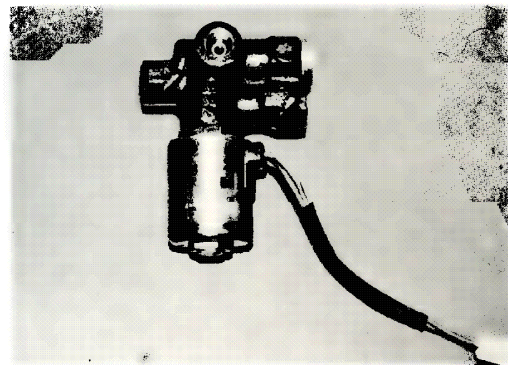

If either of the control valve is not functioning properly, check the electric signal (**refer to Group 15**); if the malfunction is in the control valve, replace it.

10B OIL COOLER PIPE

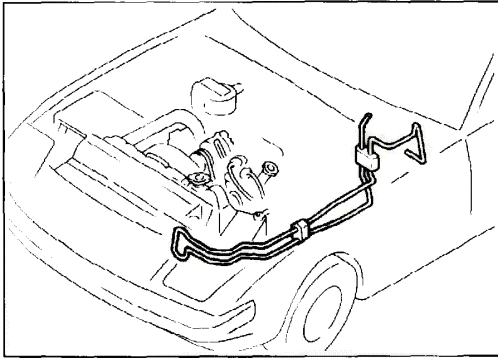

47U10B-046

OIL COOLER PIPE

OIL COOLER PIPE REMOVAL

1. Disconnect the harness clamp.
2. Disconnect the hose (2)
(install a plug)
3. Remove the bolts.
4. Remove the oil cooler pipe.

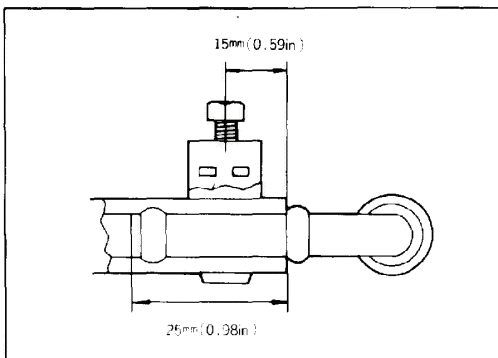

OIL COOLER PIPE ASSEMBLY

1. Connect the hose.
2. Install the bolts.