

RX-7

Factory Service Material

This manual can be downloaded for free from
<http://members.xoom.com/twinturboteddy/fsm/rx7.htm>

Or you can donate \$10 to diepat@earthlink.net through **paypal.com** and a gift CD with all manuals and resources I carry will be sent to you.

This includes

- 1993 Factory Service Manual
- 1988 Factory Service Manual
- 1995 Printed Microfiche of all parts
- 1989 Printed Microfiche of all parts*
- 1990 Printed Microfiche of all parts*
- 1986 Printed Microfiche of all parts*
- 1987 Printed Microfiche of all parts*
- 1988 Printed Microfiche of all parts*

The \$10 donation is used to offset the tremendous amount of time it takes to make everything available.



* These works are currently in process and may or not be readily available upon request. They will be hosted on the same link above and for download

COOLING SYSTEM

OUTLINE	3- 2
STRUCTURAL VIEW	3- 2
COOLANT FLOW CHART	3- 3
SPECIFICATIONS	3- 4
TROUBLESHOOTING GUIDE	3- 4
INSPECTION	3- 5
COOLANT	3- 5
COOLANT CIRCUIT	3- 6
COOLANT FILLER CAP	3- 7
COOLING FAN BELT	3- 7
THERMO-MODULATED FAN	3- 7
WATER PUMP	3- 8
REMOVAL AND INSTALLATION	3- 8
DISASSEMBLY AND ASSEMBLY	3-10
INSPECTION	3-12
THERMOSTAT	3-13
REMOVAL	3-13
INSPECTION	3-13
INSTALLATION	3-13
RADIATOR	3-14
REMOVAL AND INSTALLATION	3-14
INSPECTION	3-14
ELECTRICAL FAN	3-15
SYSTEM CIRCUIT	3-15
INSPECTION	3-15

3 OUTLINE

OUTLINE

OUTLINE OF CONSTRUCTION

A new radiator cap including a pressure valve is added to the radiator tank for improved air-bleeding.

STRUCTURAL VIEW

87U03X-001

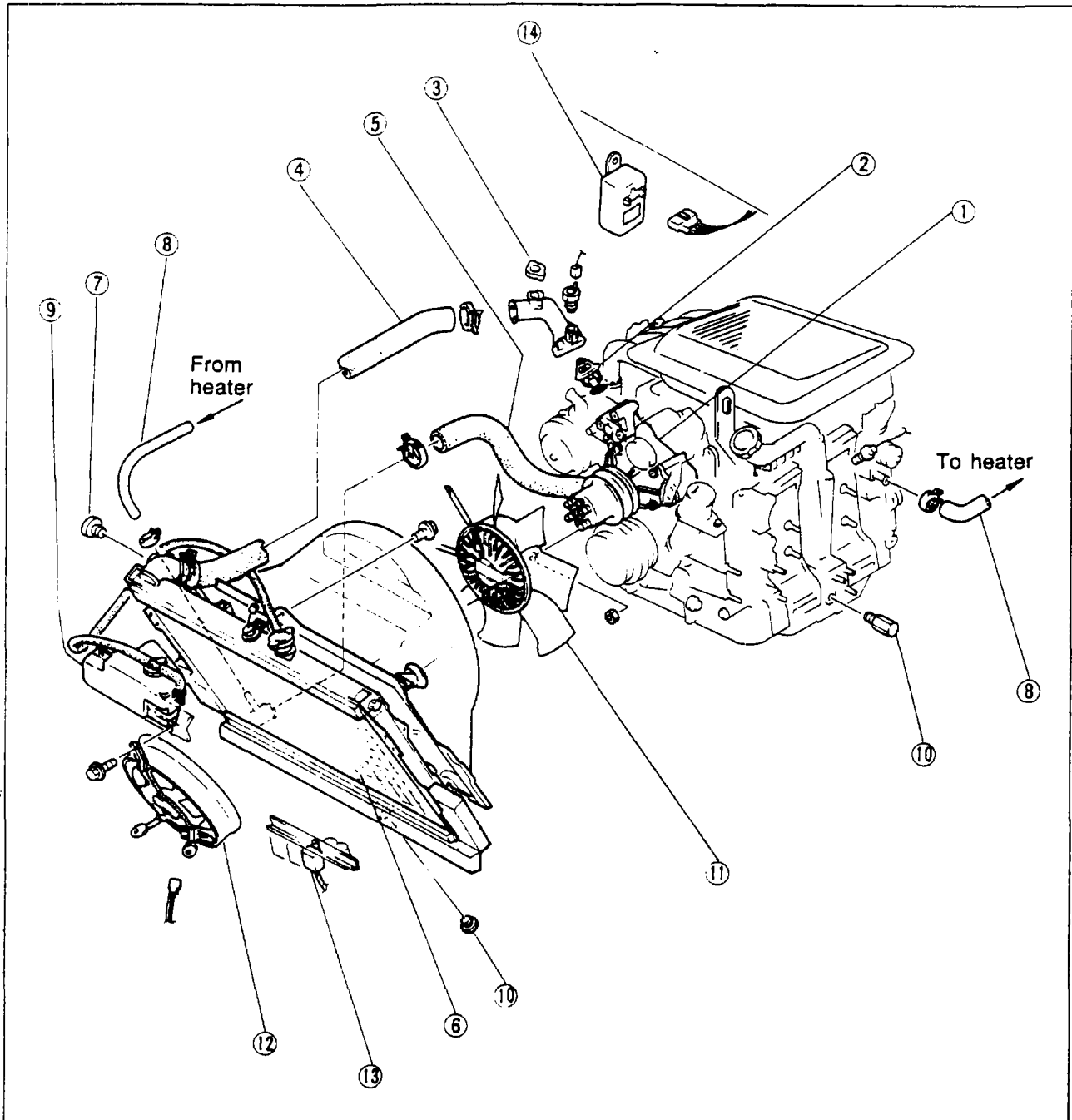

87U03X-003

- | | |
|------------------------|--------------------------|
| 1. Water pump | 8. Heater hose |
| 2. Thermostat | 9. Coolant reservoir |
| 3. Coolant filler cap | 10. Drain plugs |
| 4. Upper radiator hose | 11. Thermo-modulated fan |
| 5. Lower radiator hose | 12. Electrical fan |
| 6. Radiator | 13. Fan relay |
| 7. Air bleeder plug | 14. Fan control unit |

COOLANT FLOW CHART

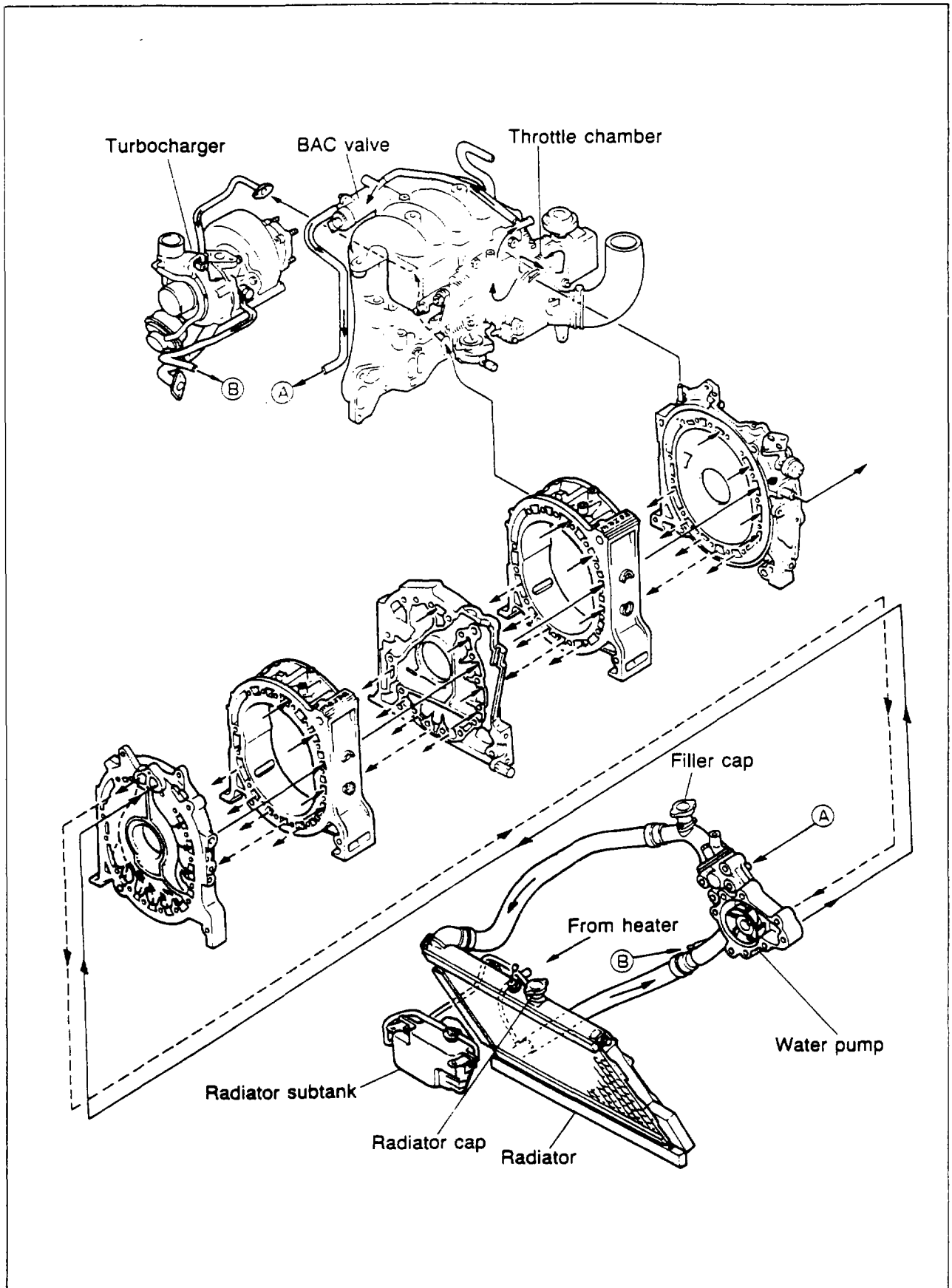

SPECIFICATIONS

Items		Engine models	Turbo	Non-Turbo
Cooling method			Water cooled, forced circulation	
Coolant capacity	With heater	liters (US qt, Imp qt)	8.7 (9.2, 7.7)	7.3 (7.7, 6.4)
Water pump	Type		Centrifugal	
	Pulley ratio (speed)		1.1:23	
Thermostat	Type		Wax, bottom bypass	
	Opening temperature	°C (°F)	80.5—83.5 (197—183)	
	Full open temperature	°C (°F)	95 (203)	
	Full open lift	mm (in)	8 (0.315) or more	
Radiator	Type		Corrugated fin	
Filler cap	Relief pressure	kPa (kg/cm ² , psi)	73—103 (0.75—1.05, 107—14.9)	
Cooling fan	Type		Thermo-modulated	
	Number of blades		8	
	Outer diameter	mm (in)	390 (15.35)	
Electrical fan	Type		Electrical	
	Capacity	W	90	
	Number of blades		5	
	Outer diameter	mm (in)	255 (10.04)	

77U03X-003

TROUBLESHOOTING GUIDE

Problem	Possible Cause	Remedy	Page
Coolant leakage	Damaged radiator core seam	Replace	3—14
	Damaged or loose radiator hose or heater hose	Repair or replace	3—6
	Damaged or loose water temperature switch	Repair or replace	—
	Malfunction of water pump seal	Replace	3—8
	Damaged or loose thermostat cover or water pump case	Repair or replace	3—13
	Malfunction of gasket	Replace	—
	Damaged or loose tension bolt	Refer to Section 11	
	Damaged sealing rubber	Refer to Section 11	
	Damaged side housing	Refer to Section 11	
	Damaged rotor housing	Refer to Section 11	
Corrosion	Impurities in coolant	Replace	3—5
Overheating	Water passage clogged	Clean	3—5
	Thermostat malfunction	Replace	3—13
	Radiator fins clogged	Clean	3—14
	Water pump malfunction	Repair or replace	3—8
	Insufficient coolant	Add	3—5
	Loose or broken fan belt	Adjust or replace	3—7
	Thermo-modulated fan malfunction	Replace	3—7
	Electrical fan malfunction (A/T)	Repair or replace	3—15
Coolant filler cap malfunction	Replace	3—7	

67U03X-006

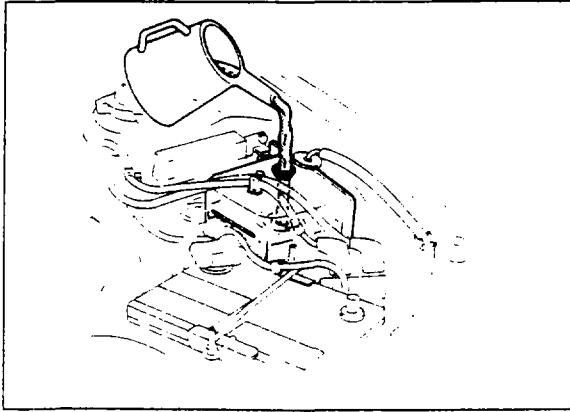

67U03X-007

INSPECTION

COOLANT Coolant Level

While the coolant is cold, the coolant level should be at the coolant filler port. Bleed air from the air bleeder hole on the radiator and add coolant if necessary. The level in the coolant reservoir should be between the FULL and LOW marks. Add coolant if the level is low.

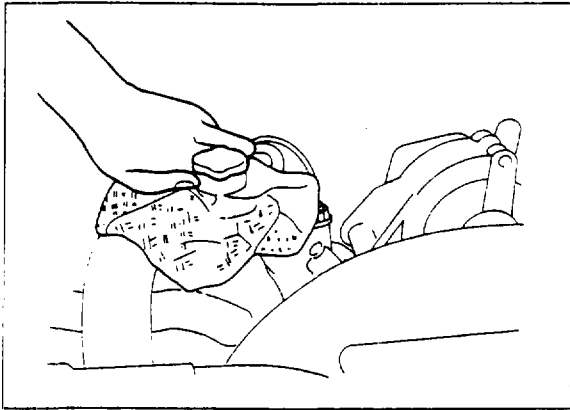

67U03X-008

Warning

Never remove the coolant filler cap while the engine is hot.

Wrap a thick cloth around the cap and carefully remove the cap.

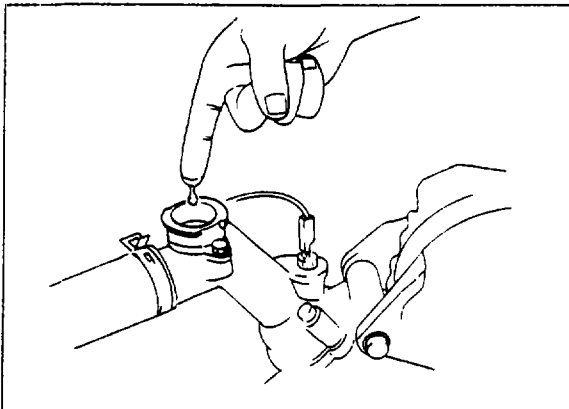

67U03X-009

Coolant Quality

1. Check to be sure that there is no excessive deposit of rust or scales around the filler cap or coolant filler port. If necessary, replace the coolant.
2. Check that the coolant is free from oil. If necessary, replace the coolant.



67U03X-010

Replacement

1. Remove the coolant filler cap and the air bleeder plug on the radiator.
2. Open the drain plug in the radiator and in the intermediate housing, let the coolant drain out.

Warning

Never remove the coolant filler cap while the engine is hot.

Wrap a thick cloth around the cap and carefully remove the cap.

3 INSPECTION

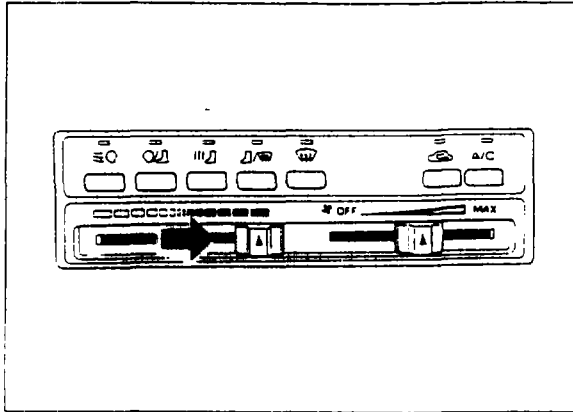

67U03X-011

Anti-freeze solution mixture percentage

Protection	Mixture percentage (by volume)	
	Anti-freeze solution	Water
Above -16°C (3°F)	35	65
Above -26°C (-15°F)	45	55
Above -40°C (-40°F)	55	45

87U03X-002

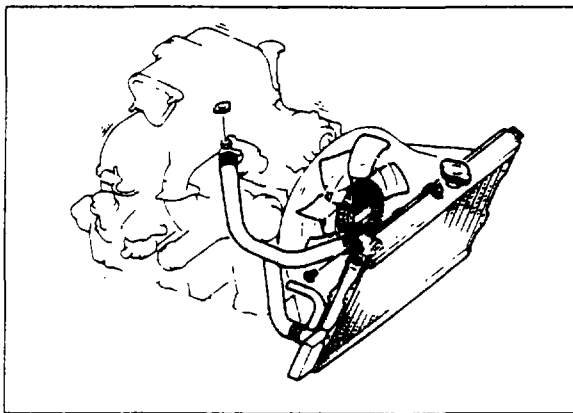

67U03X-013

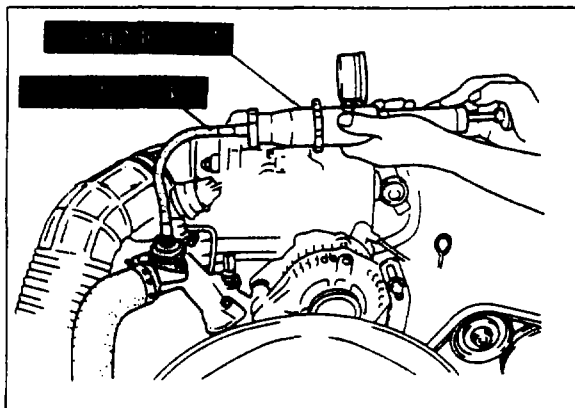

67U03X-014

3. Adjust the heater control to the maximum heat.
4. Flush the cooling system with water until all traces of color are gone, then let the system drain completely.

5. Retighten the drain plug.
6. Add the necessary amount of ethylene glycol-based coolant.

Caution

- a) Do not use alcohol- or methanol-based coolants.
- b) Use only soft (demineralized) water in the coolant mixture.

7. Run the engine at idle with the filler cap removed, and slowly add additional coolant as necessary.
8. Reattach the filler cap and air bleeder plug. Inspect all connections for leaks.

COOLANT CIRCUIT

1. Connect a tester using the **adaptor set** (49 9200 145-consists of 49 9200 146 and 49 9200 147) to the coolant filler port.
2. Apply pressure of **103 kPa (1.05 kg/cm², 15 psi)** to the circuit.
3. Check that the pressure does not decrease. If it does, there may be a coolant leak. Check for any leaks.

Warning

When removing either the filler cap or the tester, loosen it slowly until the pressure drops to zero, and then remove it.

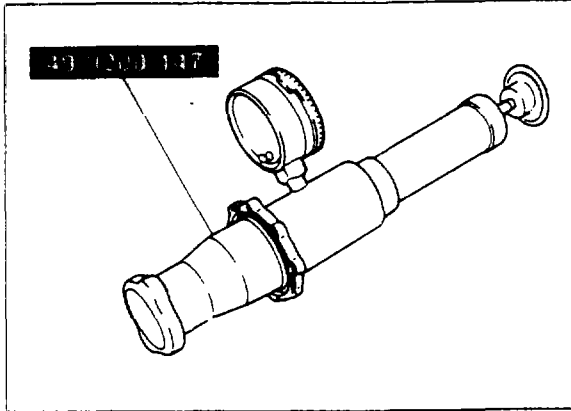

87U03X-003

COOLANT FILLER CAP

Relief Valve

1. Remove water residue from the filler cap valve and the negative-pressure valve seat.
2. Attach the filler cap to a tester using **adaptor B** (49 9200 147). Apply pressure gradually to **74–103 kPa (0.75–1.05 kg/cm², 11–15 psi)**.
3. Check that the pressure does not decrease.

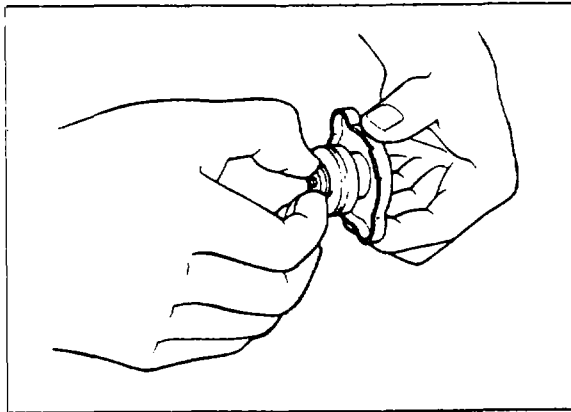

67U03X-016

Negative Pressure Valve

1. Pull the negative pressure valve to open it. Check to be sure it closes completely when released.
2. Check for damage on the contact surfaces, and for cracked or deformed seal packing.

Replace the radiator cap if necessary.

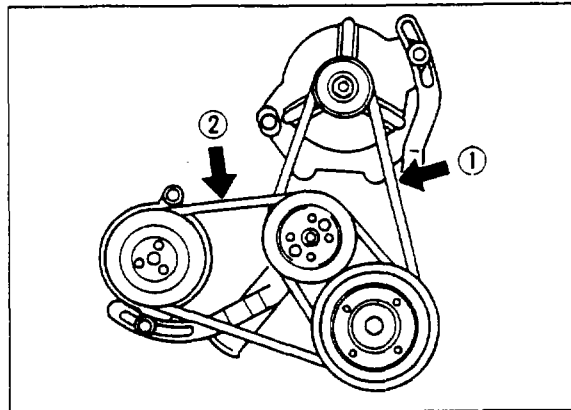

77U03X-102

COOLING FAN BELT

1. Inspect all surfaces of the fan belt. If it is cracked or damaged, replace it.
2. Check the amount of deflection by applying a pressure of about **98N (10 kg, 22 lb)**.

Deflection

1. **Alternator:** 14–17 mm (0.55–0.67 in)
2. **Air pump**
Turbo: 8–10 mm (0.31–0.39 in)
Non-Turbo: 11–13 mm (0.43–0.51 in)

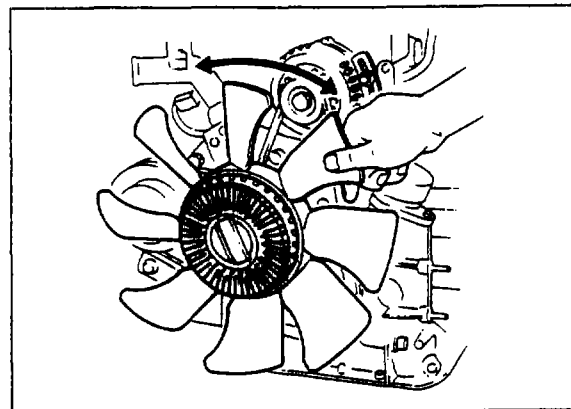

67U03X-018

THERMO-MODULATED FAN

1. Inspect the following items; replace if necessary.
 - (1) Fluid leakage from the fan drive clutch
 - (2) Deformation of the bimetal
 - (3) Excessive play of the cooling fan bearing
 - (4) Grease leakage from the cooling fan bearing
2. When the engine is warm, turn the cooling fan by hand and check that resistance is felt. If not felt, replace the fan drive clutch.

3 WATER PUMP

WATER PUMP

REMOVAL AND INSTALLATION

1. Disconnect the negative battery cable.
2. Turn the eccentric shaft so that the top mark of the pulley is aligned with the indicator pin.
3. Drain the engine coolant from the radiator drain plug.
4. Remove in the sequence shown in the figure
5. Install in the reverse order of removal.
6. Check for coolant leakage and check the coolant level.

67U03X-019

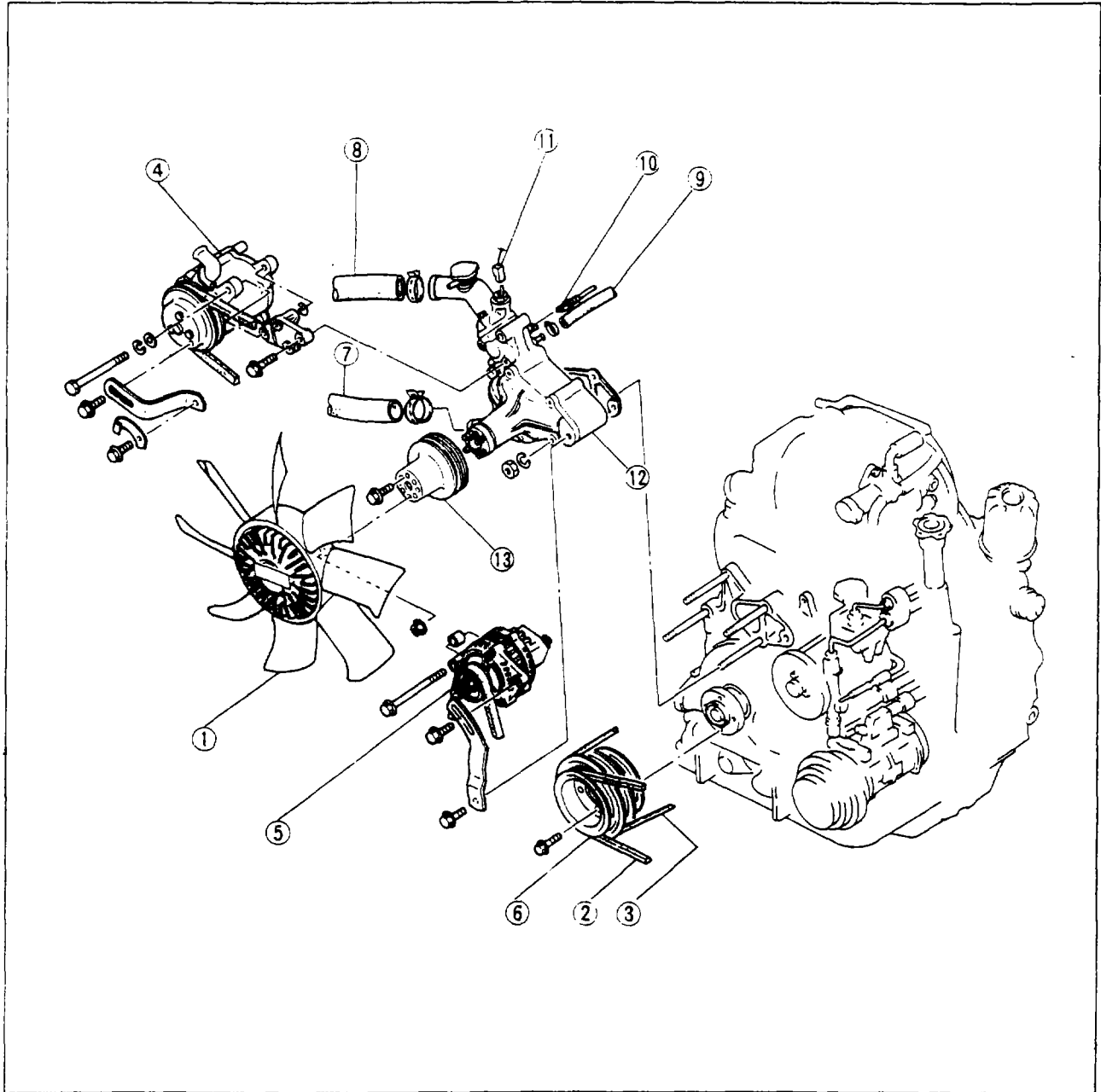

87U03X-004

- | | |
|------------------------------|---|
| 1. Cooling fan | 8. Upper radiator hose |
| 2. P/S pump drive belt | 9. Coolant bypass hose |
| 3. A/C compressor drive belt | 10. Water thermo sensor connector |
| 4. Air pump and drive belt | 11. Water thermo switch connector (for A/T) |
| 5. Alternator and drive belt | 12. Water pump |
| 6. Eccentric shaft pulley | 13. Cooling fan pulley |
| 7. Lower radiator hose | |

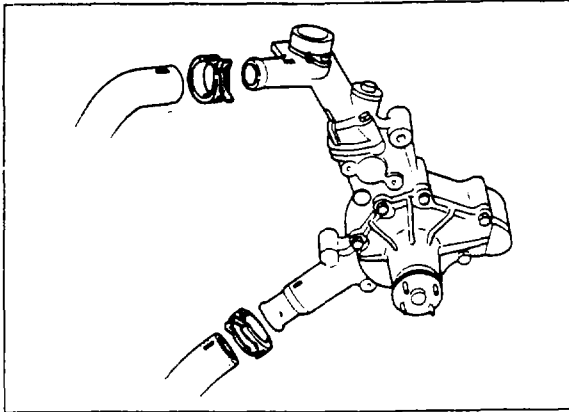

67U03X-021

Installation Note

Upper and lower radiator hoses

Install the hoses with the alignment marks aligned.

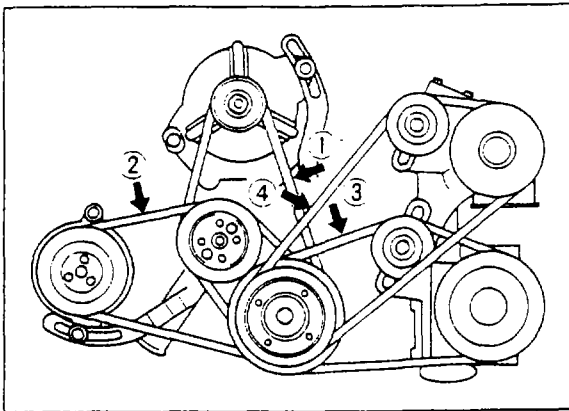

77U03X-103

Drive belt

Adjust the drive belt tension. Apply pressure (**98N, 10kg, 22 lb**) midway between the pulleys, and check the deflection.

Drive belt		Deflection	
1	Alternator	14—17 mm (0.55—0.67 in)	
2	Air pump	Turbo	8—10 mm (0.31—0.39 in)
		Non-turbo	11—13 mm (0.43—0.51 in)
3	A/C compressor	6—8 mm (0.24—0.31 in)	
4	P/S pump	11—13 mm (0.43—0.51 in)	

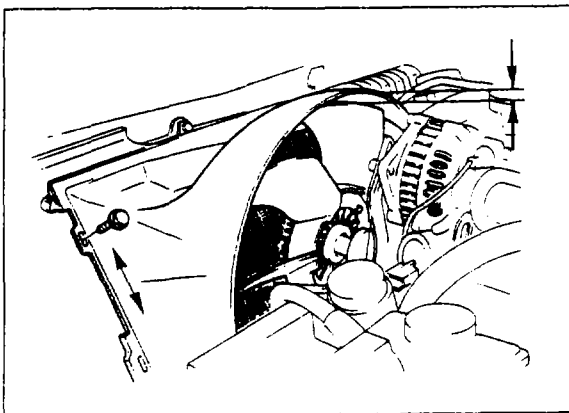

67U03X-023

Cooling fan

Check for cooling fan clearance, if necessary move the radiator cowl and adjust the clearance.

Cooling fan clearance:

16—24 mm (0.63—0.94 in)

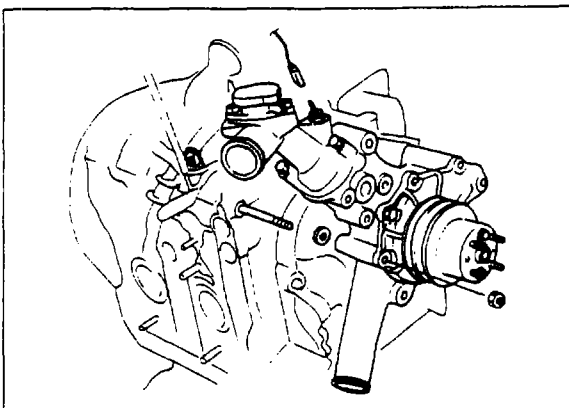

67U03X-024

Water pump

1. Install the two spacers on the studs where the gasket does not mount.
2. Install the water pump with a new gasket.

Tightening torque:

18—26 N·m (1.8—2.7 m·kg, 13—20 ft·lb)

3 WATER PUMP

DISASSEMBLY AND ASSEMBLY

1. Disassemble in the sequence shown in the figure.
2. Assemble in the reverse order of disassembly.

67U03X-025

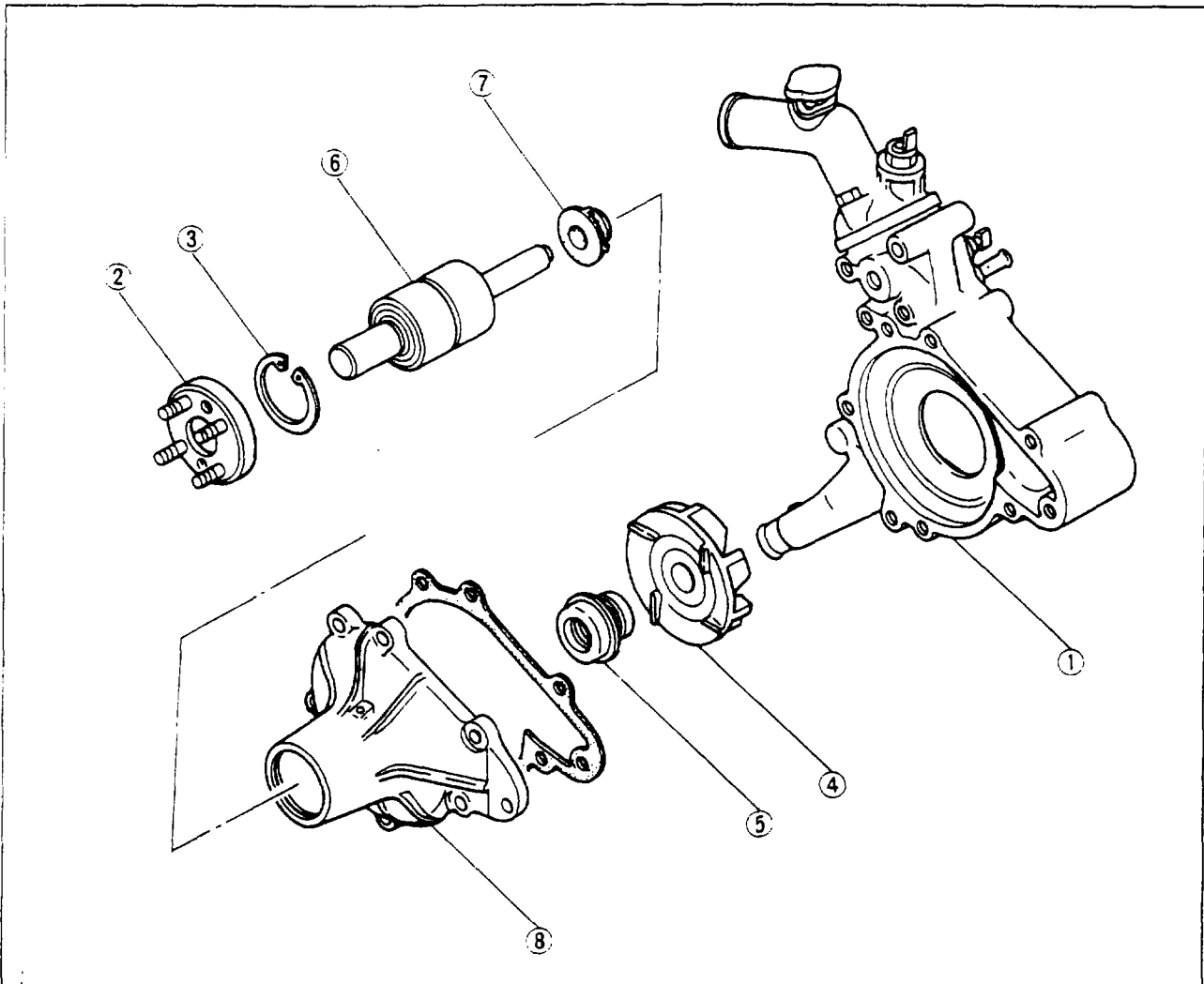

67U03X-026

- | | |
|--|--------------------|
| 1. Water pump body and thermostat assembly | 5. Water seal |
| 2. Pulley boss | 6. Shaft bearing |
| 3. Snap ring | 7. Baffle plate |
| 4. Impeller | 8. Bearing housing |

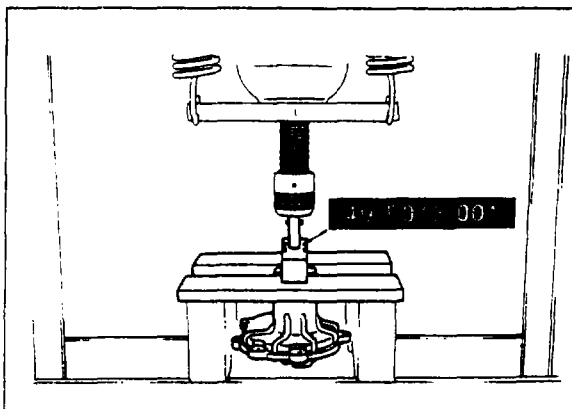

67U03X-027

Disassembly Note

Pulley boss

Remove the pulley hub using the **pulley boss puller and installer** (49 F015 001).

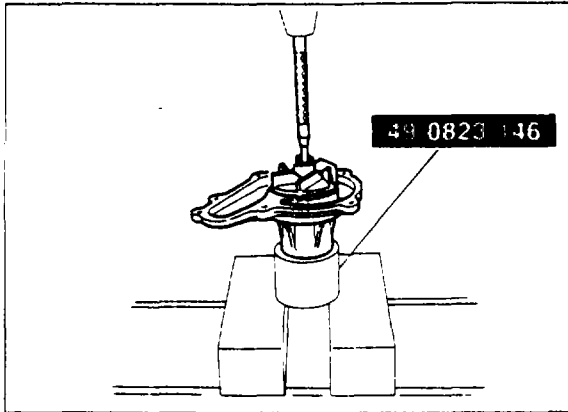

67U03X-028

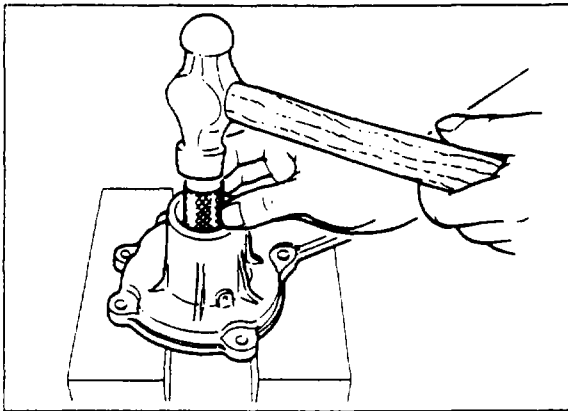

67U03X-029

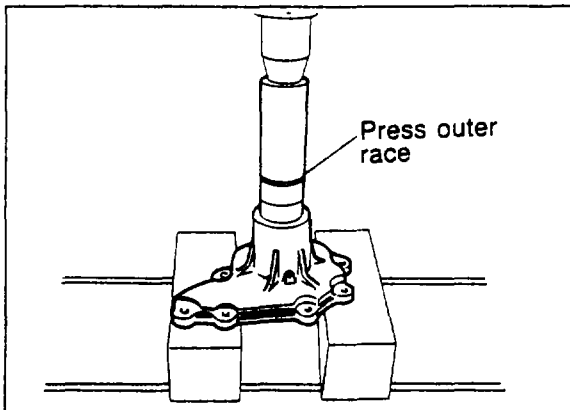

67U03X-030

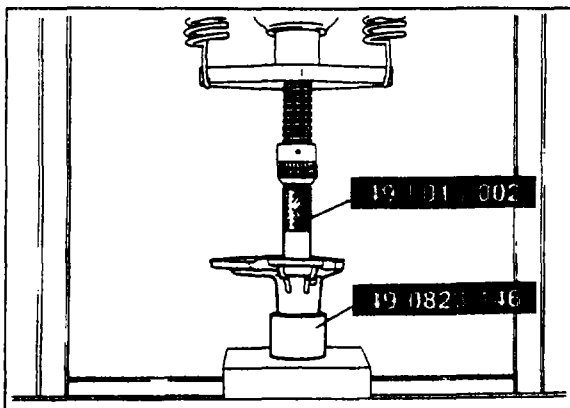

67U03X-031

Shaft bearing, water seal and baffle plate

1. Support the bearing housing using the **support block** (49 0823 146).
2. Press out the shaft bearing.
3. Remove the baffle plate from the shaft bearing.

4. Remove the water seal by tapping lightly with a hammer.

Assembly Note

Shaft bearing

1. Install a new baffle plate on the shaft.
2. Install the shaft bearing by pressing against the outer race.
3. Install the snap ring.

Water seal

1. Apply coolant to the new water seal and the shaft.
2. Press the water seal in straight using the **water seal installer** (49 F015 002).

3 WATER PUMP

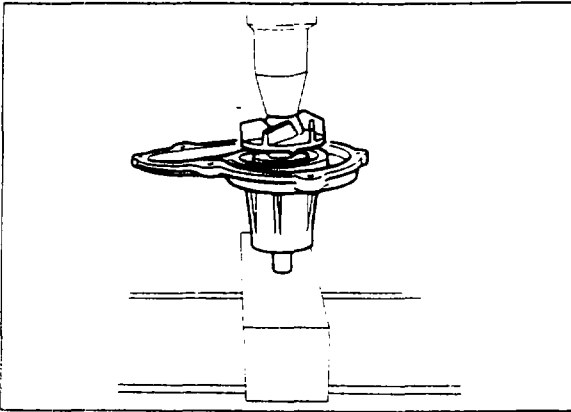

67U03X-032

Impeller

Support the shaft and press on the impeller so that it is flush with the end of the shaft.

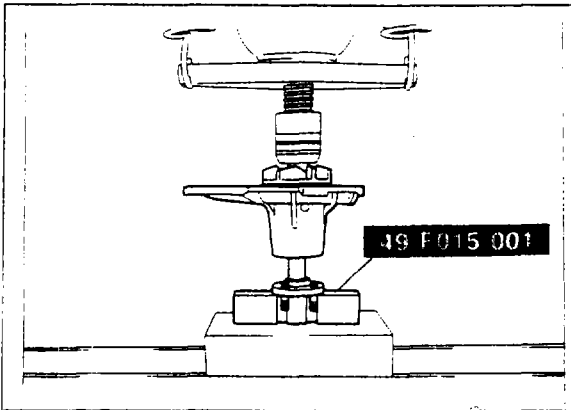

67U03X-033

Pulley boss

Press on the pulley boss using the **pulley boss puller and installer** (49 F015 001).

The shaft protrusion is as specified.

Protrusion: 8.3—9.1 mm (0.33—0.36 in)



67U03X-034

INSPECTION

Water Pump Body and Bearing Housing

Check the water pump body and bearing housing for cracks or damaged gasket surfaces, replace if necessary.

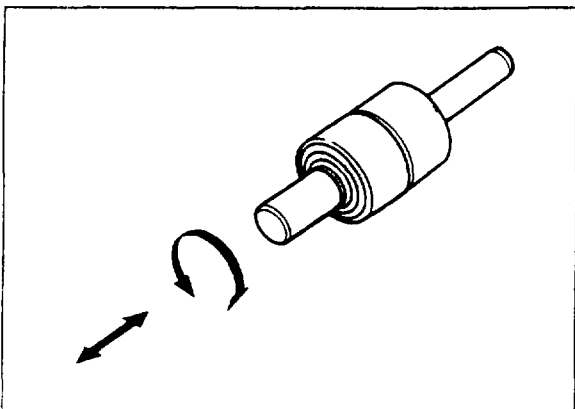

67U03X-035

Shaft Bearing

Check the shaft bearing for roughness or excessive end play.

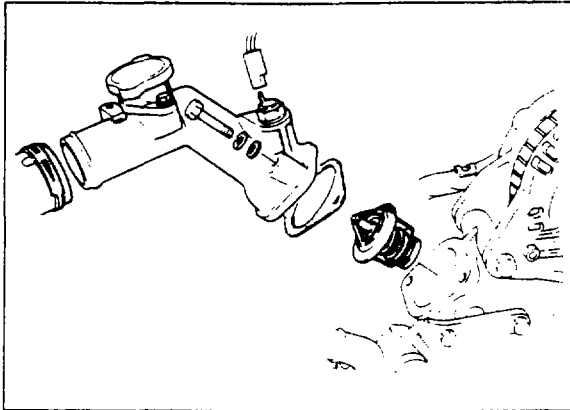

67U03X-036

THERMOSTAT

REMOVAL

1. Drain the coolant from the radiator drain plug.
2. Remove the following parts:
 - (1) Upper radiator hose
 - (2) Water thermo switch connector
 - (3) Thermostat cover
 - (4) Gasket
 - (5) Thermostat

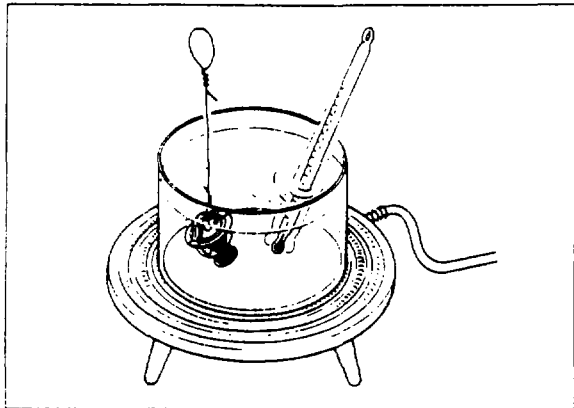

67U03X-037

INSPECTION

Check the operation, replace if necessary.

1. Visually check the valve to be sure it is air tight.
2. Place the thermostat and a thermometer in water, gradually increase the water temperature, and check the initial opening temperature, the full-open temperature, and the full-open lift.

Initial opening temperature:

80.5—83.5°C (177—182°F)

Full open temperature: 95°C (203°F)

Full open lift: 8.5 mm (0.34 in) min.

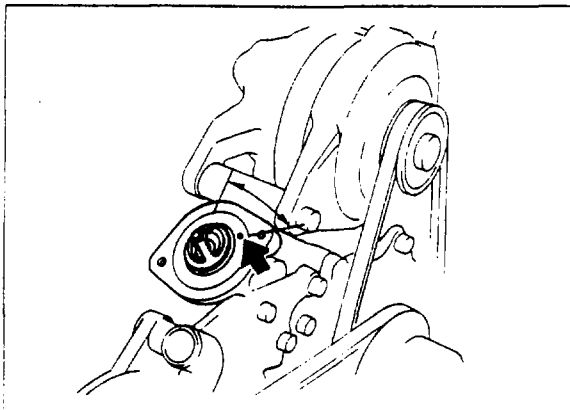

67U03X-038

INSTALLATION

1. Install the thermostat with the jiggle pin upward.
2. Install the thermostat cover with a new gasket.
3. Connect the water thermo switch connector.

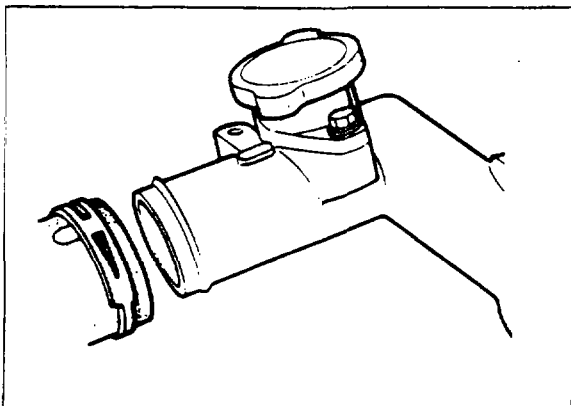

67U03X-039

4. Install the upper radiator hose with the alignment mark aligned.
5. Refill the coolant.
6. Run the engine, and check for coolant leakage and coolant level.

3 RADIATOR

RADIATOR

REMOVAL AND INSTALLATION

1. Drain the coolant from the radiator drain plug.
2. Remove in the sequence shown in the figure.
3. Install in the reverse order of removal.
4. Check the clearance between the cooling fan and cowling.
5. Check for coolant leakage and check the coolant level.

67U03X-040

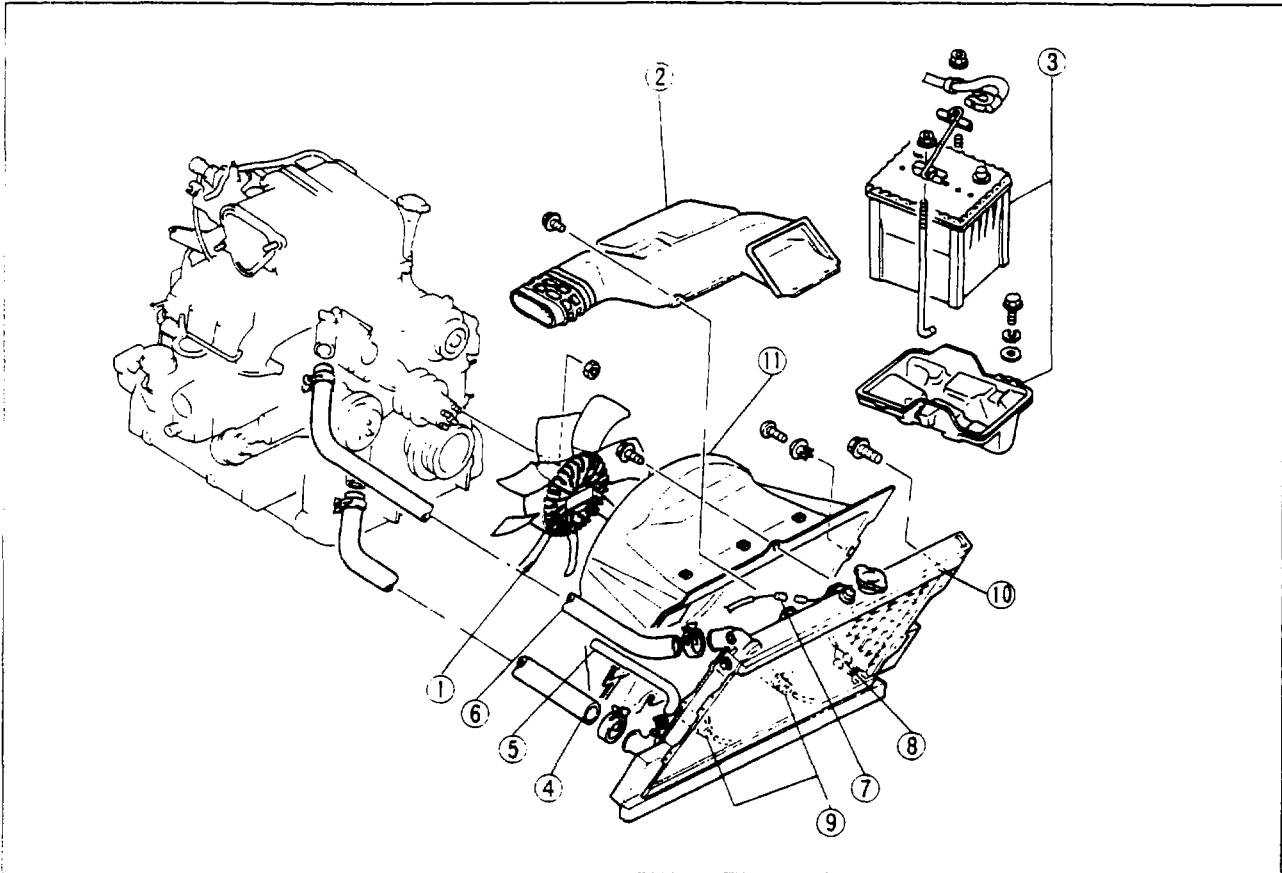

67U03X-041

- | | |
|------------------------|--|
| 1. Cooling fan | 7. Coolant level sensor connector |
| 2. Air intake pipe | 8. Radiator switch connector |
| 3. Battery and bracket | 9. ATF hose (only for A/T — Plug hoses.) |
| 4. Lower radiator hose | 10. Radiator |
| 5. Heater hose | 11. Radiator cowling |
| 6. Upper radiator hose | |

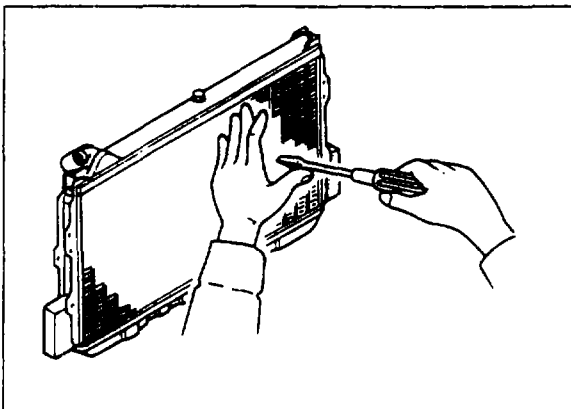

67U03X-042

INSPECTION

Check the following points, and repair or replace if necessary.

1. Cracks, damage, or water leakage
2. Bent fins (Repair by using a screwdriver.)
3. Distorted or bent radiator inlet

ELECTRICAL FAN

SYSTEM CIRCUIT

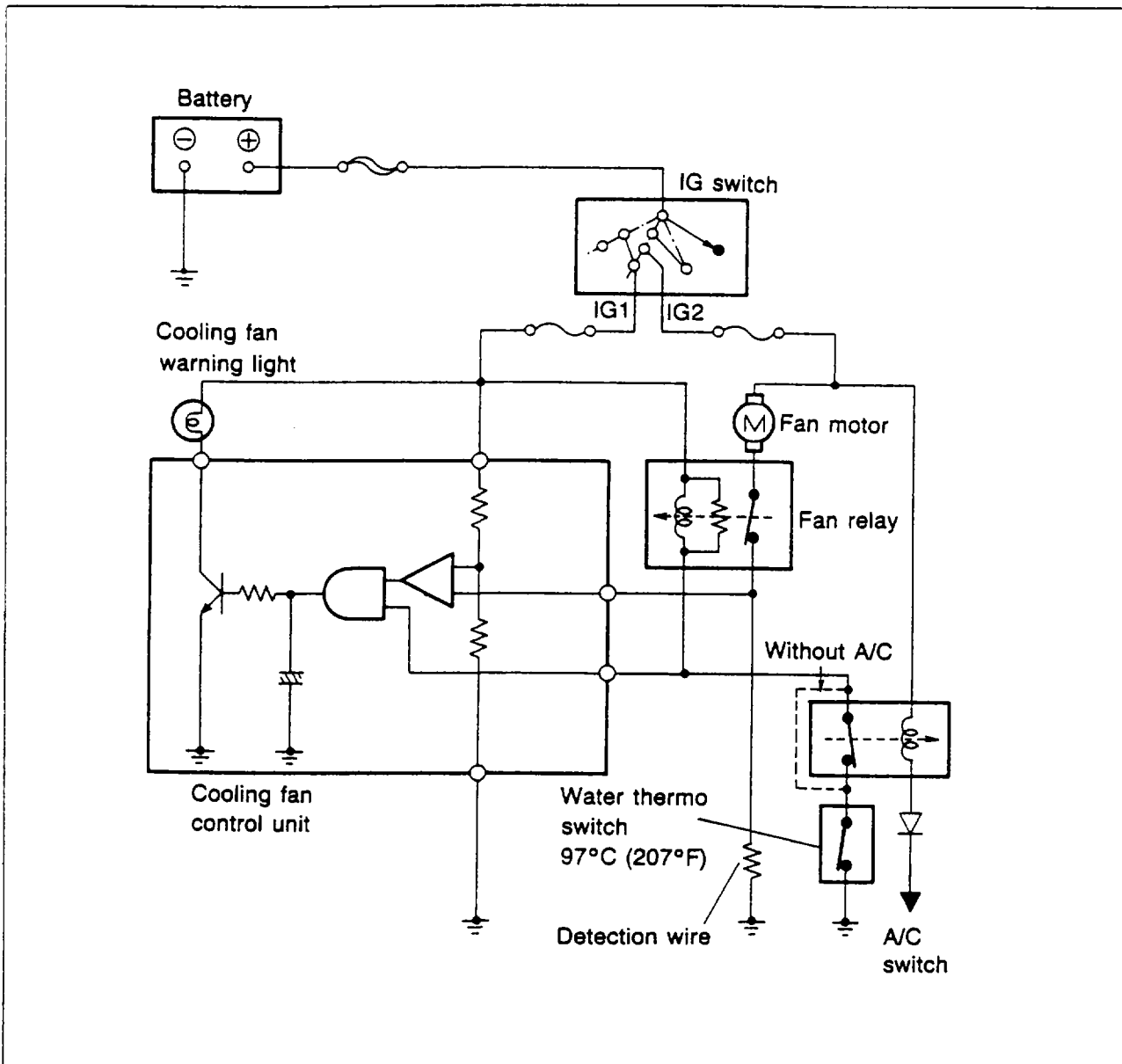

77U03X-104

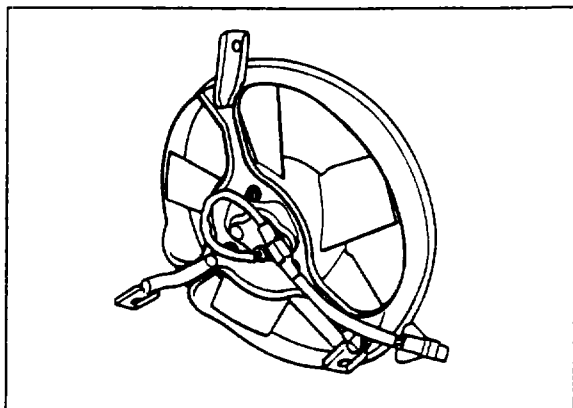

67U03X-044

INSPECTION

Fan Motor

1. Connect an ammeter and the battery to the fan motor connectors.
2. Check the fan motor for the operation and the current. If necessary, replace the fan motor.

Standard current: 2.4—2.6 A

3 ELECTRICAL FAN

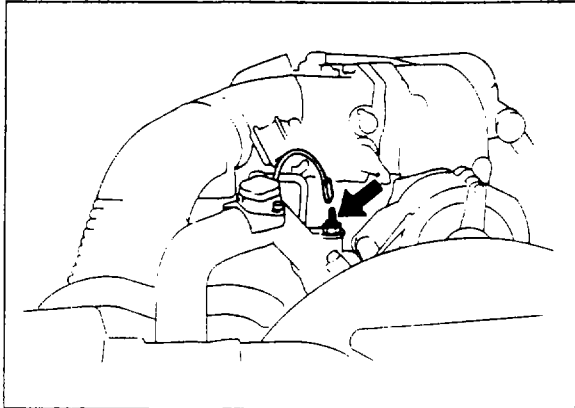

67U03X-045

Water Thermo Switch

1. Remove the water thermo switch for the electrical fan.

Note

Confirm that the ignition switch is OFF. If not, the fan will operate when the connector is removed.

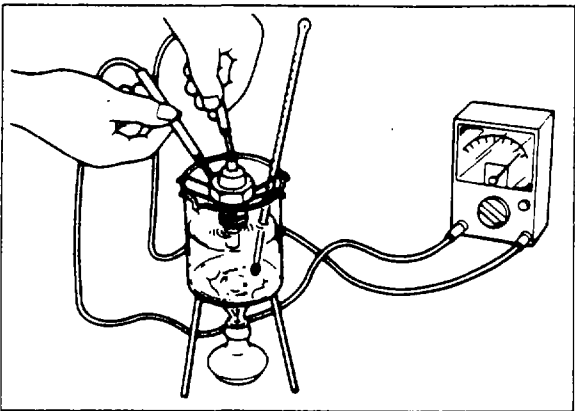

67U03X-046

2. Place the water thermo switch in water.
3. Check the continuity with a circuit tester.

Continuity 90°C (194°F) or less
No continuity..... 97°C (207°F) or more

4. If necessary, replace the water thermo switch.

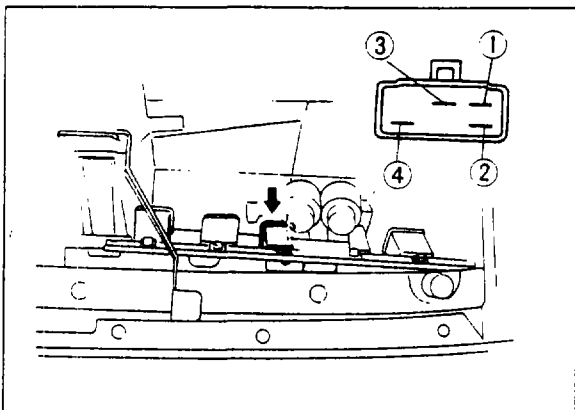

67U03X-047

Fan Relay

1. Check for continuity between terminals 1 and 2.
2. Check for continuity between terminals 3 and 4.
3. Apply battery voltage between terminal 1 and terminal 2, and check for no continuity between terminals 3 and 4.
4. If necessary, replace the fan relay.

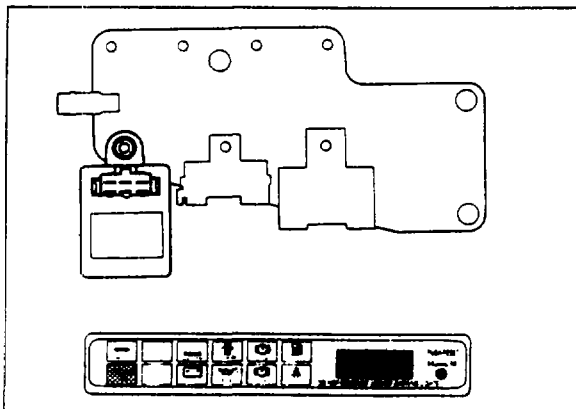

67U03X-048

Fan Control Unit

1. Turn the ignition switch ON, and check that the cooling fan warning light comes on.
2. Run the engine, and check that the cooling fan warning light goes out.
3. Disconnect the fan motor connector.
4. Disconnect the water thermo switch, and check that the cooling fan warning light comes on within 6 seconds.
5. Connect the water thermo switch.
6. Short across the fan motor connector with a jumper wire.
7. Disconnect the water thermo switch, and check that the cooling fan warning light comes on in 6 seconds.
8. If necessary, replace the cooling fan unit or warning light.