

RX-7

Factory Service Material

This manual can be downloaded for free from
<http://members.xoom.com/twinturboteddy/fsm/rx7.htm>

Or you can donate \$10 to diepat@earthlink.net through **paypal.com** and a gift CD with all manuals and resources I carry will be sent to you.

This includes

- 1993 Factory Service Manual
- 1988 Factory Service Manual
- 1995 Printed Microfiche of all parts
- 1989 Printed Microfiche of all parts*
- 1990 Printed Microfiche of all parts*
- 1986 Printed Microfiche of all parts*
- 1987 Printed Microfiche of all parts*
- 1988 Printed Microfiche of all parts*

The \$10 donation is used to offset the tremendous amount of time it takes to make everything available.



* These works are currently in process and may or not be readily available upon request. They will be hosted on the same link above and for download

MANUAL STEERING SYSTEM

OUTLINE	10A— 2
STRUCTURAL VIEW	10A— 2
SPECIFICATIONS	10A— 3
TROUBLESHOOTING GUIDE	10A— 4
ON-VEHICLE MAINTENANCE	10A— 5
STEERING WHEEL PLAY	10A— 5
LOOSENESS OR PLAY OF THIS	
STEERING WHEEL	10A— 5
STEERING WHEEL EFFORT	10A— 5
TIE-ROD END BOOT	10A— 6
REMOVAL AND INSTALLATION	10A— 6
INSPECTION AND ADJUSTMENT	10A— 8
FRONT WHEEL ALIGNMENT	10A— 8
STEERING WHEEL AND COLUMN	10A—10
REMOVAL	10A—10
INSPECTION	10A—11
INSTALLATION	10A—12
STEERING GEAR AND LINKAGE	10A—13
REMOVAL AND INSTALLATION	10A—13
DISASSEMBLY	10A—14
INSPECTION	10A—17
ASSEMBLY	10A—18

10A OUTLINE

OUTLINE

STRUCTURAL VIEW

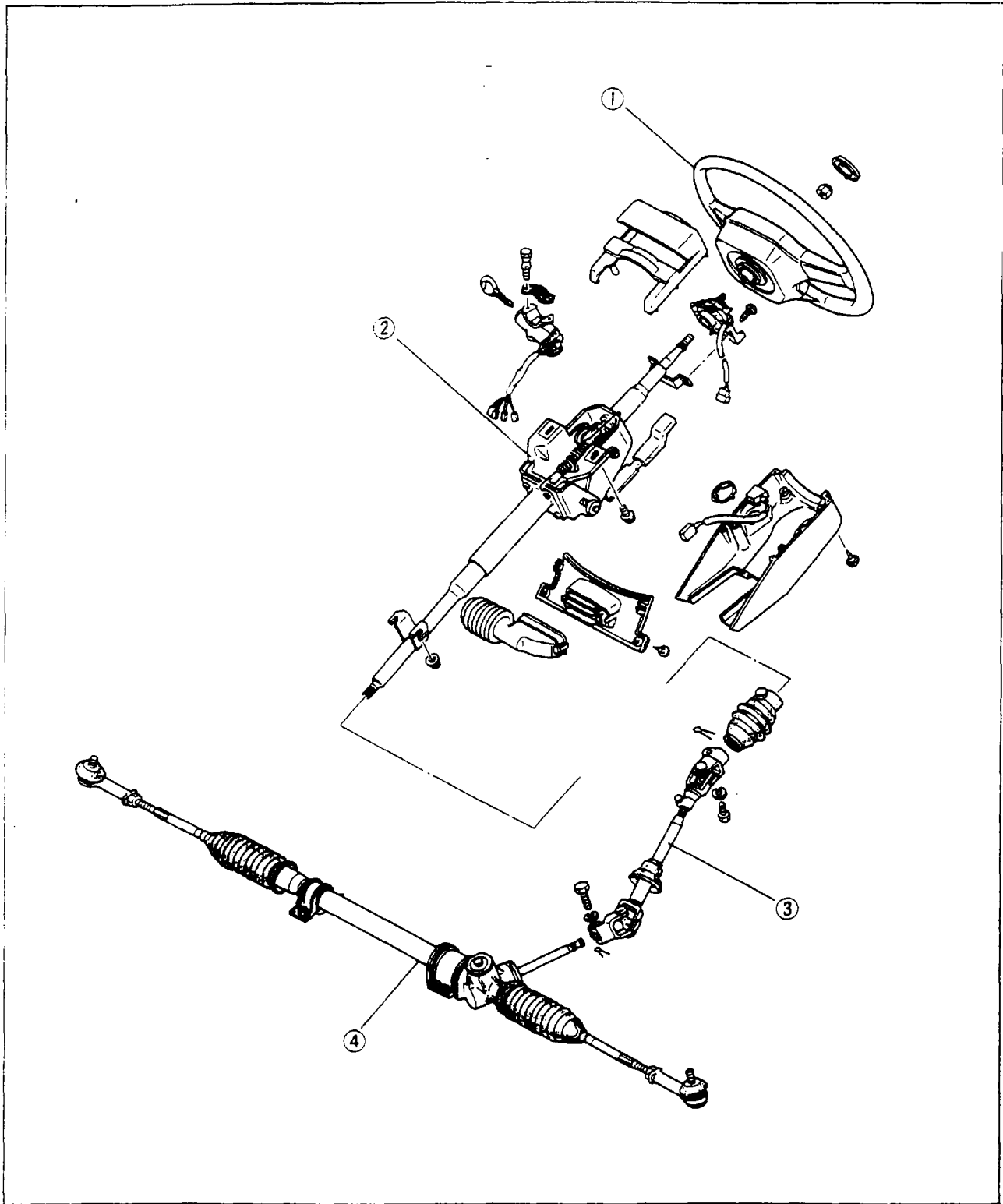

67U10A-002

- 1. Steering wheel
- 2. Steering shaft

- 3. Intermediate shaft
- 4. Steering gear housing and tie-rod

SPECIFICATIONS

Item	Specification	Manual steering
Steering wheel	Outer diameter mm (in)	380 (14.96)
Steering shaft and joints	Type	Collapsible
	Joint type	Cross joints (2)
	Tilt stroke mm (in)	35 (1.38)
Steering and linkage	Type	Rack and pinion
	Gear ratio	∞ (infinite)
	Rack stroke mm (in)	144 (5.67)
Maximum steering	Inner ($^{\circ}$)	37
	Outer ($^{\circ}$)	33
Wheel alignment	Toe-in mm (in)	3 ± 3 (0.12 ± 0.12)
	Camber angle	$0^{\circ} 20' \pm 30'$
	Caster angle	$4^{\circ} 40' \pm 45'$
	King-pin angle	$13^{\circ} 45'$
	Trail mm (in)	14.3 (0.52)

87U1CA 001

10A TROUBLESHOOTING GUIDE

TROUBLESHOOTING GUIDE

Problem	Possible Cause	Remedy	Page
Steering wheel hard to turn. (Jack up front of vehicle, both tires off ground and operate steering wheel)	Wheel turns easily		
	Insufficient tire air pressure	Adjust	—
	Excessively uneven wear of tire	Replace	—
	Excessive force required to turn wheel		
	Faulty lubrication, presence of foreign matter or abnormal wear of ball joint	Lubricate or replace	—
	Stuck or damaged ball joint	Replace	10A—6
	Improper adjustment of pinion shaft preload	Adjust	10A—19
	Damaged steering gear	Replace	—
	No grease in steering gear	Lubricate	—
Sticking lower-arm ball-joint	Replace	—	
Steering wheel pulls	Damaged steering linkage	Replace	10A—6
	Incorrect front wheel bearing preload adjustment	Adjust	—
	Fatigued front springs	Replace	—
	Damaged knuckle arm	Replace	—
	Brakes dragging	Adjust	—
	Incorrect wheel alignment (toe-in)	Adjust	10A—8
	Incorrect tire air pressure	Adjust	—
Unevenly worn tire	Replace	—	
Unstable driving, wanders	Deformed steering linkage	Replace	10A—6
	Worn or damaged steering system joint	Replace	—
	Incorrect pinion preload adjustment	Adjust	10A—19
	Incorrect front wheel bearing preload adjustment	Adjust	—
	Fatigued front spring	Replace	—
	Malfunction of shock absorber(s)	Replace	—
	Incorrect wheel alignment (toe-in)	Adjust	10A—8
	Incorrect tire air pressure	Adjust	—
Wheel(s) deformed or out of balance	Repair or replace	—	
Steering wheel vibrates	Incorrect wheel bearing preload adjustment or worn wheel bearing	Adjust or replace	—
	Damaged steering linkage	Replace	10A—6
	Worn or damaged steering system joint	Replace	10A—6
	Incorrect pinion preload adjustment	Adjust	10A—19
	Loose gear box mounting bolts	Tighten	10A—13
	Incorrect wheel alignment (toe-in)	Adjust	10A—8
	Incorrect tire air pressure	Adjust	—
	Unevenly worn tires	Replace	—
	Depth of tire tread different between left and right tires	Replace	—
	Wheels damaged or out of balance	Repair or replace	—
	Malfunctioning or loose shock absorber(s)	Replace or tighten	—
Excessive play in steering	Incorrect steering gear backlash adjustment	Adjust	10A-20
	Worn rack and pinion gear	Replace	—
	Worn or damaged steering system joint	Replace	10A—6
	Incorrect front wheel bearing preload adjustment	Adjust	—
Noise from steering system	Loose or worn steering linkage	Tighten or replace	10A—6
	Worn steering system joint	Replace	10A—6
	Incorrect steering gear backlash adjustment	Adjust	10A—24

67U10A 004

ON-VEHICLE MAINTENANCE

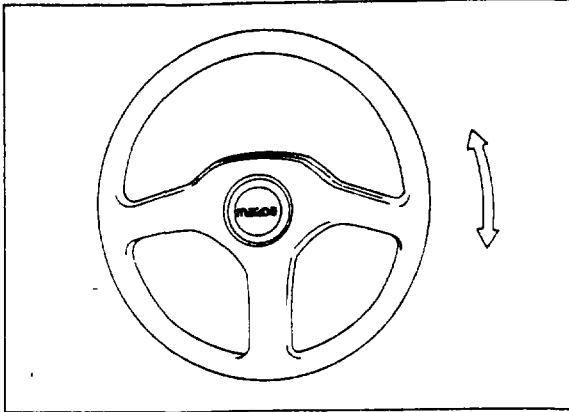

67U10A-005

STEERING WHEEL PLAY

With the wheels in the straight-ahead position, gently turn the steering wheel to the left and right and check that the play is within specification.

Play: 5—20 mm (0.20—0.79 in)

Note

If the play exceeds specification, either the steering joints are worn or the backlash of the steering gear is excessive.

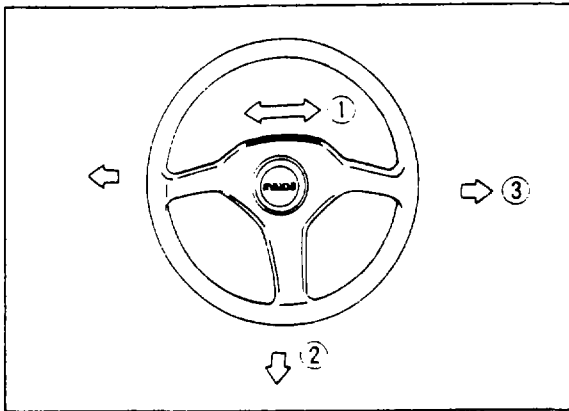

67U10A-006

LOOSENESS OR PLAY OF THE STEERING WHEEL

Move the steering wheel in the directions ①, ② and ③ to check for column bearing wear, steering shaft joint play, steering wheel looseness, or column looseness.

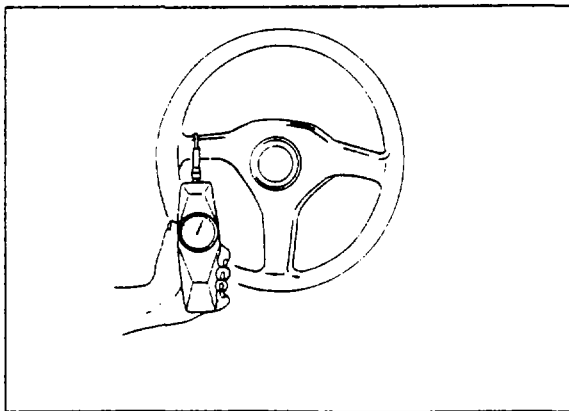

67U10A-007

STEERING WHEEL EFFORT

Manual Steering

1. Jack up the vehicle. Put the wheels in the straight-ahead position.
2. Measure the steering wheel effort by connecting a spring gauge to the outer circumference of the steering wheel.

Steering wheel effort:

5—8N (0.5—0.8 kg, 1—2 lb)

[during one turn of the steering wheel]

Note

Measure after turning the steering wheel to the left and right 5 times or more.

3. If the measured value exceeds specification, check the following points: rotation starting torque of the pinion, rotation torque of the ball-joints, and seizure of the joints.

67U10A-008

10A TIE-ROD END BOOT

TIE-ROD END BOOT

REMOVAL AND INSTALLATION

1. Jack up the front of the vehicle and support it with safety stands.
2. Remove in the sequence shown in the figure
3. Install in the reverse order of removal.

67U10A-009

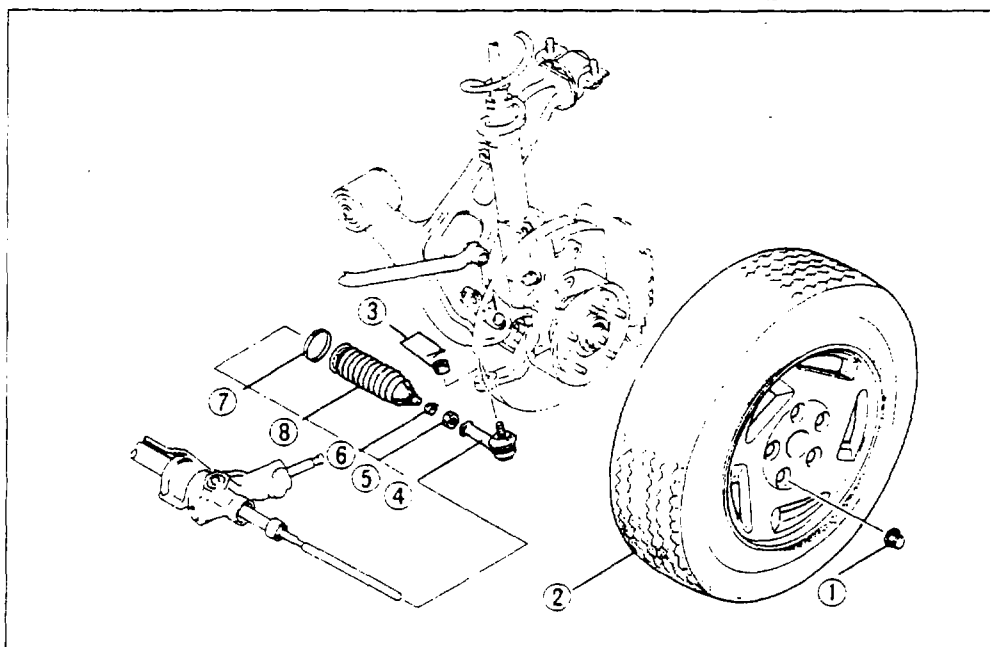

1. Wheel nuts
2. Wheel
3. Nut
4. Tie-rod end
5. Nut
6. Boot band
7. Boot wire
8. Boot

67U10A-010

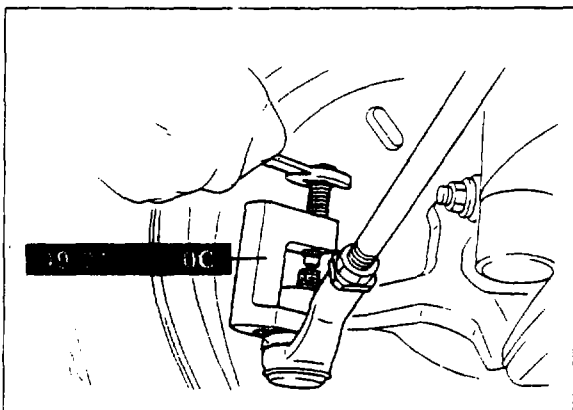

48G10X-614

Tie-rod End

Separate the tie-rod end from the knuckle using the **ball-joint puller** (49 0118 850C).

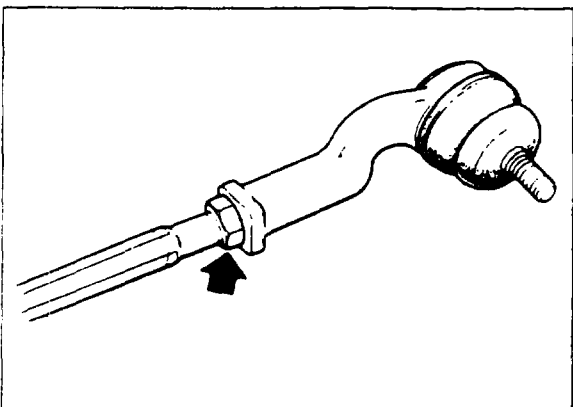

58U10X-608

Nut

Before removing the nut from the tie-rod end, make a mark for reference during installation. Tighten the nut to that mark during installation.

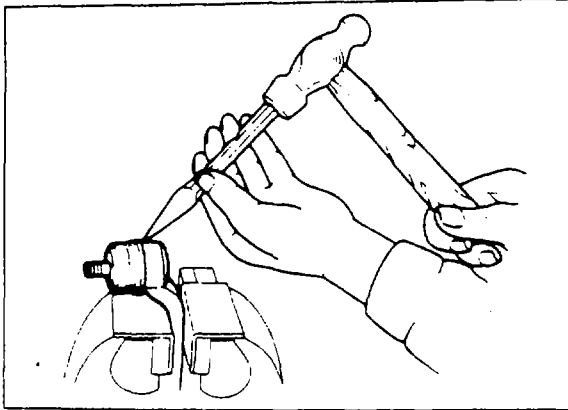

58U10X-609

Boot

Secure the tie-rod end in a vise. Place a chisel against the boot and hold it at the angle shown in the figure, remove the boot by tapping the chisel with a hammer.

Caution

Be careful not to scar the part where the boot is attached to the tie-rod end.

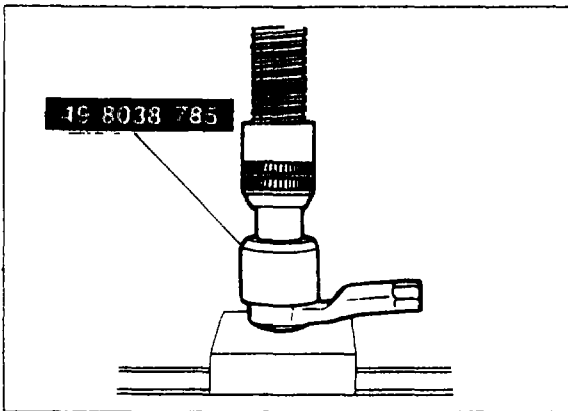

67U10A-011

Insert a small amount of grease (lithium base, NLG! No. 2) into the new boot and set it onto the **dust-boot installer** (49 8038 785). Install the boot to the tie-rod end using a press.

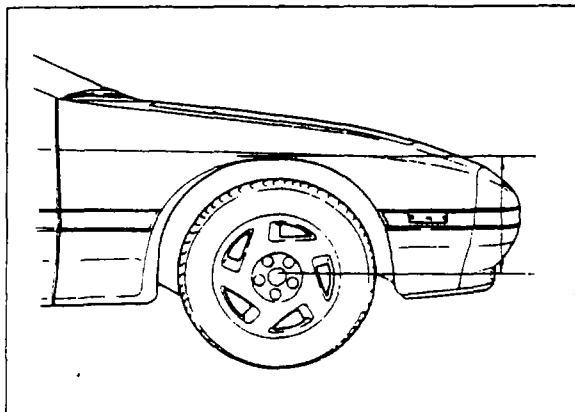

67U10A-012

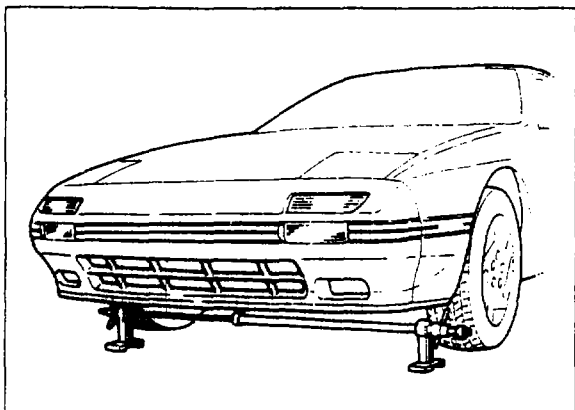

67U10A-013

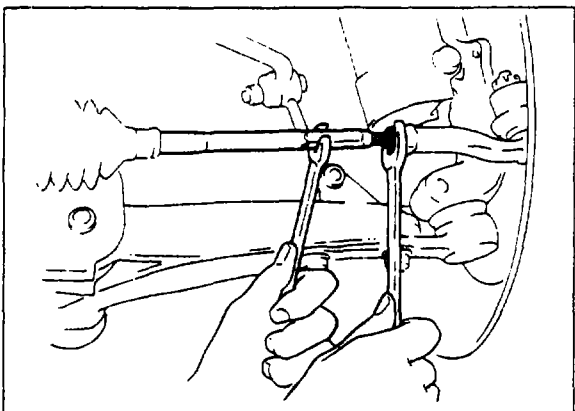

67U10A-014

INSPECTION AND ADJUSTMENT

FRONT WHEEL ALIGNMENT

Pre-inspection

1. Check the tire inflation and bring to the recommended pressure.
2. Inspect the front wheel bearing play and correct if necessary.
3. Inspect the wheel and tire run-out.
4. Inspect the ball joints and steering linkage for any excessive looseness.
5. The vehicle must be on level ground and have no luggage or passenger load.
6. The difference in height from the center of wheel to the fender brim between the left and right sides must be within **10 mm (0.39 in)**.

Toe-in

Inspection

1. Raise the front of the vehicle until the wheels clear the ground.
2. Turn the wheels by hand, mark a line in the center of each tire tread by using a scribing block.
3. Place the front wheels in the straight-ahead position and lower the vehicle.
4. Measure the distance between the lines at the front and rear of the wheels.

Both measurements must be taken at equal distances from the ground.

Toe-in (distance greater at rear than front):
 3 ± 3 mm (0.12 ± 0.12 in)

Adjustment

To adjust the toe-in, loosen the left and right tie-rod lock nuts, and turn the tie-rods by the same amount.

Caution

- a) The left and right tie-rods are both right threaded, so, to increase the toe-in, turn the right tie-rod toward the front of the vehicle, and turn the left tie-rod by the same amount toward the rear.
- b) One turn of the tie-rod (both sides) changes the toe-in by about 30 mm (1.21 in).
- c) Tighten the tie-rod lock nuts to the specified torque.

Tightening torque:

69—78 N·m (7—8 m·kg, 51—58 ft·lb)

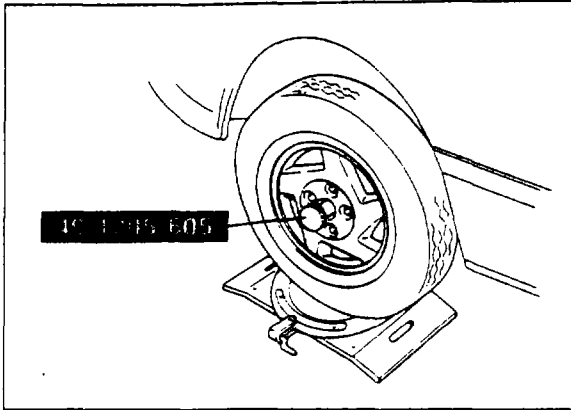

67U10A-015

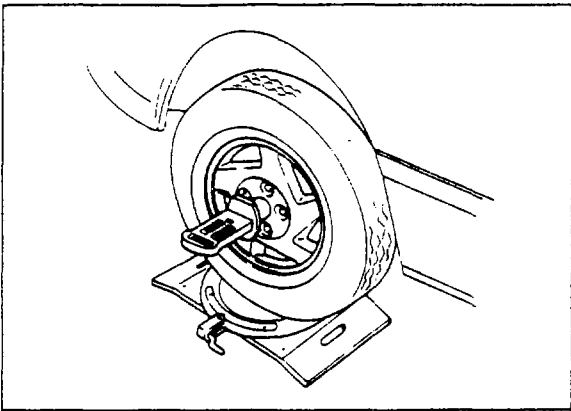

87U10A-002

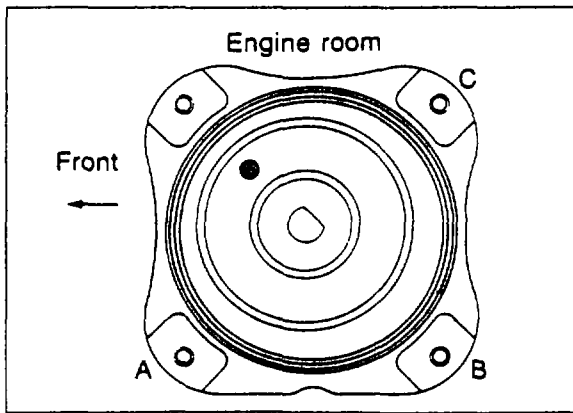

87U10A-003

Mark	Difference from standard position	
	Camber angle	Caster angle
A	0°	30'
B	30'	30'
C	30'	-0°

87U10A-006

Camber and Caster

Inspection

The camber and caster is measured by placing the front wheels on a turning-radius gauge in accordance with the manufacturer's instructions.

Proceed in the following order:

1. Jack up the vehicle and remove the wheel caps and nuts. Then attach the **caster/camber gauge adaptor** (49 1205 605) to the wheel hub as shown in the figure.

2. Attach the caster/camber gauge to the adaptor, and then measure the camber and caster.

Camber angle: 0°20' ± 30'

Caster angle: 4°40' ± 45'

Left/right difference:

Camber: 30' or less

Caster: 45' or less

Adjustment

1. Jack up the front end of the vehicle, and support it with safety stands.
2. Remove the nuts holding the mounting block to the fender.
3. Push the mounting block downward, and turn it to the desired position.
4. Retighten the nuts to the specified torque.

Note

The camber and caster is adjusted about 30' by changing the position of the mounting block.

Steering Angle (turning angle to left and right) Inspection

The steering angle is measured by placing the front wheels on a turning-radius gauge.

Inward 37° ± 2°

Outward 32° ± 2°

10A STEERING WHEEL AND COLUMN

STEERING WHEEL AND COLUMN

REMOVAL

1. Disconnect the negative battery cable.
2. Remove in the sequence shown in the figure.

67U10A-020

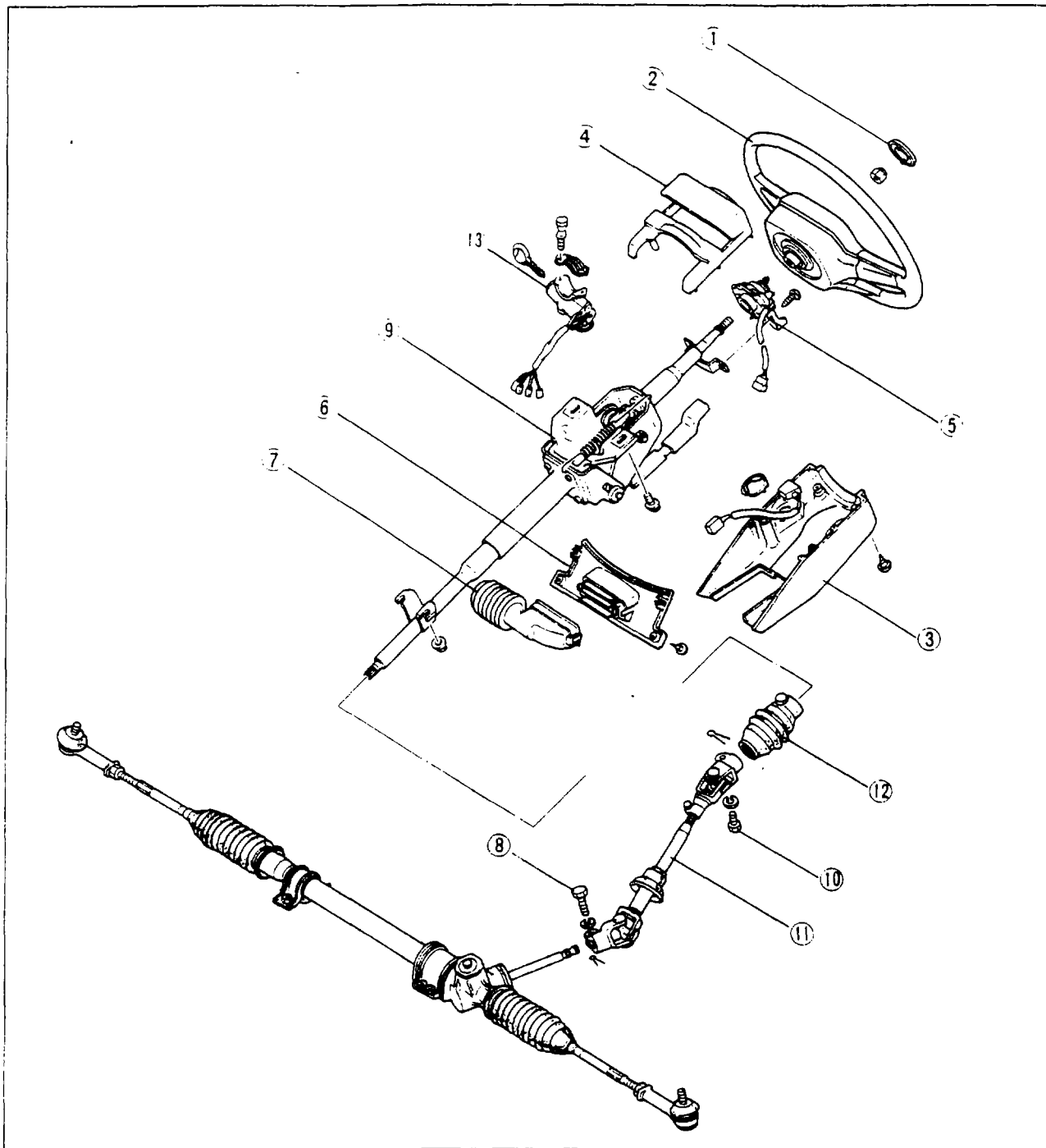

67U10A 021

- | | | |
|-------------------------|-----------------------|----------------------------|
| 1. Horn cap | 5. Combination switch | 9. Steering shaft assembly |
| 2. Steering wheel | 6. Cover | 10. Bolt |
| 3. Column cover (lower) | 7. Duct | 11. Intermediate shaft |
| 4. Column cover (upper) | 8. Bolt | 12. Rubber |
| | | 13. Steering lock |

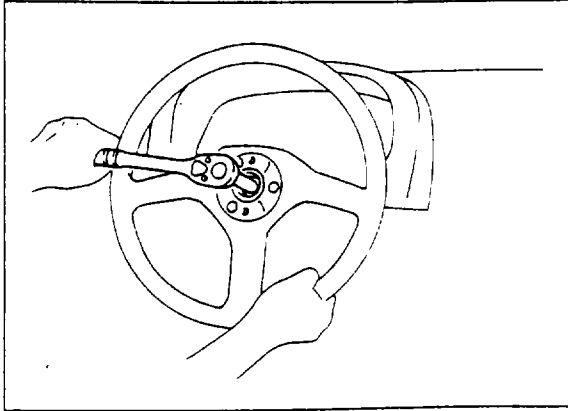

67U10A-022

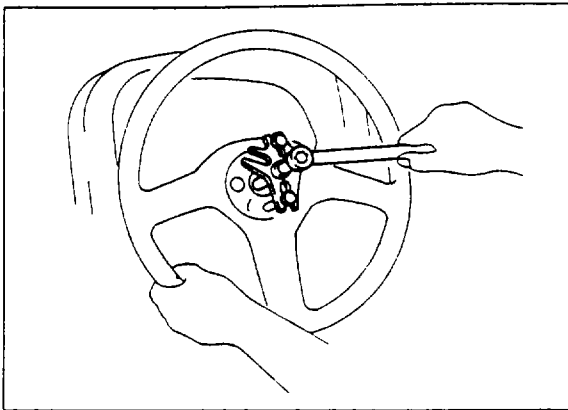

67U10A-023

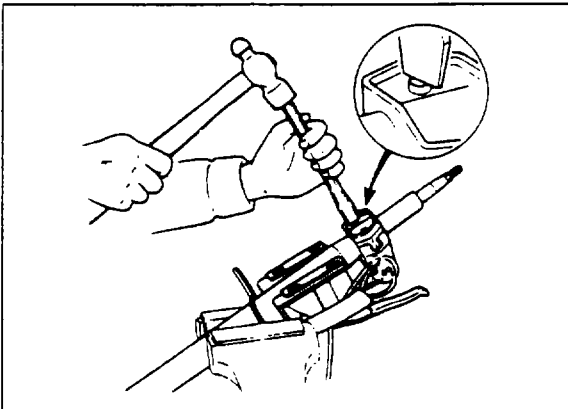

67U10A-024

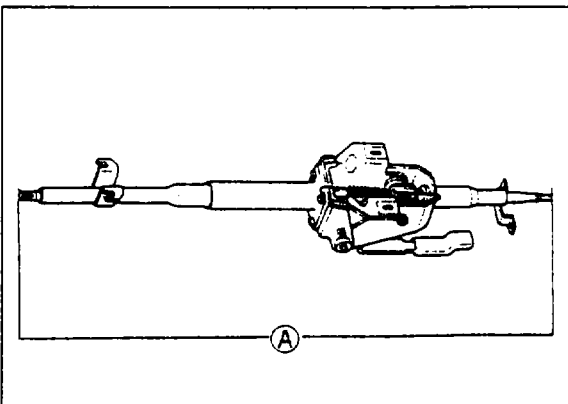

67U10A-025

Steering Wheel

1. Remove the horn cap and the lock nut.

2. The steering wheel must be removed using a suitable puller.

Steering Lock

Use a chisel to make a groove in the heads of the steering lock installation screws. Remove the screws using a flat-tipped screwdriver, and remove the steering lock.

INSPECTION

Check the following points, replace parts if necessary.

1. Dimensions of steering column.

Standard dimensions

816.1—814.9 mm (32.13—32.08 in)

2. Needle and ball bearings for wear.

3. Dust boot for damage.

10A STEERING WHEEL AND COLUMN

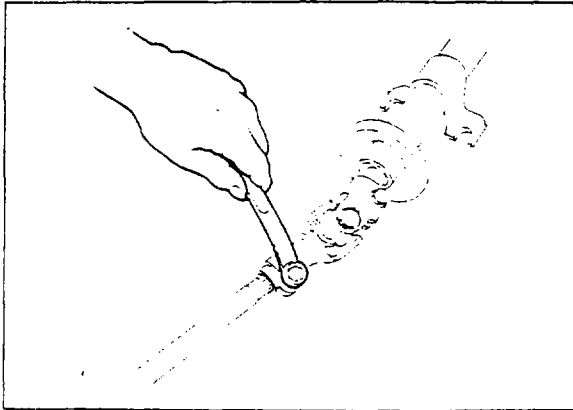

67U10A-026

INSTALLATION

1. Install the steering shaft assembly and tighten the bolt.

Tightening torque: (Universal joints)
18—25 N·m (1.8—2.5 m·kg, 13—18 ft·lb)

Caution

Coat the threads with a thread locking compound.

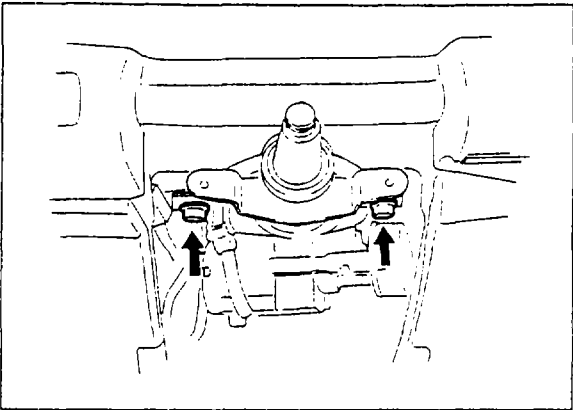

48G10X-632

2. Install the shaft assembly and tighten the bracket mounting bolts.

Tightening torque:
16—23 N·m (1.6—2.3 m·kg, 12—17 ft·lb)

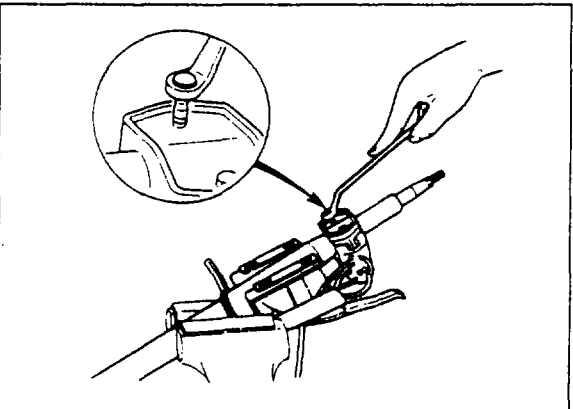

67U10A-027

3. After installing the steering lock to the jacket, use new steering lock mounting screws, and screw them in until the heads of the screws break off.

Caution

Check the operation of the lock while tightening the mounting screws.

4. Install the combination switch, and connect the coupler.
5. Install the column cover.
6. Align and install the steering wheel.

Steering wheel tightening torque:
39—49 N·m (4.0—5.0 m·kg, 29—36 ft·lb)

STEERING GEAR AND LINKAGE

REMOVAL AND INSTALLATION

1. Jack up the vehicle and support it with stands.
2. Disconnect the negative battery cable.
3. Remove in the sequence shown in the figure.
4. Install in the reverse order of removal.

67U10A-028

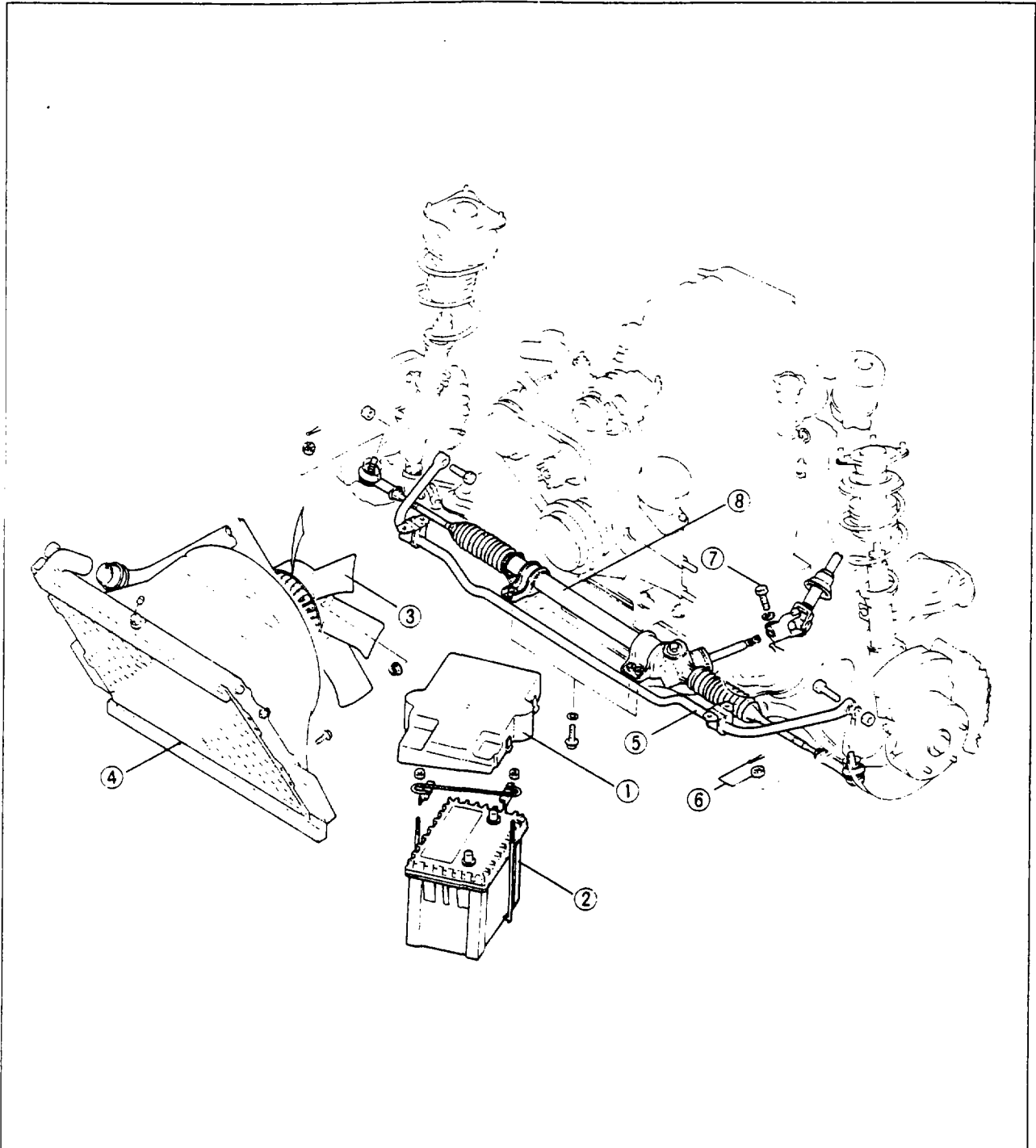

67U10A-029

1. Cover
2. Battery
3. Fan drive assembly

4. Radiator and cover
5. Stabilizer
6. Cotter pin and nut

7. Bolt
8. Steering gear and linkage

10A STEERING GEAR AND LINKAGE

DISASSEMBLY

Disassemble in the sequence shown in the figure.

Note

Before disassembling, clean thoroughly.

67U10A-030

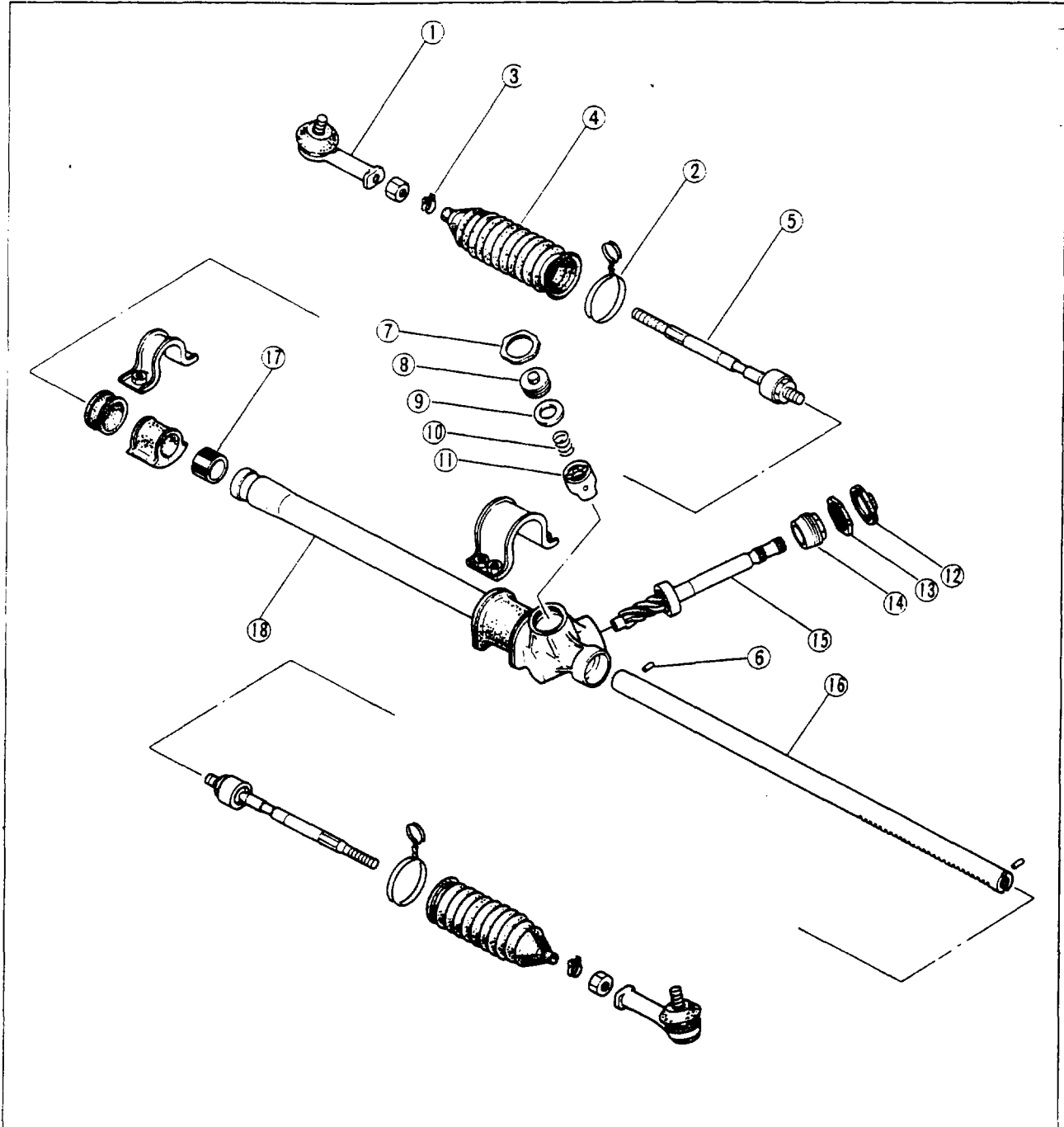

67U10A-059

- 1. Tie-rod end
- 2. Boot wire
- 3. Boot band
- 4. Boot
- 5. Tie-rod
- 6. Pin

- 7. Lock nut
- 8. Adjust cover
- 9. Yoke seat
- 10. Spring
- 11. Pressure pad
- 12. Dust cover

- 13. Lock nut
- 14. Rear cover and oil seal
- 15. Pinion
- 16. Rack
- 17. Bushing
- 18. Gear housing

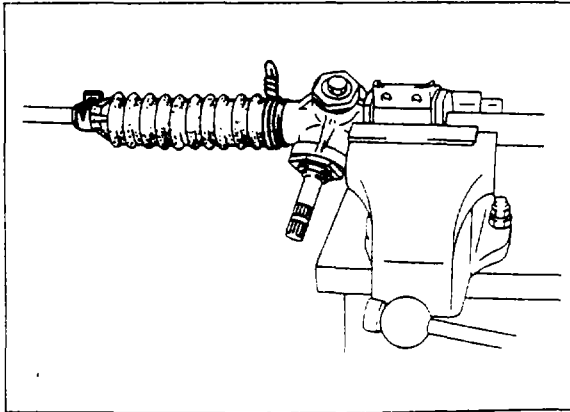

67U10A-032

Steering Gear and Linkage

Secure the gear and linkage in a vise.

Caution

Be sure to insert a soft, protective material (such as copper plates) between the part and the jaws of the vise.

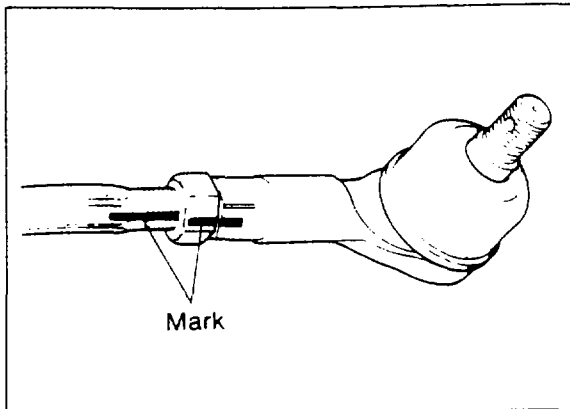

67U10A-033

Tie-rod Ends

Before removing the tie-rod ends, make a mark on the threaded portion of the tie-rods to use as a guide for installation.

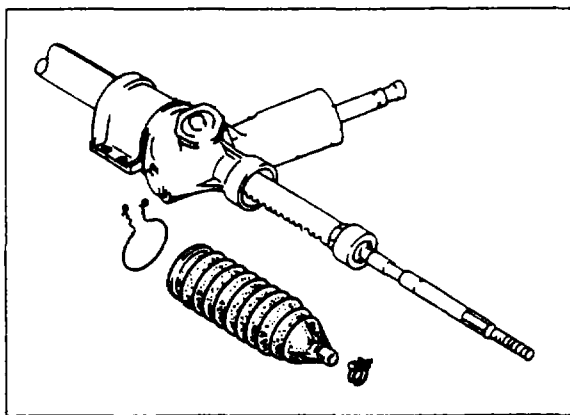

67U10A-034

Boots

Cut the boot wire.
Remove the clip and the boot.

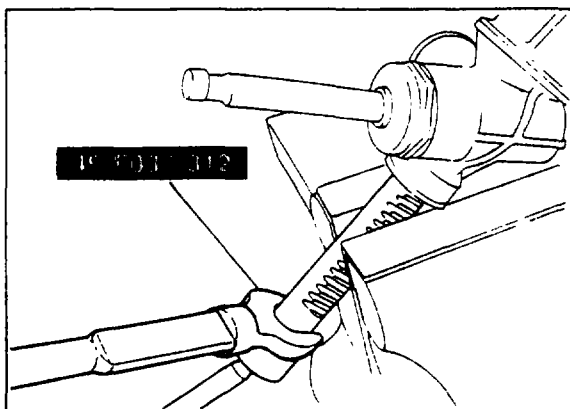

67U10A-035

Tie-rods

Secure the rack gear in a vise, and remove the tie-rods using **wrench** (49 F032 312). At this time, the pins will be pushed up by the rack. Remove the pins.

10A STEERING GEAR AND LINKAGE

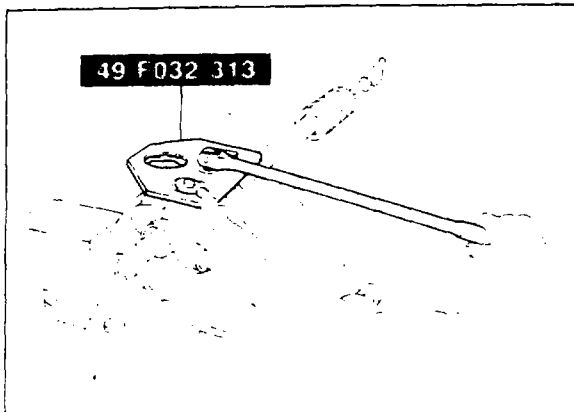

67U10A-036

Pressure Pad

1. Loosen the lock nut using **wrench** (49 F032 313), and remove the adjust cover and spring. Remove the pressure pad.

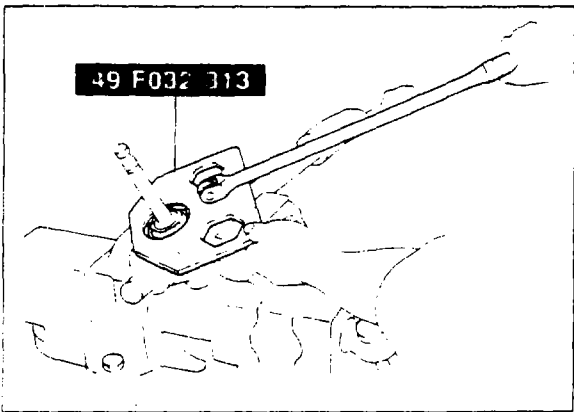

67U10A-037

Pinion

1. Remove the lock nut using **wrench** (49 F032 313).
2. Remove the rear cover with the oil seal.

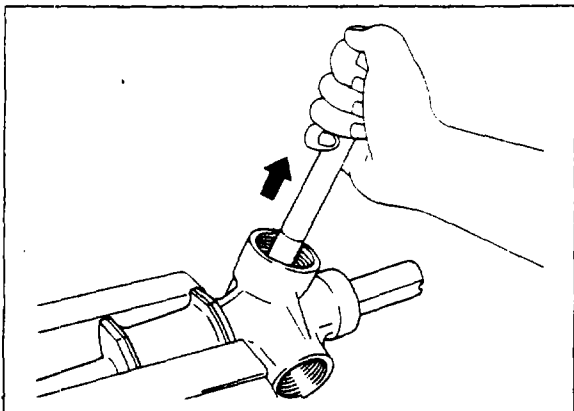

3. Grasp the serrated portion of the pinion, and pull it out.

Note

If the pinion is difficult to remove, gently tap the gear housing with a plastic hammer.

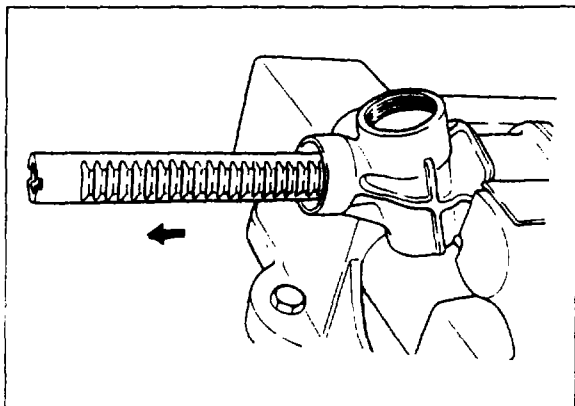

Rack

Remove the rack in the direction indicated by the arrow.

Caution

If the rack is taken out in the opposite direction, the inside surface of the rack bushing might be damaged by the edge of the rack gear.

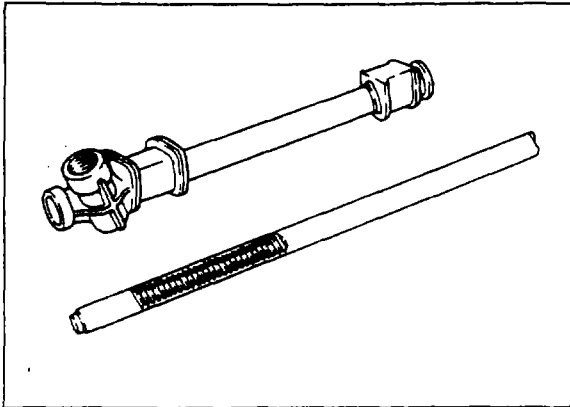

67U10A-040

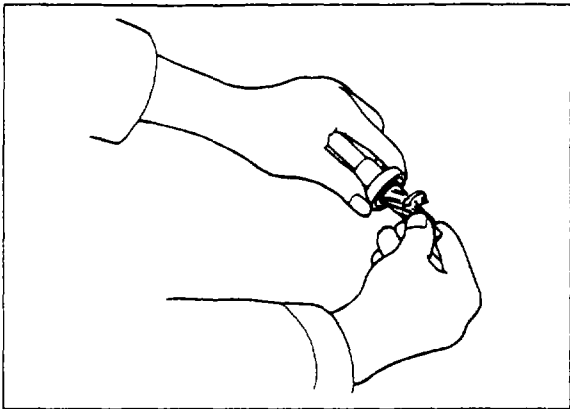

67U10A-041

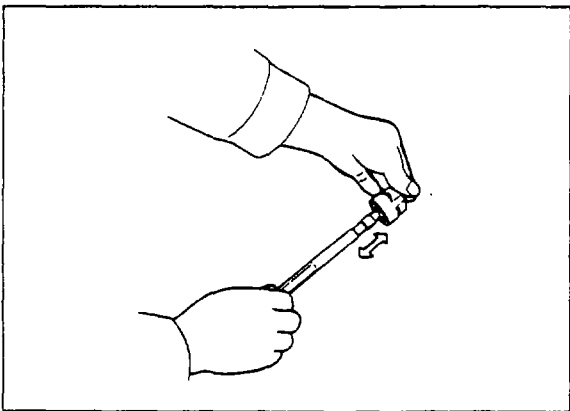

87U10A-007

INSPECTION

Check the following points, replace the part if a problem is found.

1. Cracking, damage, or deterioration of boots.
2. Cracking, worn teeth, or damage of rack and pinion.
3. Looseness, abnormal noise, or sticking of the lower bearing.

4. Worn rack bushing inside the gear housing.

5. Wear of friction surface of pressure pad.
6. Cracking or damage of gear housing.
7. Looseness or sticking of tie-rod ball-joint.
8. Bent tie-rods and/or tie-rod ends.

10A STEERING GEAR AND LINKAGE

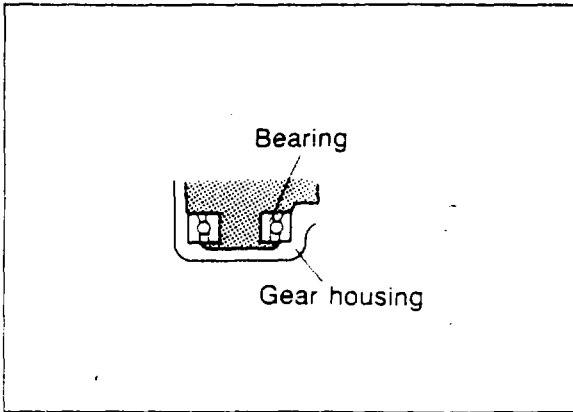

67U10A-043

ASSEMBLY

Before assembling, coat or fill the following parts with grease (lithium base, NLGI No. 2).

1. Lower bearing.

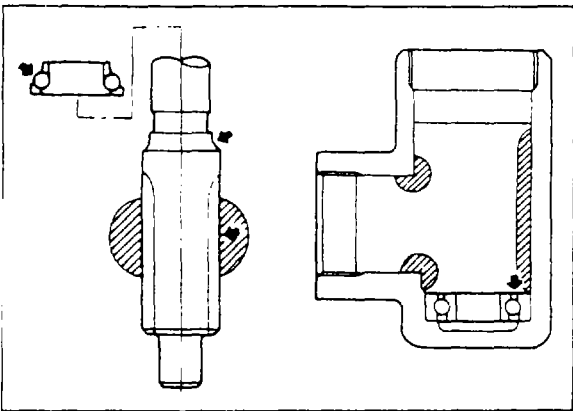

67U10A-044

2. Pinion teeth and upper bearing.
3. Inside gear housing.

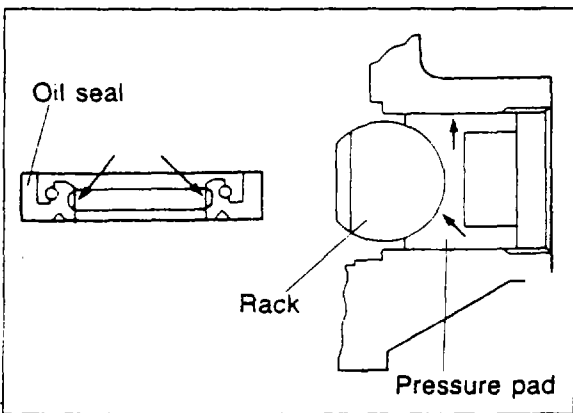

67U10A-045

4. Oil seal lip.
5. Pressure pad.

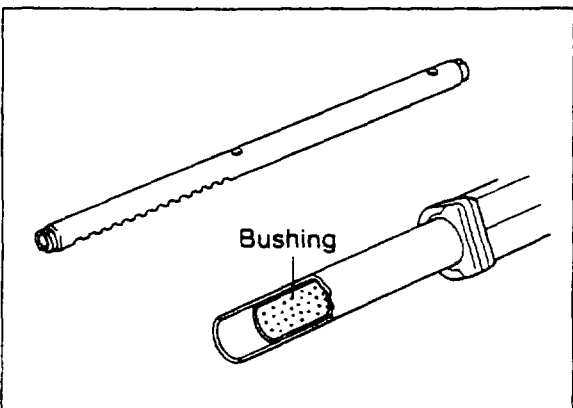

67U10A-046

6. Rack gear and outer surface of rack shaft.
7. Inner surface of housing rack bushing.
8. Tie-rod ball joint.
9. Inside left and right boots.

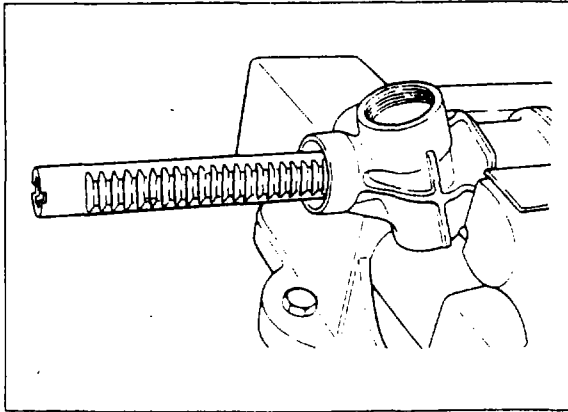

67U10A-047

Rack

Carefully install the rack in the direction of the arrow.

Caution

If the rack is installed from the opposite direction, the inner surface of the rack bushing might be damaged by the edge of the rack gear.

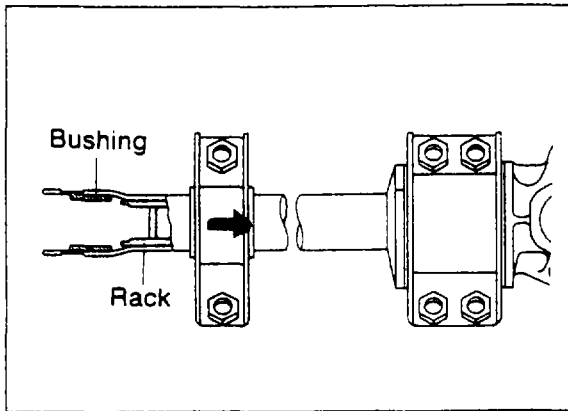

67U10A-048

Pinion

1. Insert the pinion.
2. Apply sealant to the rear cover and then install the rear cover with the oil seal
3. Move the rack further inside the housing until the rack is clear of the bushing at the opposite end of the housing to the pinion

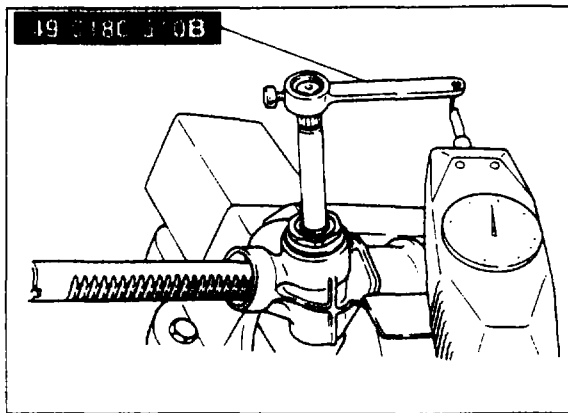

67U10A-049

4. Tighten the rear cover and adjust so that the torque of the pinion is approx. **7.1 oz (200 g)** using **preload measuring attachment (49 0180 510B)**.

Note

Before measuring the torque, rotate the pinion to the left and right so that it is seated.

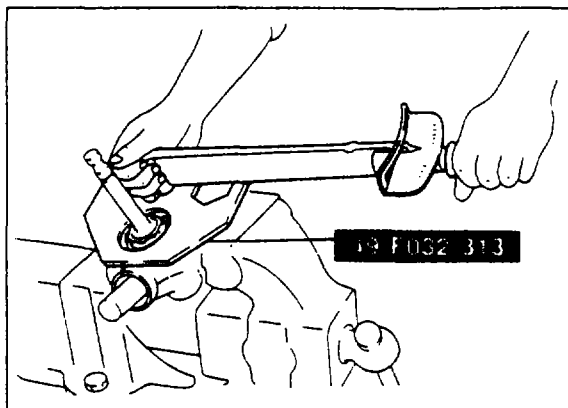

67U10A-050

5. Tighten the lock nut using **wrench (49 F032 313)**.

Tightening torque:

39—59 N·m (4—6 m·kg, 29—43 ft·lb)

6. Recheck the pinion rotation torque, if it is not within specification, readjust.

Torque: 3.5—10.6 oz (100 g—300 g)

10A STEERING GEAR AND LINKAGE

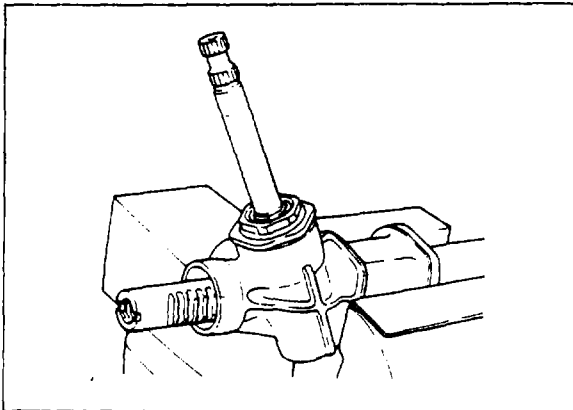

67U10A-051

Adjust Cover

1. Move the rack so that the pinion is set to the center (neutral position) of the rack gear.

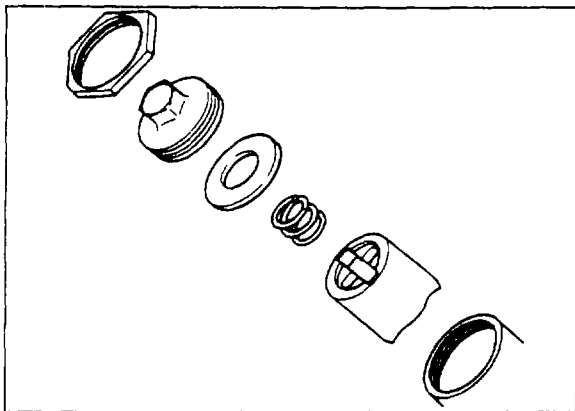

67U10A-052

2. Install the pressure pad, spring, yoke sheet adjust cover and lock nut.

Caution

- a) Install so that the pressure pad correctly contacts the rear of the rack.
- b) Apply sealant to the threads of the adjust cover.

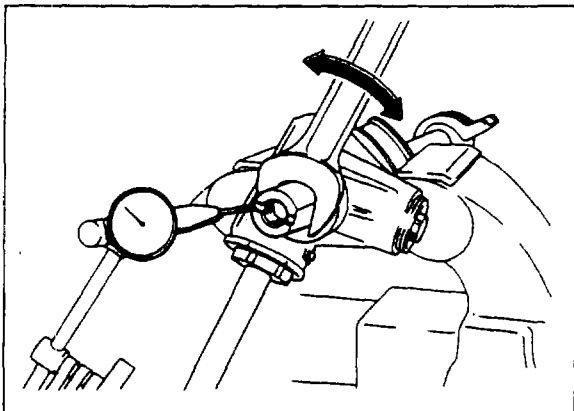

87U10A-004

3. Tighten the adjust cover and adjust so that the amount of twist of the rack is less than **0.08 mm (0.0031 in)**.

Twist torque: 6.87 N·m (0.7 m·kg, 5.1 ft·lb)

4. Tighten the lock nut using **wrench (49 F032 313)**.

Tightening torque:

39—59 N·m (4—6 m·kg, 29—43 ft·lb)

5. Recheck the amount of twist of the rack, if it is not within specification, readjust.

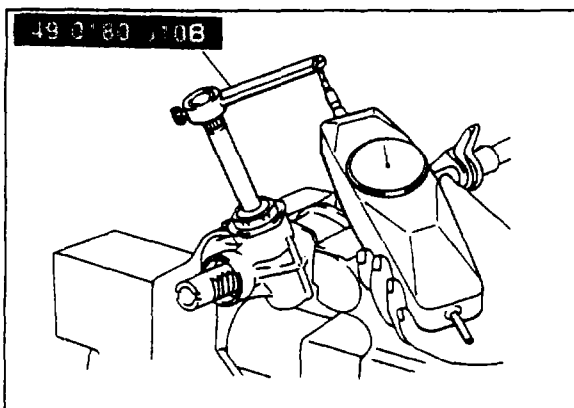

67U10A-054

6. Measure the pinion torque.
Measure the pinion torque using the **pre-load attachment (49 0180 510B)**.

Pinion torque:

Neutral position $\pm 90^\circ$

Spring gauge reading:

35—53 oz (1,200—1,700 g)

Any other position

Spring gauge reading:

less than 45.9 oz (1,300 g)

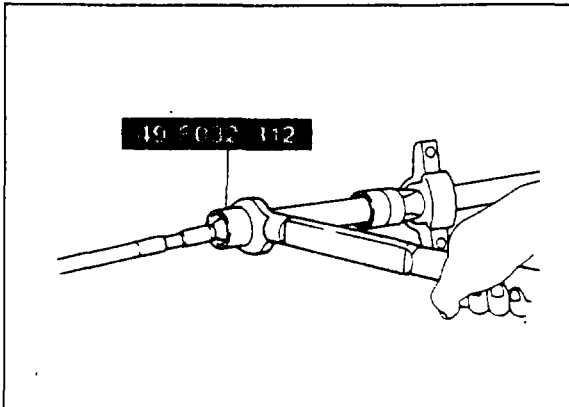

87U10A-005

Tie-rod

1. secure the rack gear in a vise.
2. Tighten the left and right tie-rods, using **wrench** (49 F032 312).

Tightening torque:

78—108 N-m (8—11 m-kg, 58—80 ft-lb)

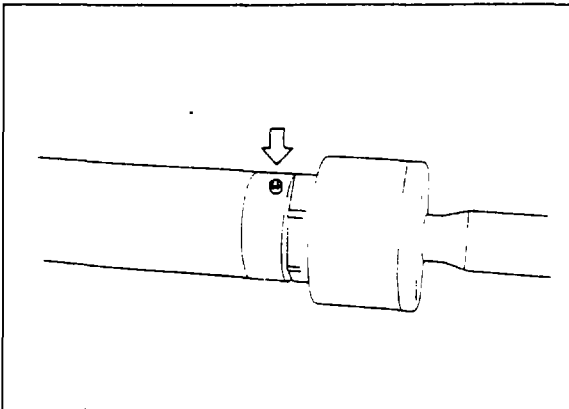

67U10A-056

2. Insert new pins.

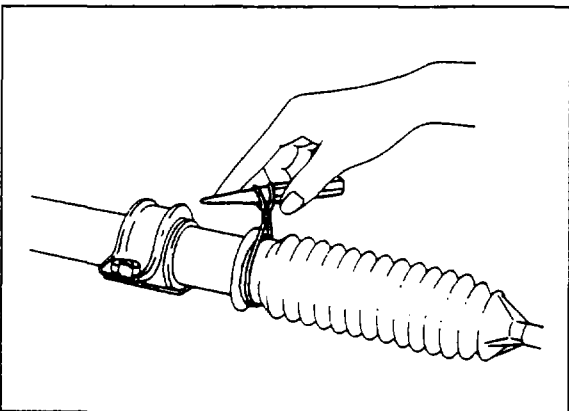

67U10A-057

Boots

Install the boot. Wrap a new wire around the boot two times and then twist it 4 or 4.5 times.

Note

- 1) Check that the boot is not twisted or dented.
- 2) A rubber spacer is used on the right side. Do not forget to install it.

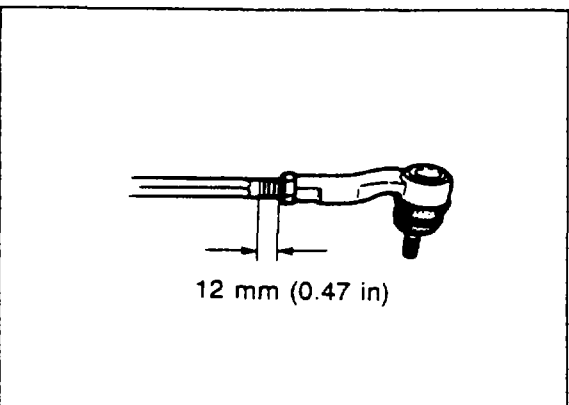

67U10A-058

Tie-rod Ends

Install the tie-rod ends and align with the marks made before disassembly.

Caution

The tie-rod ends are to be screwed on so about 12 mm (0.47 in) of threads remain exposed.

