

1989 Mazda RX-7 Factory Service Manual

This Online/PC version of the Manual has been brought to you by “Scott 89t2” and www.1300cc.com

Thanks to those who are hosting it for me.



Some parts of the manual may be hard to read or see on the screen, but if you print the pages out it's perfect. Well except for the crookedness ☺.

***Terms of Use:** This online/PC copy of the manual is only to be used and in your possession if you already own the printed version. It is for backup purposes only in case yours (or part of) is lost or damaged. If you downloaded this manual by mistake, Please Remove it from your possession. I also take no responsibility for what you do to yourself or your car while you use this manual.

ENGINE

INDEX	C- 2
OUTLINE	C- 3
SPECIFICATIONS	C- 3
TROUBLESHOOTING GUIDE	C- 3
ENGINE TUNE-UP PROCEDURE	C- 5
DRIVE BELT.....	C- 5
COMPRESSION	C- 6
ON-VEHICLE MAINTENANCE	C- 8
REAR OIL SEAL	C- 8
REMOVAL	C-11
REMOVAL (TURBO).....	C-11
REMOVAL (NON-TURBO).....	C-15
ENGINE STAND INSTALLATION	C-19
INSTALLATION.....	C-19
DISASSEMBLY	C-21
AUXILIARY PARTS (TURBO)	C-22
AUXILIARY PARTS (NON-TURBO).....	C-25
MAIN PARTS.....	C-28
CLEANING	C-37
INSPECTION AND REPAIR	C-39
ASSEMBLY	C-47
MAIN PARTS.....	C-48
AUXILIARY PARTS (TURBO)	C-64
AUXILIARY PARTS (NON-TURBO).....	C-72
ENGINE STAND REMOVAL	C-79
REMOVAL	C-79
INSTALLATION	C-80
INSTALLATION (TURBO).....	C-80
INSTALLATION (NON-TURBO)	C-84

INDEX

INTAKE MANIFOLD TIGHTENING TORQUE
 19—25 N·m (1.9—2.6 m·kg, 14—19 ft·lb)

COMPRESSION INSPECTION, PAGE C-6
 MINIMUM: 589 kPa (6.0 kg/cm², 85 psi)—250 rpm

ENGINE OIL INSPECTION SERVICE, SECTION D

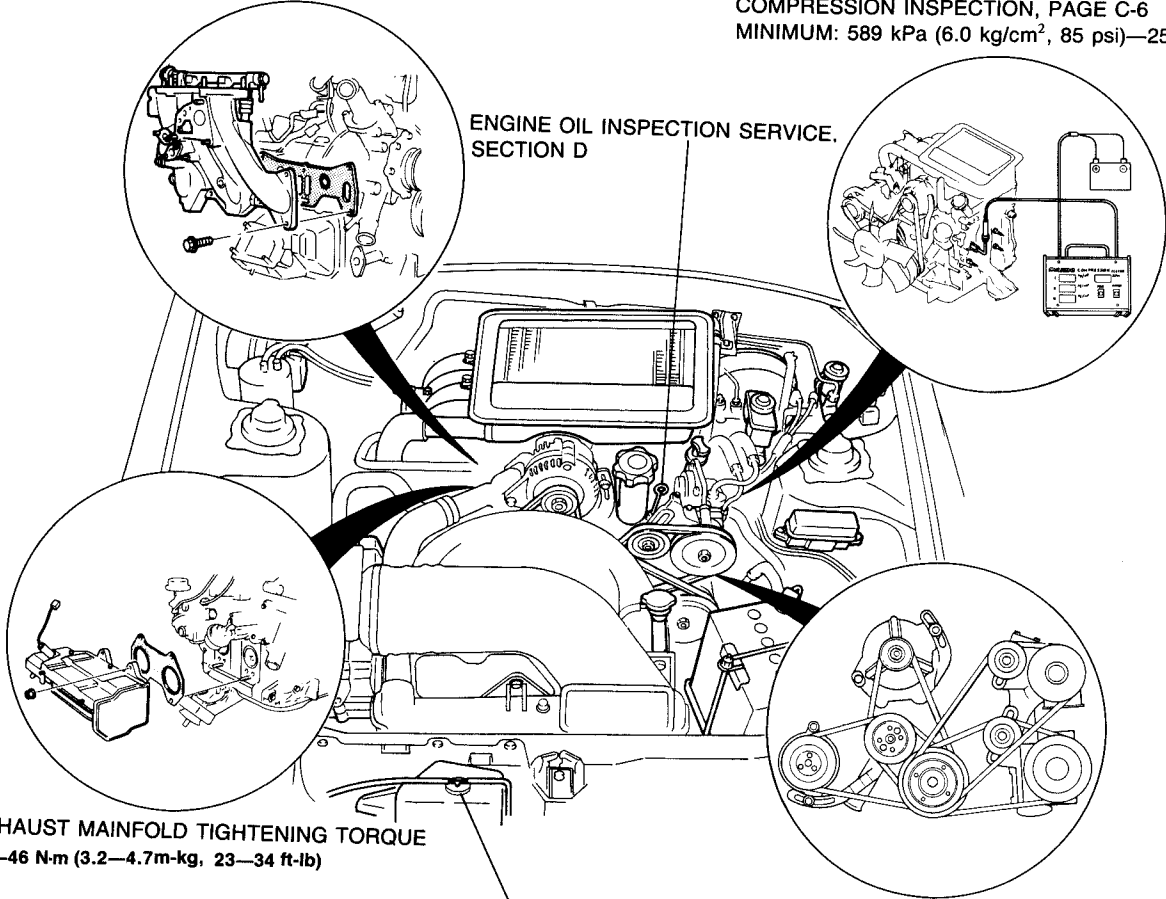

EXHAUST MAINFOLD TIGHTENING TORQUE
 31—46 N·m (3.2—4.7m·kg, 23—34 ft·lb)

DRIVE BELT ADJUSTING, PAGE C-5

ENGINE COOLANT INSPECTION SERVICE, SECTION E

DEFLECTION

mm (in)

DRIVE BELT		NEW	USED
ALTERNATOR		12.0—15.0 (0.47—0.59)	14.0—17.0 (0.55—0.67)
P/S OIL PUMP		11.0—13.0 (0.43—0.51)	14.0—16.0 (0.55—0.63)
A/C COMPRESSOR		6.0—8.0 (0.24—0.31)	8.0—9.0 (0.31—0.35)
AIR PUMP	TURBO	9.0—11.0 (0.35—0.43)	11.0—13.0 (0.43—0.51)
	NON-TURBO	9.0—11.0 (0.35—0.43)	11.0—13.0 (0.43—0.51)

97U0CX-002

1. Engine

- Removal page C-11
- Disassembly page C-21
- Inspection and Repair page C-39
- Assembly page C-47
- Installation page C-80

OUTLINE

SPECIFICATIONS

Items			Model	Turbo	Non-Turbo
Engine type				Rotary engine	
Displacement			cc (cu in)	654x2 (40.0x2)	
Number of cylinders and arrangement				2 rotors, longitudinal	
Combustion chamber type				Bathtub	
Compression ratio				9.0:1	9.7:1
Air induction				4 port induction	6 port induction
Port timing	Intake	Open	Primary	45° ATDC	32° ATDC
			Secondary	32° ATDC	
			Auxiliary	—	45° ATDC
	Close	Primary	50° ABDC	40° ABDC	
		Secondary	50° ABDC	30° ABDC	
		Auxiliary	—	80° ABDC	
Exhaust	Open	75° BBDC			
	Close	48° ATDC			
Fuel supply system				EGI	
Ignition timing			Trailing	20° ± 2° ATDC (RED)	
			Leading	5° ± 1° ATDC (YELLOW)	
Idle speed			rpm	750 ± 25	

97U0CX-003

TROUBLESHOOTING GUIDE

Problem	Possible cause	Action	Page
Difficult starting	Insufficient compression Deformation or abnormal wear of side housing Deformation or abnormal wear of rotor housing Wear of rotor grooves Deformation of or loose rotor seals Worn or weak rotor seal springs	Replace Replace Replace Replace Replace	C-39 C-42 C-44, 45 C-44, 45 —
	Malfunction of metering oil pump		Section D
	Malfunction of fuel system		Section F1,F2
	Malfunction of electrical system		Section G
Poor idling	Insufficient compression Deformation or abnormal wear of side housing Deformation or abnormal wear of rotor housing Wear of rotor grooves Deformation of or loose rotor seals Worn or weak rotor seal springs	Replace Replace Replace Replace Replace	C-39 C-42 C-44, 45 C-44, 45 —
	Malfunction of fuel system		Section F1,F2
	Malfunction of ignition system		Section G

97U0CX-004

C TROUBLESHOOTING GUIDE

Problem	Possible cause	Action	Page
Insufficient power	Insufficient compression Deformation or abnormal wear of side housing Deformation or abnormal wear of rotor housing Wear of rotor grooves Deformation or loose rotor seals Worn or weak rotor seal springs	Replace Replace Replace Replace	C-39 C-42 C-44, 45 C-44, 45
	Malfunction of fuel system		Section F1,F2
	Malfunction of ignition system		Section G
Abnormal combustion	Malfunction in combustion chamber Carbon accumulation	Remove and clean	C-37
	Malfunction of fuel system		Section F1,F2
	Malfunction of ignition system		Section G
Excessive oil consumption	Leakage into combustion chamber Deformation or abnormal wear of side housing Malfunction of rotor (blow holes) Scratched or burred rotor land Malfunction of oil seal (incorrect angle)	Replace Replace Replace Replace	C-39 C-42 C-42 C-43
	Leakage into coolant passages Deformed rotor housing Malfunction of sealing rubber	Replace Replace	C-42 —
	Leakage to outside of engine		Section D
	Malfunction of lubrication system		Section D
Engine noise	Rotor seal noise Malfunction of rotor seals Malfunction of housing Malfunction of seal spring Malfunction of metering oil pump	Replace Replace Replace	C-44 C-39, 42 C-44 Section D
	Knocking noise Accumulation of carbon	Remove and clean	C-37
	Hitting noise Malfunction of main bearing or rotor bearing Excessive end play Foreign matter in internal gear or stationary gear or malfunction of gear	Replace Adjust Replace	C-41, 43 C-60 C-40
	Other Malfunction of water pump bearing Loose drive belt Malfunction of alternator bearing Exhaust gas leakage Malfunction of fuel system	Adjust	Section E C- 5 Section G Section F1,F2 Section F1,F2

97U0CX-005

ENGINE TUNE-UP PROCEDURE

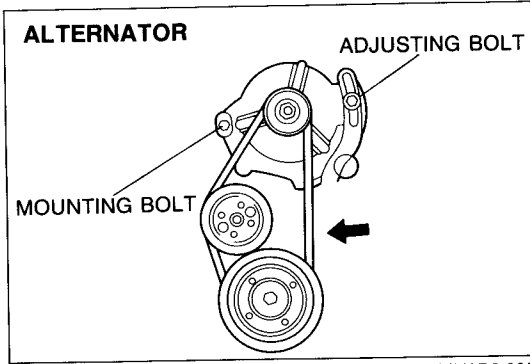

9MU0B2-005

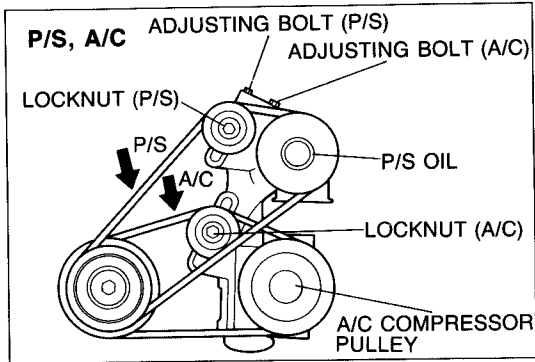

97U0CX-006

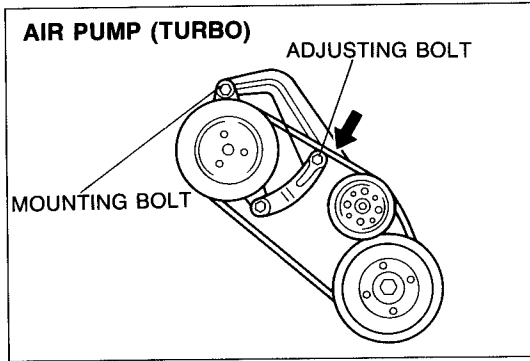

97U0CX-007

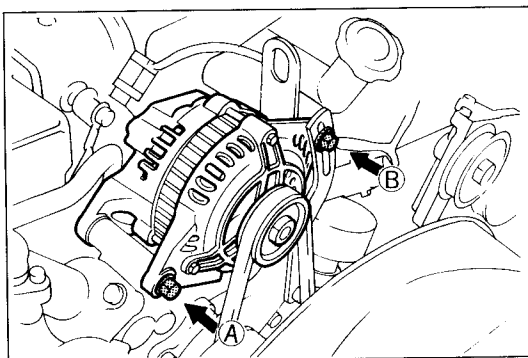
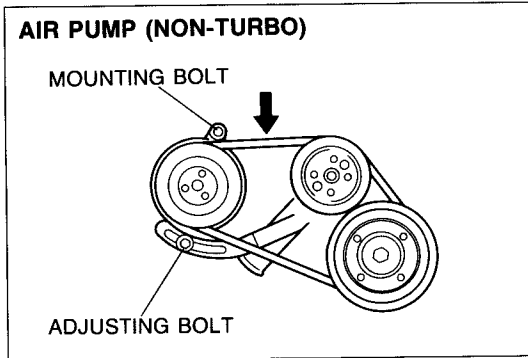

97U0CX-008

DRIVE BELT

1. Check the drive belts for wear, cracks, or fraying; replace if necessary.
2. Check the drive belt deflection by applying moderate pressure (**98 N, 10 kg, 22 lb**) midway between the pulleys. Adjust if necessary.

Deflection

mm (in)

Drive belt		New	Used
Alternator		12.0—15.0 (0.47—0.59)	14.0—17.0 (0.55—0.67)
P/S oil pump		11.0—13.0 (0.43—0.51)	14.0—16.0 (0.55—0.63)
A/C compressor		6.0—8.0 (0.24—0.31)	8.0—9.0 (0.31—0.35)
Air pump	Turbo	9.0—11.0 (0.35—0.43)	11.0—13.0 (0.43—0.51)
	Non-turbo	9.0—11.0 (0.35—0.43)	11.0—13.0 (0.43—0.51)

3. Check the drive belt tension with the tension gauge.

Tension

N (kg, lb)

Drive belt		New	Used
Alternator		245—343 (25—35, 55.0—77.0)	196—294 (20—30, 44.0—66.0)
P/S oil pump		392—491 (40—50, 88.0—110.0)	284—353 (29—36, 63.8—79.2)
A/C compressor		392—540 (40—55, 88.0—121.0)	284—363 (29—37, 63.8—81.4)
Air pump	Turbo	275—373 (28—38, 61.6—83.6)	177—275 (18—28, 39.6—61.6)
	Non-turbo	275—373 (28—38, 61.6—83.6)	177—275 (18—28, 39.6—61.6)

Adjustment

- (1) Alternator belt
If necessary, loosen the alternator bolts and adjust the belt deflection by turning the adjusting bolt.

Tightening torque:

- Bolt A: 37—52 N·m (3.8—5.3 m·kg, 27—38 ft·lb)**
Bolt B: 19—25 N·m (1.9—2.6 m·kg, 14—19 ft·lb)

C ENGINE TUNE-UP PROCEDURE, COMPRESSION

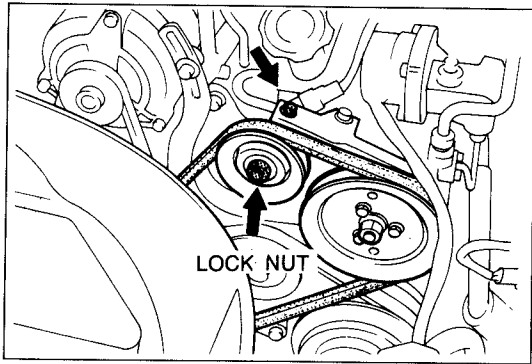

97U0CX-009

- (2) P/S oil pump belt
If necessary, loosen the locknut and adjust the belt deflection by turning the adjusting bolt.

Tightening torque:
36—54 N·m (3.7—5.5 m·kg, 27—40 ft·lb)

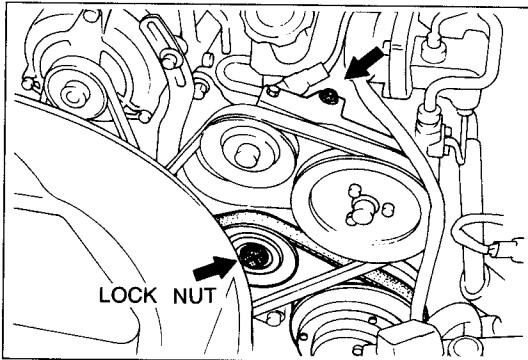

97U0CX-010

- (3) A/C Compressor belt
If necessary, loosen the locknut and adjust the belt deflection by turning the adjusting bolt.

Tightening torque:
36—54 N·m (3.7—5.5 m·kg, 27—40 ft·lb)

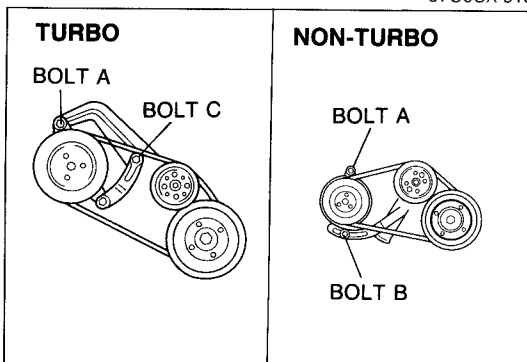

97U0CX-011

- (4) Air pump belt
If necessary, loosen the air pump bolts and adjust the belt deflection by turning the adjusting bolt.

Tightening torque:
Bolt A: 16—23 N·m (1.6—2.3 m·kg, 12—17 ft·lb)
Bolt B: 24—30 N·m (2.4—3.1 m·kg, 17—22 ft·lb)
Bolt C: 19—25 N·m (1.9—2.6 m·kg, 14—19 ft·lb)

COMPRESSION

If the engine exhibits low power, poor fuel economy, or poor idle, check the following:

1. Ignition system (Refer to Section G.)
2. Compression
3. Fuel system (Refer to Section F1, F2.)

COMPRESSION PREPARATION SST

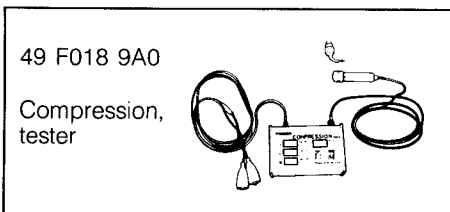

97U0CX-013

97U0CX-012

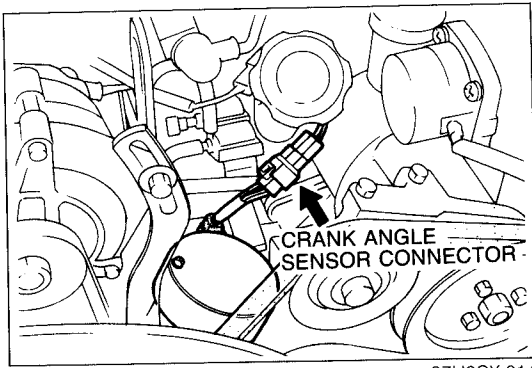

97U0CX-014

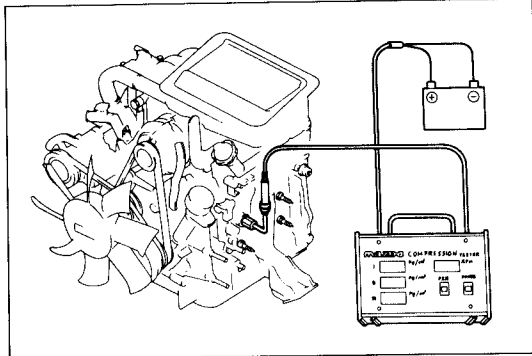

97U0CX-015

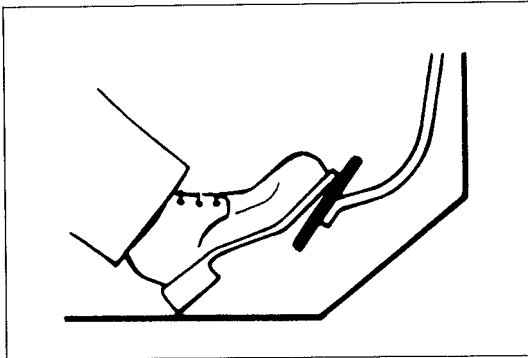

97U0CX-016

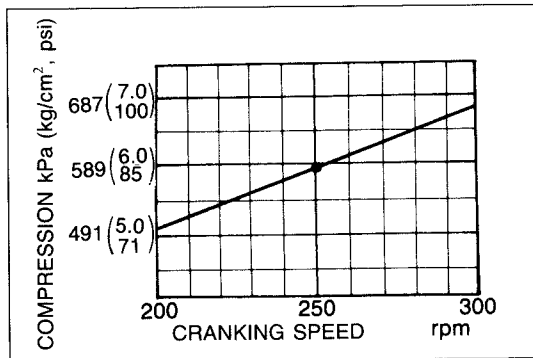

97U0CX-017

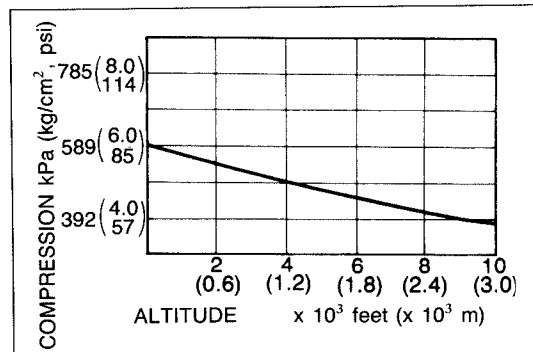

97U0CX-018

1. Check that the battery is fully charged. Recharge it if necessary.
2. Warm up the engine to the normal operating temperature.
3. Turn it off for about 10 minutes to allow the exhaust manifold to cool.
4. Remove the front and rear trailing-side spark plugs.
5. Disconnect the crank angle sensor connector.

6. Connect the **SST** to the front rotor housing and the battery.
7. Fully depress the accelerator pedal and crank the engine for 5 to 10 seconds.
8. Make a note of the compression of the three combustion chambers and cranking speed.

Compression:

589 kPa (6.0 kg/cm², 85 psi) — 250 rpm

Differential limit of chambers:

147 kPa (1.5 kg/cm², 21 psi) — 250 rpm

Note

- 1) If pressure below 294 kPa (3.0 kg/cm², 43 psi) exists in one or two chambers of a rotor, the tester indicates one correct measurement and two 00.0 readings.
- 2) If three chamber pressure are below 294 kPa (3.0 kg/cm², 43 psi), the tester indicates three 00.0 readings.
- 3) In both two cases, the cranking speed readings are all 00.0.

9. Check the rear chambers with the same procedure.

Note

Compensate for the compression values if they are measured at cranking speeds different than standard or if they are measured at a high altitude.

Cranking speed compensation



Compensate for the cranking speed.

Altitude compensation

Compensate for the altitude.

ON-VEHICLE MAINTENANCE

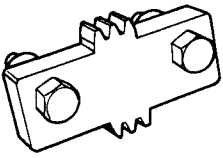
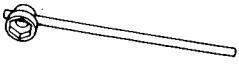
REAR OIL SEAL PREPARATION SST

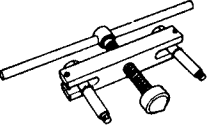
49 F011 101 Ring gear brake 	49 0820 035 Flywheel box wrench 	49 1881 055 Counter weight stopper 
49 0839 305A Counter weight puller 	97U0CX-019	

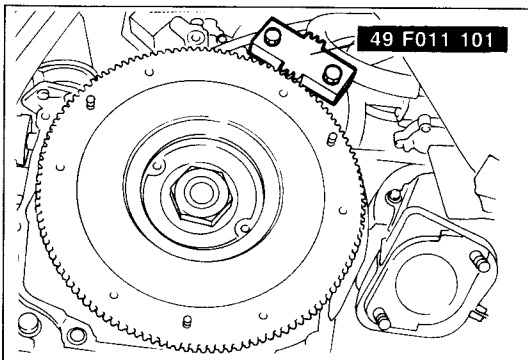

97U0CX-020

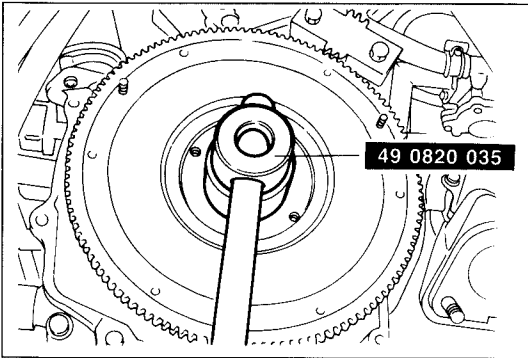

97U0CX-021

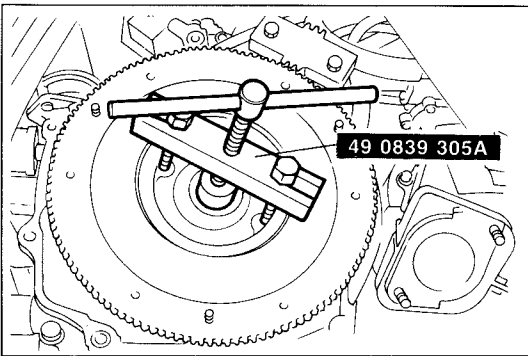

97U0CX-022

Removal

1. Disconnect the negative battery cable.
2. Drain the engine oil.
3. Remove the manual transmission. (Refer to Section J.)
Remove the automatic transmission. (Refer to Section K.)
4. Remove the clutch cover and clutch disc.
(Refer to Section H.)

(M/T)

5. Install the **SST** against the flywheel.

Caution

Place a rag between the SST and the vacuum pipes to protect the pipes.

6. Remove the locknut with the **SST**.

7. Remove the flywheel with the **SST**.
8. Remove the key.

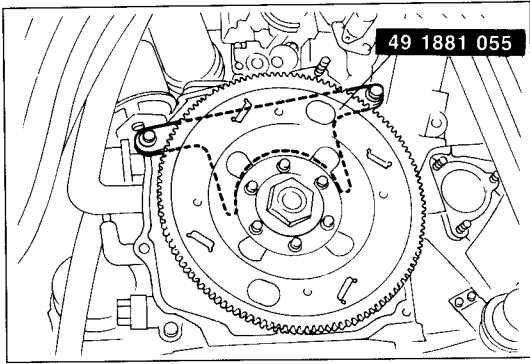

97U0CX-023

- (A/T)
5. Install the **SST** against the counter weight.

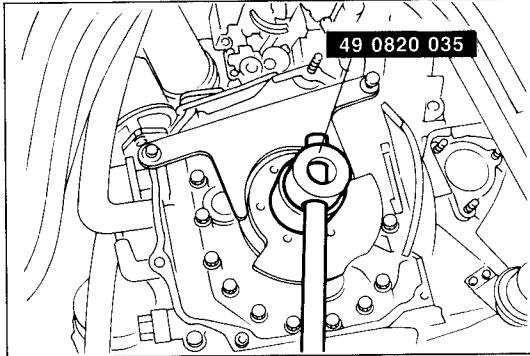

97U0CX-024

6. Remove the back plate and drive plate.
7. Remove the locknut with the **SST**.

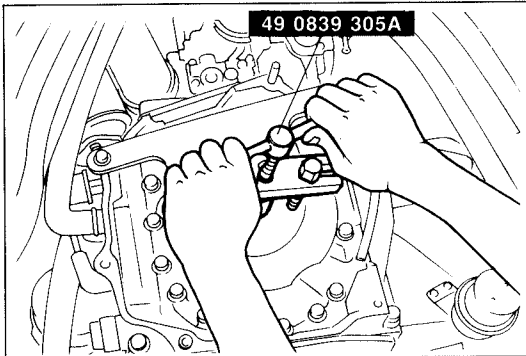

97U0CX-025

8. Remove the counter weight with the **SST**.

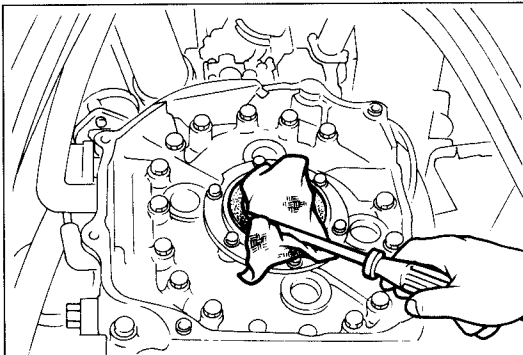

97U0CX-026

- (M/T and A/T)
9. Remove the oil seal with a screwdriver and a rag.

Installation

Install in the reverse order of removal referring to the **Installation Note**.

Installation note

Rear oil seal

1. Apply engine oil to the seal lip.
2. Fit the oil seal onto the stationary gear.
3. Tap the oil seal in evenly using a suitable pipe.

Oil seal outer diameter: 94mm (3.70 in)

Caution

The oil seal must be tapped in until it is flush with the edge of the rear cover.

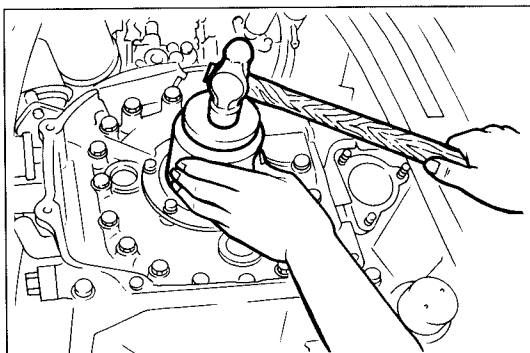

97U0CX-027

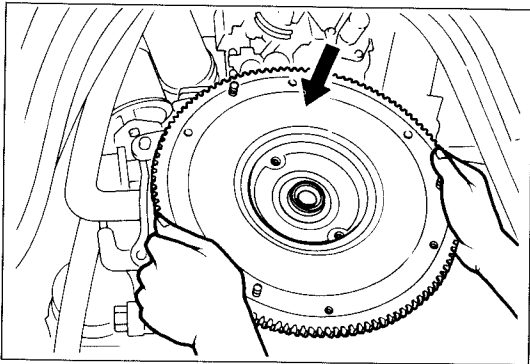

97U0CX-028

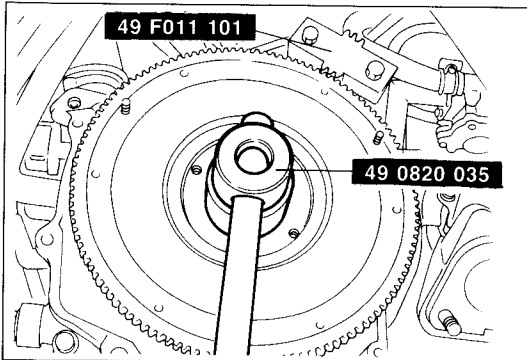

97U0CX-029

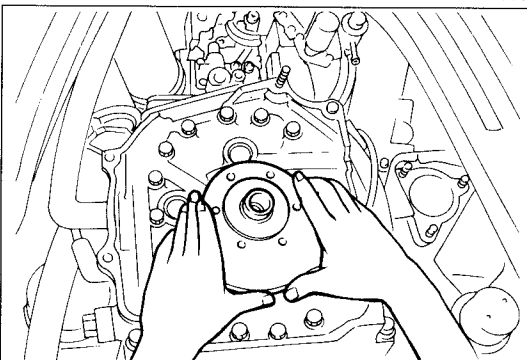

97U0CX-030

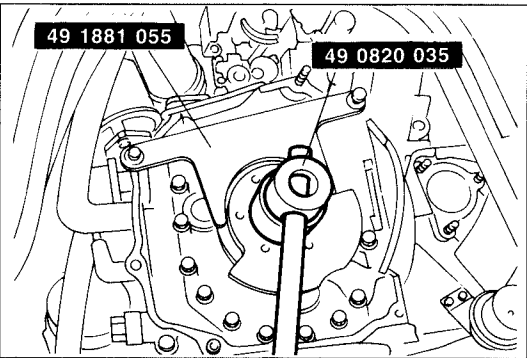

97U0CX-031

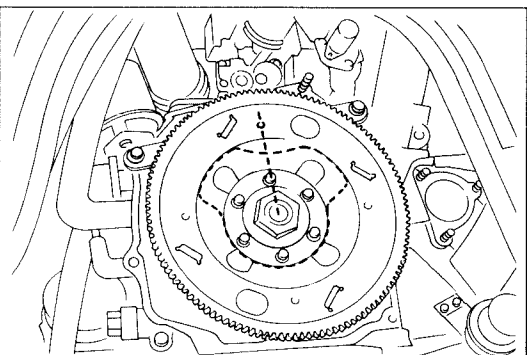

97U0CX-032

Flywheel (M/T)

1. Fit the key to the eccentric shaft.
2. Install the flywheel to the eccentric shaft.
3. Apply thread locking compound to the eccentric shaft threads.
4. Apply sealant to the contact surface of the locknut.

5. Install the locknut and tighten it with the **SST**.

Tightening torque:

392—491 N·m (40—50 m·kg, 289—362 ft·lb)

Caution

Place a rag between the SST and the vacuum pipes to protect pipes.

Drive plate (A/T)

1. Fit the key to the eccentric shaft.
2. Install the counter weight to the eccentric shaft.
3. Apply thread locking compound to the eccentric shaft threads.
4. Apply sealant to the contact surface of the locknut.

5. Install the locknut and tighten it with the **SST**.

Tightening torque:

392—491 N·m (40—50 m·kg, 289—362 ft·lb)

6. Install the drive plate so that the holes in the drive plate and counter weight are positioned as shown in the figure. Install the back plate and tighten.

Tightening torque:

43—61 N·m (4.4—6.2 m·kg, 32—45 ft·lb)

Steps After Installation

1. Add engine oil to the specified levels.
2. Connect the negative battery cable.
3. Start the engine and do the following:
 - (1) Check for leakage of engine oil.
 - (2) Perform engine adjustments if necessary.
 - (3) Recheck the oil levels.

C REMOVAL (TURBO)

1. Air intake pipe
2. Air cleaner assembly
3. Battery and box
4. Cooling fan
5. Upper and lower radiator hose
6. Relief silencer hose
7. Heater return hose and pipe
8. Coolant level sensor connector
9. Radiator and cowling
10. Intercooler
11. Accelerator cable
12. Cruise control cable (if equipped)
13. Brake vacuum hose
14. Boost sensor vacuum hose
15. Split air pipe
16. Oxygen sensor connector
17. Insulator covers
18. Engine harness connectors

STEP 2

97UOCX-035

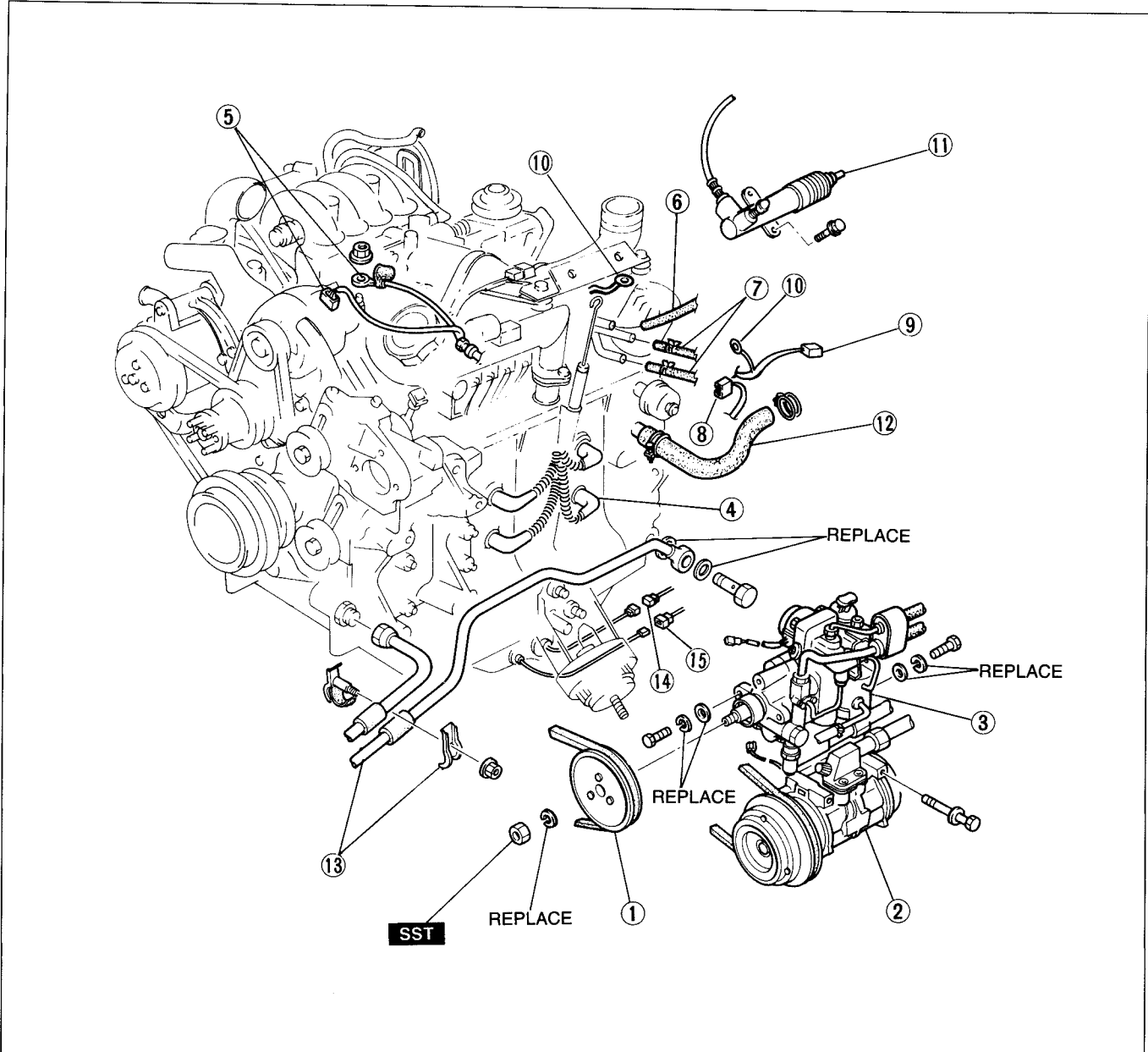

1. P/S oil pump pulley and drive belt
2. A/C compressor and drive belt
3. P/S oil pump
4. High-tension leads
5. Alternator connector
6. Canister hose
7. Fuel hoses
8. Oil pressure gauge connector
9. Heat gauge unit connector
10. Engine ground
11. Clutch release cylinder
12. Heater hose
13. Oil cooler pipes and bracket
14. Oil level sensor connector
15. Sub-zero sensor connector

97UOCX-036

STEP 3

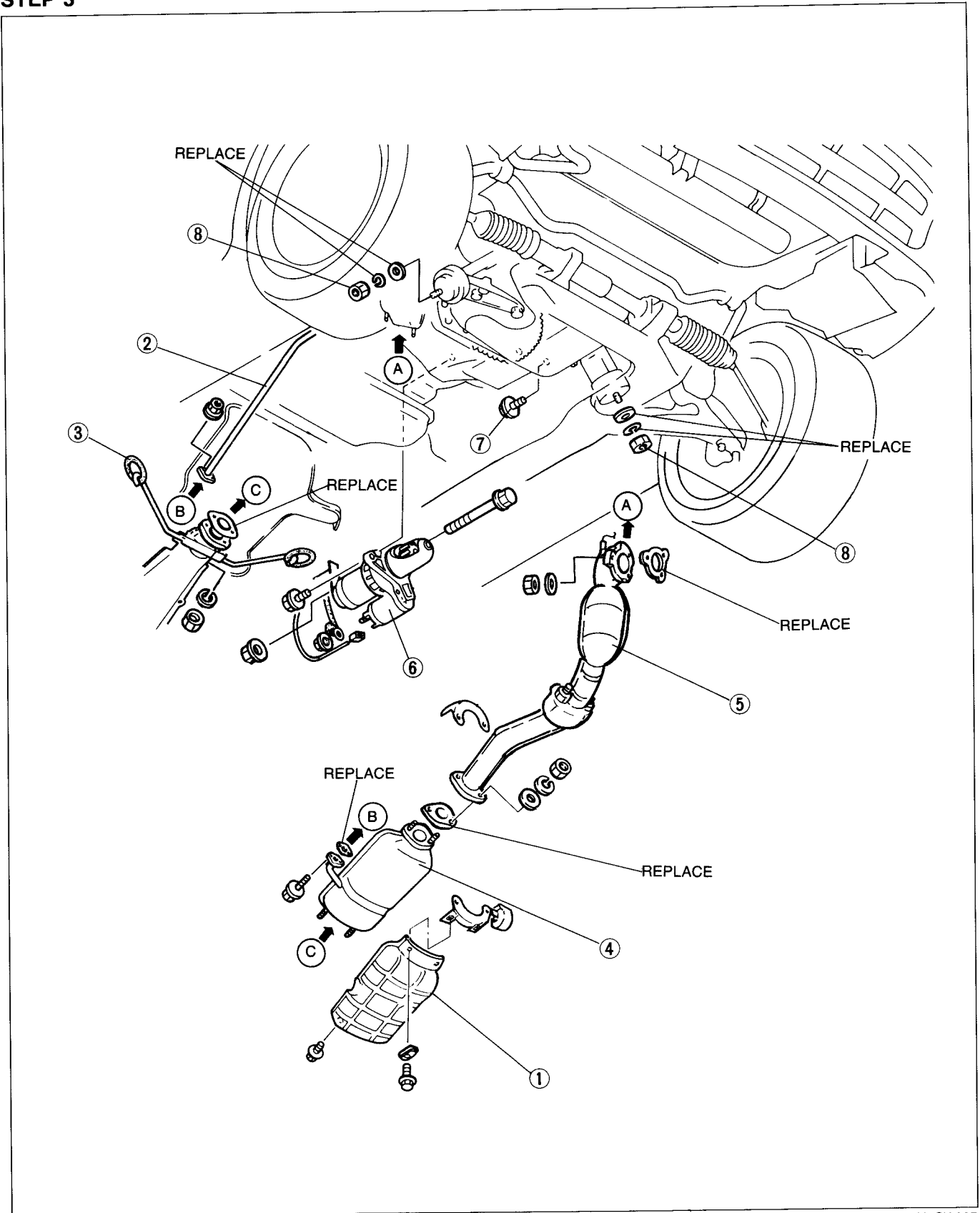

97U0CX-037

- 1. Catalytic converter insulator
- 2. Split air pipe
- 3. Exhaust pipe bracket
- 4. Catalytic converter

- 5. Front exhaust pipe and front converter
- 6. Starter
- 7. Transmission bolts
- 8. Engine mount nuts

C REMOVAL (TURBO)

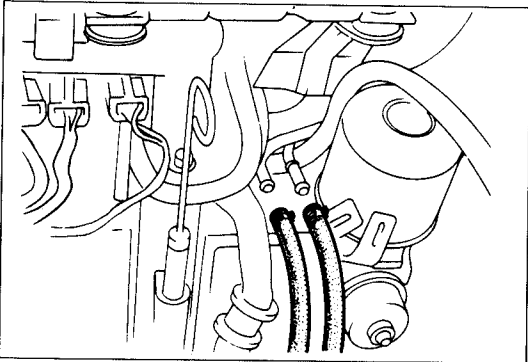

76G01A-118

Removal Note Fuel hose

Warning

- a) Cover the hose with a rag because fuel will spray out when disconnecting.
- b) Keep sparks and open flame away from the fuel area.

Plug the disconnected hoses to avoid fuel leakage.

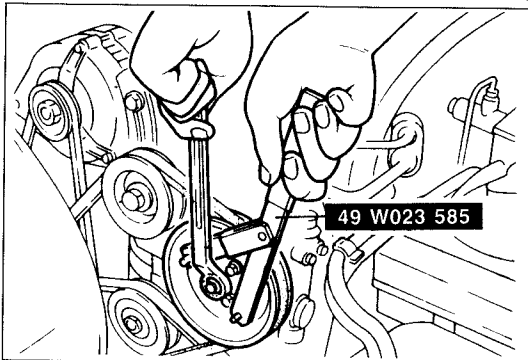

9MU0B2-250

P/S oil pump pulley

Remove the P/S oil pump pulley with the **SST**.

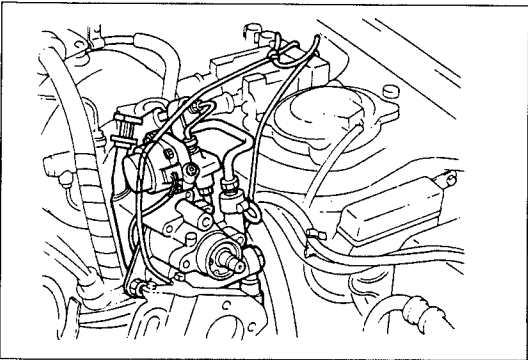

9MU0B2-251

P/S oil pump, A/C oil compressor

Remove the P/S pump and A/C compressor with the hoses still connected to them; secure the pump and compressor as shown in the figure.

**REMOVAL (NON-TURBO)
PREPARATION
SST**

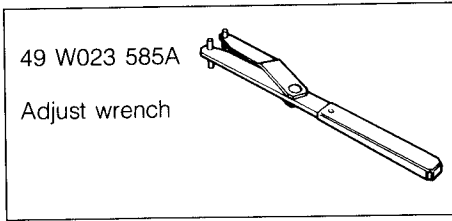

97U0CX-038

Warning: Release the fuel pressure. (Refer to Section F1.)

1. Disconnect the negative battery cable.
2. Remove the under cover.
3. Drain the engine oil and coolant.
4. Remove in the sequence shown in the figure referring to the **Removal Note**.

STEP 1

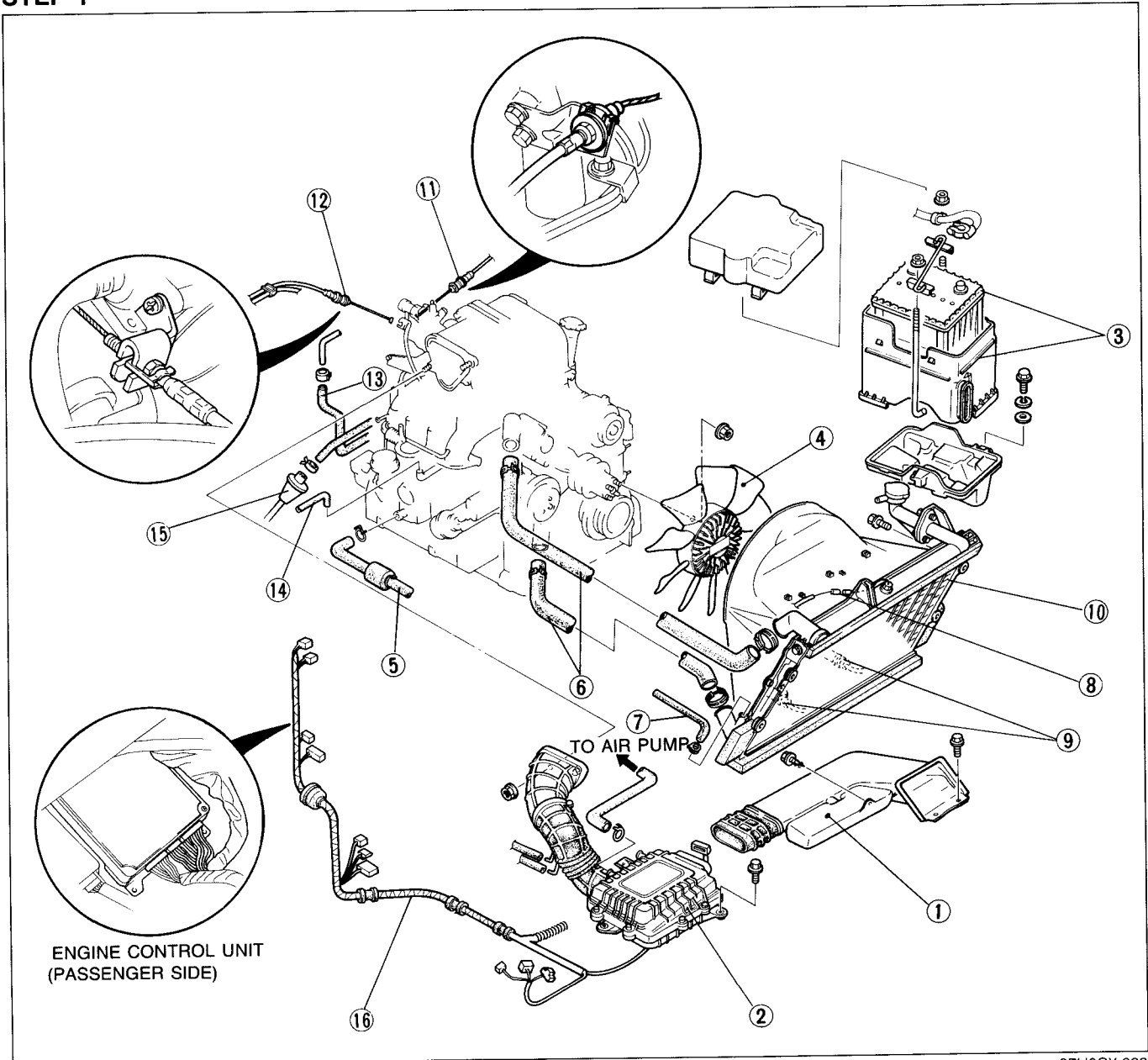

C REMOVAL (NON-TURBO)

1. Air intake pipe
2. Air cleaner assembly
3. Battery and box
4. Cooling fan
5. Relief silencer hose
6. Upper and lower radiator hose
7. Heater return hose
8. Coolant level sensor connector
9. ATF hoses
10. Radiator and cowl
11. Accelerator cable
12. Cruise control cable (if equipped) and vacuum hose
13. Brake vacuum hose
14. Boost sensor vacuum hose
15. Split air pipe
16. Engine harness connectors

STEP 2

97U0CX-040

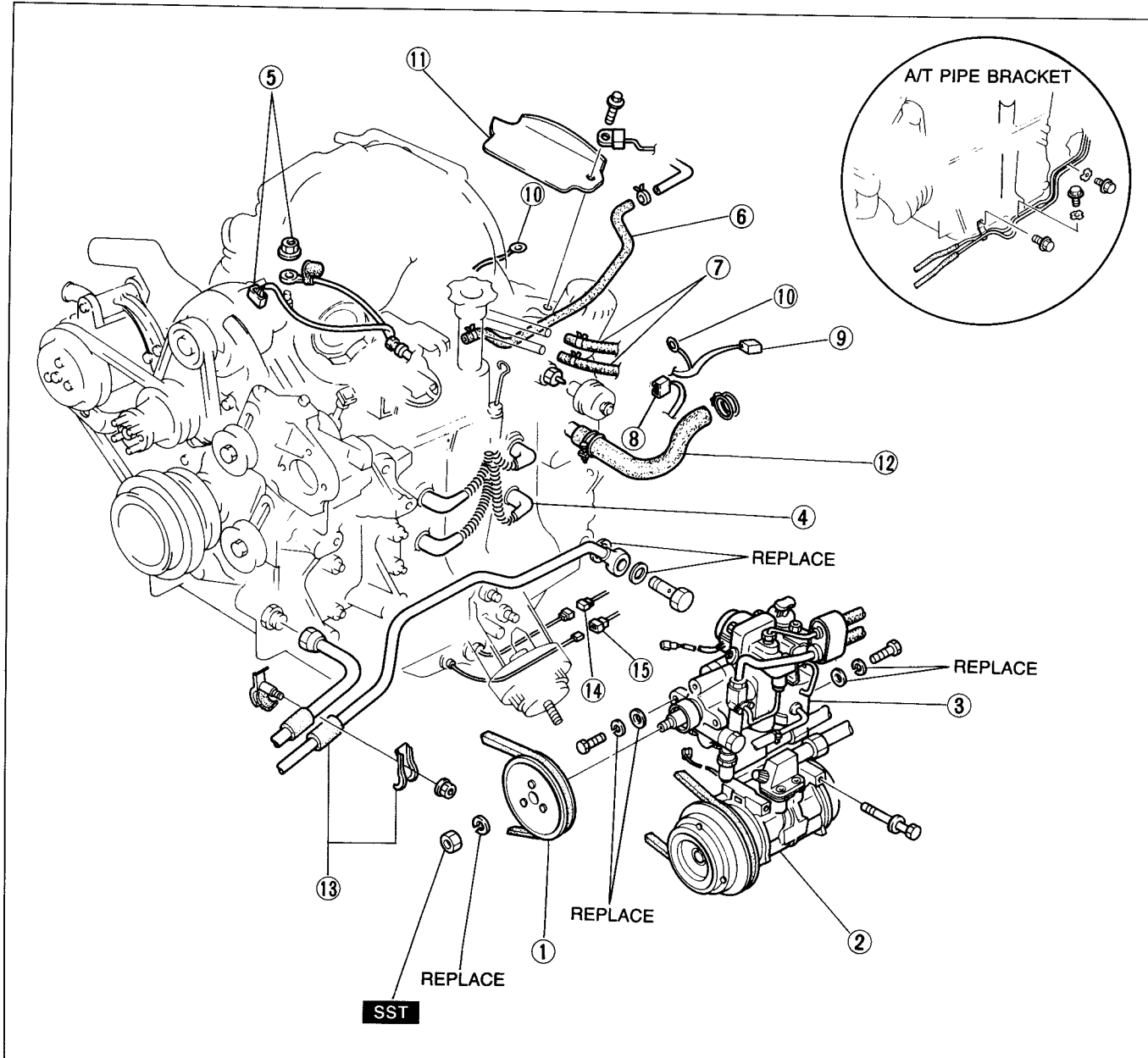

97U0CX-041

1. P/S oil pump pulley and drive belt
2. A/C compressor and drive belt
3. P/S oil pump
4. High-tension leads
5. Alternator connector
6. Canister hose
7. Fuel hoses
8. Oil pressure gauge connector
9. Heat gauge unit connector
10. Engine ground
11. Dust cover
12. Heater hose
13. Oil cooler pipes and bracket
14. Oil level sensor connector
15. Sub-zero sensor connector

STEP 3

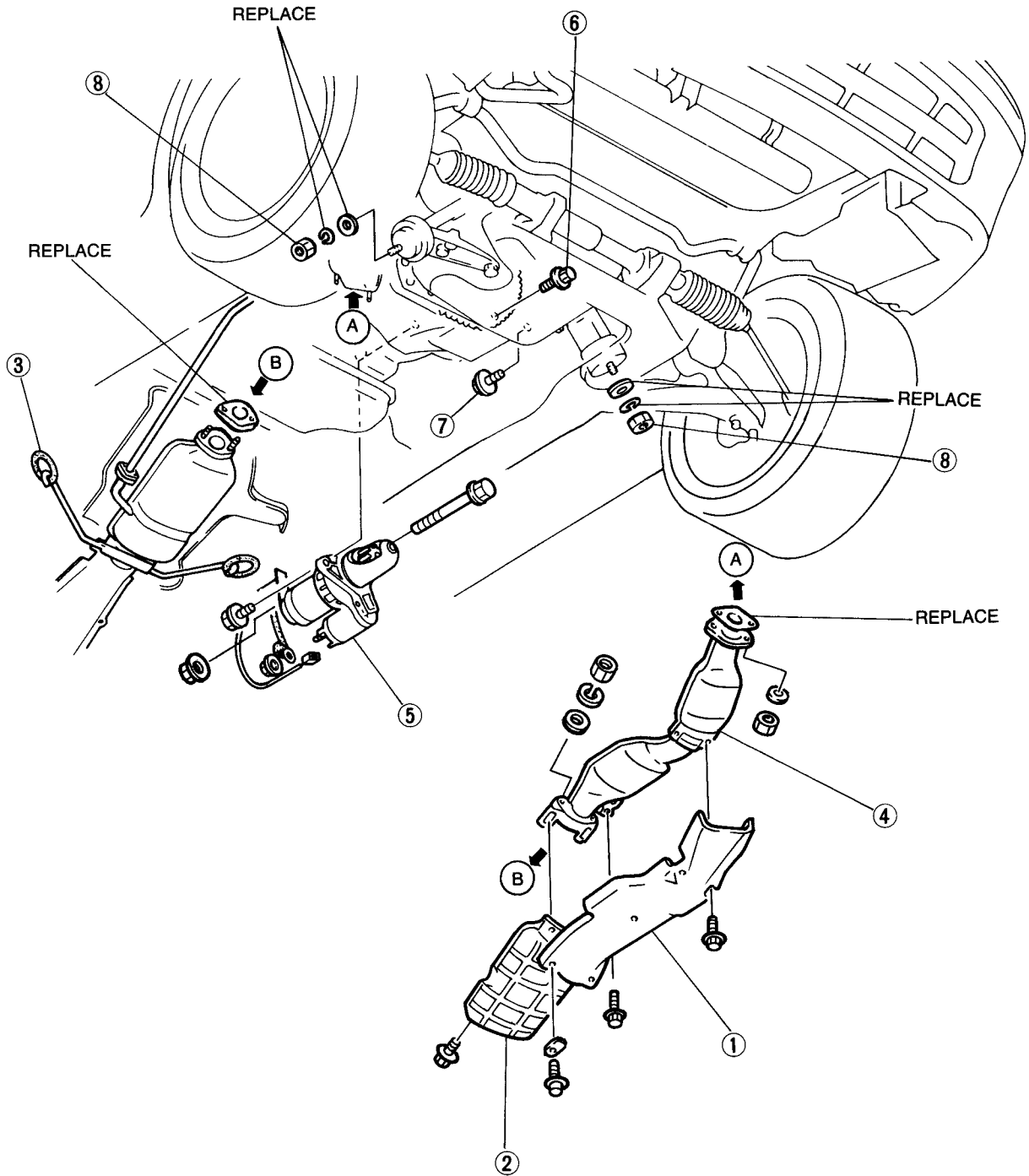

97U0CX-042

- | | |
|----------------------------------|---|
| 1. Exhaust pipe under cover | 5. Starter |
| 2. Catalytic converter insulator | 6. Torque converter attaching bolts (A/T) |
| 3. Exhaust pipe hangers | 7. Transmission bolts |
| 4. Exhaust pipe | 8. Engine mount nuts |

C REMOVAL (NON-TURBO)

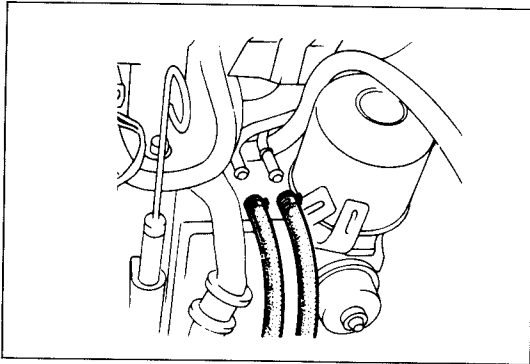

76G01A-118

Removal Note Fuel hose

Warning

- a) Cover the hose with a rag because fuel will spray out when disconnecting.
- b) Keep sparks and open flame away from the fuel area.

Plug the disconnected hoses to avoid fuel leakage.

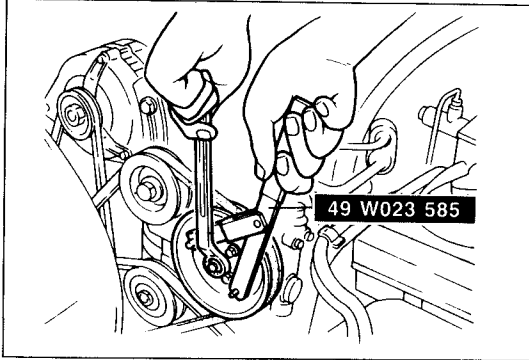

9MU0B2-250

P/S oil pump pulley

Remove the P/S oil pump pulley with the **SST**.

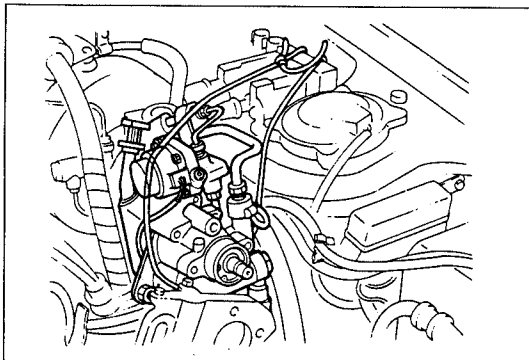







9MU0B2-251

P/S oil pump, A/C oil compressor

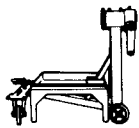
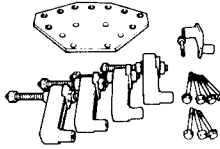
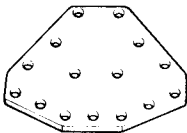
Remove the P/S pump and A/C compressor with the hoses still connected to them; secure the pump and compressor as shown in the figure.

ENGINE STAND INSTALLATION

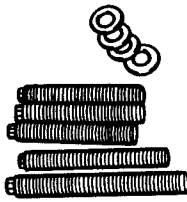
PREPARATION SST

<p>49 0107 680A</p> <p>Engine stand</p> 	<p>49 L010 1A0</p> <p>Hanger, engine stand</p> 	<p>49 L010 101</p> <p>Plate (Part of 49 L010 1A0)</p> 
<p>49 L010 102</p> <p>Arms (Part of 49 L010 1A0)</p> 	<p>49 L010 103</p> <p>Hooks (Part of 49 L010 1A0)</p> 	<p>49 L010 104</p> <p>Nuts (Part of 49 L010 1A0)</p> 
<p>49 L010 105</p> <p>Bolts (Part of 49 L010 1A0)</p> 	<p>49 L010 106</p> <p>Bolts (Part of 49 L010 1A0)</p> 	<p style="text-align: right;">9MU0B2-073</p>

INSTALLATION Engine Hanger

1. Remove the left engine mount, A/C compressor and P/S oil pump bracket.
2. Remove two studs on the front housing.

97U0CX-043

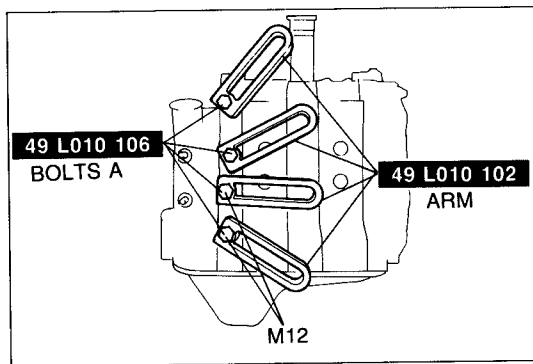

97U0CX-044

3. Install the **SST (arms)** to the block holes as shown in the figure and loosely tighten bolts A.

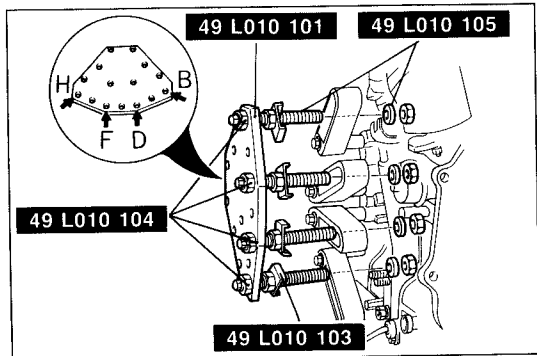

97U0CX-045

4. Assemble the **SST (bolts, nuts, hooks and plate)**.
5. Install the **SST** assembly to the respective arms while adjusting parallelism between the arms and plate by turning the bolts and nuts.

C ENGINE STAND INSTALLATION

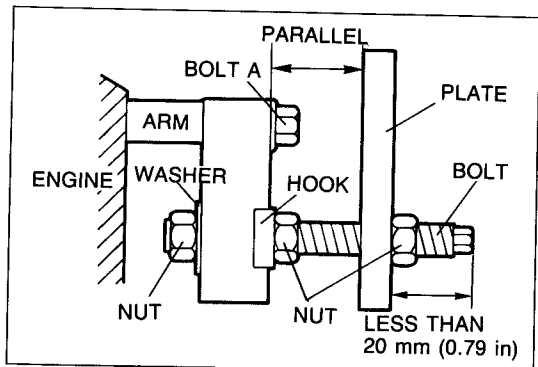

97U0CX-046

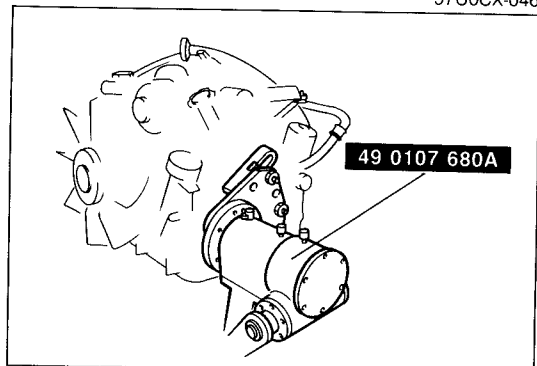

97U0CX-047



Warning
Use special caution while turning the engine stand handle to prevent hand injury.

6. Tighten the bolts and nuts to fix the **SST**.

7. Install the engine on the **SST**.

DISASSEMBLY

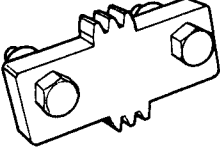
PREPARATION
SST

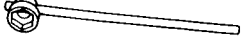
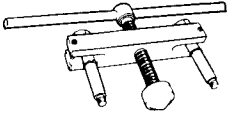
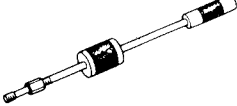
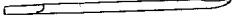
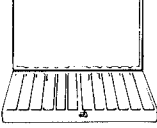
<p>49 F011 101 Ring gear brake</p> 	<p>49 1881 055 Counter weight stopper</p> 	<p>49 0820 035 Flywheel box wrench</p> 
<p>49 0839 305A Counter weight puller</p> 	<p>49 0813 215A Tubular dowel puller</p> 	<p>49 0813 225 Oil seal remover</p> 
<p>49 0813 250 Seal case</p> 	97U0CX-048	

1. Code all identical parts (such as rotors, rotor oil seals, rotor seals, and seal springs) so that they can be reinstalled in the location from which they were removed.
2. Clean the parts with steam; blow off any remaining water with compressed air.

Note

During the disassembly of any part or system, be sure to study its order of assembly. Also, note any deformation, wear, or damage.

97U0CX-049

C DISASSEMBLY (TURBO)

AUXILIARY PARTS (TURBO)

1. Remove in the sequence shown in the figure referring to the **Disassembly Note**.
2. Inspect all parts and repair or replace as necessary.

97U0CX-050

STEP 1

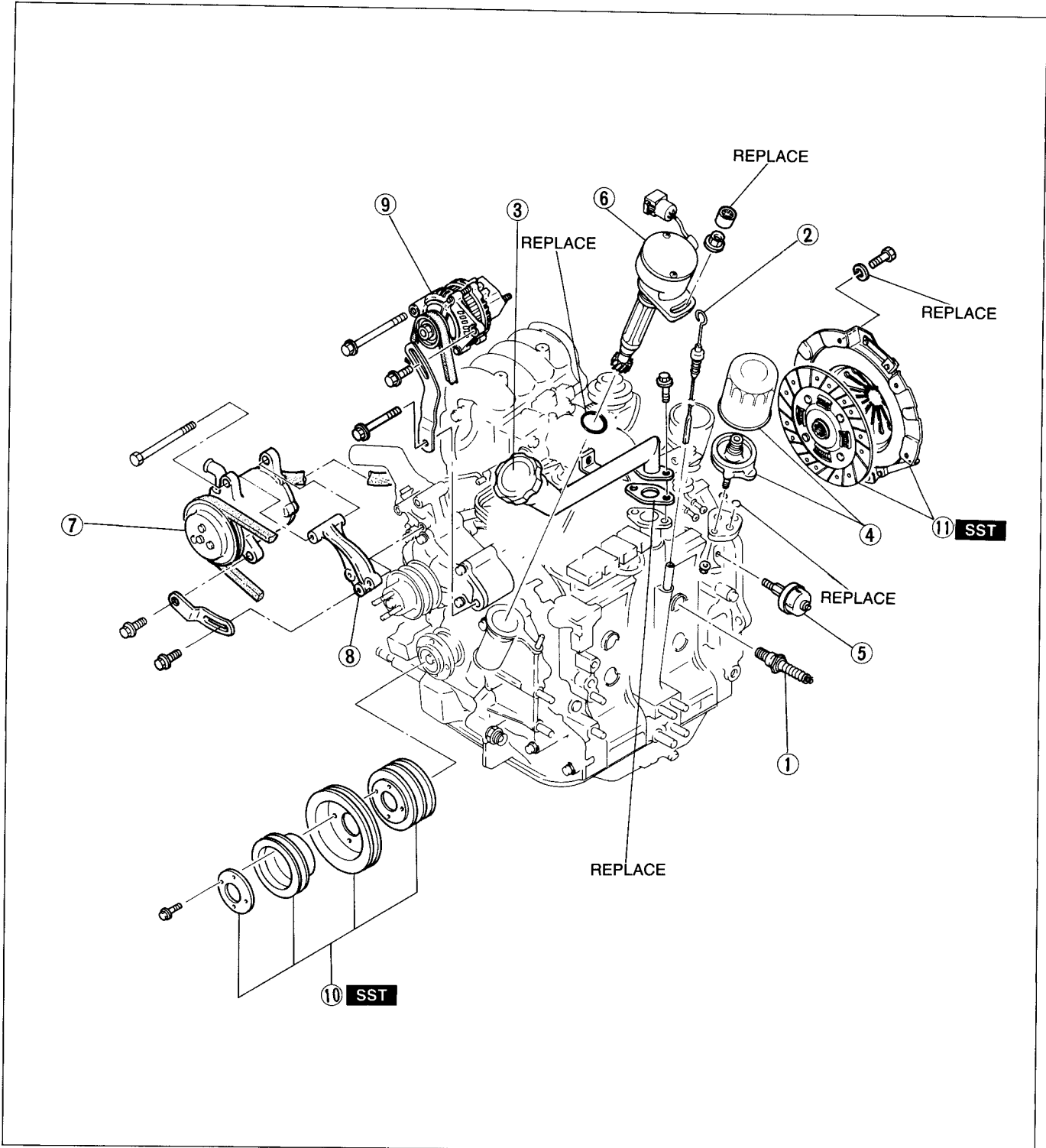

97U0CX-051

- | | |
|-------------------------------|----------------------------------|
| 1. Spark plugs | 7. Air pump and drive belt |
| 2. Oil level gauge | 8. Air pump bracket |
| 3. Oil filler pipe | 9. Alternator and drive belt |
| 4. Oil filter and filter body | 10. Eccentric shaft pulleys |
| 5. Oil pressure gauge | 11. Clutch cover and clutch disc |
| 6. Crank angle sensor | |

Service Section H

C DISASSEMBLY (TURBO)

1. Second vacuum piping
2. Throttle and dynamic chamber
3. Primary fuel injectors and distribution pipe
4. Air control valve
5. Water pipe
6. Turbocharger and insulator
7. Air hoses
8. Housing oil nozzles and manifold oil nozzles
9. Intake manifold

10. Exhaust manifold and insulator
11. Metering oil pump
Service Section D
12. Water pump
Service Section E
13. Dynamic chamber bracket
14. Engine harness and vacuum piping
15. Oil inlet pipe

97U0CX-053

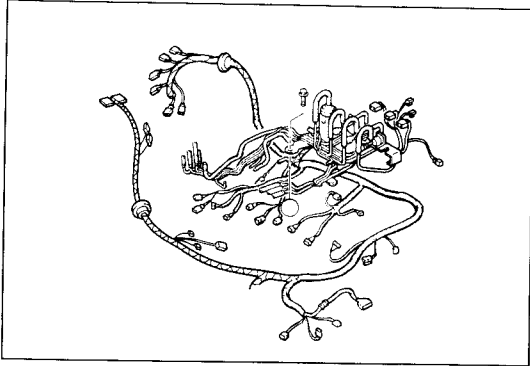

97U0CX-054

Disassembly Note

Engine harness and vacuum piping

Remove the engine harness and vacuum piping as an assembly.

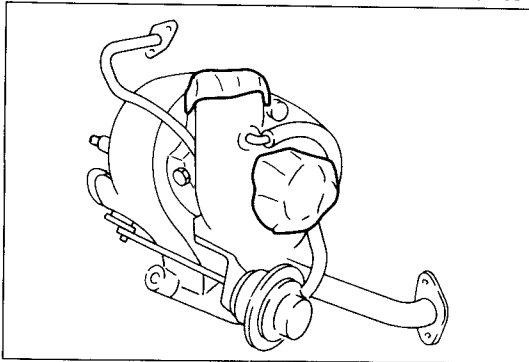

77U01X-017

Turbocharger

Cover the intake and exhaust ports and oil passages to prevent dirt or other contaminants from entering.

AUXILIARY PARTS (NON-TURBO)

1. Remove in the sequence shown in the figure referring to the **Disassembly Note**.
2. Inspect all parts and repair or replace as necessary.

97U0CX-055

STEP 1

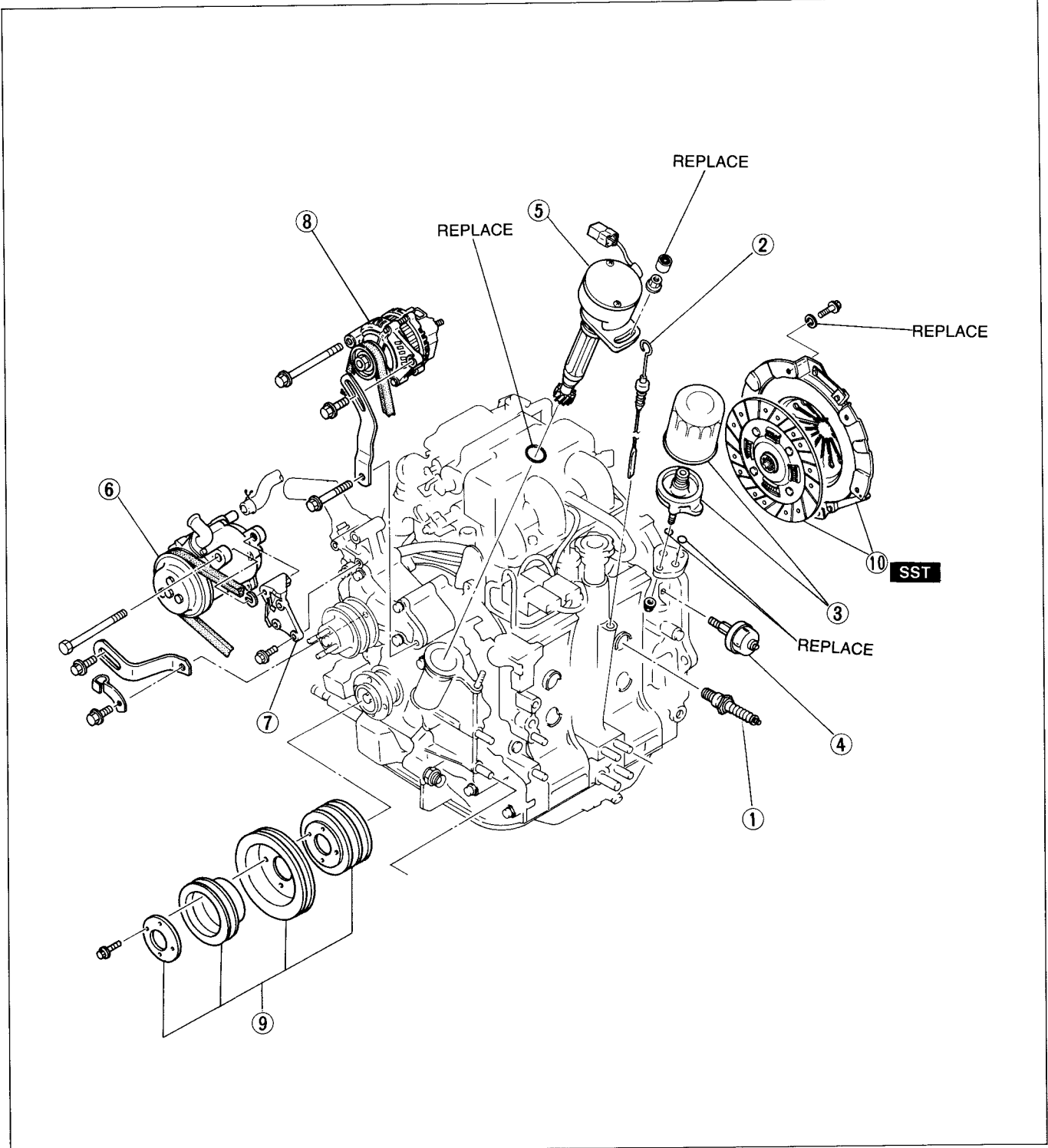

97U0CX-056

1. Spark plugs
2. Oil level gauge
3. Oil filter and filter body
4. Oil pressure gauge
5. Crank angle sensor
6. Air pump and drive belt

7. Air pump bracket
8. Alternator and drive belt
9. Eccentric shaft pulleys
10. Clutch cover and clutch disc

Service Section H

C DISASSEMBLY (NON-TURBO)

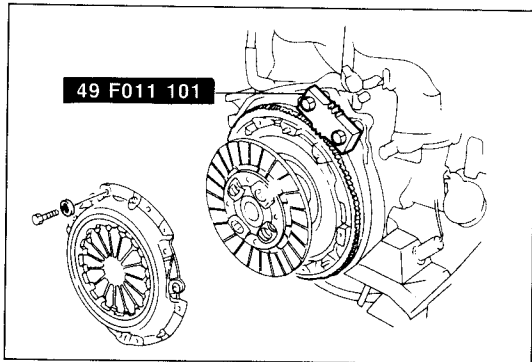

97U0CX-057

Disassembly Note

Clutch disc and clutch cover

Remove the clutch disc and clutch cover with the **SST**.

Caution

Place a rag between the **SST** and the vacuum pipes to protect the pipes.

STEP 2

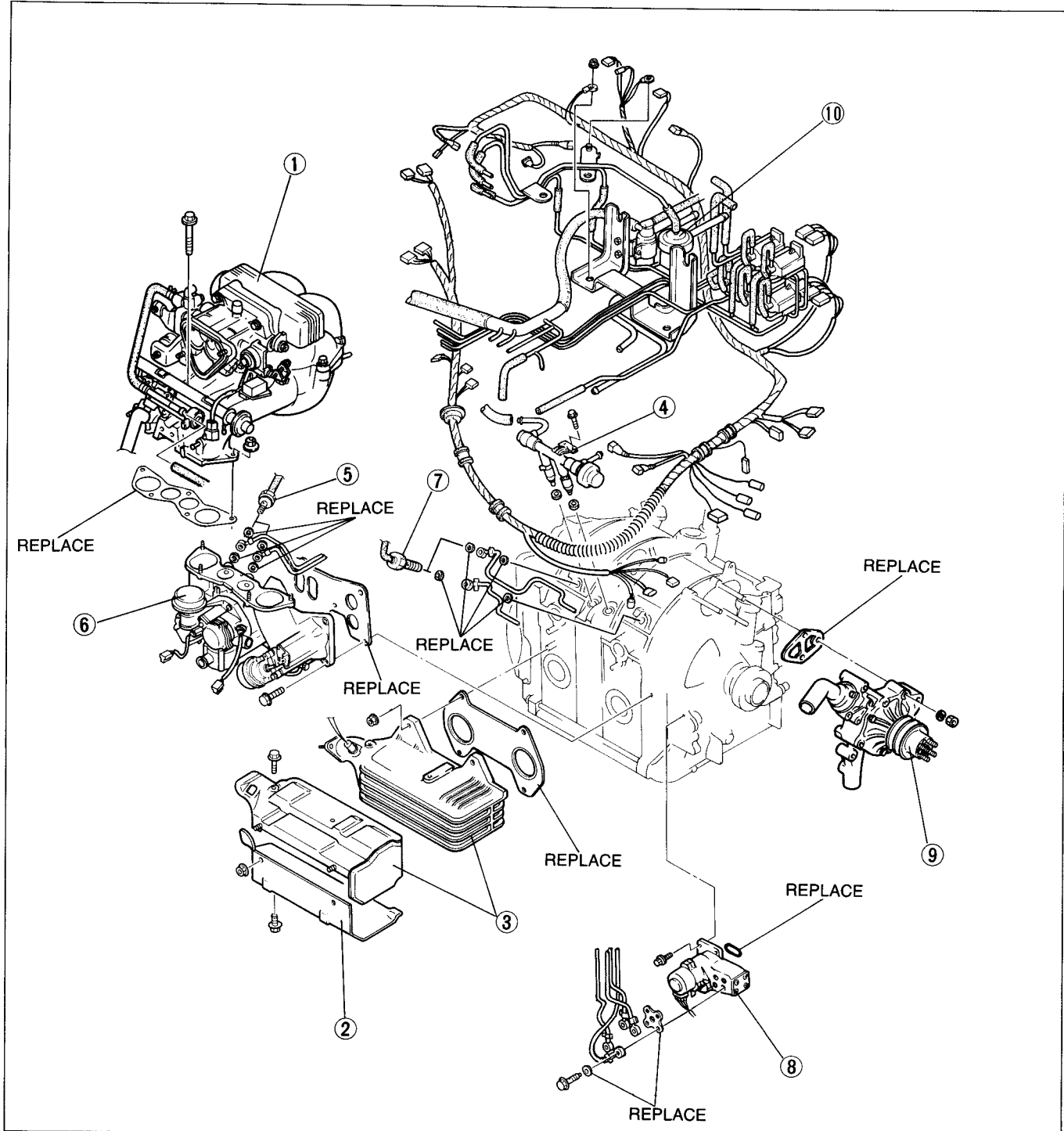

1. Throttle and dynamic chamber
2. Exhaust absorber plate
3. Exhaust manifold and insulator
4. Fuel injectors and delivery pipe
5. Manifold oil nozzles and metering oil tubes
6. Intake manifold

7. Housing oil nozzles and metering oil tube
8. Metering oil pump
Service Section D
9. Water pump
Service Section E
10. Engine harness and vacuum piping

97U0CX-058

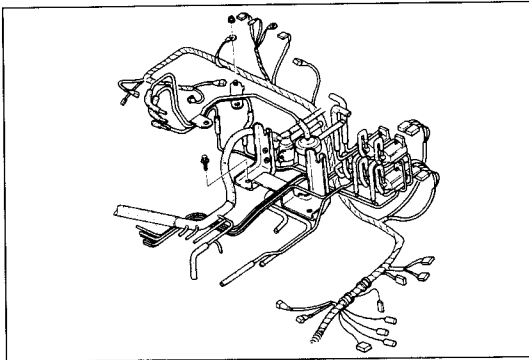

97U0CX-059

Disassembly Note

Engine harness and vacuum piping

Remove the engine harness and vacuum piping as an assembly.

MAIN PARTS

1. Remove the main parts in the manner described from page C-30.
2. Inspect all parts and repair or replace as necessary.

Component 1 — Housing Related Parts

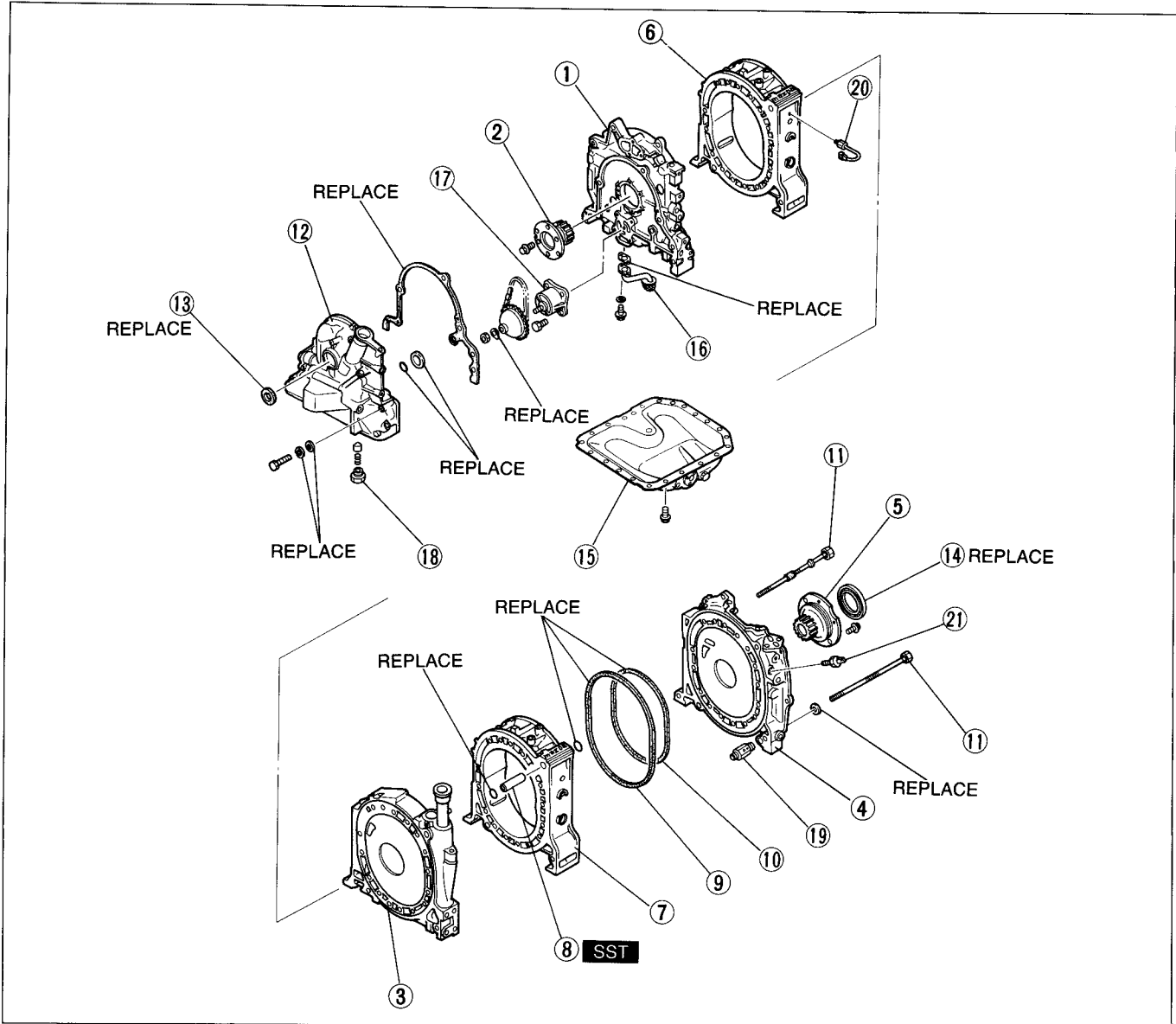

97U0CX-060

- | | | | |
|--------------------------|-----------|----------------------------------|-----------|
| 1. Front housing | | 10. Inner sealing rubber | |
| Inspection..... | page C-39 | 11. Tension bolt | |
| 2. Front stationary gear | | 12. Front cover | |
| Inspection..... | page C-40 | 13. Front oil seal | |
| 3. Intermediate housing | | 14. Rear oil seal | |
| Inspection..... | page C-39 | 15. Oil pan | |
| 4. Rear housing | | Service | Section D |
| Inspection..... | page C-39 | 16. Oil strainer | |
| 5. Rear stationary gear | | 17. Oil pump | |
| Inspection..... | page C-40 | Service | Section D |
| 6. Front rotor housing | | 18. Oil pressure control valve | |
| Inspection..... | page C-42 | Service | Section D |
| 7. Rear rotor housing | | 19. Oil pressure regulator valve | |
| Inspection..... | page C-42 | Service | Section D |
| 8. Tubular dowel pin | | 20. Knock sensor | |
| 9. Outer sealing rubber | | 21. Heat gauge unit | |

Component 2 — Rotating Related Parts

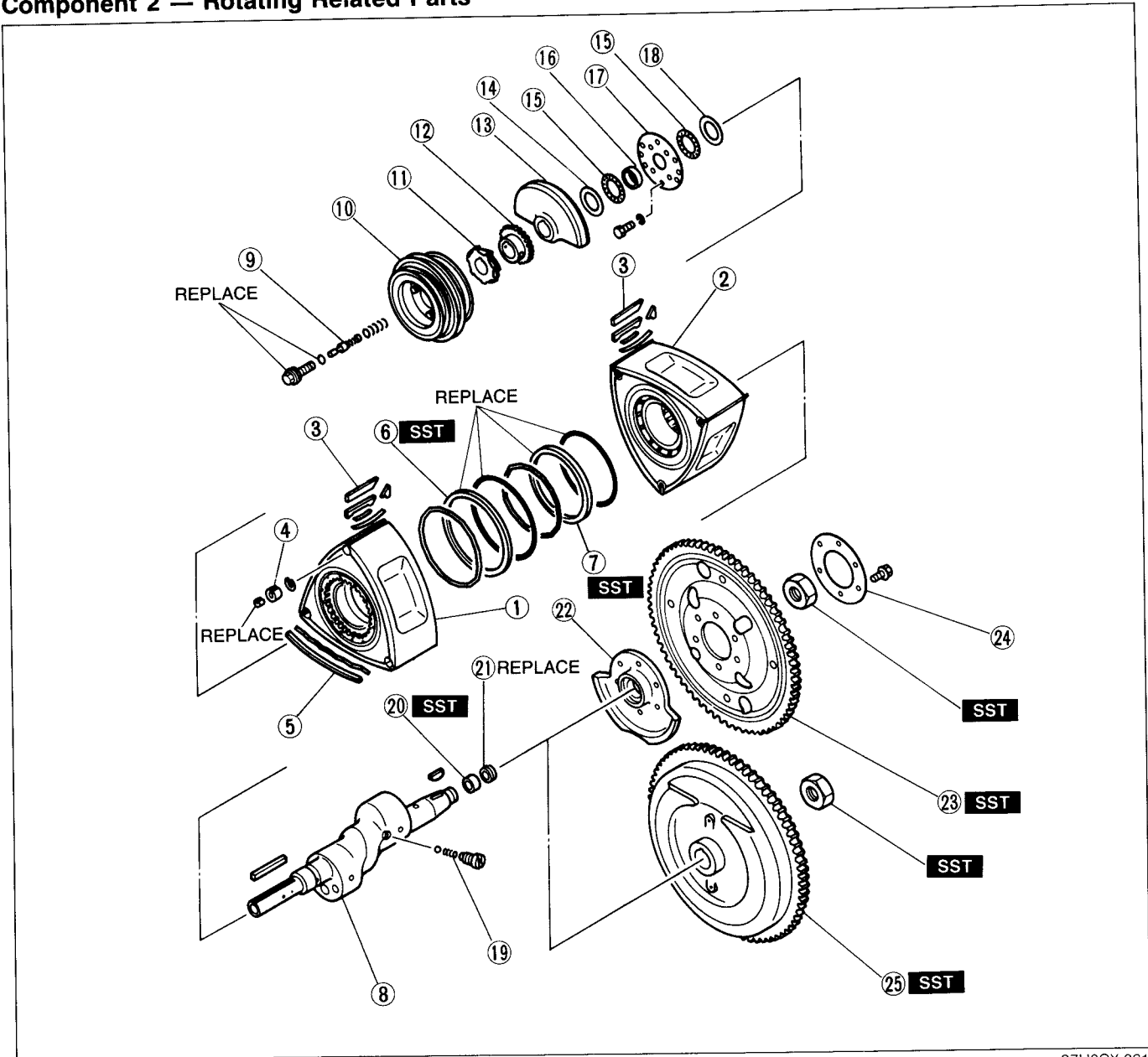

97U0CX-061

- | | | | |
|---------------------------------------|-----------|--|-----------|
| 1. Front rotor
Inspection..... | page C-42 | 11. Distributor drive gear | |
| 2. Rear rotor
Inspection..... | page C-42 | 12. Oil pump drive sprocket | |
| 3. Apex seal
Inspection..... | page C-44 | 13. Balance weight | |
| 4. Corner seal
Inspection..... | page C-45 | 14. Thrust washer | |
| 5. Side seal
Inspection..... | page C-45 | 15. Thrust needle bearing
Inspection..... | page C-46 |
| 6. Outer oil seal
Inspection..... | page C-43 | 16. Spacer | |
| 7. Inner oil seal
Inspection..... | page C-43 | 17. Plate | |
| 8. Eccentric shaft
Inspection..... | page C-46 | 18. Thrust plate
Inspection..... | page C-46 |
| 9. Oil bypass valve | | 19. Oil jet valve | |
| 10. Eccentric shaft pulley | | 20. Pilot bearing (M/T) | |
| | | 21. Oil seal (M/T) | |
| | | 22. Counter weight (A/T) | |
| | | 23. Drive plate (A/T) | |
| | | 24. Back plate (A/T) | |
| | | 25. Flywheel (M/T) | |

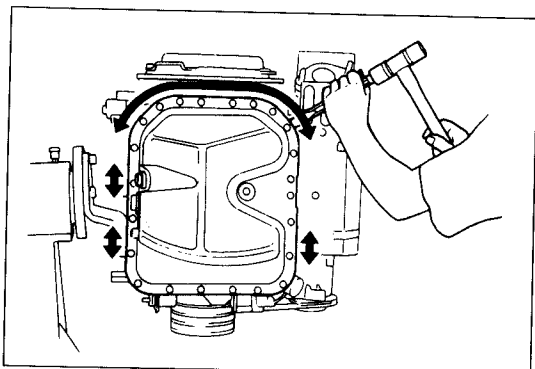

97U0CX-062

Oil Pan

1. Remove the right engine mount and oil pan attaching bolts.
2. Remove the oil pan by inserting screwdriver or a suitable tool into only the areas shown in the figure.

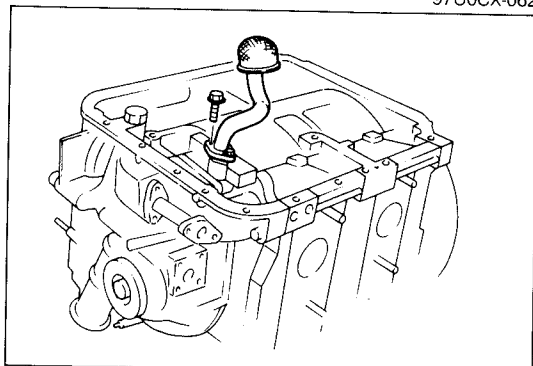

67U01X-046

Oil Strainer

Remove the oil strainer.

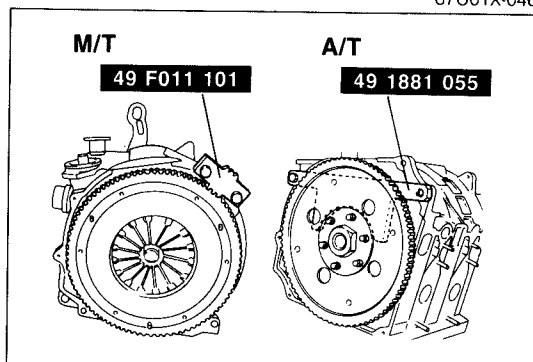

97U0CX-063

Eccentric Shaft Lock Bolt and Bypass Valve

1. Vehicle with **M/T**
Attach the **SST** to the flywheel.

Vehicle with **A/T**
Attach the **SST** to the counter weight.

2. Remove the eccentric shaft lock bolt.
3. Remove the O-ring from the lock bolt.

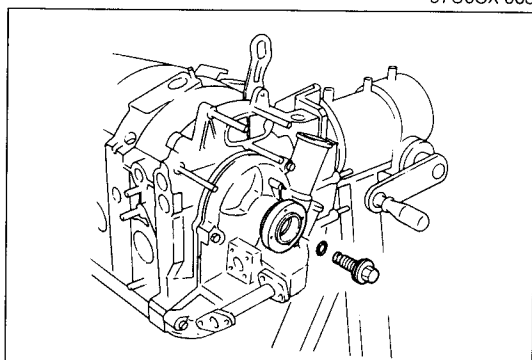

97U0CX-064

4. Remove the eccentric shaft bypass valve and spring.
5. Remove the eccentric shaft pulley boss.

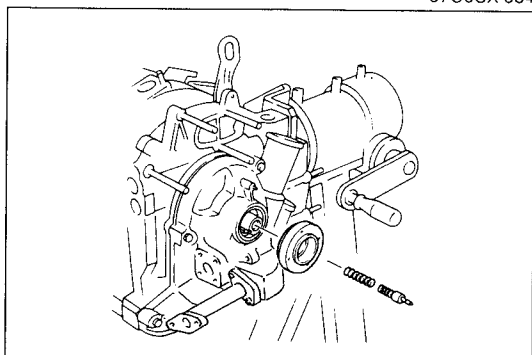

67U01X-049

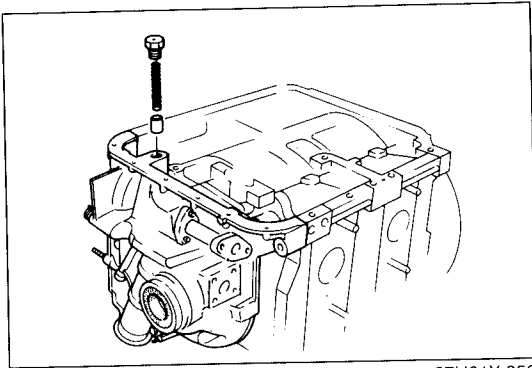

67U01X-050

Front Cover

1. Remove the oil pressure control valve.
2. Remove the front cover.

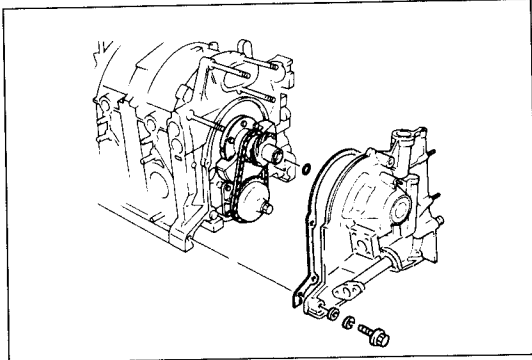

97U0CX-065

3. Remove the gasket, O-ring and backup ring.
4. Remove the distributor drive gear.

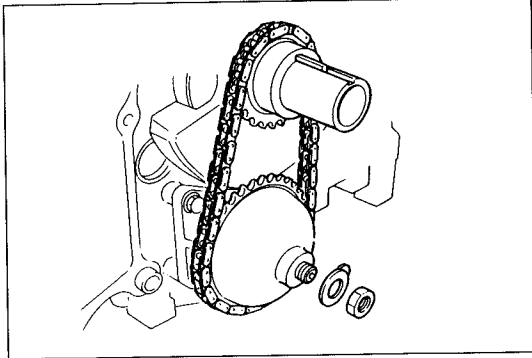

97U0CX-066

Oil Pump

1. Lift the lock washer tab and remove the sprocket locknut.
2. Remove the oil pump drive gear, driven gear, and drive chain as an assembly.

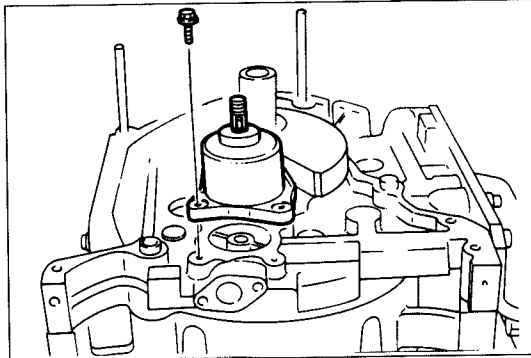

97U0CX-067

3. Remove the oil pump.

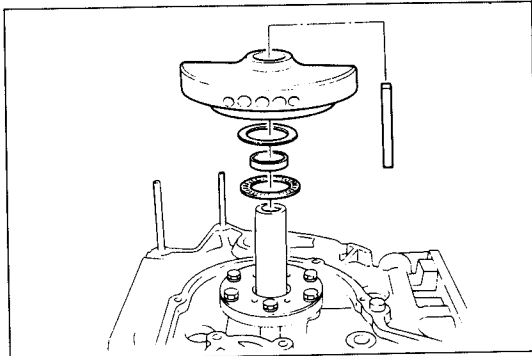

67U01X-054

Balance Weight, Bearing and Spacer

Remove the following parts from the eccentric shaft:

1. Key
2. Balance weight
3. Thrust washer
4. Thrust needle bearing
5. Spacer

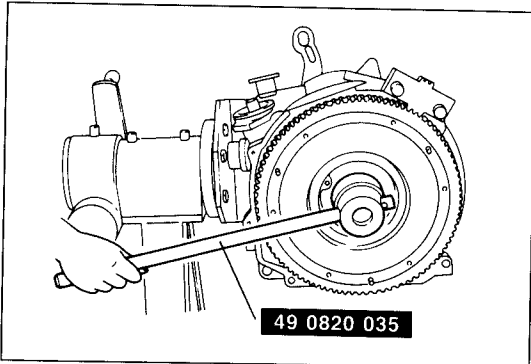

97U0CX-068

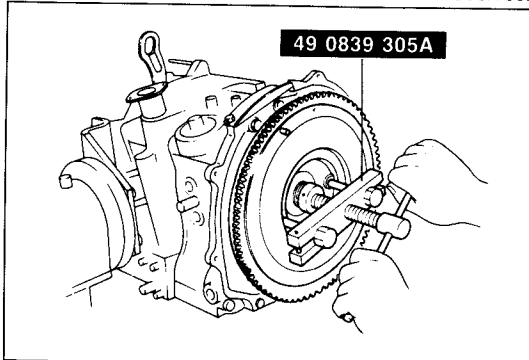

97U0CX-069

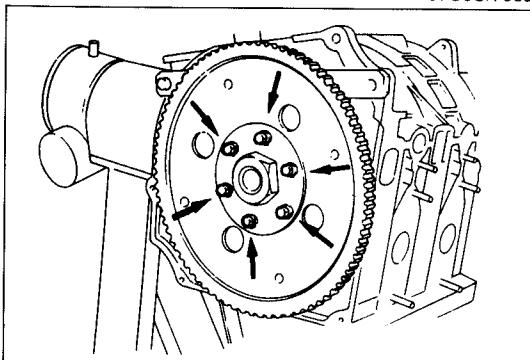

97U0CX-070

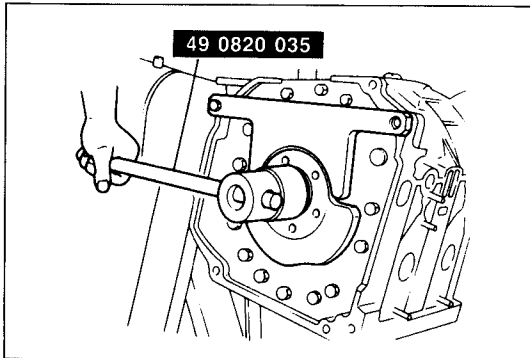

97U0CX-071

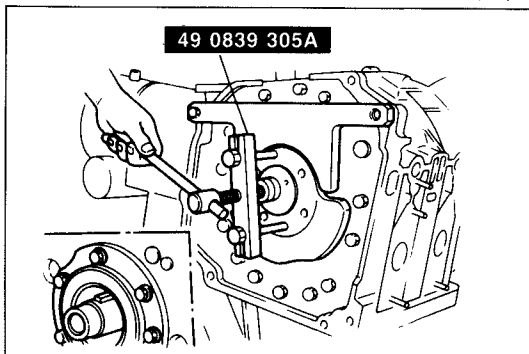

97U0CX-072

Flywheel (M/T)

1. Remove the flywheel nut with the **SST**.
2. Remove the flywheel with the **SST**.
3. Remove the key.
4. Remove the ring gear brake.

Drive Plate and Counter Weight (A/T)

1. Remove the retainer and the drive plate.
2. Remove the flywheel nut with the **SST**.
3. Remove the counterweight with the **SST**.
4. Remove the key.
5. Remove the **SST**.

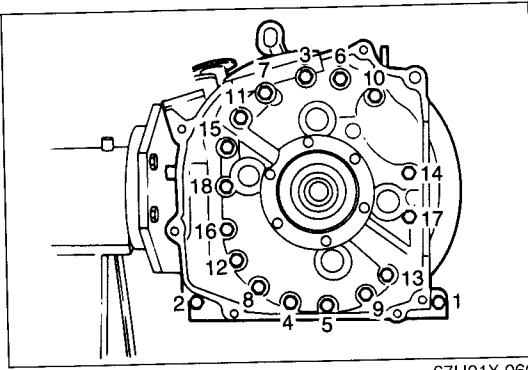

67U01X-060

Tension Bolts

Loosen the tension bolts gradually and in the sequence shown in the figure; then remove them.

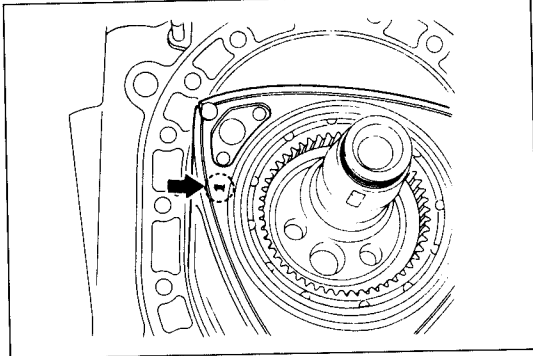

67U01X-061

Note

Rotor seals — Apex seals, side seals and corner seals — are distinguishable by the numbers near each respective groove on the rotor face. Place them in the seal case (49 0813 250) in accordance with the numbers.

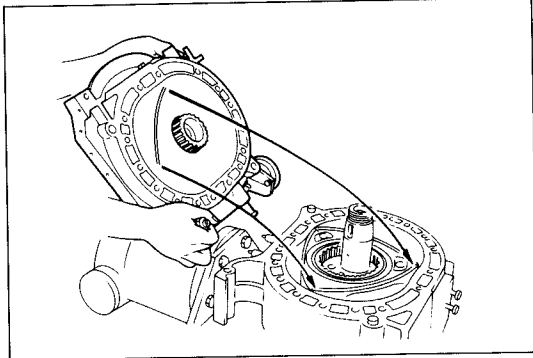

67U01X-062

Rear Housing

1. Remove the rear housing.
If the seals stick to the housing when it is removed, put them back into their original position.

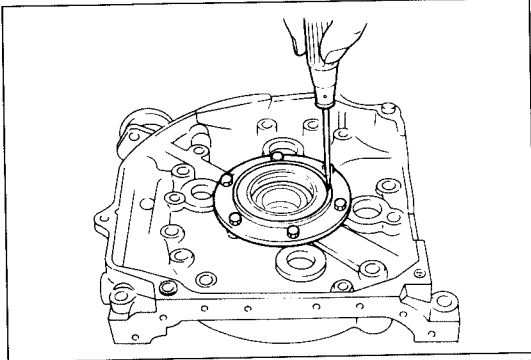

67U01X-063

2. Remove the sealing rubbers and the oil seal from the rear housing.

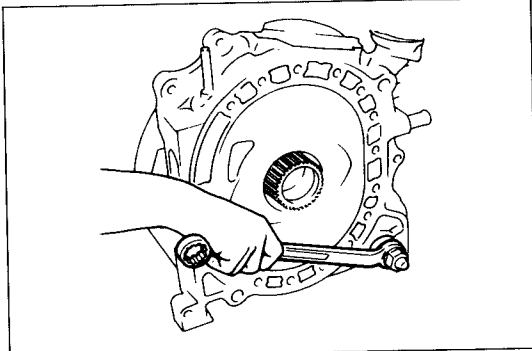

67U01X-064

3. Remove the pressure regulator.

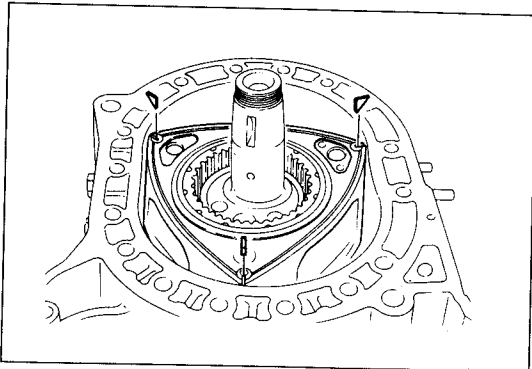

67U01X-065

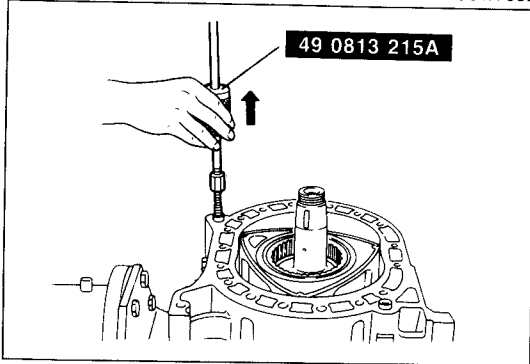

97U0CX-073

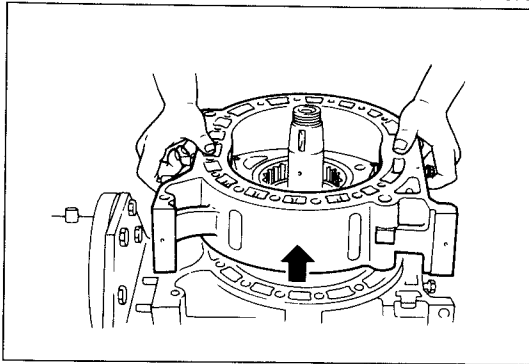

67U01X-067

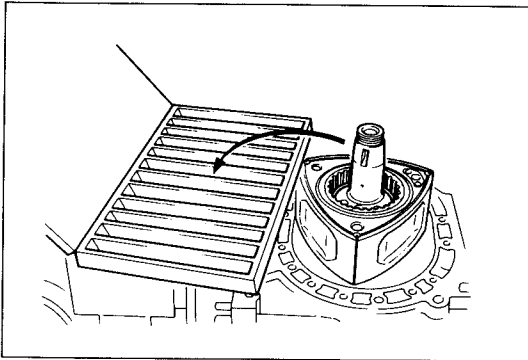

67U01X-068

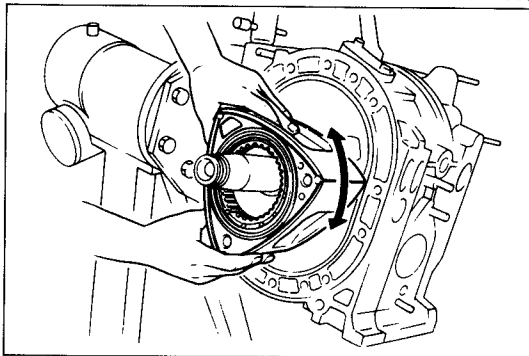

67U01X-069

Rear Rotor Housing

1. Remove the side pieces and place them in the **seal case** (49 0813 250).
2. Remove the tubular dowels using the **SST**.
3. Remove the rotor housing. Be careful not to drop the apex seals.
4. Remove the O-ring from the upper dowel hole.

Rear Rotor

1. Remove the seals and springs, and place them in position in **seal case** (49 0813 250).
2. Remove the rotor.
If the seals stick on the intermediate housing surface, put them back into their respective position in the rotor.

Caution

Do not place the rotor on a hard surface.

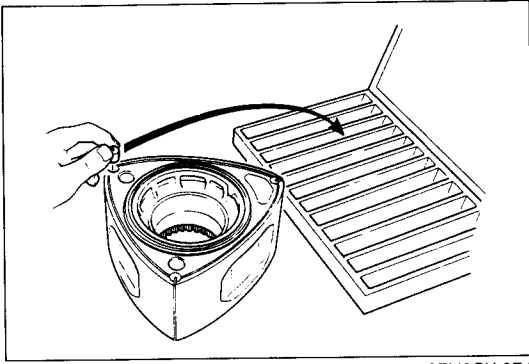

97U0CX-074

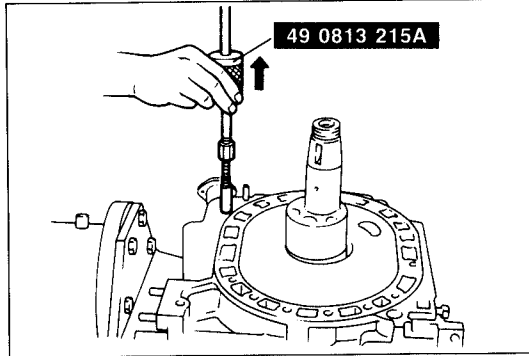

97U0CX-075

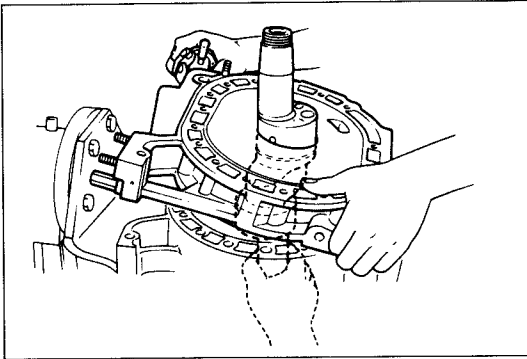

67U01X-072

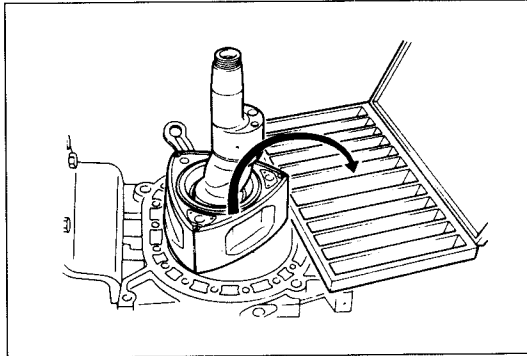

67U01X-073

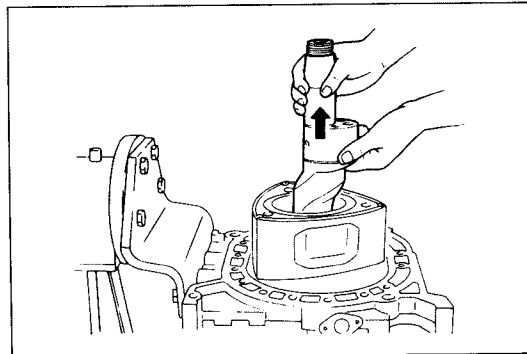

97U0CX-076

3. Remove the seals and springs, and put them in position in the **seal case** (49 0813 250).
4. Mark the rotor with an "R" for proper reassembly.

Intermediate Housing

1. Remove the tubular dowels using the **SST**.

2. Turn the eccentric shaft so that the rotor journal faces in the short axial direction.
3. Remove the intermediate housing while pushing the eccentric shaft up.
4. If the seals stick to the intermediate housing surface, put them back into their respective position in the rotor.
5. Remove the sealing rubbers.

Front Rotor Housing

1. Remove the side pieces and place them in **seal case** (49 0813 250).
2. Remove the rotor housing. Be careful not to drop the apex seals.
3. Remove the O-ring from the upper dowel hole.

Eccentric Shaft

1. Remove the eccentric shaft.

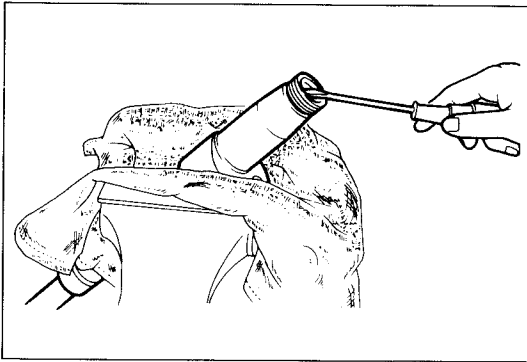

97U0CX-077

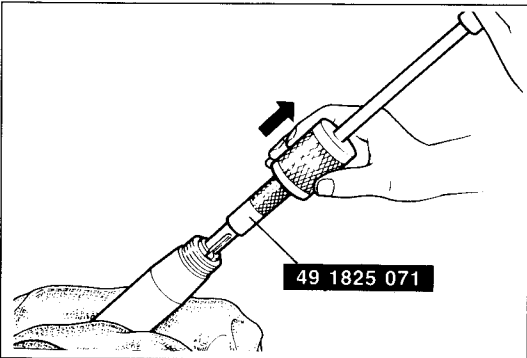

97U0CX-078

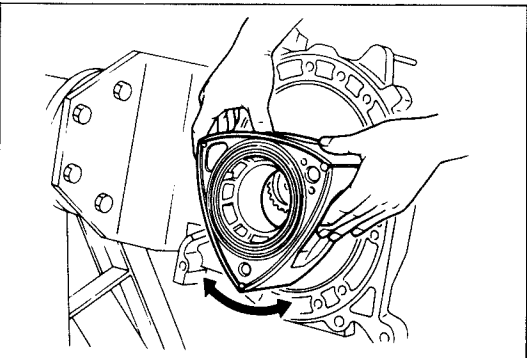

67U01X-075

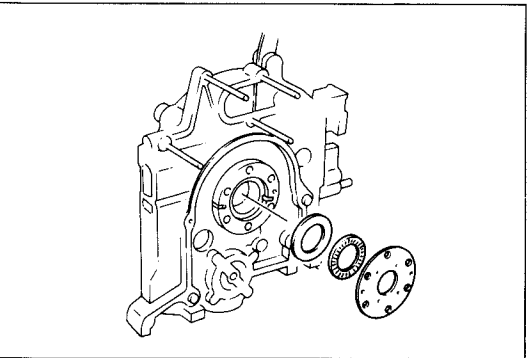

97U0CX-079

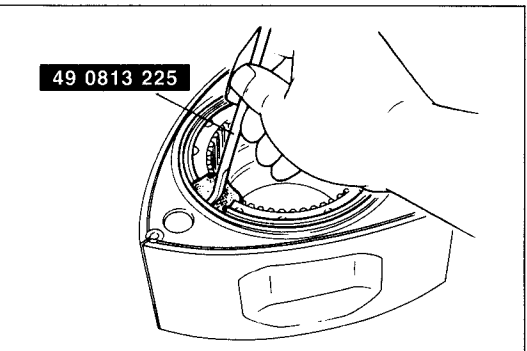

97U0CX-080

2. Support the eccentric shaft in a vise and remove the oil seal with a screwdriver.

Caution

Use protective cloth and plate on the vise jaws.

3. Remove the needle bearing from the eccentric shaft with the **SST**.

Front Rotor

Remove the front rotor in the same procedure as the removal of the rear rotor.

Front Housing

1. Remove the thrust plate and needle bearing from stationary gear.
2. Remove the sealing rubber from the front housing.
3. Remove the front housing from the **engine hanger** (49 L010 1A0).

Rotor Oil Seal

1. Remove the outer oil seal from the rotor using the **SST**.
2. Remove the inner oil seal in the same manner.
3. Remove the oil seal springs.
4. Remove the O-ring from the oil seal.

CLEANING

PREPARATION SST

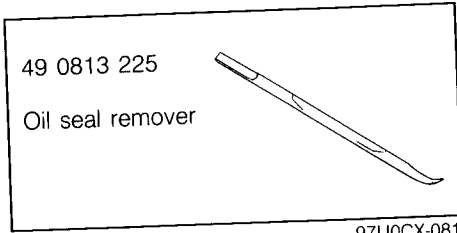

97U0CX-081

Clean all of the parts taking care to remove any gasket fragments, dirt, oil or grease, carbon, or other materials. 97U0CX-082

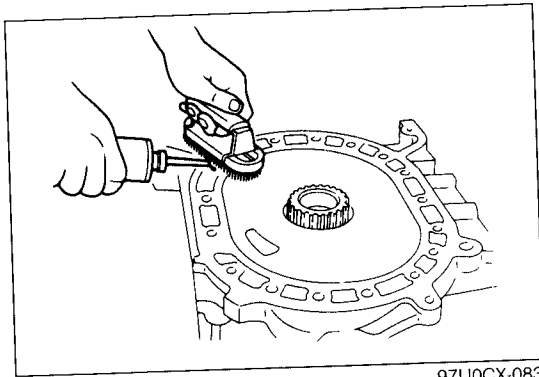

97U0CX-083

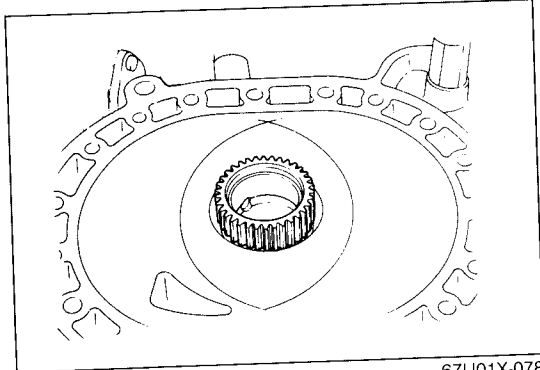

67U01X-078

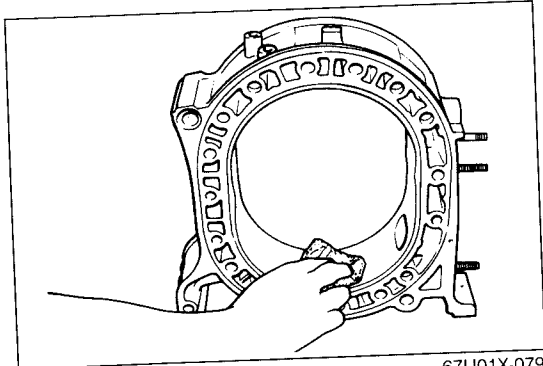

67U01X-079

Side Housings (Front, intermediate and rear housings)

1. Remove the sealing agent from the housing surface with a cloth or a brush soaked in solvent or thinner.
2. Remove all carbon on the rotor chamber surface with extra-fine emery paper. If using a carbon scraper, be careful not to damage the surface.

Rotor Housing

Note

Before cleaning, check for traces of gas or water leakage along the inner margin of the rotor housings.

1. Remove all carbon from the inner surface of the rotor housing by wiping with a cloth soaked in solvent or thinner.

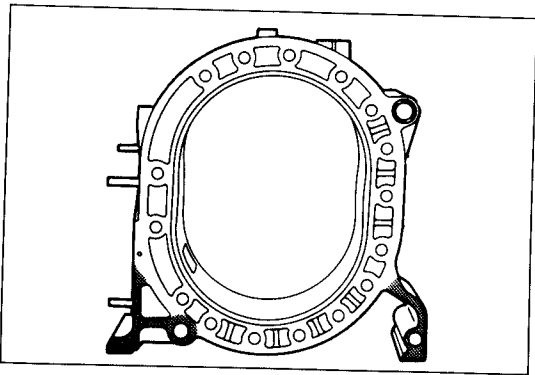

67U01X-080

2. Remove all deposits and rust from the cooling water passages on the housing.
3. Remove the sealing agent from the housing with a cloth or brush soaked in solvent or thinner.

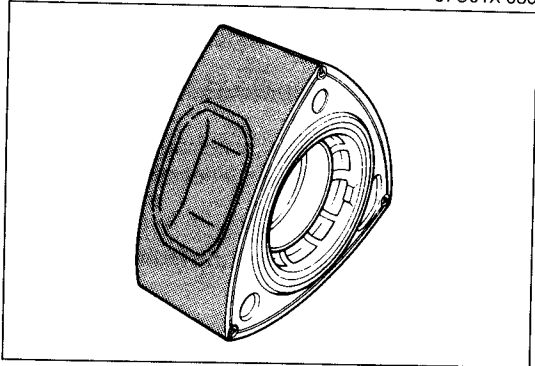

67U01X-081

Rotor

1. Remove the carbon from the rotor with a carbon remover or emery paper.

Caution

- a) Do not use emery paper on the groove of the apex seal or the side seal.
- b) Take care not to damage the soft material coating on the side surfaces.

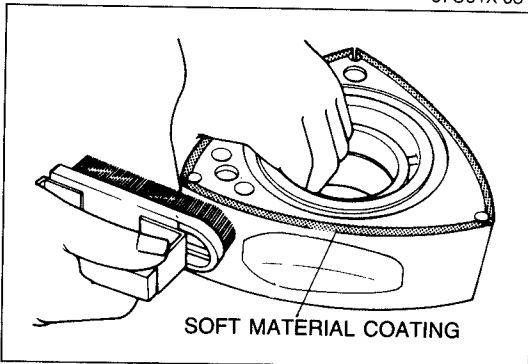

67U01X-082

2. Remove the carbon in each groove.
3. Wash the rotor with a cleaning solution.

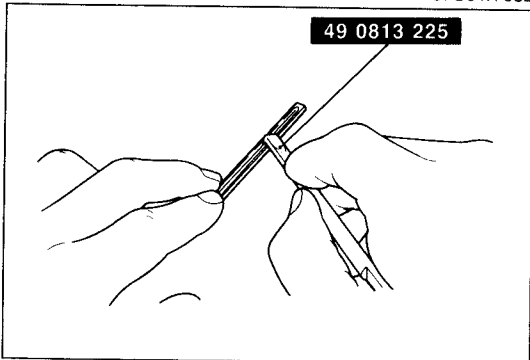

97U0CX-084

Rotor Seals (Apex, side and corner seals)

1. Remove the carbon from each seal with the SST.
2. Wash the seals with a cleaning solution.

Caution

Do not use emery paper.

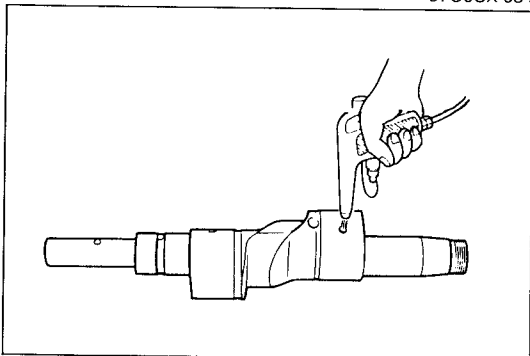



67U01X-084

Eccentric Shaft

1. Wash the eccentric shaft with a cleaning solution.
2. Blow the oil passage clean with compressed air.

INSPECTION AND REPAIR

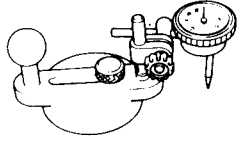
PREPARATION SST

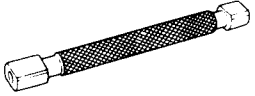
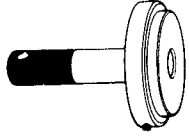
<p>49 0727 570</p> <p>Gauge body</p> 	<p>49 0813 235</p> <p>Main bearing puller and installer</p> 	<p>49 0839 165</p> <p>Corner seal gauge</p> 
97U0CX-085		
<p>49 0813 240</p> <p>Rotor bearing puller and installer</p> 		

1. Clean all parts, being sure to remove any gasket fragments, dirt, oil or grease, carbon, moisture residue, or other foreign materials. (Refer to page C-37.)
2. Inspection and repairs must be performed in the order specified.

Caution

Do not damage the joints or friction surfaces of aluminum alloy components.

97U0CX-086

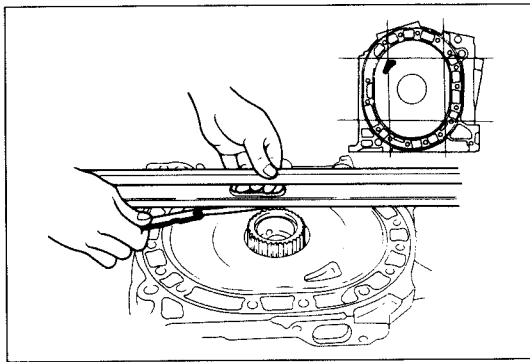

97U0CX-087

Side Housings (Front, intermediate and rear housings)

1. Check the housing surface for warpage in the four directions shown in the figure. If necessary, replace the housing.

Warpage: 0.04mm (0.0016 in) max.

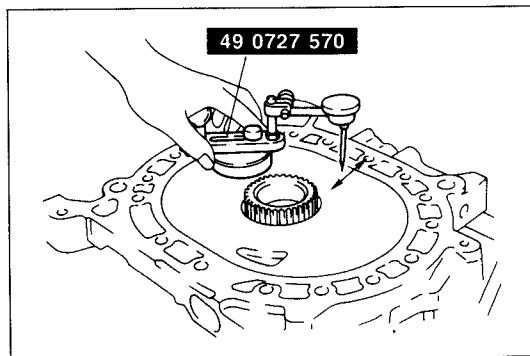

97U0CX-088

2. Check the contact surface for wear with a dial indicator mounted on the **SST**. Slide the gauge across the area as indicated in the figure.

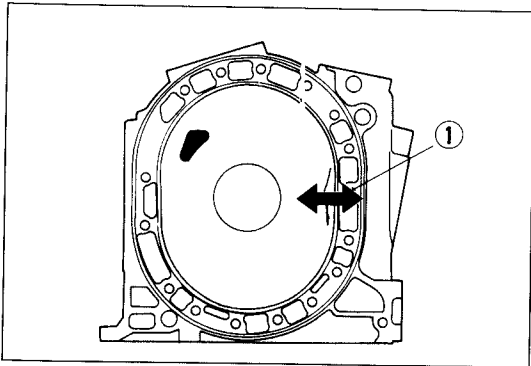

67U01X-087

(1) Side seal wear

Wear: 0.10mm (0.0039 in) max.

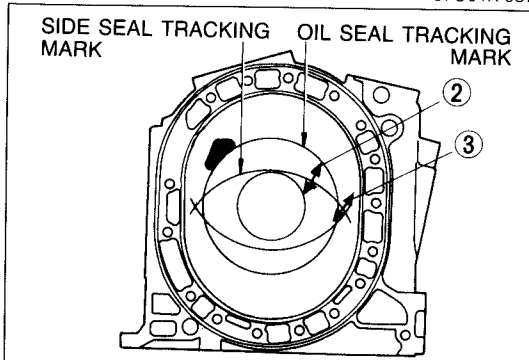

67U01X-088

(2) Side seal wear, overlapping oil seal wear

Wear: 0.01mm (0.0004 in) max.

(3) Side seal wear, outside oil seal wear

Wear: 0.10mm (0.0039 in) max.

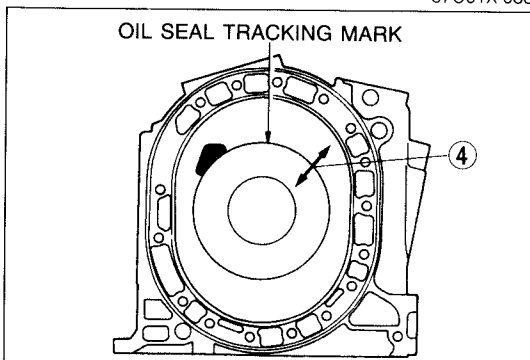

67U01X-089

(4) Oil seal wear

Wear: 0.02mm (0.0008 in) max.

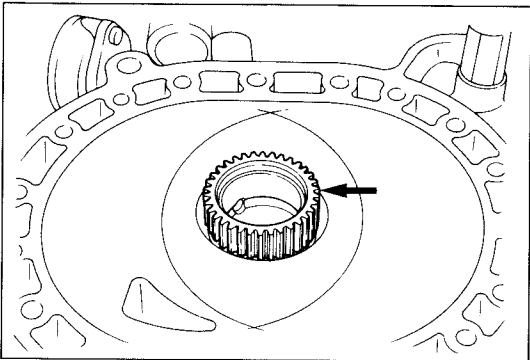

67U01X-090

Stationary Gear

1. Check the front and rear stationary gear for cracked, scored, worn, or chipped teeth.

2. If necessary, replace the stationary gear.

(1) (Front stationary gear)

Remove the plate, needle bearing, and thrust plate.

(Rear stationary gear)

Remove the attaching bolts.

(2) Remove the stationary gear using the **SST**.

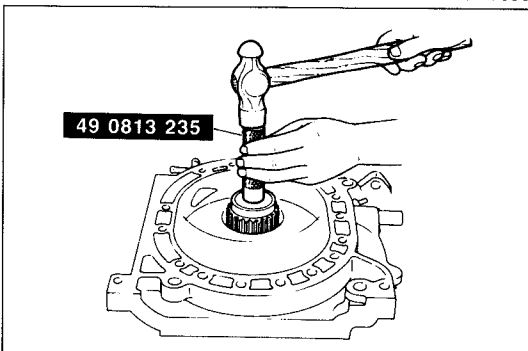

97U0CX-089

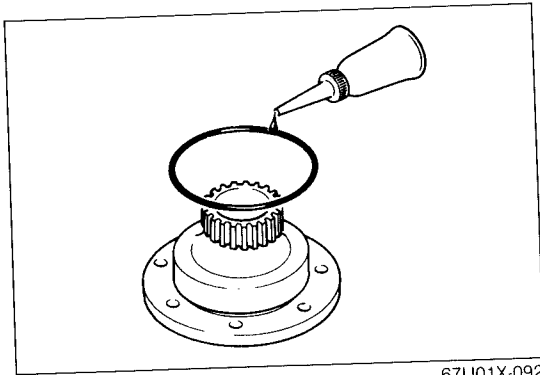

67U01X-092

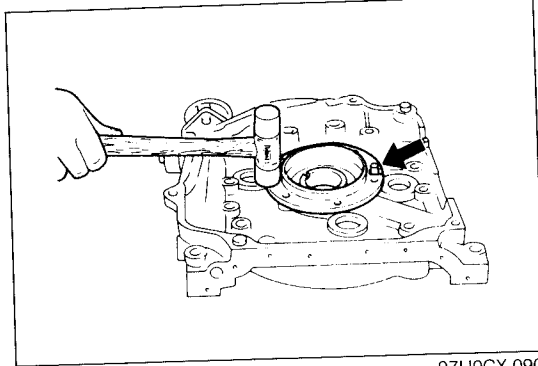

97U0CX-090

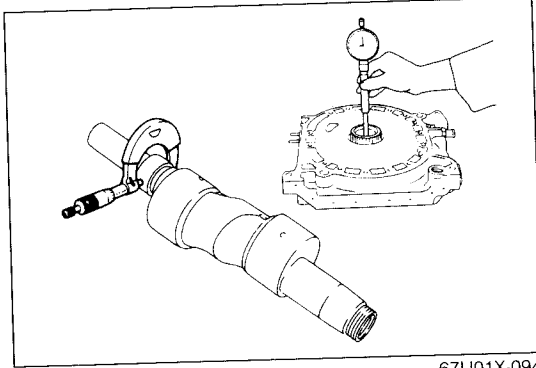

67U01X-094

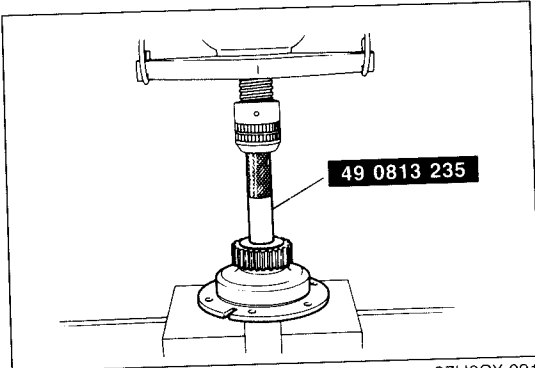

97U0CX-091

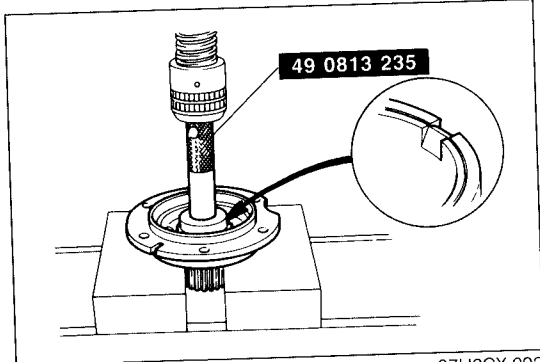

97U0CX-092

- (3) (Rear stationary gear only)
Apply petroleum jelly to a new O-ring and install it on the rear stationary gear. Apply sealant to the stationary gear flange.

- (4) Install the stationary gear to the housing so that the slot of the stationary gear is aligned with the dowel pin on the housing.

- (5) (Front stationary gear)
Install the thrust plate, needle bearing, and plate.
(Rear stationary gear)
Tighten the attaching bolts.

Tightening torque:

16—23 N·m (1.6—2.3 m·kg, 12—17 ft·lb)

Main Bearing

1. Check the main bearing for wear, scoring, flaking, or any other damage.
2. Check the main bearing clearance. Measure the inner diameter of the main bearing and the outer diameter of the eccentric shaft main journal.

Standard clearance:

0.04—0.08mm (0.0016—0.0031 in)

Clearance: 0.10mm (0.0039 in) max.

3. If necessary, replace the main bearing.
 - (1) Remove the stationary gear.
 - (2) Place the stationary gear on the support with the flange side downward.
 - (3) Press out the main bearing using the **SST** without the adaptor ring.
 - (4) Place the stationary gear on the support with the gear side downward.
 - (5) Place the new main bearing on the stationary gear so that the bearing lug is in line with the slot of the stationary gear.
 - (6) Press the main bearing in using the **SST**.

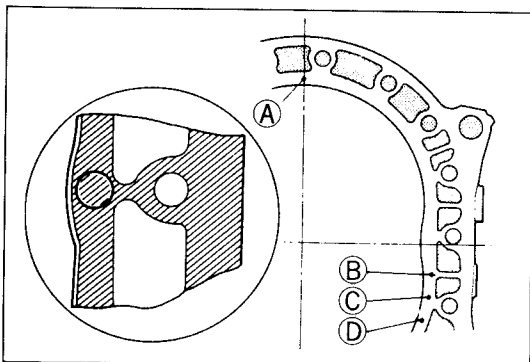

67U01X-097

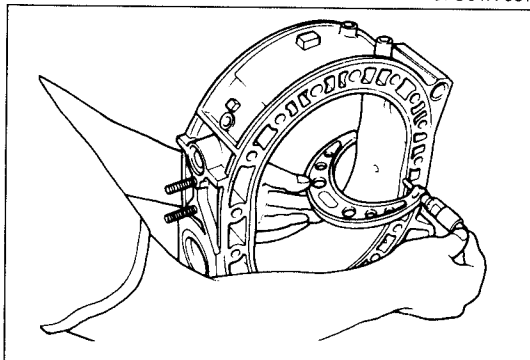

67U01X-098

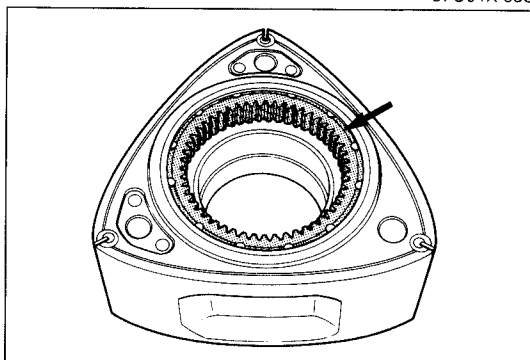

67U01X-099

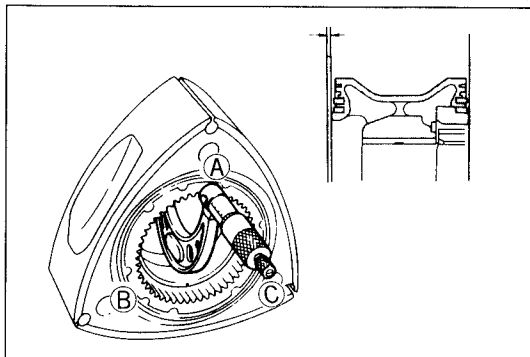

97U0CX-093

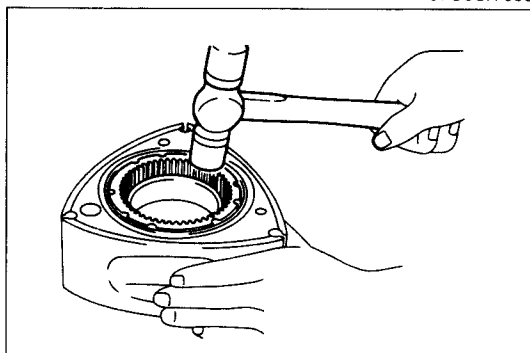

97U0CX-094

Rotor Housing

1. Check the chromium plated surface on the rotor housing for scoring, flaking, or any other damage.
2. Check the width difference of the rotor housing.
 - (1) Measure the rotor housing width at the points (A, B, C, and D) as shown in the figure.

- (2) Check the difference between the value of point A and the minimum value among the points B, C, and D.

Difference: 0.06mm (0.0024 in) max.

3. If necessary, replace the rotor housing.

Rotor

1. Carefully inspect the rotor and replace it if it is severely worn or damaged.
2. Check the internal gear for cracked, scored, worn, or chipped teeth.

3. Check the clearance between the side housing and rotor. Measure the rotor housing width (point A above) and the maximum rotor width at the three points indicated in the figure.

Standard: 0.12—0.21mm (0.0047—0.0083 in)
Clearance: 0.10mm (0.0039 in) min.

4. If the clearance is more than the specification, replace the rotor assembly.
If the clearance is less than the specification, replace the rotor assembly.

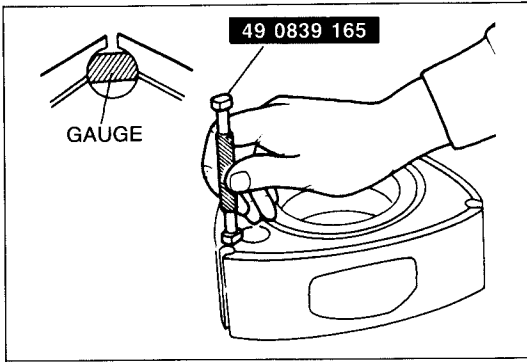

97U0CX-094

5. Check the corner seal bores for wear using the **SST**.
 - (1) If neither end of the gauge goes into the bore, use the original corner seal.
 - (2) If only one end of the gauge goes into the bore, replace the corner seal.
 - (3) If both ends of the gauge go into the bore, replace the rotor.

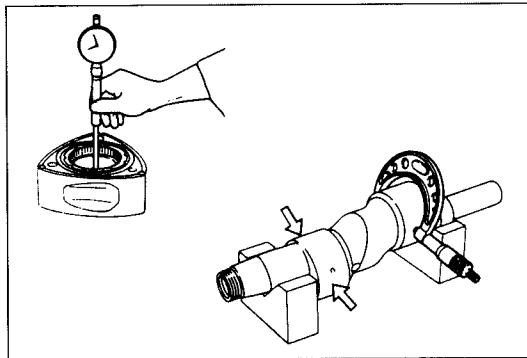

67U01X-103

Rotor Bearing

1. Check the rotor bearing for wear, flaking, scoring or any other damage.
2. Check the rotor bearing clearance. Measure the inner diameter of the rotor bearing and the outer diameter of the eccentric shaft rotor journal.

Standard clearance:

0.04—0.08mm (0.0016—0.0031 in)

Clearance: 0.10mm (0.0039 in) max.

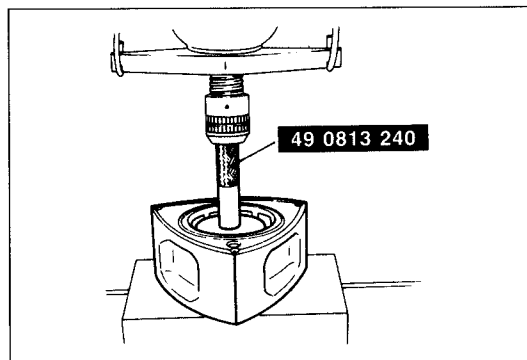

97U0CX-096

3. If necessary, replace the rotor bearing.
 - (1) Place the rotor on a support with the internal gear downward.
 - (2) Press the bearing out of the rotor using the **SST** without the adapter ring.

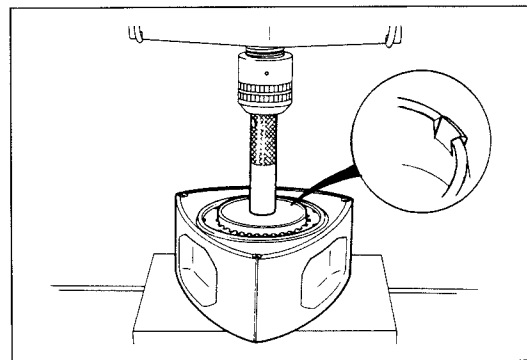

97U0CX-097

- (3) Place the rotor on the support with the internal gear facing upward.
- (4) Place the new rotor bearing on the rotor so that the bearing lug is in line with the slot of the rotor bore.
- (5) Press the bearing in until it is flush with the rotor boss, using the **SST**.

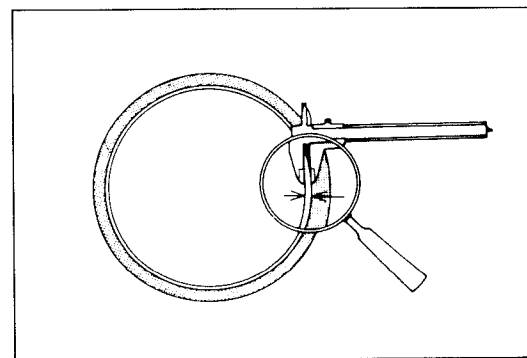

67U01X-106

Rotor Oil Seal

1. Inspect the oil seal for wear or damage. If necessary, replace it.
2. Check the oil seal lip width.

Lip width: 0.5mm (0.020 in) max.

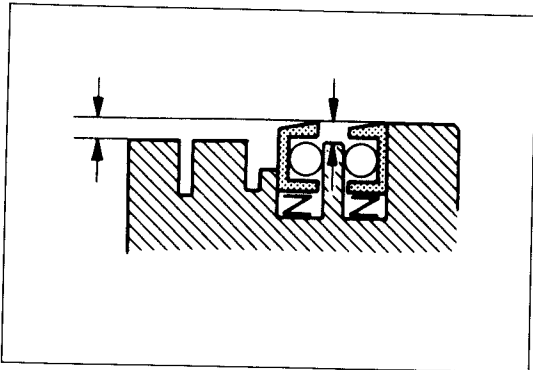

67U01X-107

3. Install the oil seal springs and oil seals into their respective grooves.
4. Check the oil seals for free vertical movement.
5. Check the oil seal protrusion.

Protrusion: 0.5mm (0.020 in) min.

If necessary, replace the oil seal or the spring.

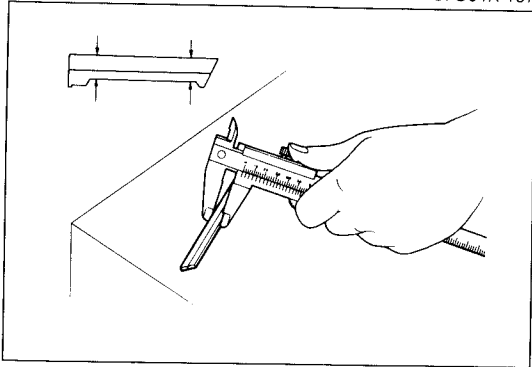

67U01X-108

Apex Seal

1. Check the apex seal for wear, cracks, and other damage. If necessary, replace it.
2. Measure the combined height of the upper and lower apex seals at two points.

Standard height: 8.0mm (0.315 in)
Height: 6.5mm (0.256 in) min.

Note

Replace the short apex seal spring if the apex seal height is below 7.5mm (0.295 in).

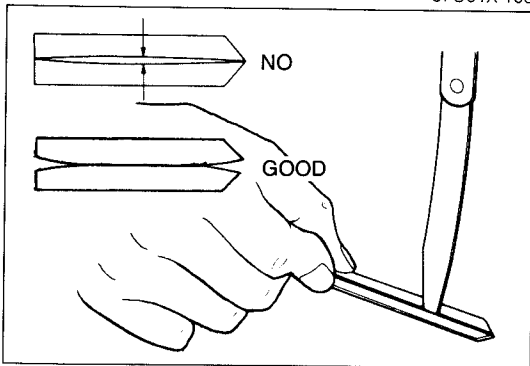

97U0CX-098

3. Check the apex seals for warpage. Put two apex seals together, top-to-top, and check the warpage. Do this with all three seals. If the warpage exists in the middle of the seals, replace the apex seals. If the warpage exists in the ends of the seals, the seal can be used.

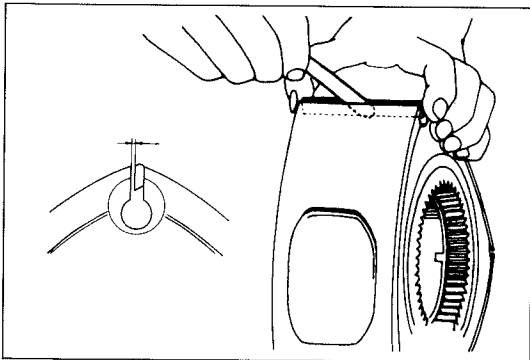

97U0CX-099

4. Check the clearance of the apex seal and the groove. Place the apex seal in its respective groove in the rotor, and measure the apex seal clearance. If necessary, replace it.

Standard clearance:

Turbo: 0.041—0.091mm (0.0016—0.0036 in)
Non-Turbo: 0.052—0.092mm (0.0020—0.0036 in)
Clearance: 0.15mm (0.0059 in) max.

5. Check the apex seal spring for wear and free height. If necessary, replace it.

Free height:

Long spring: 4.6mm (0.181 in) min.
Short spring: 1.7mm (0.067 in) min.

Note

Replace the short apex seal spring, if the apex seal height is below 7.5mm (0.295 in).

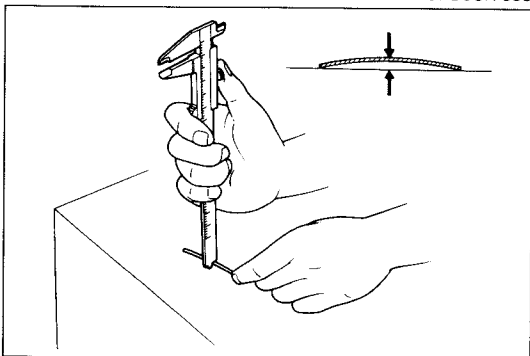

97U0CX-214

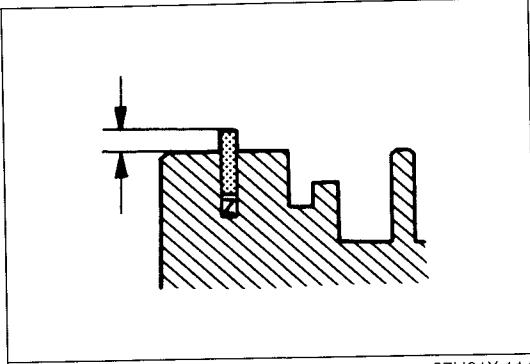

67U01X-114

Side Seal

1. Inspect the side seal for wear or damage, if necessary replace it.
2. Install the side seal spring and side seal into their respective grooves.
3. Check the side seal for vertical free movement.
4. Check the side seal protrusion.

Protrusion: 0.5mm (0.020 in) min.

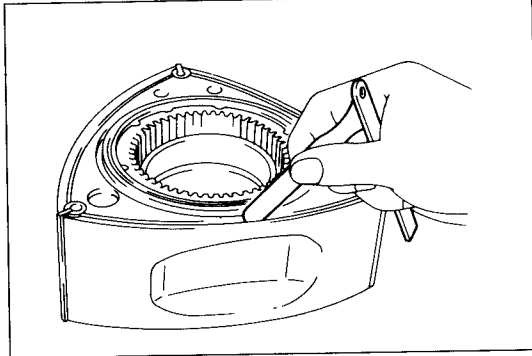

67U01X-115

5. Check the clearance between the side seal and the groove.

Standard clearance:

0.028—0.078mm (0.0011—0.0031 in)

Clearance: 0.10mm (0.0039 in) max.

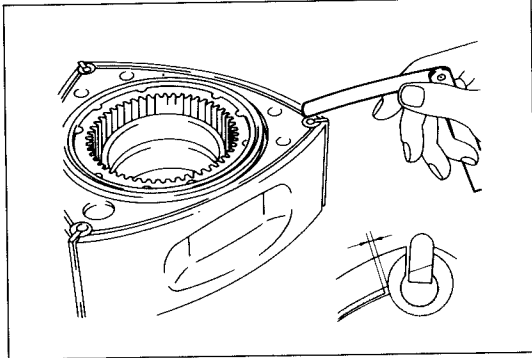

97U0CX-100

6. Check the clearance between the side seal and the corner seal.

Standard clearance:

0.05—0.15mm (0.0020—0.0059 in)

Clearance: 0.40mm (0.016 in) max.

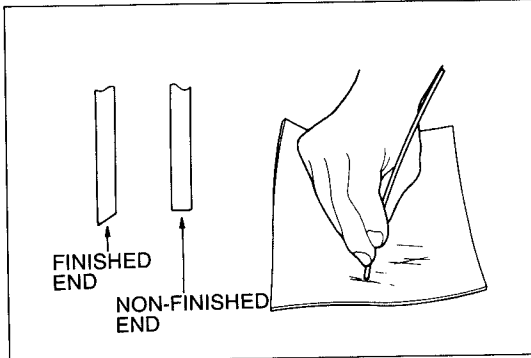

67U01X-117

7. If necessary, replace the side seal.

Adjust the clearance between the side seal and corner seal by lapping the non-finished end carefully.

Adjusted clearance:

0.05—0.15mm (0.002—0.0059 in)

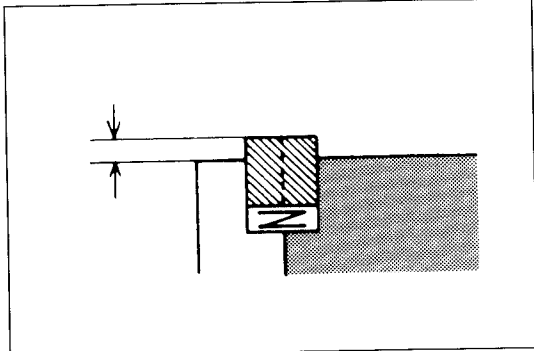

67U01X-118

Corner Seal

1. Inspect the corner seal and soft seal for wear, cracks, or any other damage. If necessary, replace them.
2. Install the corner seal spring and corner seal into its respective groove.
3. Check the corner seal for vertical free movement.
4. Check the corner seal protrusion.

Protrusion: 0.5mm (0.020 in) min.

If necessary, replace the corner seal and/or the spring.

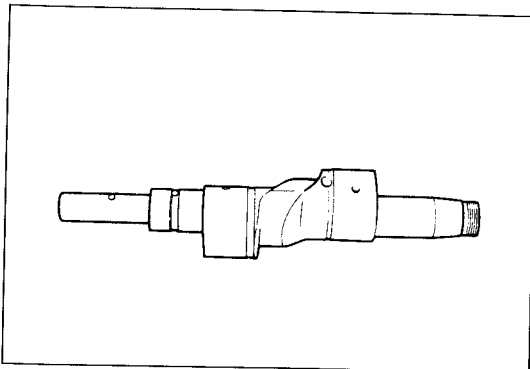

67U01X-119

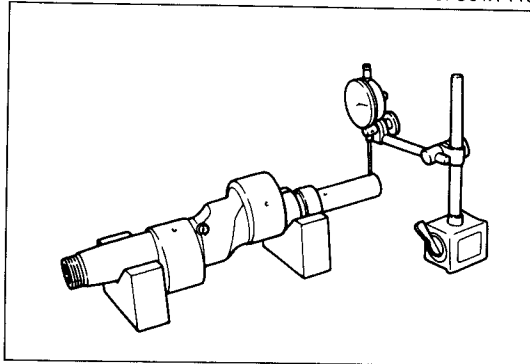

67U01X-120

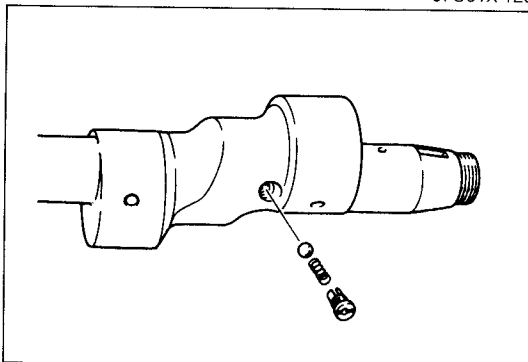

97U0CX-101

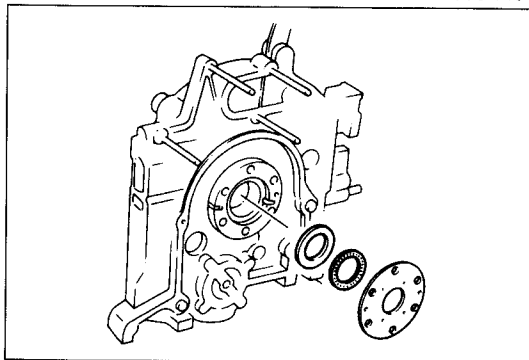

67U01X-122

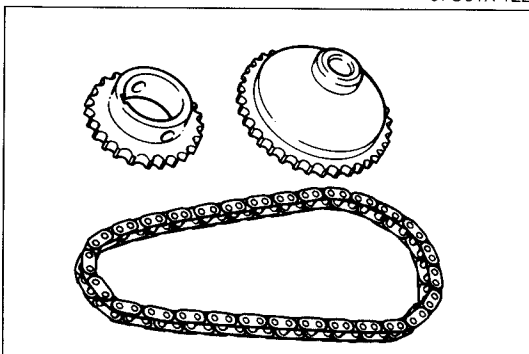

67U01X-123

Eccentric Shaft

1. Check the eccentric shaft for cracks, scoring, wear, or any other damage.
2. Check that the oil passages are open.

3. Check the eccentric shaft runout. Measure the run-out at the end of the shaft, replace it if necessary.

Runout: 0.12mm (0.0047 in) max.

4. Check the oil jet spring for weakness, and for sticking or damage of the steel ball.

Needle Bearing and Thrust Plate

1. Check the needle bearing for wear or damage.
2. Check the bearing housing and thrust plate for wear or any other damage.

Oil Pump Drive Chain and Sprocket

1. Check the oil pump drive chain for broken links.
2. Check the oil pump drive sprocket and driven sprocket for cracks and worn or damaged teeth. If necessary, replace with new parts.

ASSEMBLY

PREPARATION SST

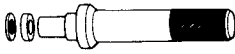
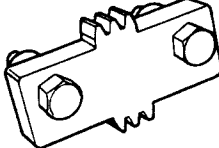
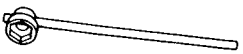
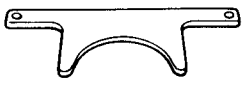
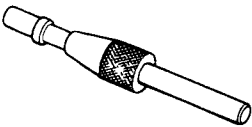
<p>49 0823 072A</p> <p>Needle bearing installer</p> 	<p>49 F011 101</p> <p>Ring gear brake</p> 	<p>49 0820 035</p> <p>Flywheel box wrench</p> 
<p>49 1881 055</p> <p>Counter weight stopper</p> 	<p>49 SE01 310</p> <p>Clutch disc centering tool</p> 	<p>97U0CX-102</p>

1. Clean all parts before reinstallation.
2. Apply new engine oil to all sliding and rotating parts.
3. Install identical parts (such as rotor seals, seal springs, rotor oil seals, and rotor) in the exact positions from which they were removed.
4. Replace plain bearings if they are peeling, burned, or otherwise damaged.
5. Tighten all bolts and nuts to the specified torques.

Caution

Do not reuse gaskets or oil seals.

97U0CX-103

MAIN PARTS

Install the main parts in the manner described from page C-50.

Component 1 — Housing Related Parts

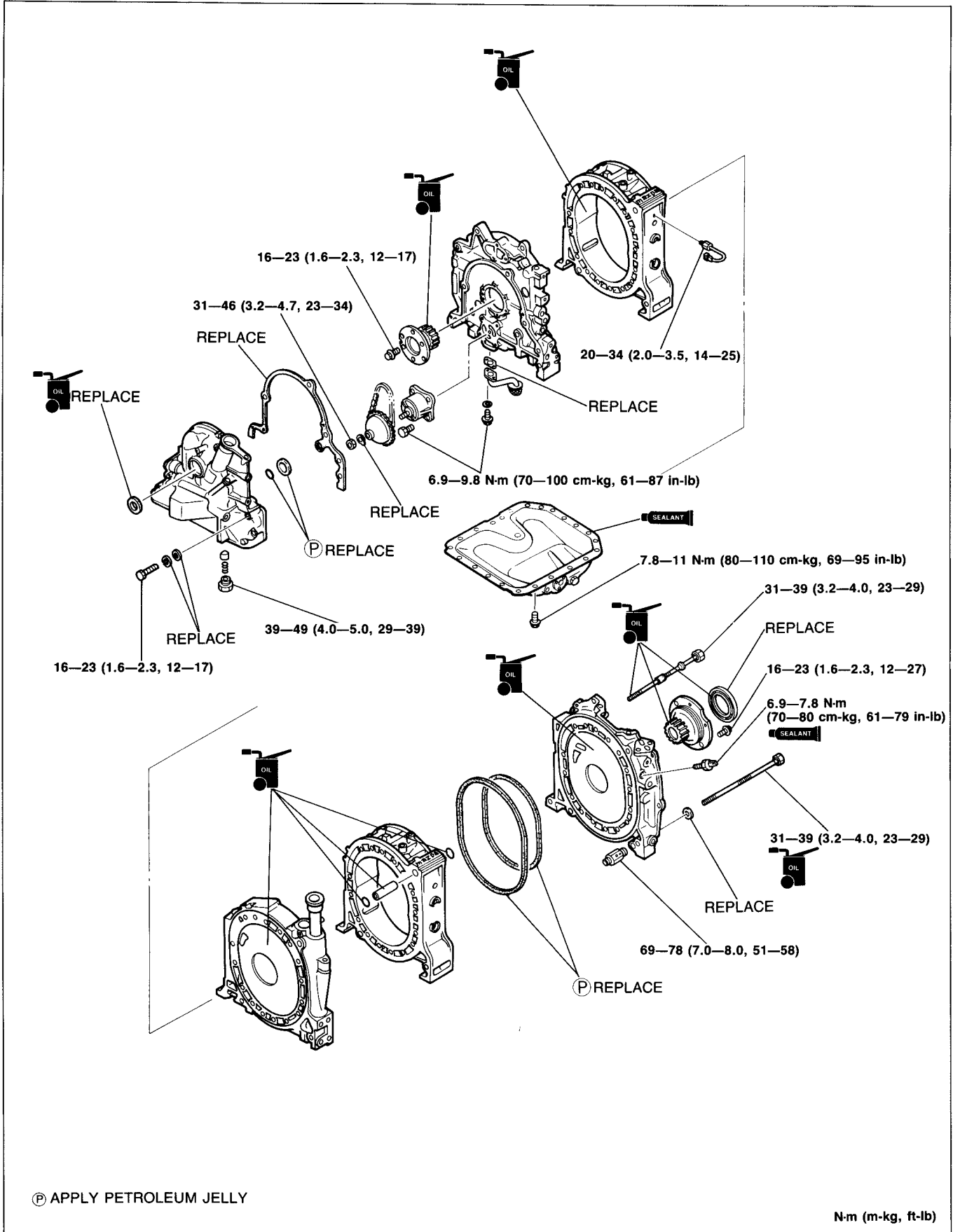

Component 2 — Rotating Related Parts

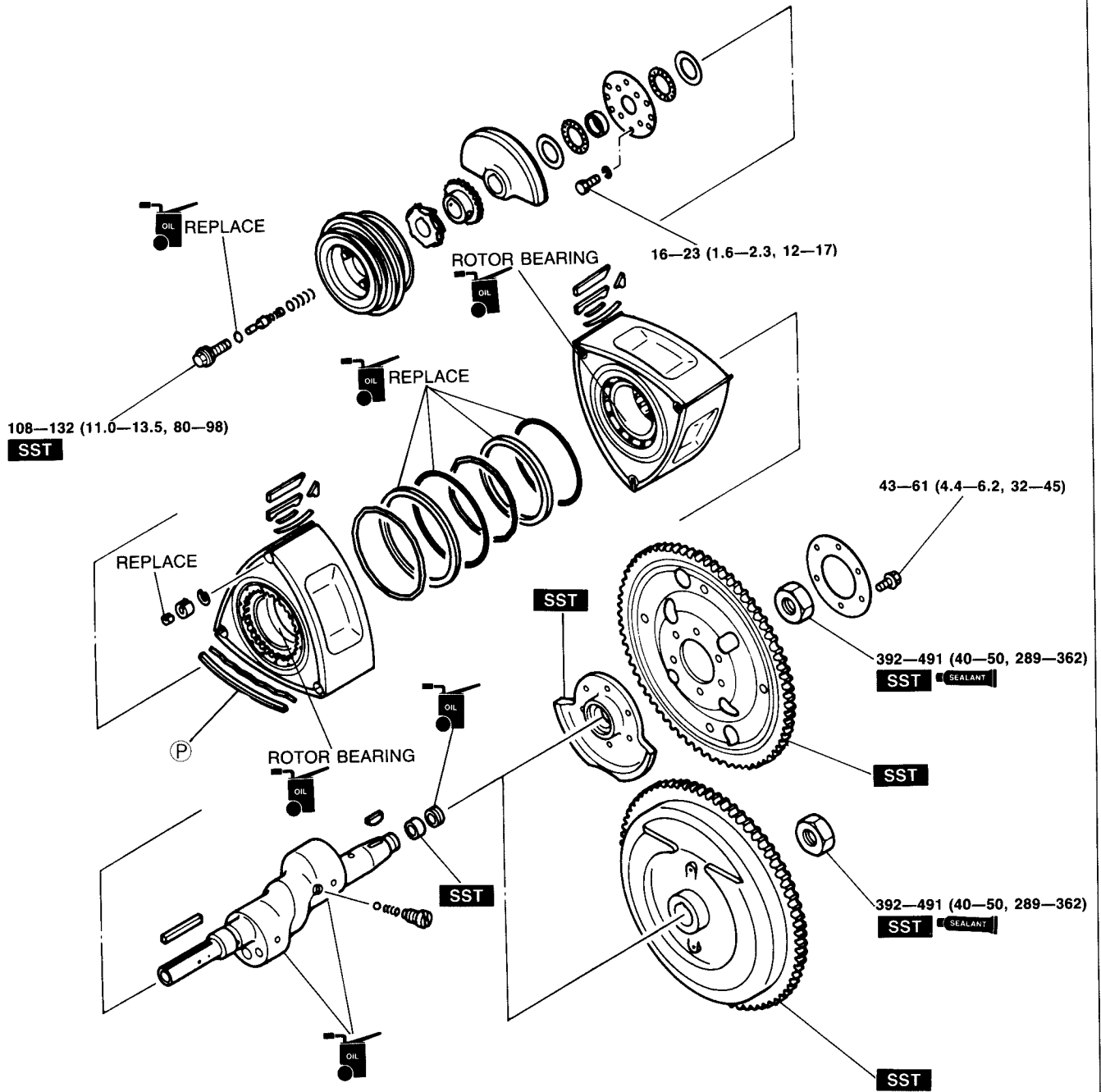

N-m (m-kg, ft-lb)

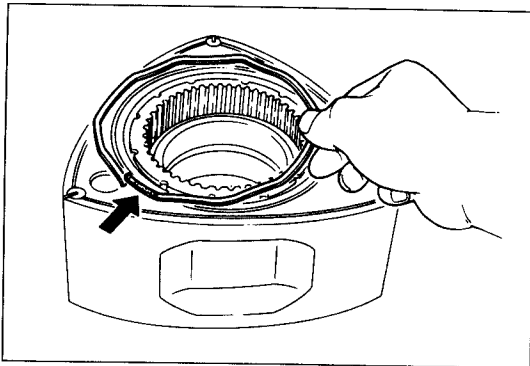

97U0CX-106

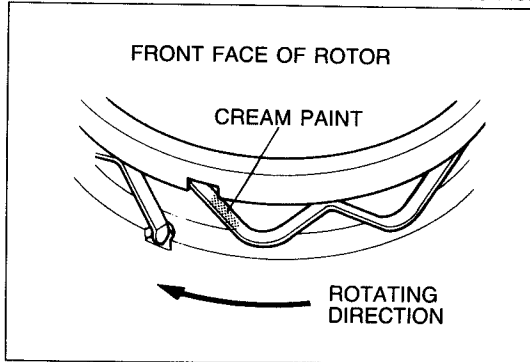

67U01X-126

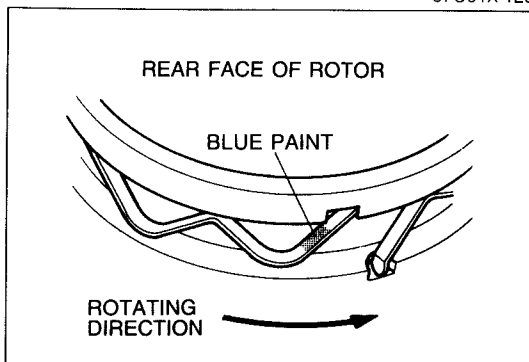

97U0CX-107

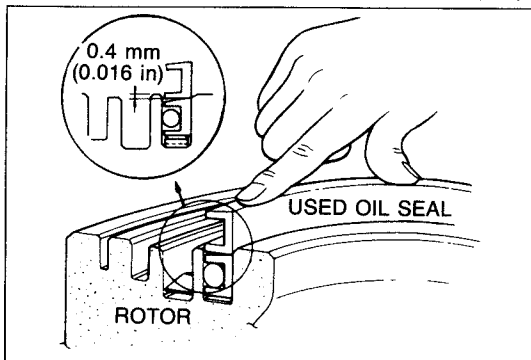

97U0CX-108

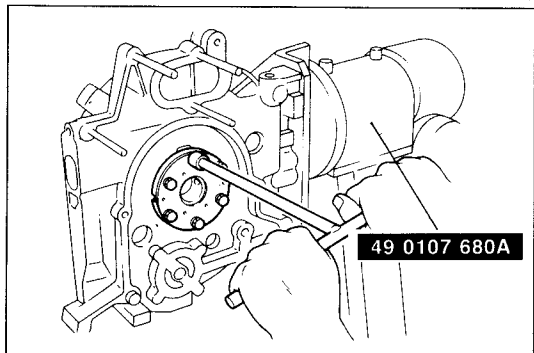

97U0CX-109

Rotor Oil Seal

Note

a) When replacing the oil seal, first make sure that it moves smoothly in the groove without the O-ring in place.

b) Be careful not to deform the lip of the oil seal.

1. Install the oil seal springs in their respective grooves on the rotor with the round edge of the spring fitted in the stopper hole of the oil seal grooves.

Note

The oil seal springs are identified by a painted mark.
Cream springs.... for front faces of both front and rear rotors.

Blue springs for rear faces of both front and rear rotors.

2. Apply engine oil to the new O-ring.
3. Install the O-ring in the oil seal.
4. Place the inner oil seal in the oil seal groove so that the square edge of the spring fits into the notch of the oil seal.
5. Press the oil seal with a used oil seal until the lip of the oil seal is approximately **0.4mm (0.016 in)** below the surface of the rotor.
6. Push the oil seal slowly by hand and make sure it moves freely.

Front Housing

1. Mount the front housing to the **engine hanger** (49 L010 1A0) attached to the **engine stand** (49 0107 680A).
2. Position the thrust plate with the chamfer facing toward the front housing. Install the needle bearing and plate.

Tightening torque:

16—23 N·m (1.6—2.3 m·kg, 12—17 ft·lb)

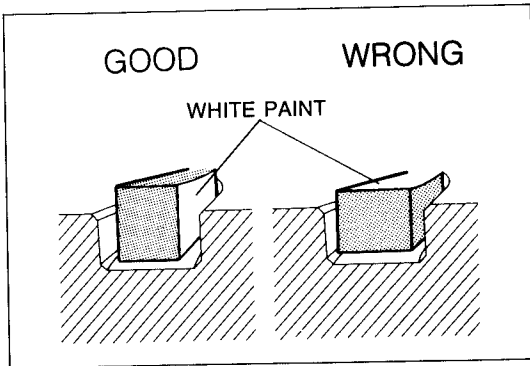

67U01X-130

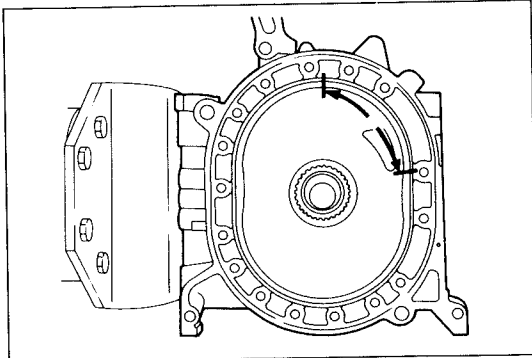

67U01X-131

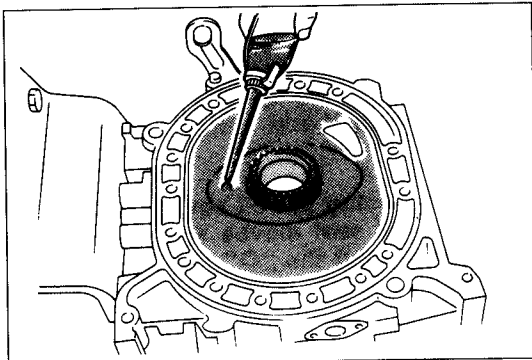

67U01X-132

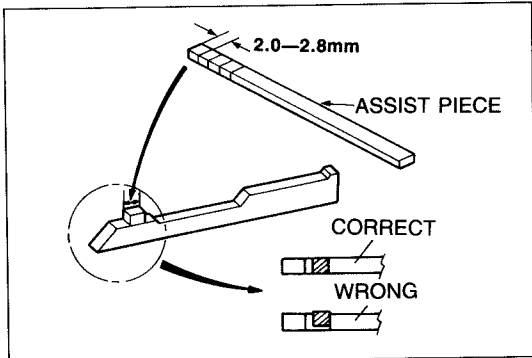

97U0CX-110

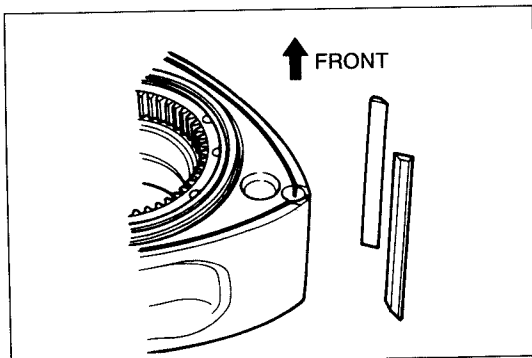

97U0CX-111

3. Apply petroleum jelly to the new outer and inner sealing rubbers.
4. Install the outer sealing rubber so that the white paint faces the side wall in the groove.

5. Install the inner sealing rubber the blue paint faces the outer wall in the groove and so that the seam is placed in position as shown in the figure.
6. Check that both the outer and inner sealing rubbers are not twisted.

7. Apply engine oil to the contact surfaces, stationary gear, and main bearing.

Caution

Do not apply engine oil to the sealing rubber.

Rotor Seals (Front side of rotor)

1. Place the front rotor on a clean rubber pad or cloth with the front side upward.
 2. Cut the assist piece with a knife so that its length becomes to **2.0—2.8mm (0.08—0.11 in)**.
 3. Peel the paper stuck on the assist piece and stick the assist piece on the apex seal.
4. Install the upper and lower apex seals without the spring and side piece into their respective grooves so that the side piece mounting positions to the rear side of the rotor.

Caution

If the apex seals are installed incorrectly, this may result in poor gas sealing performance.

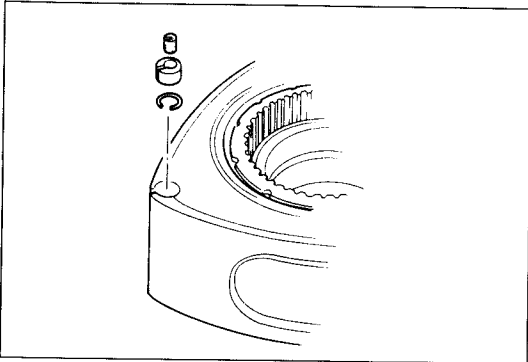

97U0CX-112

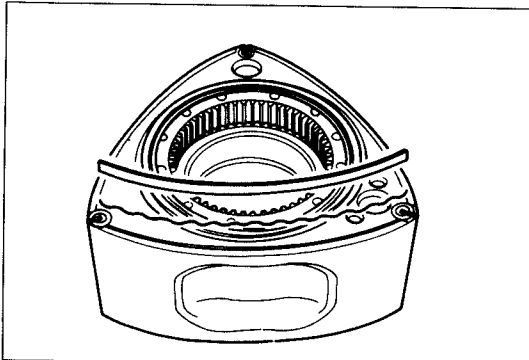

97U0CX-113

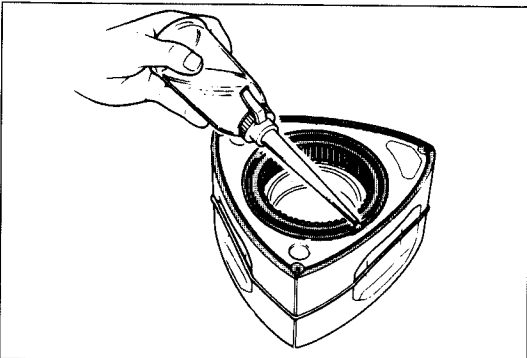

67U01X-136

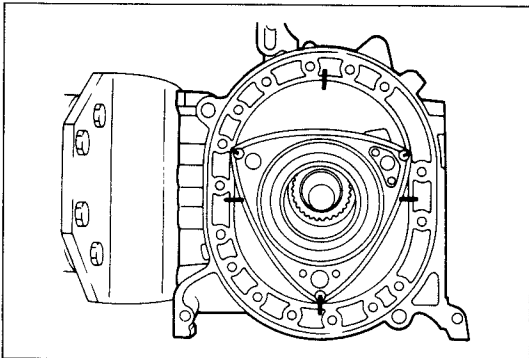

67U01X-137

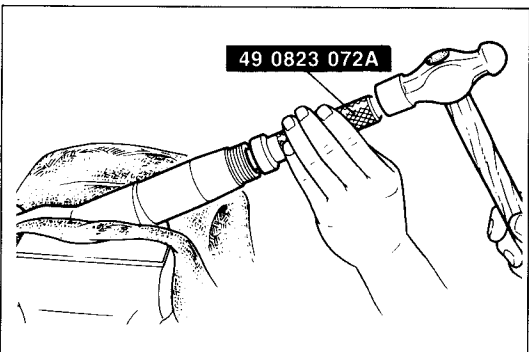

97U0CX-114

5. Install the new soft seals into the corner seals.
6. Install the corner seal springs and corner seals so that the chamfer surface faces the bottom of the groove.

7. Install the side seal springs and side seals so that the paint faces the bottom of the groove.
8. Confirm smooth movement of the corner seals and side seals by lightly pressing them.
9. Apply petroleum jelly to the side seals.

Front Rotor

1. Apply engine oil to the rotor oil seal, rotor bearing, and internal gear.

2. Place the front rotor in the front housing, and mesh the internal gear and stationary gear so that one of the rotor apexes is set to one of the four positions illustrated.

Caution

Do not place the rotor on the sealing rubber.

Eccentric Shaft

1. Tap in the needle bearing into the eccentric shaft with the **SST**, until the **SST** touches the blind plug.
2. Apply grease to the needle bearing.
3. Apply engine oil to the oil seal lip.

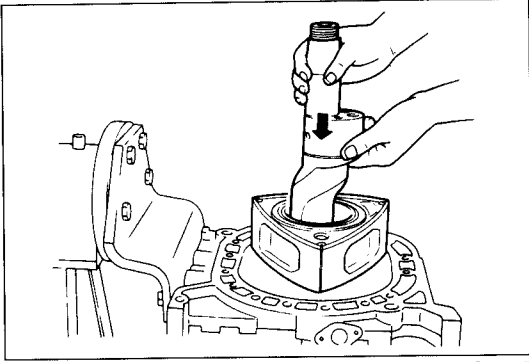

97U0CX-115

4. Apply engine oil to the front rotor journal and main journal.
5. Insert the eccentric shaft, being careful not to damage the rotor bearing or main bearing.

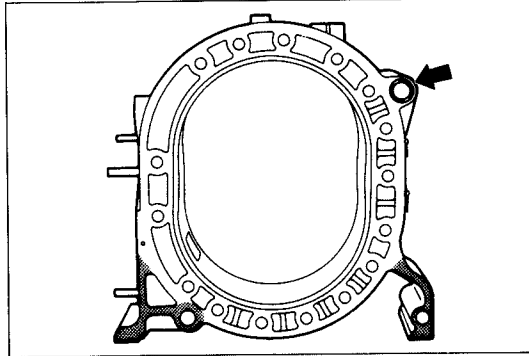

77U01X-122

Front Rotor Housing

1. Apply petroleum jelly to the new O-ring, and install it to the rotor housing.
2. Apply a coat of sealant on the rotor housing front side, as shown on the shaded area in the figure.

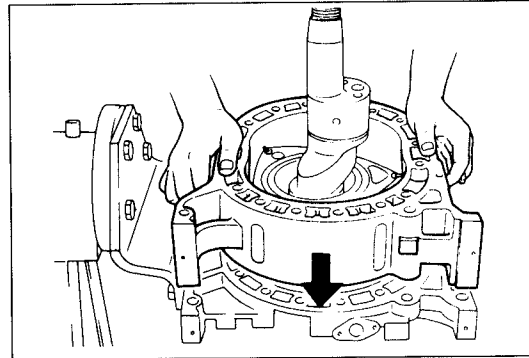

77U01X-123

3. Apply engine oil to the trochoid surface of the rotor housing.
4. Install the rotor housing.

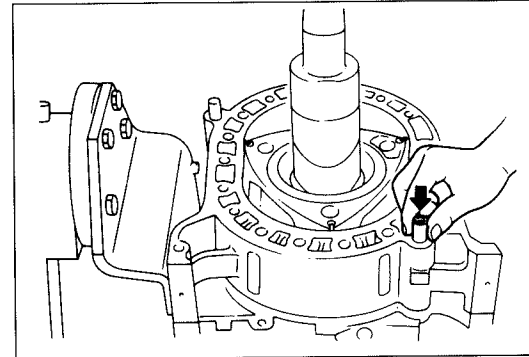

77U01X-124

5. Apply engine oil to the tubular dowels and insert them through the front rotor housing holes into the front housing holes.

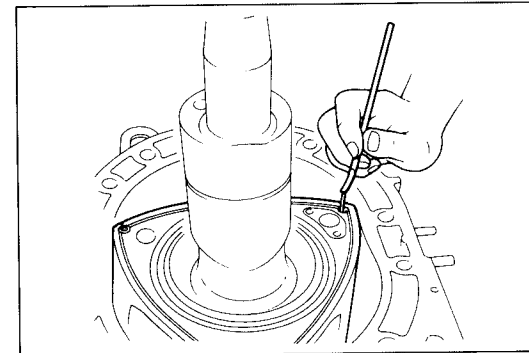

67U01X-142

Rotor Seals (Rear side of rotor)

1. Insert the short apex seal springs.

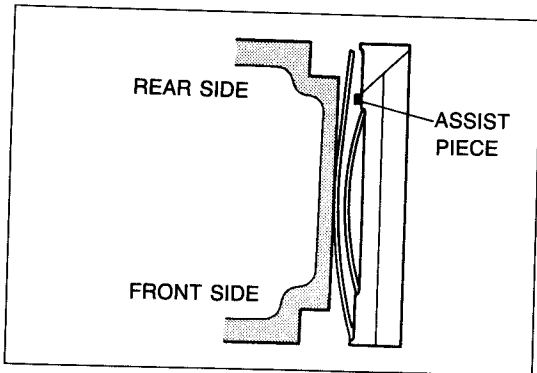

97U0CX-116

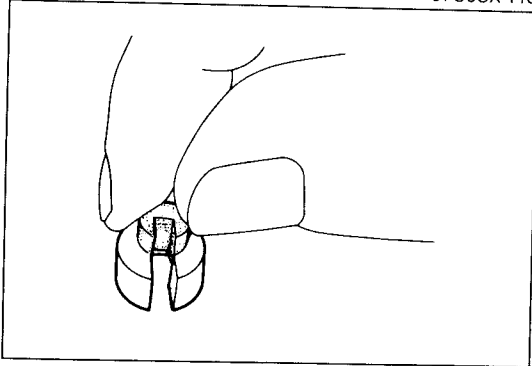

97U0CX-117

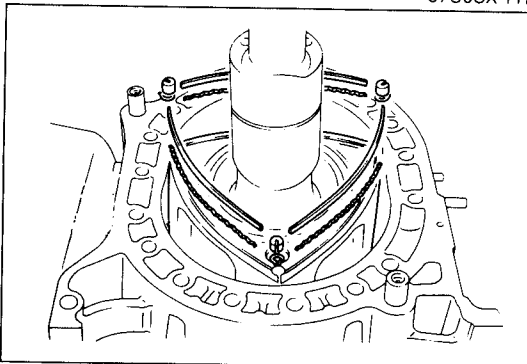

97U0CX-118

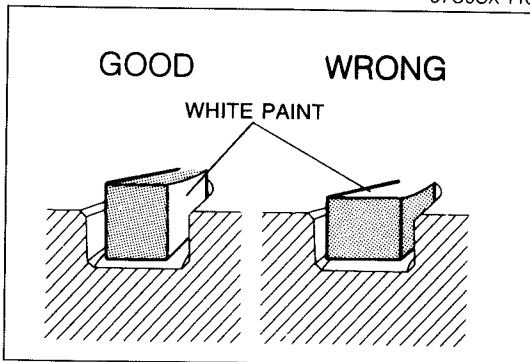

67U01X-146

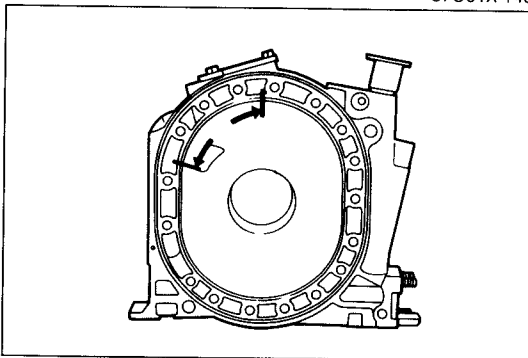

67U01X-147

2. Insert the long apex seal springs.
3. Fit the each side piece to its original position and confirm that the springs are set correctly on the side piece.
4. Confirm the smooth movement of each seal by pressing its head.

5. Install the new soft seals into the corner seals.
6. Install the corner seal springs and corner seals so that the chamfer surface faces the bottom of the groove.

7. Install the side seal springs and side seals so that the paint faces the bottom of the groove.
8. Confirm smooth movement of the corner seals and side seals by lightly pressing them.

Intermediate Housing

1. Apply petroleum jelly to the new outer and inner sealing rubbers.
2. Install the outer sealing rubber to the front side so that the white paint faces the side wall in the groove.

3. Install the inner sealing rubber to the front side so that the blue paint faces the outer wall in the groove and the seam is placed in position as shown in the figure.
4. Check that both the outer and inner sealing rubbers are not twisted.

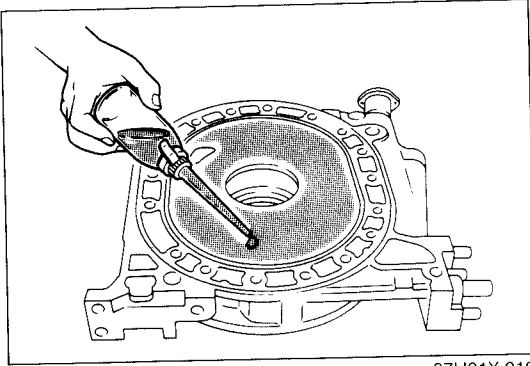

87U01X-010

5. Apply engine oil to the contact surfaces of the intermediate housing.

Caution

Do not apply engine oil to the sealing rubber.

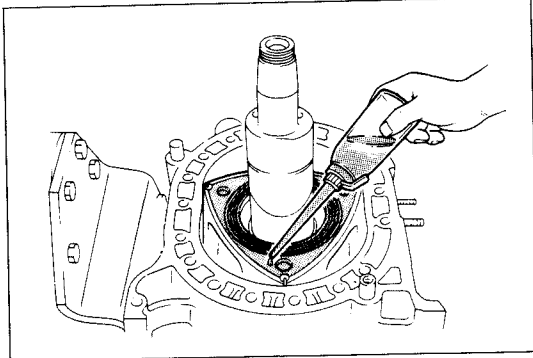

67U01X-149

6. Apply engine oil to the rotor oil seal on the rear side of the front rotor.

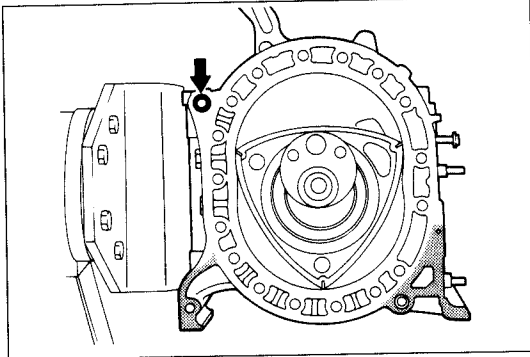

97U0CX-119

7. Apply petroleum jelly to a new O-ring, and install it on the rotor housing.
8. Apply a coat of sealant to the shaded area as shown in the figure.

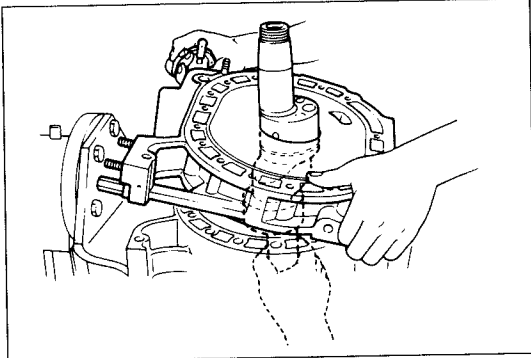

97U0CX-120

9. Turn the eccentric shaft so that the rear rotor journal faces the intake and exhaust side.
10. Lift the eccentric shaft about **25mm (1.0 in)**, and install the intermediate housing over the eccentric shaft on to the front rotor housing.

Note

Do not lift the shaft over 35mm (1.4 in).

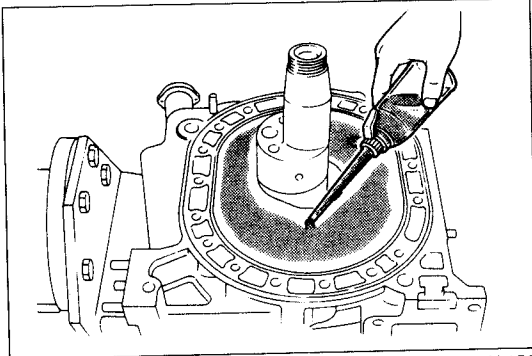

67U01X-152

11. Install the outer and inner sealing rubber to the rear side of the intermediate housing using the same method applied to the front side of the intermediate housing.
12. Apply engine oil to the rear contact surfaces.

Caution

Do not apply engine oil to the sealing rubber.

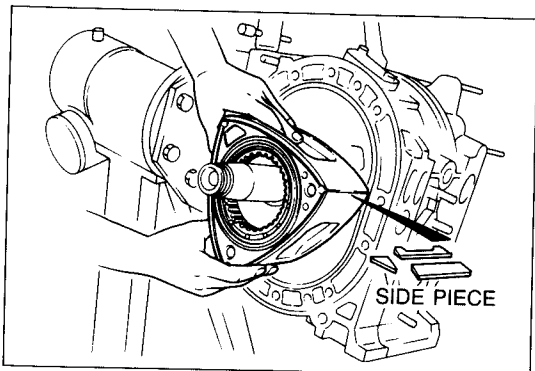

97U0CX-121

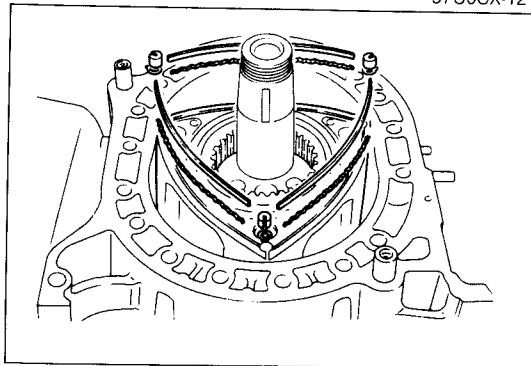

97U0CX-122

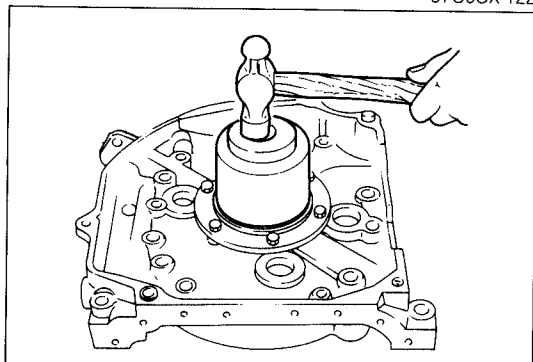

67U01X-155

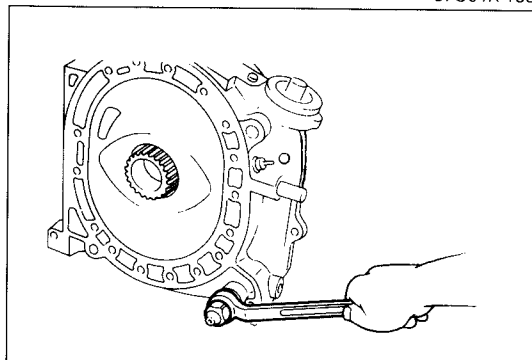

97U0CX-123

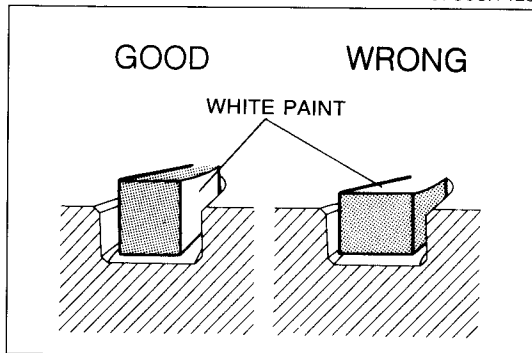

67U01X-157

Rear Rotor, Rotor Seals, and Rear Rotor Housing

Install the rotor seals, rear rotor, and rear rotor housing in the same procedure as the installation of the rotor seals, front rotor, and front rotor housing.

1. Install the rotor seals and rear rotor.
(Refer to page C-51.)

Caution

The side piece of the rotor seal must face the rear housing side.

2. Install the rear rotor housing. (Refer to page C-53.)
3. Install the tubular dowel pins.
4. Install the rotor seals at the rear side of the rotor.
(Refer to page C-53.)

Rear Housing

1. Apply engine oil to the new rear oil seal and the groove of the rear stationary gear.
2. Install the oil seal into the rear stationary gear.

3. Install the oil regulator valve.

Tightening torque:

69—78 N·m (7.0—8.0 m·kg, 51—58 ft·lb)

4. Apply petroleum jelly to the new outer and inner sealing rubbers.
5. Install the outer sealing rubber so that the white paint faces the side wall in the groove.

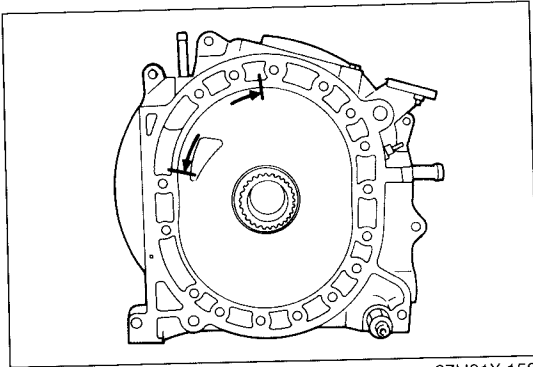

67U01X-158

6. Install the inner sealing rubber so that the blue paint faces the outer wall in the groove and the seam is placed in position as shown in the figure.
7. Check that both the outer and inner sealing rubbers are not twisted.

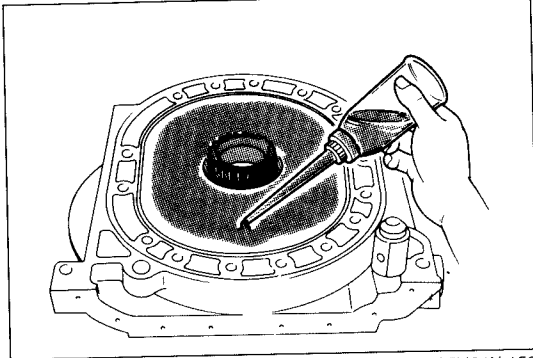

67U01X-159

8. Apply engine oil to the contact surfaces, stationary gear, and main bearing.

Caution
Do not apply engine oil to the sealing rubber.

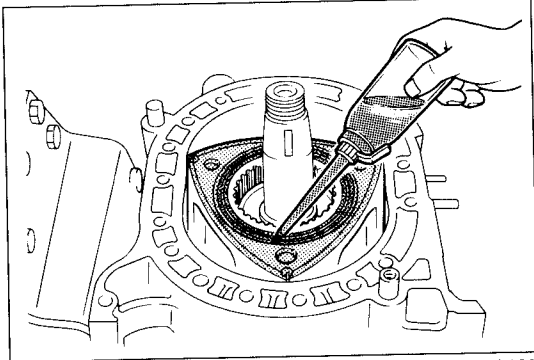

67U01X-160

9. Apply engine oil to the rotor oil seal of the rear rotor's rear side.

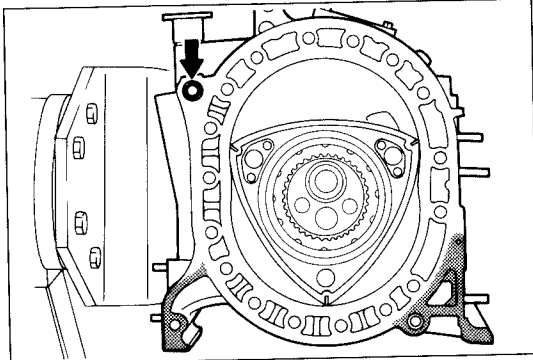

97U0CX-124

10. Apply petroleum jelly to the new O-ring, and fit it into the rear rotor housing.
11. Apply a coat of sealant to the shaded area as shown in the figure.

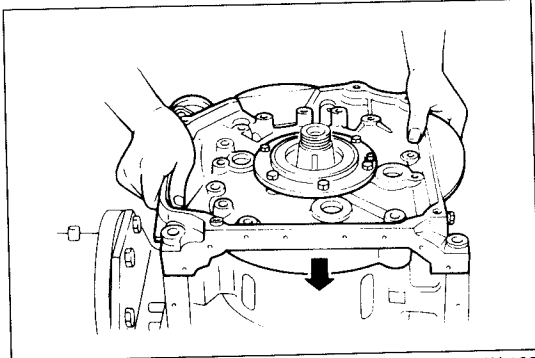

67U01X-162

12. Install the rear housing on the rear rotor housing.
13. Check that the side pieces of the front and rear apex seals are not wedged between the rotor housing and side housing.

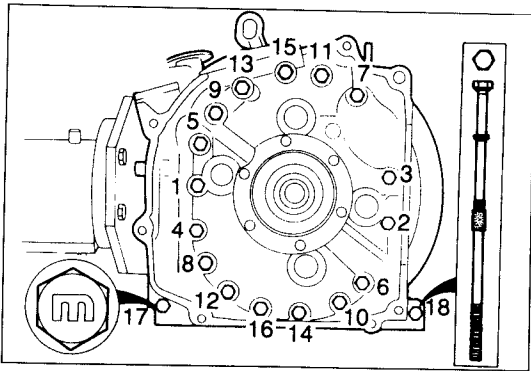

97U0CX-125

Tension Bolt

1. Apply engine oil to the new seal washers and install them on the tension bolts.
2. Apply engine oil to the bolt threads.
3. Install the tension bolts and tighten them gradually in the order shown in the figure.

Tightening torque:

31—39 N·m (3.2—4.0 m·kg, 23—29 ft·lb)

Note

- a) The bolt with the mark is for the No.17 position.
- b) The bolt with the tube is for the No.18 position.

4. Turn the eccentric shaft and make sure that the rotation is easy and smooth.

Flywheel (M/T)

1. Apply engine oil to the oil seal in the rear housing.
2. Fit the key to the eccentric shaft.
3. Install the flywheel to the eccentric shaft.

4. Apply thread locking compound to the eccentric shaft threads.
5. Apply sealant to the contact surface of the locknut.

6. Install locknut and tighten using the SST.

Tightening torque:

392—491 N·m (40—50 m·kg, 289—362 ft·lb)

Counter Weight and Drive Plate (A/T)

1. Apply engine oil to the oil seal in the rear housing.
2. Fit the key to the eccentric shaft.
3. Install the counter weight to the eccentric shaft.

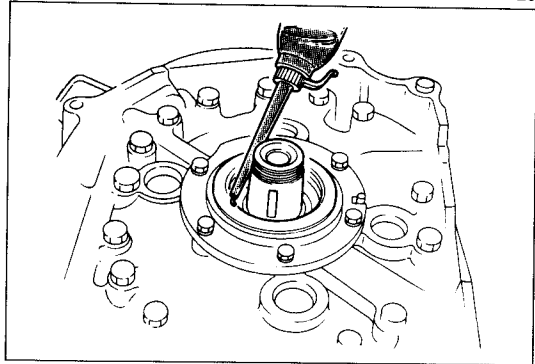

97U0CX-126

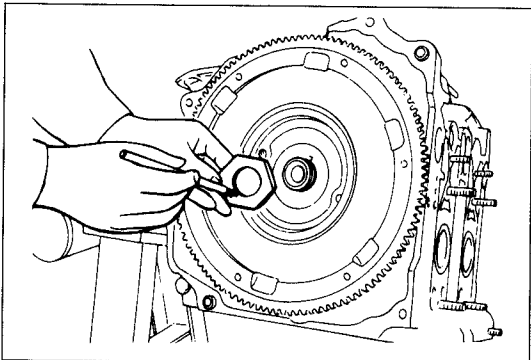

97U0CX-127

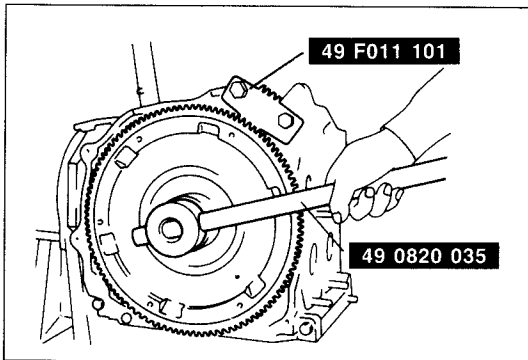

97U0CX-128

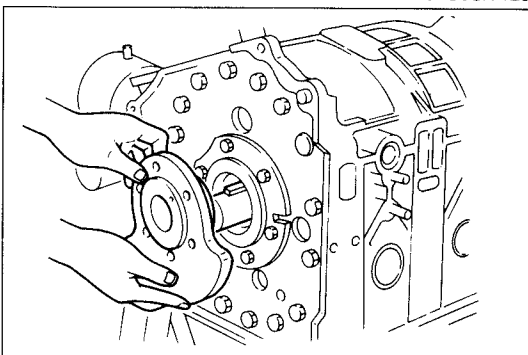

97U0CX-129

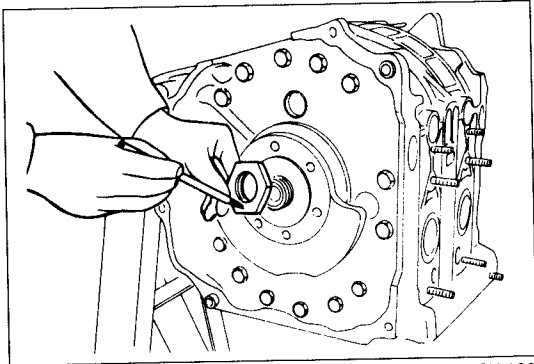

97U0CX-130

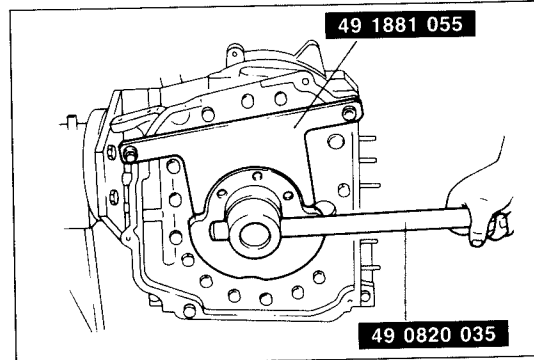

97U0CX-131

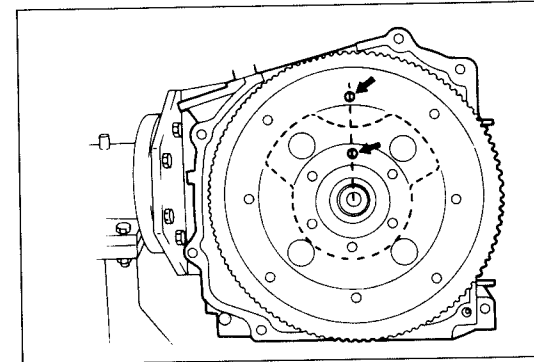

67U01X-170

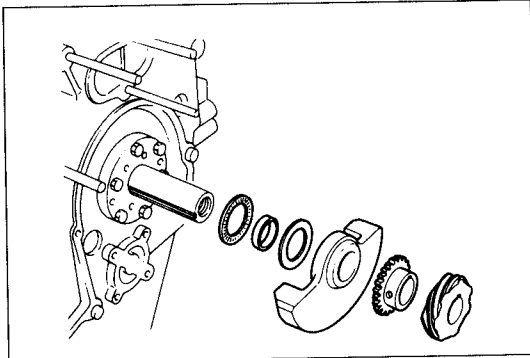

67U01X-171

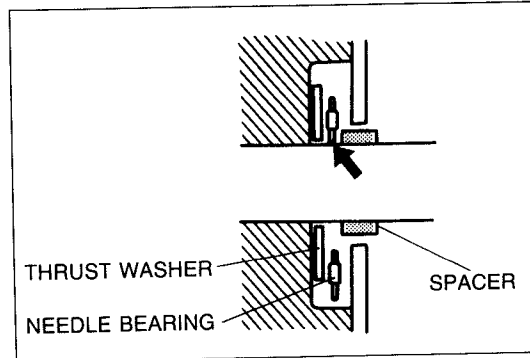

97U0CX-132

4. Apply thread locking compound to the eccentric shaft threads.
5. Apply sealant to the contact surface of the locknut.

6. Install locknut and tighten using the **SST**.

Tightening torque:
392—491 N·m (40—50 m·kg, 289—362 ft·lb)

7. Install the drive plate so that the holes in the drive plate and counter weight are positioned as shown in the figure. Install the back plate and tighten.

Tightening torque:
43—61 N·m (4.4—6.2 m·kg, 32—45 ft·lb)

Balance Weight, Bearing, and Spacer

1. Install the following parts to the eccentric shaft:
 - (1) Spacer
 - (2) Thrust needle bearing
 - (3) Thrust washer
 - (4) Balance weight
 - (5) Oil pump drive sprocket
 - (6) Distributor drive gear

Caution

When installing the needle bearing, make sure it is not caught by the spacer.

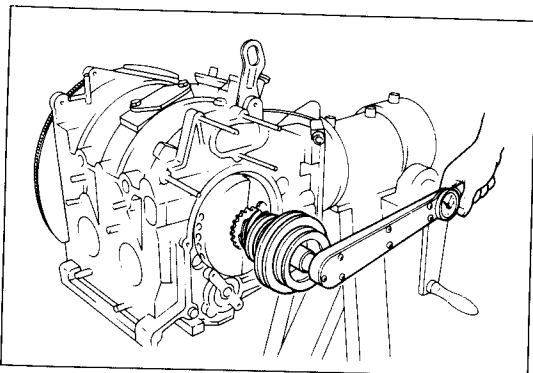

97U0CX-133

2. Install the eccentric shaft pulley boss and tighten the pulley lock bolt.

Tightening torque:
108—132 N·m (11.0—13.5 m·kg, 80—98 ft·lb)

3. Remove the **SST**.

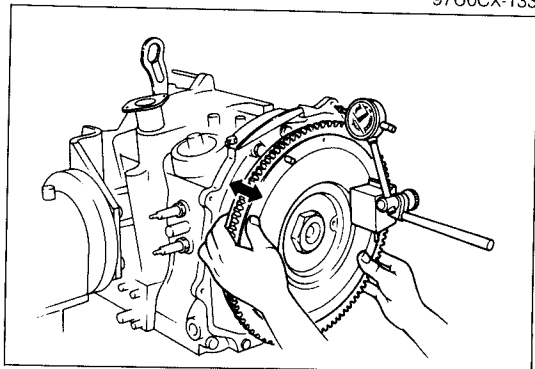

97U0CX-134

4. Measure the end play of the eccentric shaft.

Standard end play:
0.040—0.070mm (0.0016—0.0028 in)
End play: 0.09mm (0.0035 in) max.

If necessary replace the spacer, continuing with step 5.

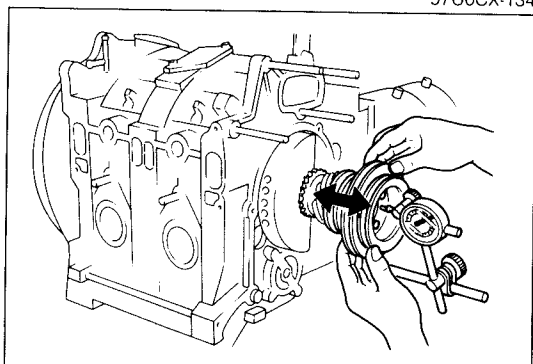

67U01X-175

5. Attach the **SST** to the flywheel (M/T), or attach the **SST** to the counterweight (A/T).
6. Remove the eccentric shaft lock bolt, distributor drive gear and oil pump drive sprocket.

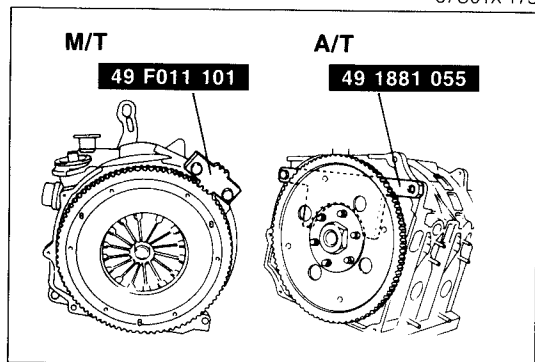

97U0CX-135

7. If the end play is less than specified, replace the spacer with a thicker one. If the end play is more than specified, replace the spacer with a thinner one.

Spacer stamp and thickness

Stamp	Thickness mm (in)	Stamp	Thickness mm (in)
S	8.12 (0.3197)	Y	8.04 (0.3165)
T	8.10 (0.3189)	V	8.02 (0.3157)
X	8.08 (0.3181)	Z	8.00 (0.3150)
K	8.06 (0.3173)		

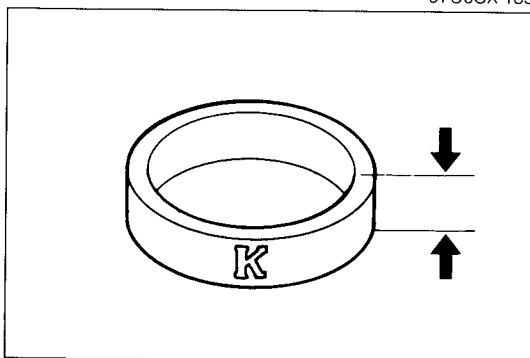

77U01X-125

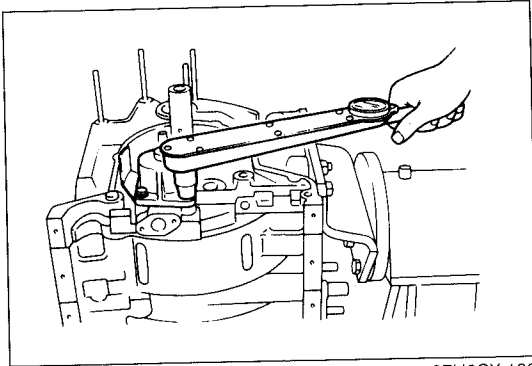

97U0CX-136

Oil pump

1. Apply engine oil to the oil pump shaft.
2. Install the oil pump to the front housing.

Tightening torque:

6.9—9.8 N·m (70—100 cm·kg, 61—87 in·lb)

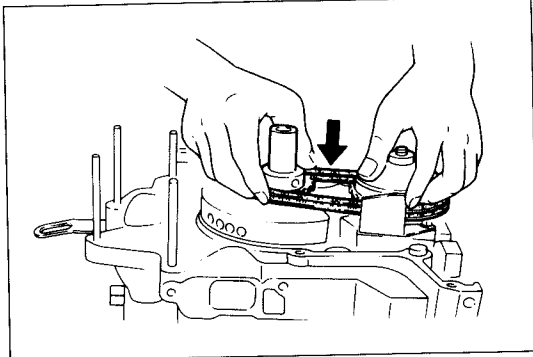

67U01X-179

3. Install the key to the oil pump shaft.
4. Install the oil pump drive gear, driven gear, and drive chain as an assembly.

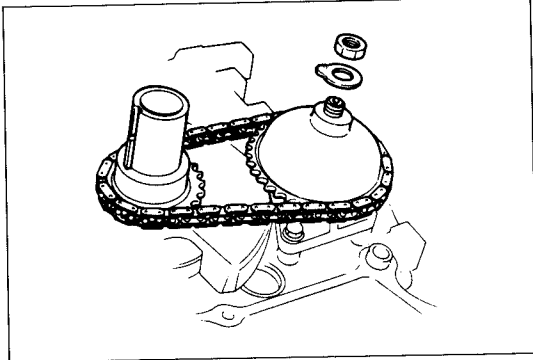

97U0CX-137

5. Install the key to the eccentric shaft.
6. Install the new washer and oil pump locknut.

Tightening torque:

31—46 N·m (3.2—4.7 m·kg, 23—34 ft·lb)

7. Bend the washer to lock the nut.

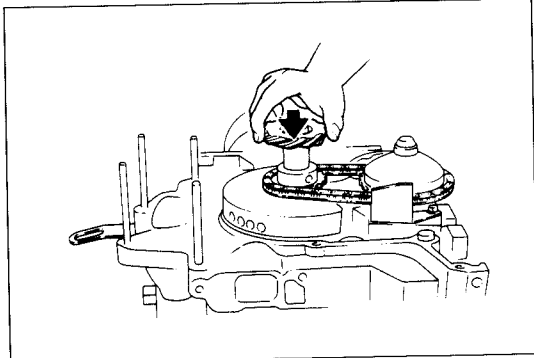

67U01X-181

8. Install the distributor drive gear so that the chamfer surface faces the housing.

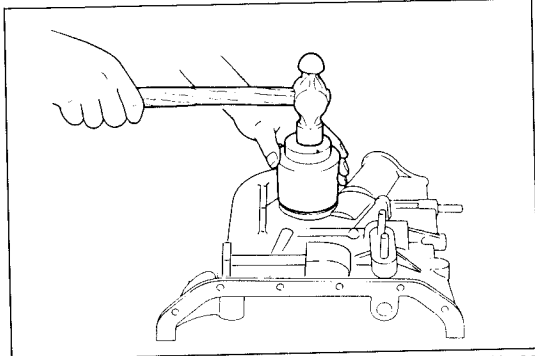

67U01X-182

Front Cover

1. Apply engine oil to the new front oil seal and the groove of the front cover.
2. Install the oil seal in the front cover.

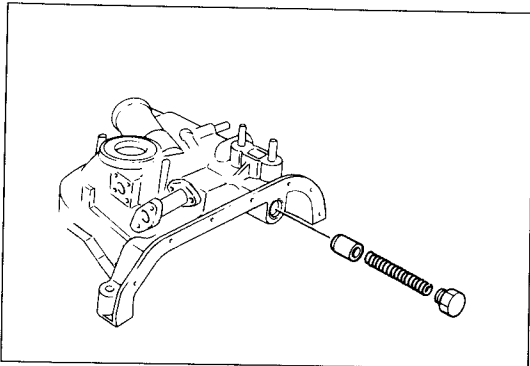

67U01X-183

3. Install the oil pressure control valve in the front cover.

Tightening torque:

39—49 N·m (4.0—5.0 m·kg, 29—36 ft·lb)

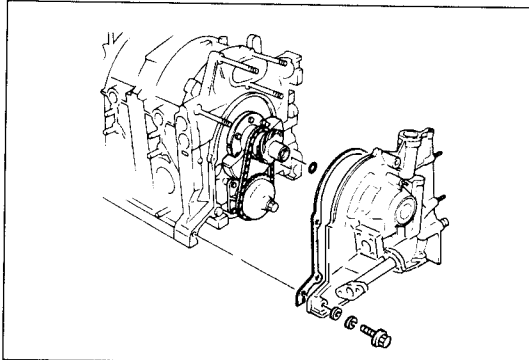

97U0CX-215

4. Apply petroleum jelly to the new O-ring and backup ring and install it on the front cover with a new gasket.

Tightening torque:

16—23 N·m (1.6—2.3 m·kg, 12—17 ft·lb)

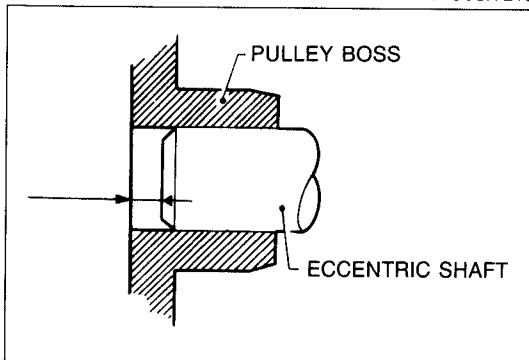

97U0CX-138

Eccentric Shaft Lock Bolt and Bypass Valve

1. Install the eccentric shaft pulley boss.
2. Temporarily install the lock bolt, and tighten it by hand.
3. Remove the lock bolt, and measure the pulley boss protrusion. If it is over the limit, the needle bearing may be caught by the spacer. Remove and reinstall the needle bearing, if necessary.

Protrusion: 2.44mm (0.0961) max.

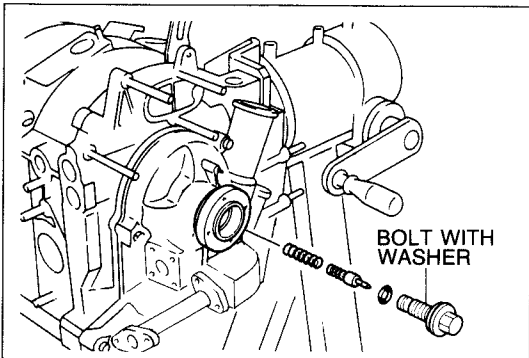

97U0CX-139

4. Install the bypass valve and spring into the eccentric shaft.
5. Apply engine oil to the new O-ring and install it on the lock bolt.
6. Apply a coat of sealant to the flange face of the lock bolt.
7. Install the new lock bolt.

Tightening torque:

108—132 N·m (11—13.5 m·kg, 80—98 ft·lb)

Oil Strainer

Install the oil strainer and a new gasket.

Tightening torque:

6.9—9.8 N·m (70—100 cm·kg, 61—87 in·lb)

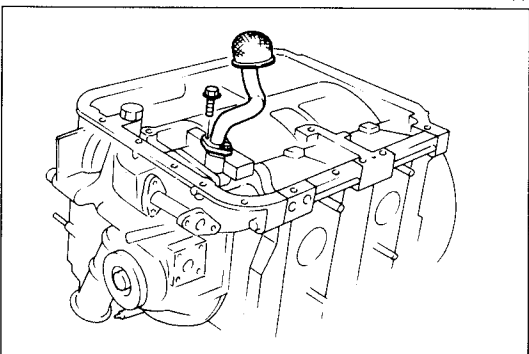

97U0CX-140

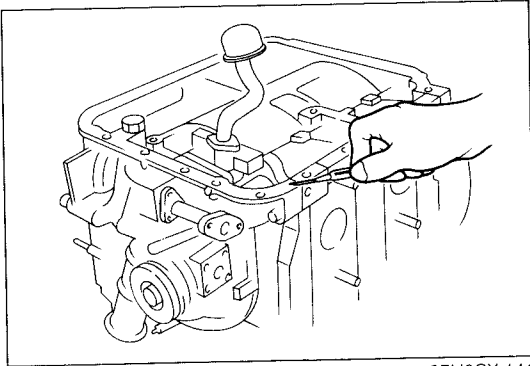

97U0CX-141

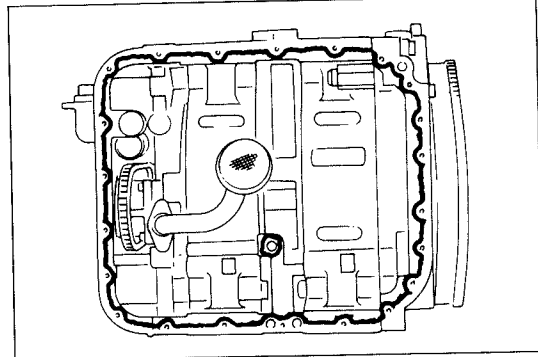

97U0CX-142

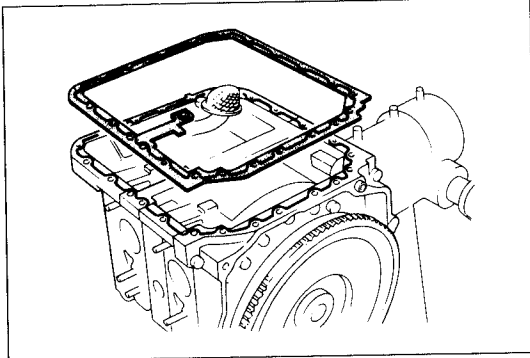

97U0CX-143

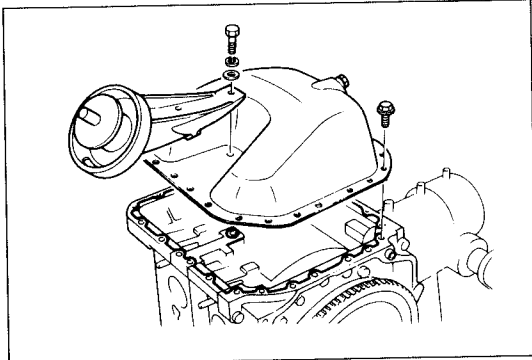

97U0CX-144

Oil Pan

1. Cut away the part of the gasket that projects from between the front cover and the housing.

2. Clean the mating surface of the housing and oil pan.

3. **(Without gasket)**

Apply a **4—6mm (0.16—0.24 in)** diameter bead of **sealant** around the inside edge of the housing as shown in the figure. It should be continuously applied inboard of the bolt holes, and the ends should overlap.

(With gasket)

Apply a **4—6mm (0.16—0.24 in)** diameter bead of **sealant** around the inside edge of the oil pan and the housing side of the new gasket. It should be continuously applied inboard of the bolt holes, and the ends should overlap.

Caution

Install the oil pan within 30 minutes after the sealant is applied.

4. Install the oil pan and the right engine mount, and tighten the bolts gradually.

Oil pan bolt tightening torque:

7.8—11 N·m (80—110 cm·kg, 69—95 in·lb)

Engine mount bolt tightening torque:

63—93 N·m (6.4—9.5, 46—69 ft·lb)

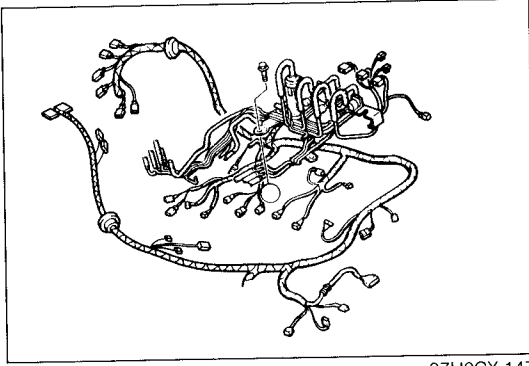

97U0CX-147

Engine Harness and Vacuum Piping

1. Install the engine harness and vacuum piping as an assembly.

Tightening torque:

19—25 N·m (1.9—2.6 m·kg, 14—19 ft·lb)

2. Connect the heat gauge unit connector and ground.
3. Connect the evaporative hoses to the intermediate housing and oil filler pipe.

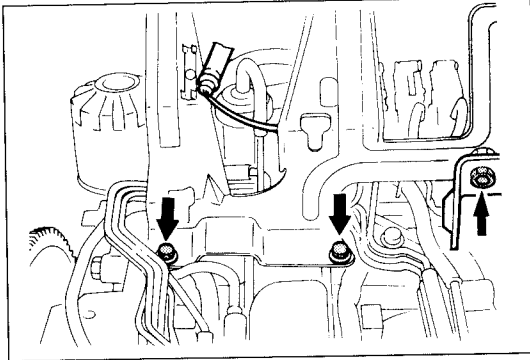

97U0CX-148

Dynamic Chamber Bracket

1. Install the dynamic chamber bracket.

Tightening torque:

19—25 N·m (1.9—2.6 m·kg, 14—19 ft·lb)

2. Connect the knock sensor connector and mount it to the bracket.

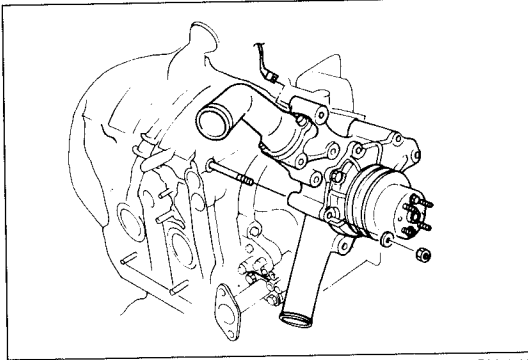

97U0CX-149

Water Pump

1. Install the water pump and a new gasket.

Tightening torque:

18—26 N·m (1.8—2.7 m·kg, 13—20 ft·lb)

Caution

Do not forget to use shims on the studs where the gasket does not mount.

2. Connect the couplers of the water thermosensor and water thermostwitch.

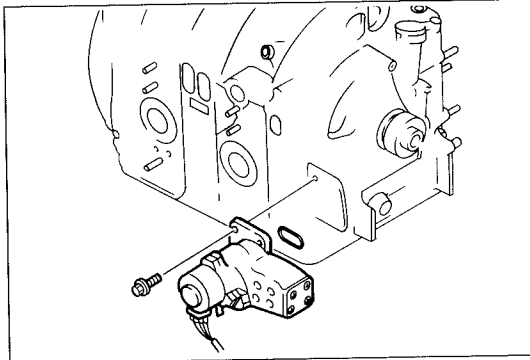

97U0CX-150

Metering Oil Pump

1. Apply engine oil to the new O-ring.
2. Install the metering oil pump to the front housing.

Tightening torque:

7.8—11 N·m (80—110 cm·kg, 69—95 in·lb)

3. Connect the metering oil pump connectors.

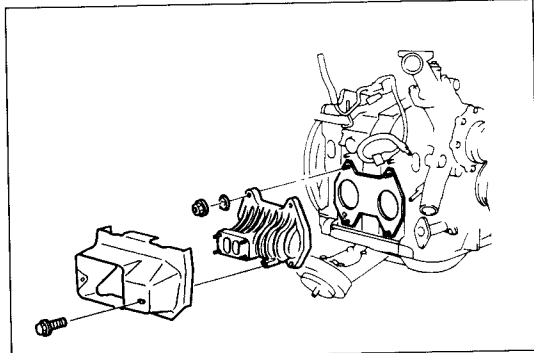

97U0CX-151

Exhaust Manifold and Insulator

1. Install the new exhaust manifold gasket so that the hole is positioned on the rear rotor housing.
2. Install the exhaust manifold.

Tightening torque:

31—46 N·m (3.2—4.7 m·kg, 23—34 ft·lb)

3. Install the exhaust manifold insulator.

Tightening torque:

7.8—11 N·m (80—110 cm·kg, 69—95 in·lb)

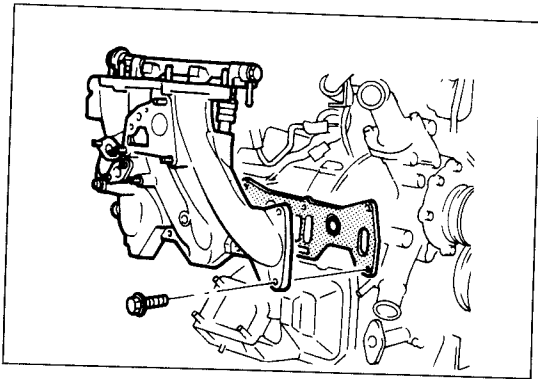

77U01X-022

Intake Manifold

1. Install the new intake manifold gasket and new O-rings on the engine.
2. Install the intake manifold.

Tightening torque:

19—25 N·m (1.9—2.6 m·kg, 14—19 ft·lb)

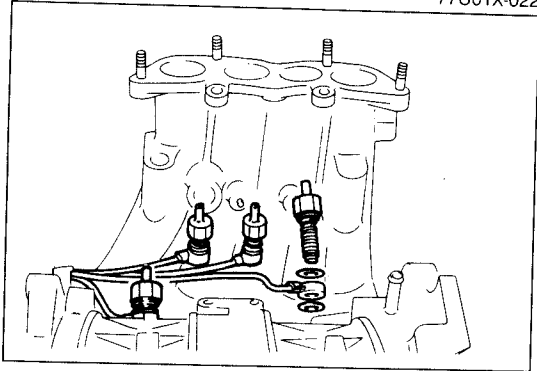

77U01X-023

Housing Oil Nozzle and Manifold Oil Nozzle

Install the oil nozzles and connect the metering oil tubes with new washers.

Tightening torque:

16—23 N·m (1.6—2.3 m·kg, 12—17 ft·lb)

Note

The oil tube ends are colored.

White..... for front rotor housing

Yellow for rear rotor housing

Blue for front inlet port

Green for rear inlet port

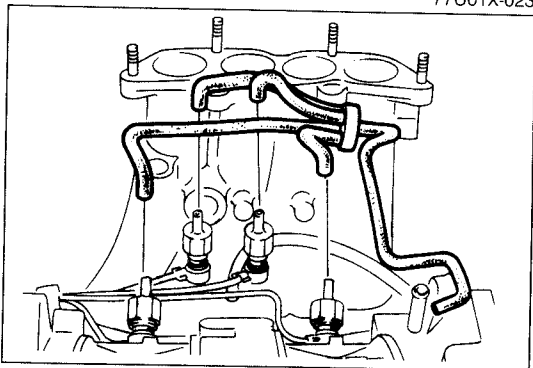

97U0CX-152

Air Tube

Install the air tube assembly and connect the tubes to the oil nozzles.

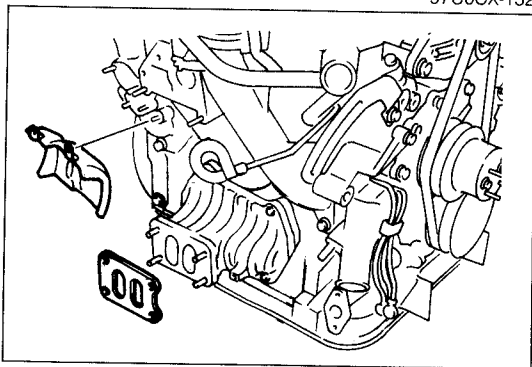

77U01X-024

Turbocharger and Insulator

1. Install the new gasket and the insulator.

2. Install the turbocharger.

Tightening torque:

44—54 N·m (4.5—5.5 m·kg, 33—40 ft·lb)

3. Connect the water hoses, and the oil pipes and new gaskets.

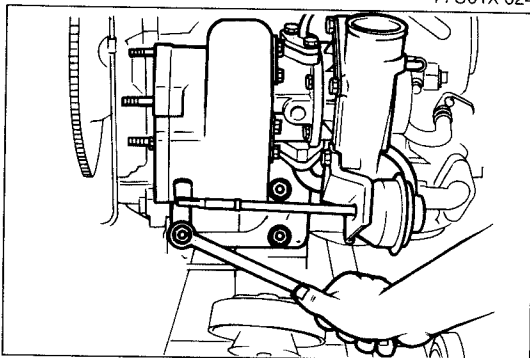

97U0CX-153

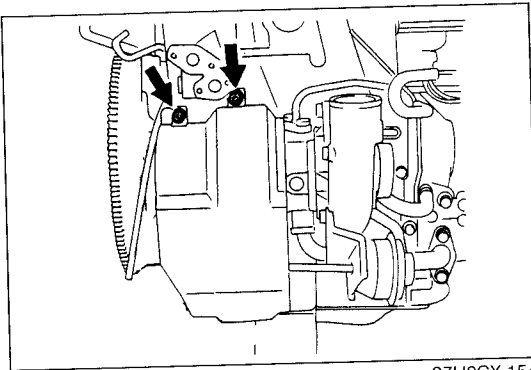

97U0CX-154

4. Install the insulator.

Tightening torque:
7.8—11 N·m (80—110 cm·kg, 69—95 in·lb)

5. Install the water pipe and the new gasket and new washers.

Tightening torque:
24—35 N·m (2.4—3.6 m·kg, 17—26 ft·lb)

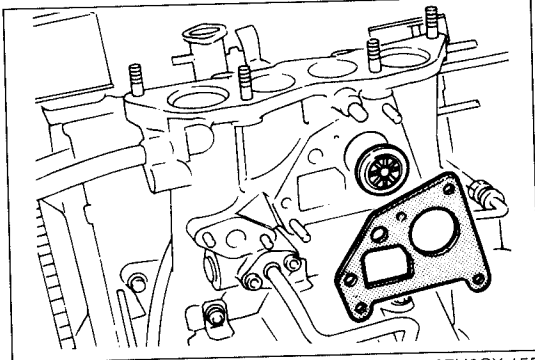

97U0CX-155

Air Control Valve (ACV)

1. Install the check valve and the new gasket.

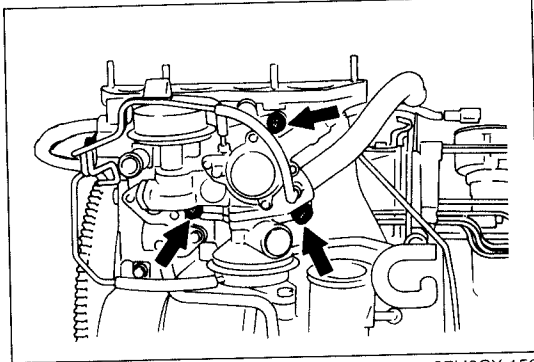

97U0CX-156

2. Install the air control valve so that the check valve does not fall from the intake manifold.
3. Connect the couplers of the split air solenoid valve and the port air solenoid valve.

Tightening torque:
7.8—11 N·m (80—110 cm·kg, 69—95 in·lb)

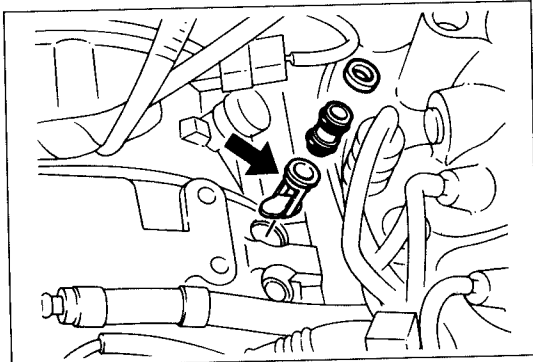

97U0CX-157

Primary Fuel Injectors and Distribution Pipe

1. Apply engine oil to the O-ring of the air bleed socket.
2. Insert the mixing plate into the intermediate housing with plate's tab faced upward.
3. Insert the air bleed socket and injector insulator into the intermediate housing.

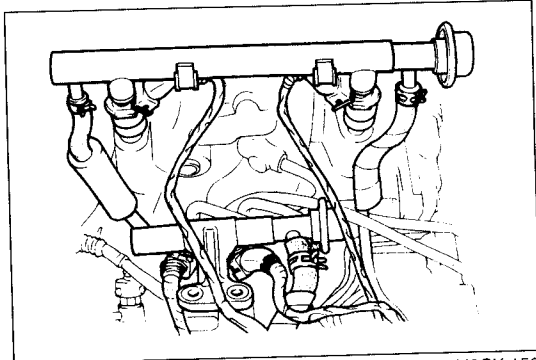

97U0CX-158

4. Apply engine oil to the injector O-rings, and install the primary fuel injectors.
5. Install the fuel distribution pipe and the insulator.

Tightening torque:
19—25 N·m (1.9—2.6 m·kg, 14—19 ft·lb)

6. Connect the fuel hoses.
7. Connect the injector couplers.

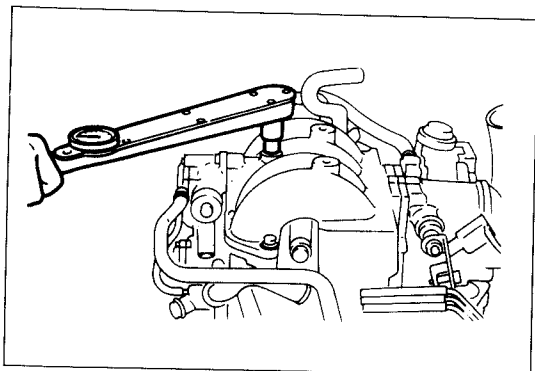

97U0CX-159

Throttle and Dynamic Chamber

1. Install the throttle and dynamic chamber assembly and the new gasket.

Tightening torque:

19—25 N·m (1.9—2.6 m·kg, 14—19 ft·lb)

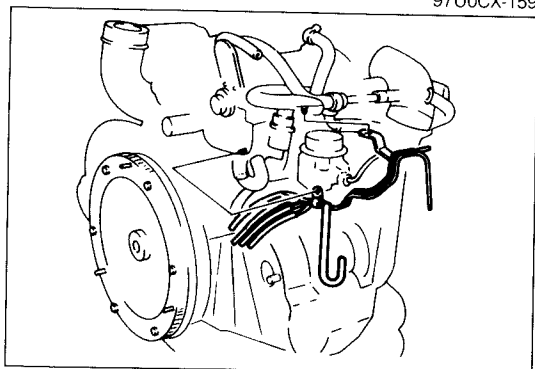

97U0CX-216

2. Install the second vacuum piping on the intake manifold.

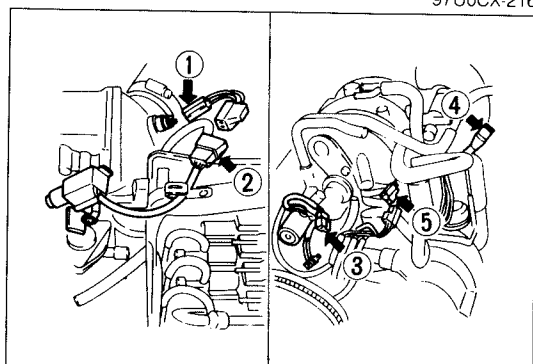

97U0CX-160

3. Connect the vacuum hoses and water hoses.

4. Connect the following connectors:

- (1) Intake air temperature sensor
- (2) Throttle sensor
- (3) Air supply solenoid valve
- (4) Bypass air control valve
- (5) Air bypass solenoid valve

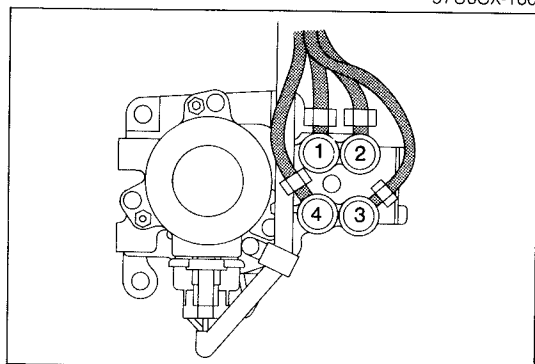

97U0CX-161

Metering Oil Tube

Connect the oil tubes so that the colors of the tube ends match the numbers as shown.

- | | |
|---------------|----------------|
| 1 White | 2 Blue |
| 3 Green | 4 Yellow |

Tightening torque:

9.8—14 N·m (100—140 cm·kg, 87—122 in·lb)

STEP 2 Torque Specifications

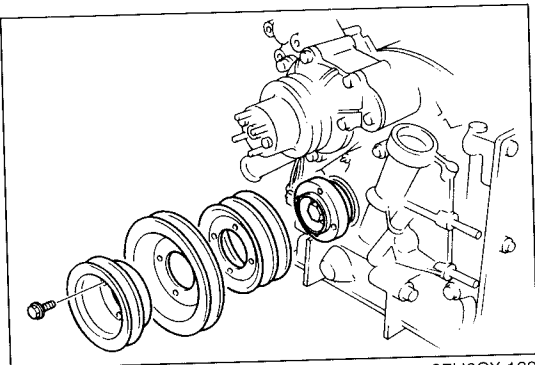
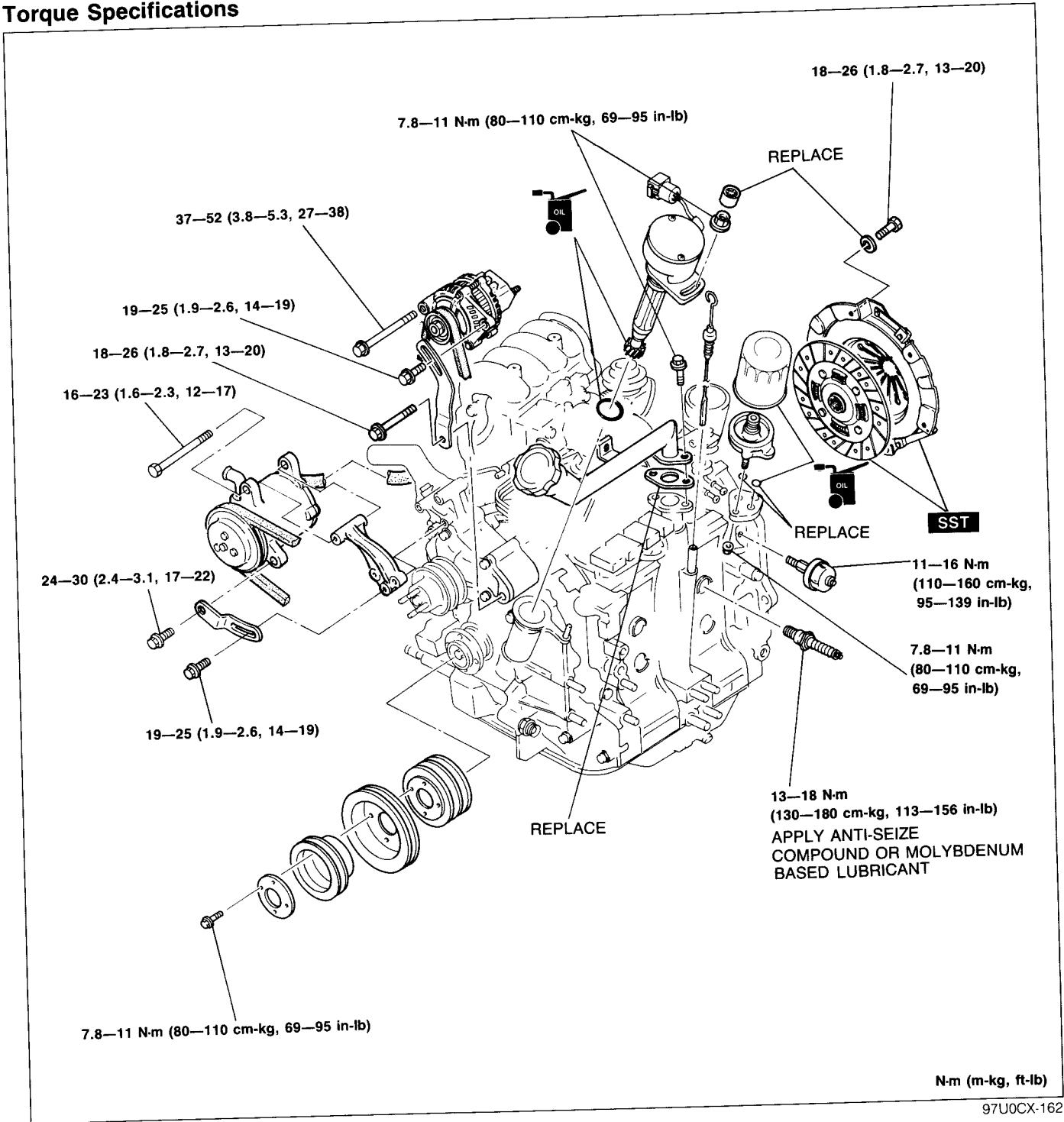

Eccentric Shaft Pulley

Install the eccentric shaft pulleys and stiffener to the pulley boss.

Tightening torque:

7.8—11 N·m (80—110 cm·kg, 69—95 in·lb)

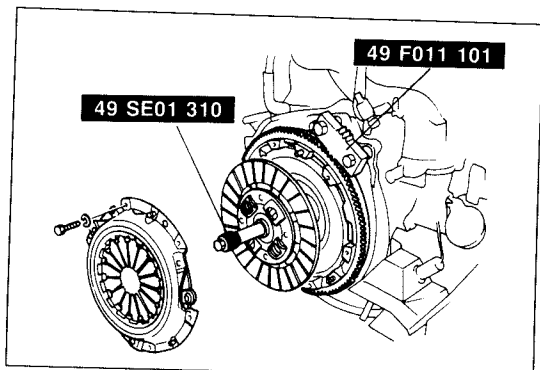

97U0CX-164

Clutch Disc and Clutch Cover

Install the clutch disc and clutch cover with the **SST**.

Tightening torque:

18—26 N·m (1.8—2.7 m·kg, 13—20 ft·lb)

Caution

Place a rag between the SST and the vacuum pipes to protect the pipes.

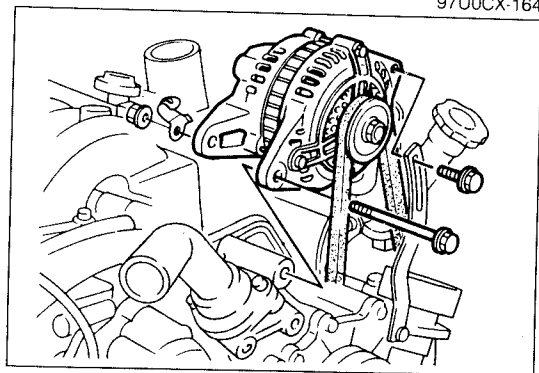

97U0CX-165

Alternator

Install the alternator strap, alternator and drive belt.

Tightening torque:

Alternator long bolt:

37—52 N·m (3.8—5.3 m·kg, 27—38 ft·lb)

Alternator short bolt:

19—25 N·m (1.9—2.6 m·kg, 14—19 ft·lb)

Strap: 18—26 N·m (1.8—2.7 m·kg, 13—20 ft·lb)

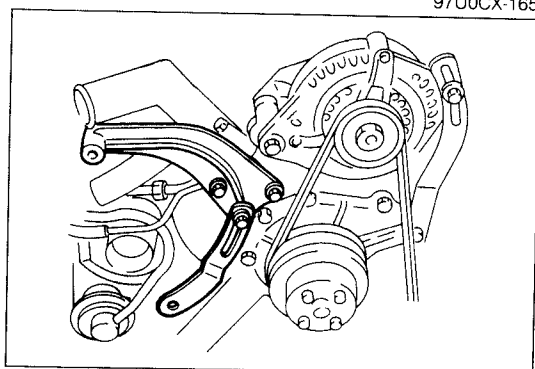

67U01X-210

Air Pump

1. Install the air pump bracket and strap to the water pump.

Tightening torque:

19—25 N·m (1.9—2.6 m·kg, 14—19 ft·lb)

2. Install the air pump.

Tightening torque:

Long bolt:

16—23 N·m (1.6—2.3 m·kg, 12—17 ft·lb)

Short bolt:

24—30 N·m (2.4—3.1 m·kg, 17—22 ft·lb)

3. Connect the air hose to the air control valve.

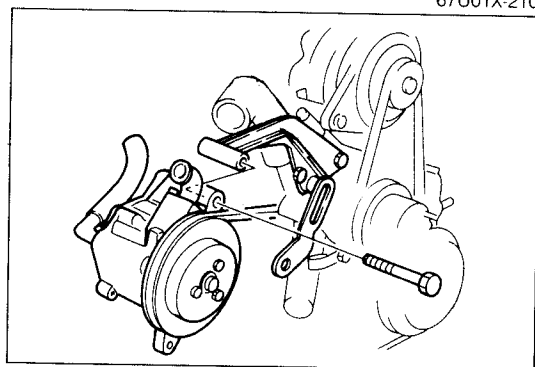

67U01X-211

Crank Angle Sensor

1. Turn the eccentric shaft until the leading top mark (Yellow) is aligned with the indicator pin.

2. Apply engine oil to the new O-ring, and install it on the crank angle sensor.

3. Apply engine oil to the drive gear.

4. Match the matching mark and install the crank angle sensor on the front cover.

Tightening torque:

7.8—11 N·m (80—110 cm·kg, 69—95 in·lb)

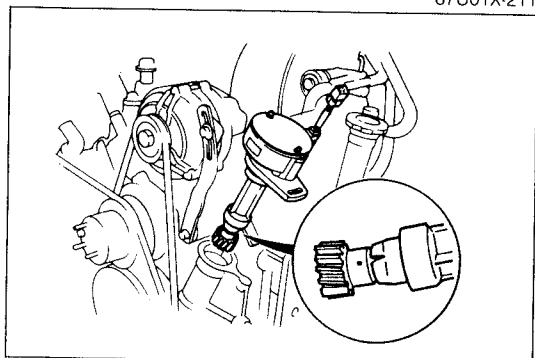

97U0CX-166

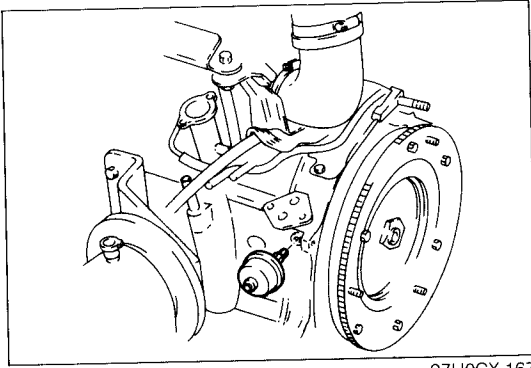

97U0CX-167

Oil Pressure Gauge

Install the oil pressure gauge in the rear housing.

Tightening torque:

11—16 N·m (110—160 cm·kg, 95—139 in·lb)

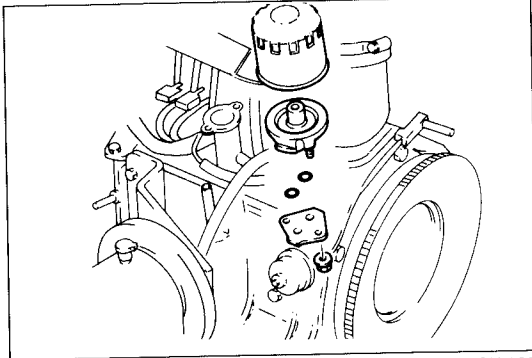

97U0CX-168

Oil Filter

1. Install the oil filter body together with the new O-rings.

Tightening torque:

7.8—11 N·m (80—110 cm·kg, 69—95 in·lb)

2. Apply engine oil to the rubber seal of the oil filter.
3. Install the oil filter until the rubber seal contacts the base, and then tighten the filter an additional 1—1/6 turn with a wrench.

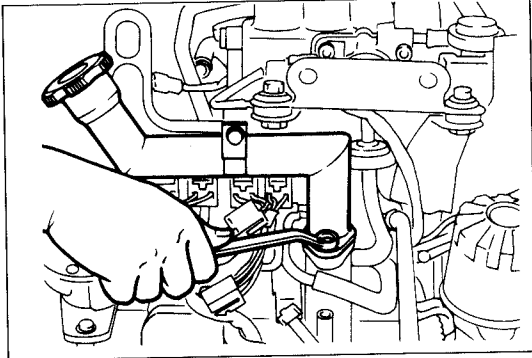

97U0CX-169

Oil Filler Pipe

Install the oil filler pipe with a new gasket.

Oil Level Gauge

Install the oil level gauge.

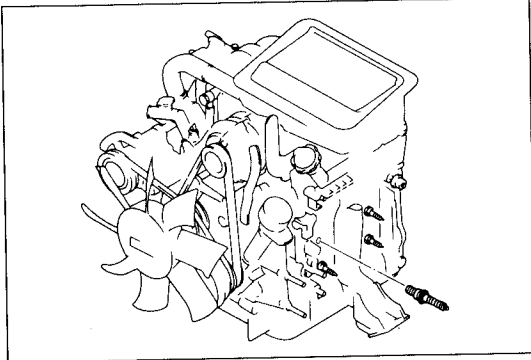

97U0CX-170

Spark Plug

1. Remove the engine from the **engine hanger** and **engine stand**.
2. Apply anti-seize compound or molybdenum-based lubricant to the spark plug threads.
3. Install the spark plugs.

Tightening torque:

13—18 N·m (130—180 cm·kg, 113—156 in·lb)

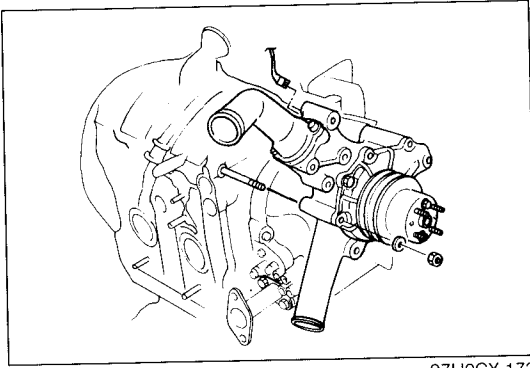

97U0CX-173

Water Pump

1. Install the water pump and a new gasket.

Tightening torque:

18—26 N·m (1.8—2.7 m·kg, 13—20 ft·lb)

Caution

Do not forget to use shims on the studs where the gasket does not mount.

2. Connect the couplers of the water thermosensor and water thermostwitch.

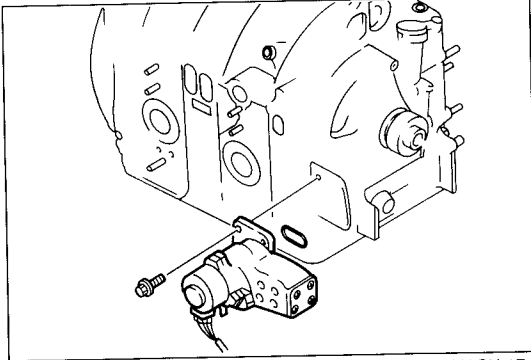

97U0CX-174

Metering Oil Pump

1. Apply engine oil to the new O-ring.
2. Install the metering oil pump onto the front housing.

Tightening torque:

7.8—11 N·m (80—110 cm·kg, 69—95 in·lb)

3. Connect the metering oil pump connector.

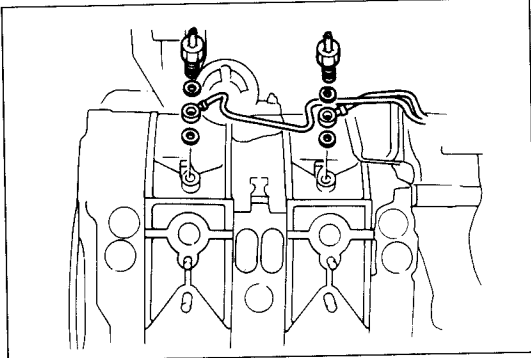

97U0CX-175

Housing Oil Nozzle and Metering Oil Tube

Install the housing oil nozzle and the oil tube and new washers to the front and rear rotor housing.

Tightening torque:

16—23 N·m (1.6—2.3 m·kg, 12—17 ft·lb)

Note

**The oil tube ends are colored.
For front housing.....White
For rear housing.....Yellow**

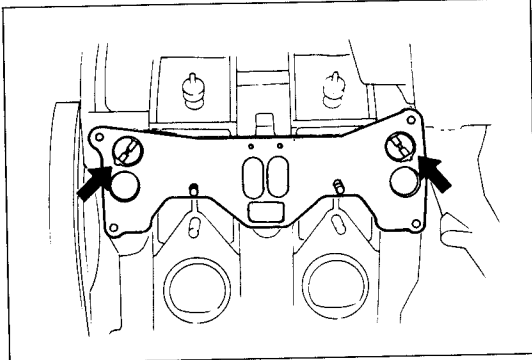

67U01X-198

Intake Manifold

1. Install the new intake manifold gasket on the engine.
2. Install the auxiliary port valves so that the bigger side of the pin is aligned to the matching mark.

3. Install the intake manifold.

Tightening torque:

19—25 N·m (1.9—2.6 m·kg, 14—19 ft·lb)

4. Connect the couplers of the split air solenoid valve and port air solenoid valve.
5. Connect the vacuum pipes.

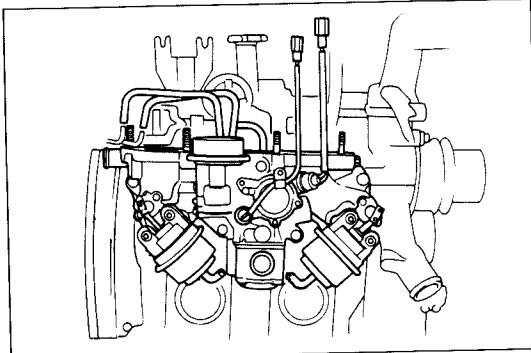

97U0CX-176

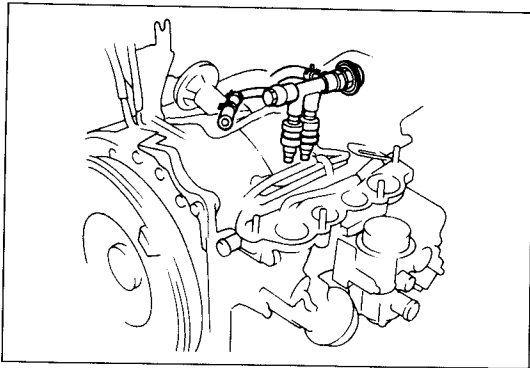

97U0CX-217

Fuel Injector and Delivery Pipe

1. Insert the air bleed socket and rubber insert to the injector holes.
2. Apply engine oil to the injector O-rings, and install the fuel injectors.
3. Install the fuel delivery pipe.

Tightening torque:

19—25 N·m (1.9—2.6 m·kg, 14—19 ft·lb)

4. Tighten the vacuum piping mounting bolts.

Tightening torque:

19—25 N·m (1.9—2.6 m·kg, 14—19 ft·lb)

Manifold Oil Nozzle and Metering Oil Tube

Install the manifold oil nozzle and the oil tube and new washers to the intake manifold.

Note

The oil tube ends are colored.

For front port.....Blue

For rear port.....Green

Tightening torque:

16—23 N·m (1.6—2.3 m·kg, 12—17 ft·lb)

Air Tube

Connect the hoses to the oil nozzles.

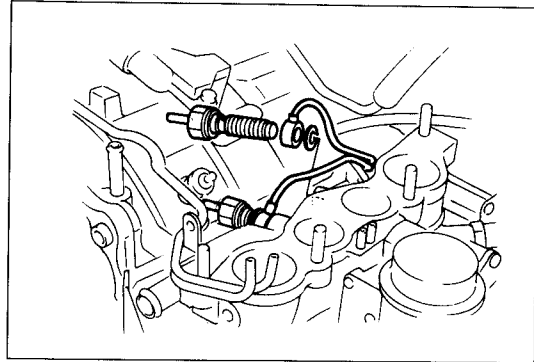

97U0CX-177

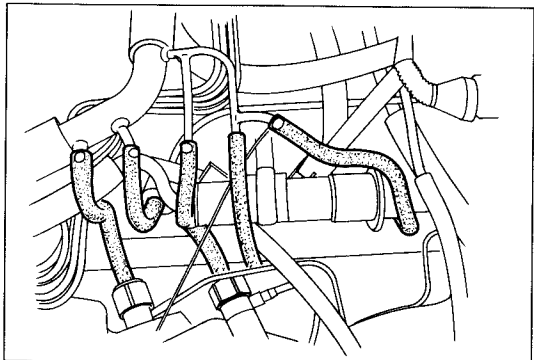

97U0CX-178

Exhaust Manifold and Insulator

1. Install the exhaust manifold and insulator and a new gasket.

Tightening torque:

31—46 N·m (3.2—4.7 m·kg, 23—34 ft·lb)

2. Install the absorber plate.

Tightening torque:

7.8—11 N·m (80—110 cm·kg, 69—95 in·lb)

3. Connect the coupler to the oxygen sensor.

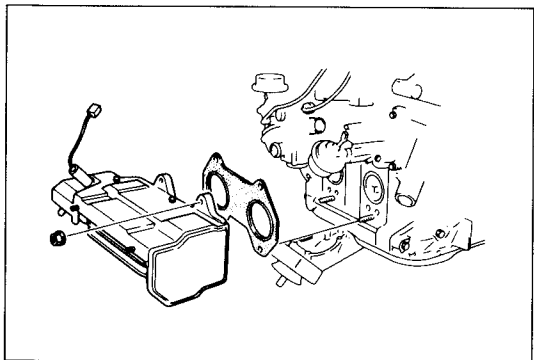

97U0CX-179

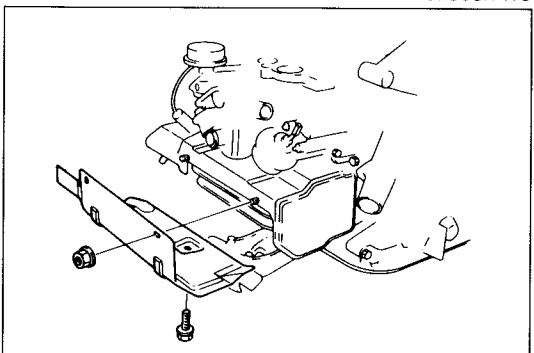

97U0CX-180

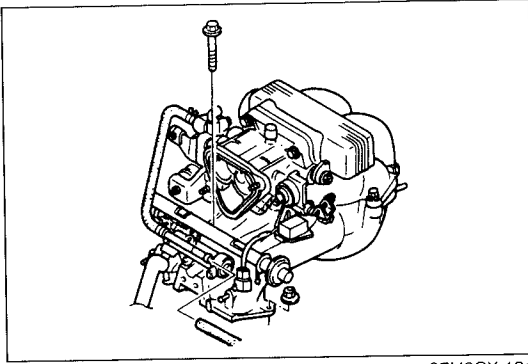

97U0CX-181

Throttle and Dynamic Chamber

1. Install the throttle and dynamic chamber assembly and a new gasket.

Tightening torque:**19—25 N·m (1.9—2.6 m·kg, 14—19 ft·lb)**

2. Connect the vacuum hoses, water hoses, and fuel hose.
3. Connect the couplers of the secondary injectors, throttle sensor, air bypass solenoid valve, bypass air control valve, and intake air temperature sensor.

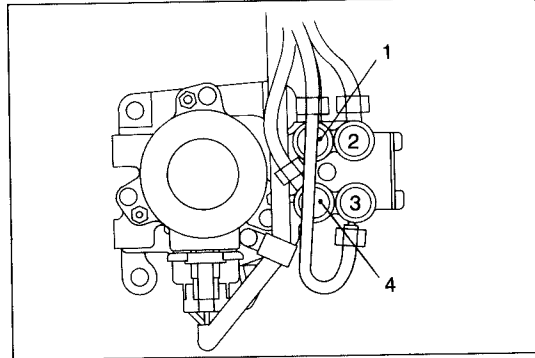

97U0CX-182

Metering Oil Tube

Connect the oil tubes so that the colors of the tube ends match the numbers as shown.

1	White	2	Blue
3	Green	4	Yellow

Tightening torque:**9.8—14 N·m (100—140 cm·kg, 87—122 in·lb)**

C ASSEMBLY (NON-TURBO)

STEP 2 Torque Specifications

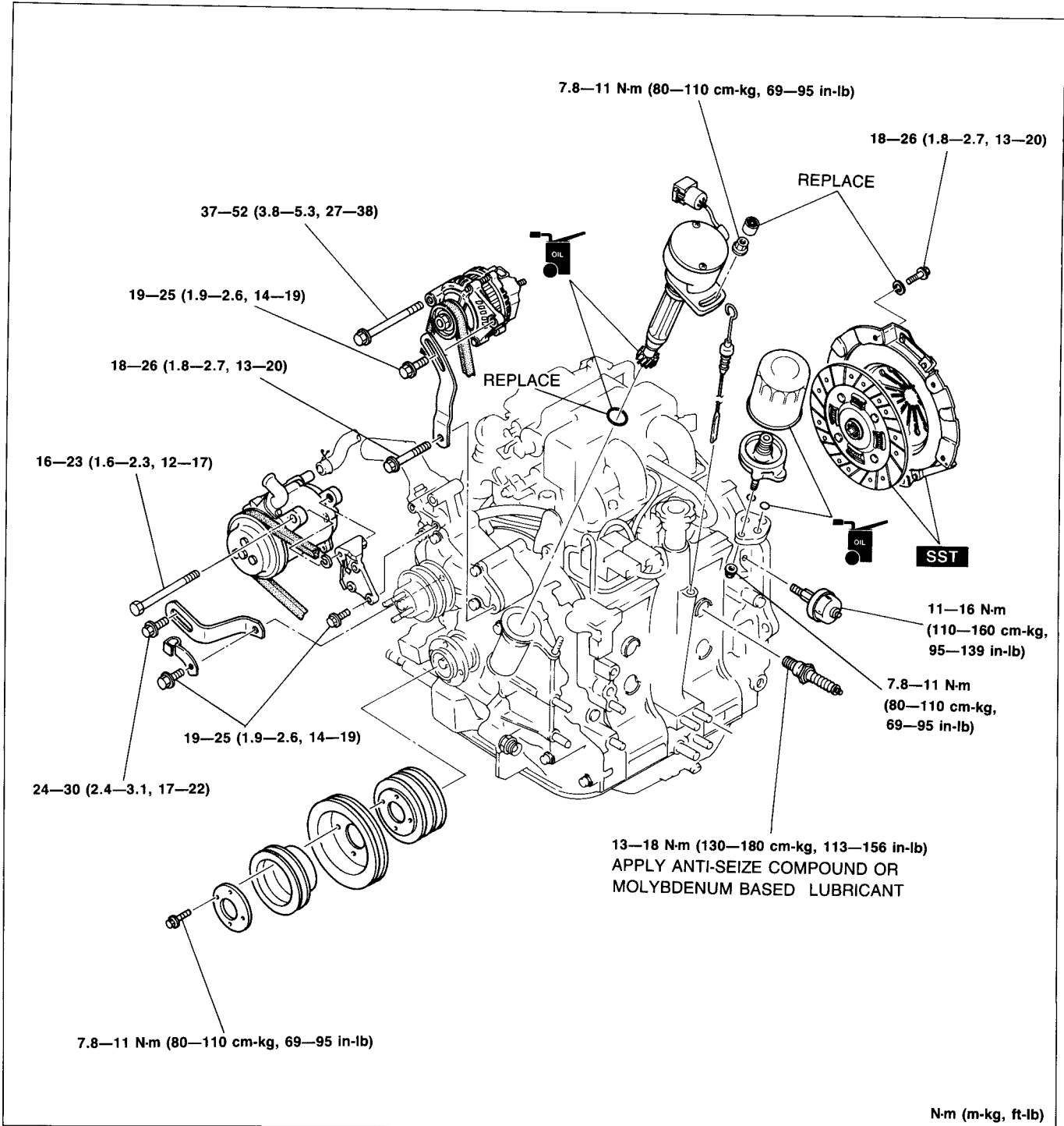

97U0CX-183

Eccentric Shaft Pulley

Install the eccentric shaft pulleys and stiffener to the pulley boss.

Tightening torque:

7.8—11 N·m (80—110 cm·kg, 69—95 in·lb)

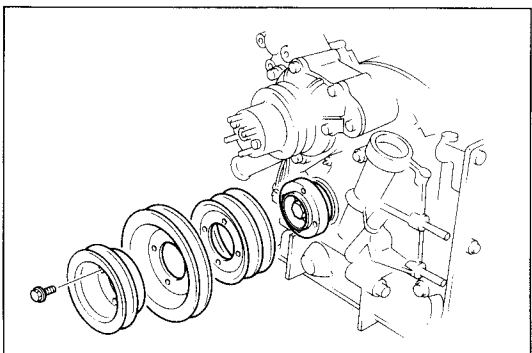

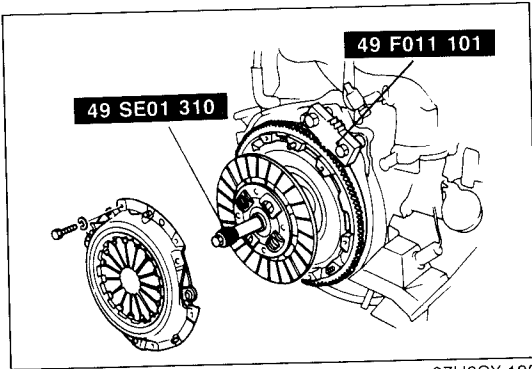

97U0CX-185

Clutch Disc and Clutch Cover

Install the clutch disc and clutch cover with the SST.

Tightening torque:

18—26 N·m (1.8—2.7 m·kg, 13—20 ft·lb)

Caution

Place a rag between the SST and the vacuum pipes to protect pipes.

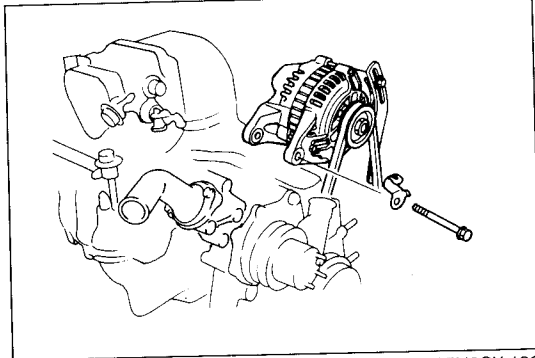

97U0CX-186

Alternator

Install the alternator strap, alternator, and drive belt.

Tightening torque:

Alternator long bolt:

37—52 N·m (3.8—5.3 m·kg, 27—38 ft·lb)

Alternator short bolt:

19—25 N·m (1.9—2.6 m·kg, 14—19 ft·lb)

Strap: 18—26 N·m (1.8—2.7 m·kg, 13—20 ft·lb)

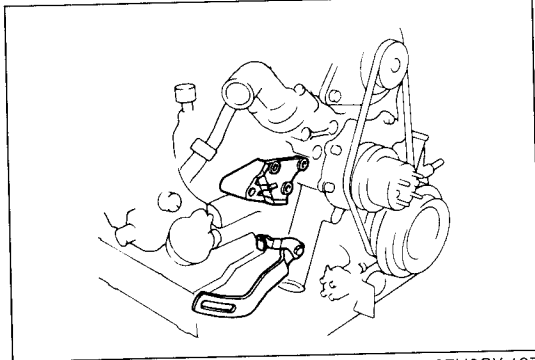

97U0CX-187

Air Pump

1. Mount the air pump bracket and strap to the water pump.

Tightening torque:

19—25 N·m (1.9—2.6 m·kg, 14—19 ft·lb)

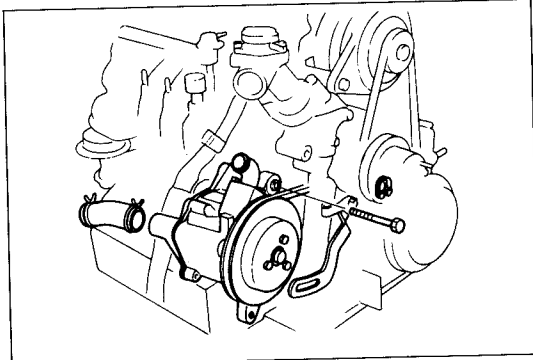

67U01X-211

2. Install the air pump.

Tightening torque:

Long bolt:

16—23 N·m (1.6—2.3 m·kg, 12—17 ft·lb)

Short bolt:

24—30 N·m (2.4—3.1 m·kg, 17—22 ft·lb)

3. Connect the air hose to the air control valve.

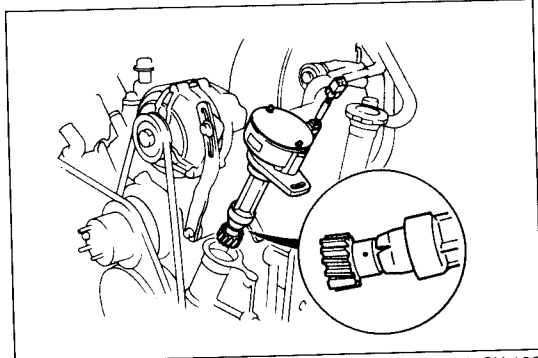

97U0CX-188

Crank Angle Sensor

1. Turn the eccentric shaft until the leading top mark (Yellow) is aligned with the indicator pin.
2. Apply engine oil to the new O-ring, and install it on the crank angle sensor.
3. Apply engine oil to the drive gear.
4. Align the marks, and install the crank angle sensor on the front cover.

Tightening torque:

7.8—11 N·m (80—110 cm·kg, 69—95 in·lb)

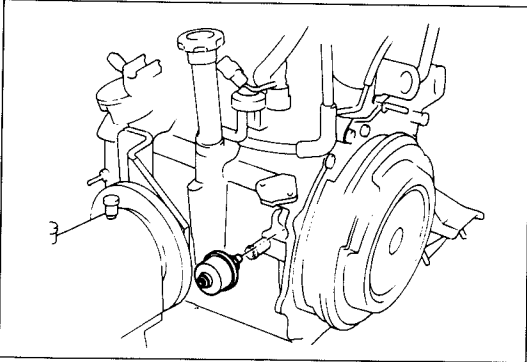

97U0CX-189

Oil Pressure Gauge

Install the oil pressure gauge in the rear housing.

Tightening torque:

11—16 N·m (110—160 cm·kg, 95—139 in·lb)

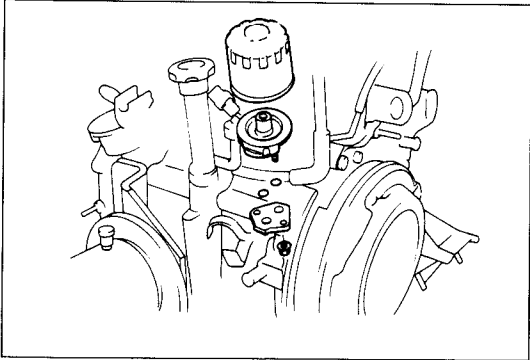

97U0CX-190

Oil Filter

1. Install the oil filter body together with the new O-rings.

Tightening torque:

7.8—11 N·m (80—110 cm·kg, 69—95 in·lb)

2. Apply engine oil to the rubber seal of the oil filter.
3. Install the oil filter until the rubber seal contacts the base, and then tighten the filter an additional 1—1/6 turn with a wrench.

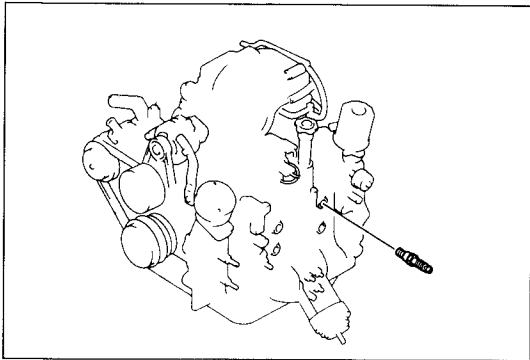

97U0CX-191

Spark Plug

1. Remove the engine from the **engine hanger** and **engine stand**.
2. Apply anti-seize compound or molybdenum-based lubricant to the spark plug threads.
3. Install the spark plugs.

Tightening torque:

13—18 N·m (130—180 cm·kg, 113—156 in·lb)

ENGINE STAND REMOVAL

REMOVAL

1. Remove the engine from the engine stand.
2. Remove the **SST** from the engine.

97U0CX-192

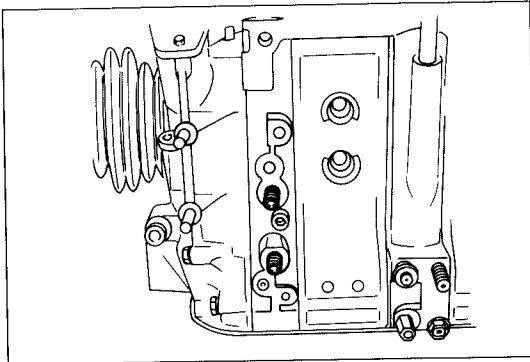

97U0CX-193

3. Install the new studs into the front housing.

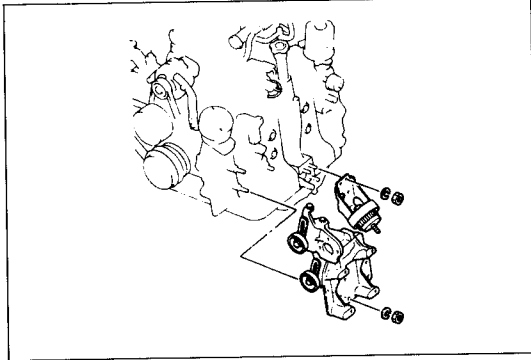

97U0CX-194

4. Install the left engine mount.

Tightening torque:

55—80 N·m (5.6—8.2 m·kg, 41—59 ft·lb)

5. Install the A/C compressor and P/S pump bracket.

Tightening torque:

M10: 31—46 N·m (3.2—4.7 m·kg, 23—34 ft·lb)

M12: 55—80 N·m (5.6—8.2 m·kg, 41—59 ft·lb)

C INSTALLATION (TURBO)

INSTALLATION

INSTALLATION (TURBO) PREPARATION SST

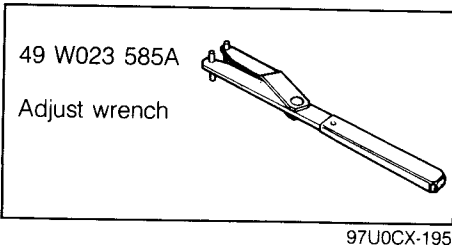

Warning: Be sure the vehicle is securely supported.

1. Install in the reverse order of removal referring to the **Installation Note**.
2. Tighten all bolts and nuts to the specified torque.

Note

- a) Position the hose clamp in the original location on the hose.
- b) Squeeze the clamp lightly with large pliers to ensure a good fit.

STEP 1

Torque Specifications

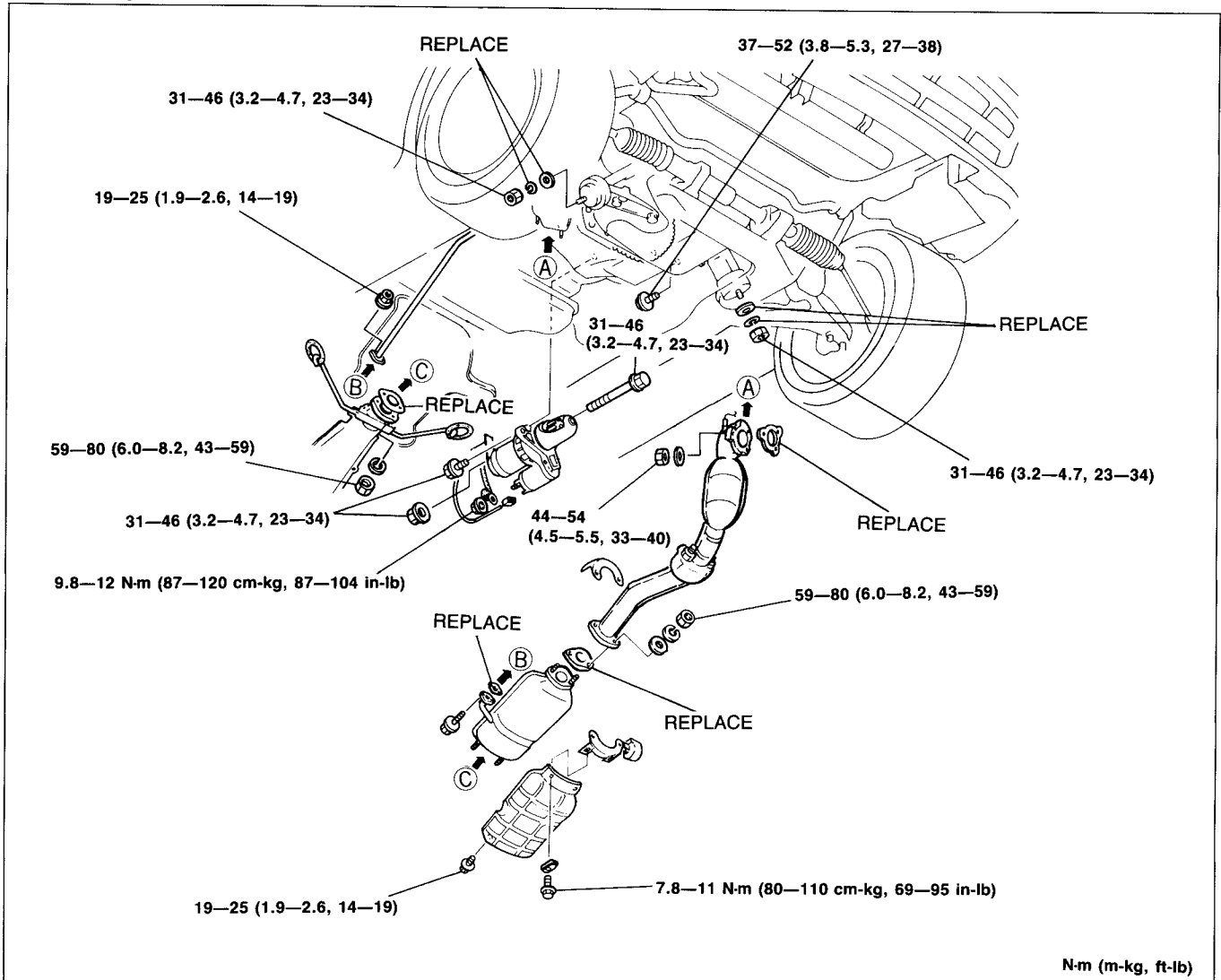

STEP 2 Torque Specifications

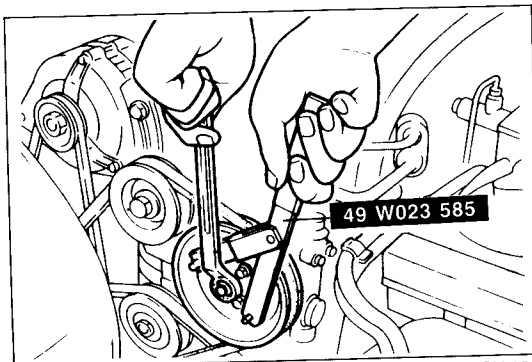
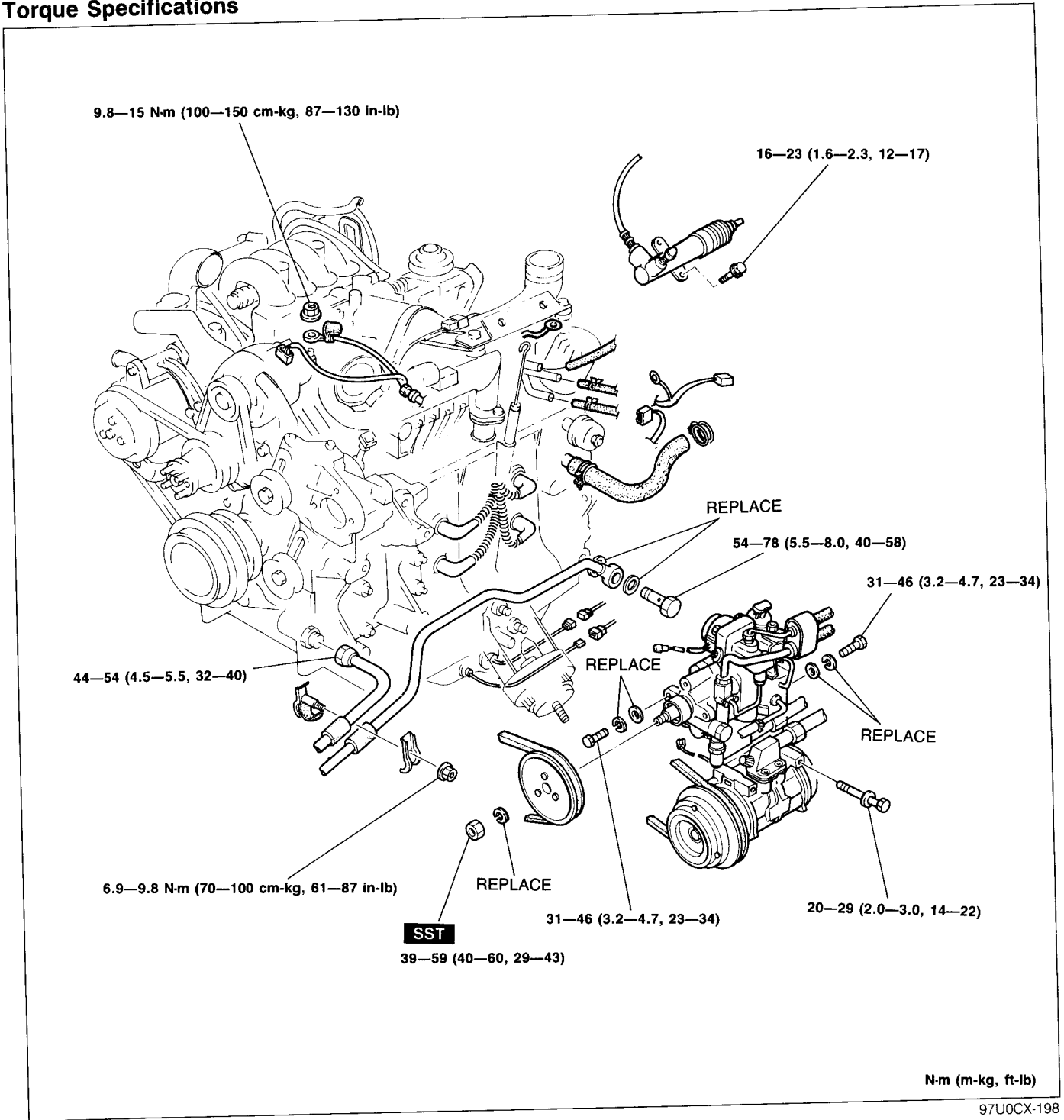

97U0CX-199

Installation Note P/S oil pump

1. Install the P/S oil pump.

Tightening torque:

31—46 N·m (3.2—4.7 m·kg, 23—34 ft·lb)

2. Install the P/S oil pump pulley using the **SST**.

Tightening torque:

39—49 N·m (4.0—5.0 m·kg, 29—36 ft·lb)

STEP 3 Torque Specifications

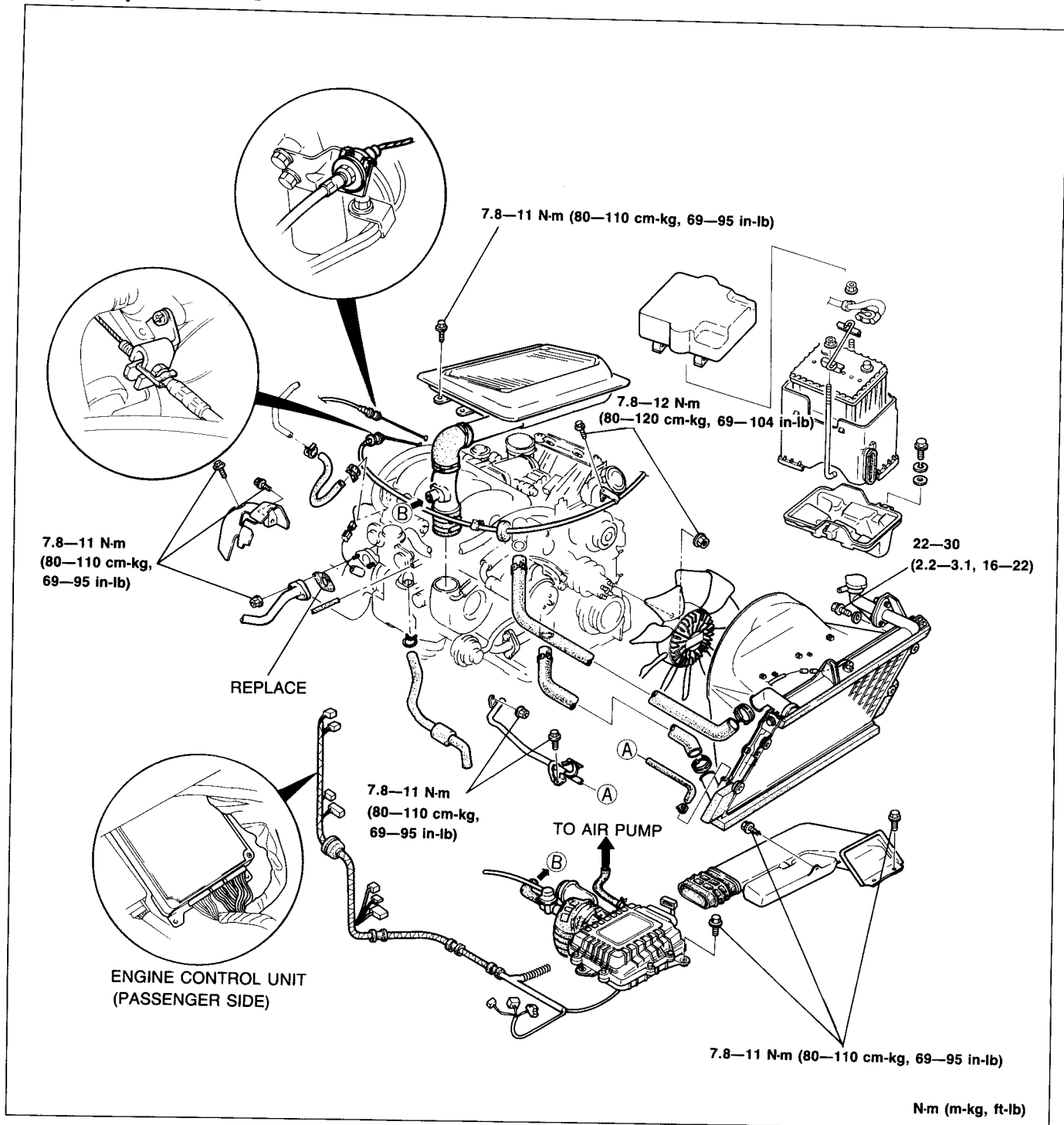

97U0CX-200

Installation Note

Water hose

Position the hose clamp in the original location on the hose. Squeeze the clamp lightly with large pliers to ensure a good fit.

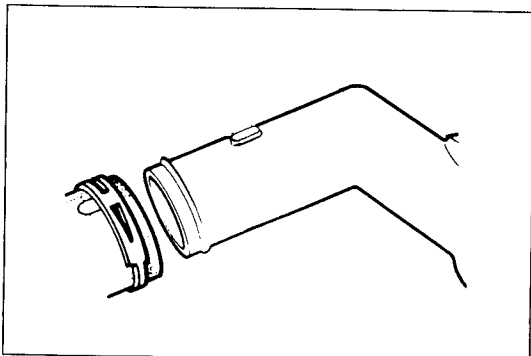

97U0CX-201

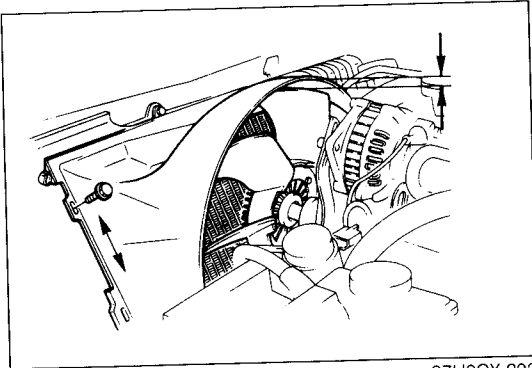

97U0CX-202

Cooling fan clearance

Check for cooling fan clearance. Move the radiator cowling and adjust the clearance if necessary.

Cooling fan clearance: 16—24mm (0.63—0.94 in)

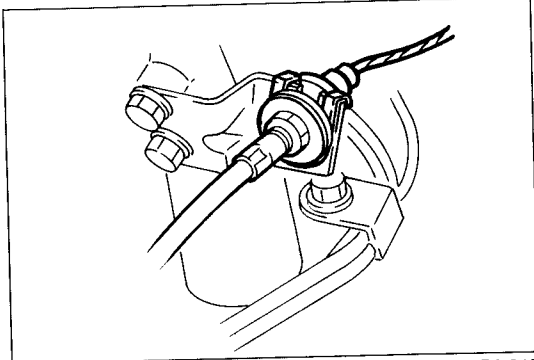

9MU0B2-246

Accelerator Cable

Install the accelerator cable.

Cable deflection: 1—3mm (0.039—0.118 in)

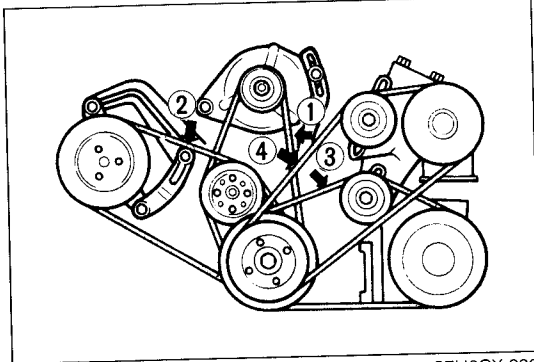

97U0CX-203

Drive Belt

Install and adjust the drive belt deflection. (Refer to page C-5.)

Engine Oil

Add the specified amount and type of engine oil. (Refer to Section D.)

Coolant

Close the drain plug; then fill the radiator and reservoir tank with the specified amount and type of coolant. (Refer to Section E.)

Check Engine Condition

1. Check for leaks.
2. Connect the negative battery cable.
3. Perform engine adjustments if necessary.
4. Perform a road test.
5. Recheck the oil and coolant levels.

97U0CX-204

C INSTALLATION (NON-TURBO)

INSTALLATION (NON-TURBO) PREPARATION SST

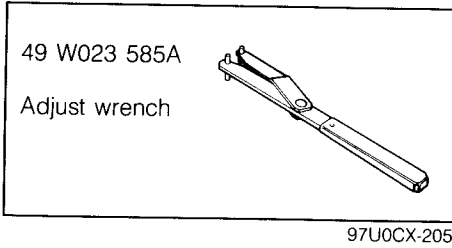

Warning: Be sure the vehicle is securely supported.

1. Install in the reverse order of removal referring to the **Installation Note**.
2. Tighten all bolts and nuts to the specified torque.

Note

- a) Position the hose clamp in the original location on the hose.
- b) Squeeze the clamp lightly with large pliers to ensure a good fit.

STEP 1

Torque Specifications

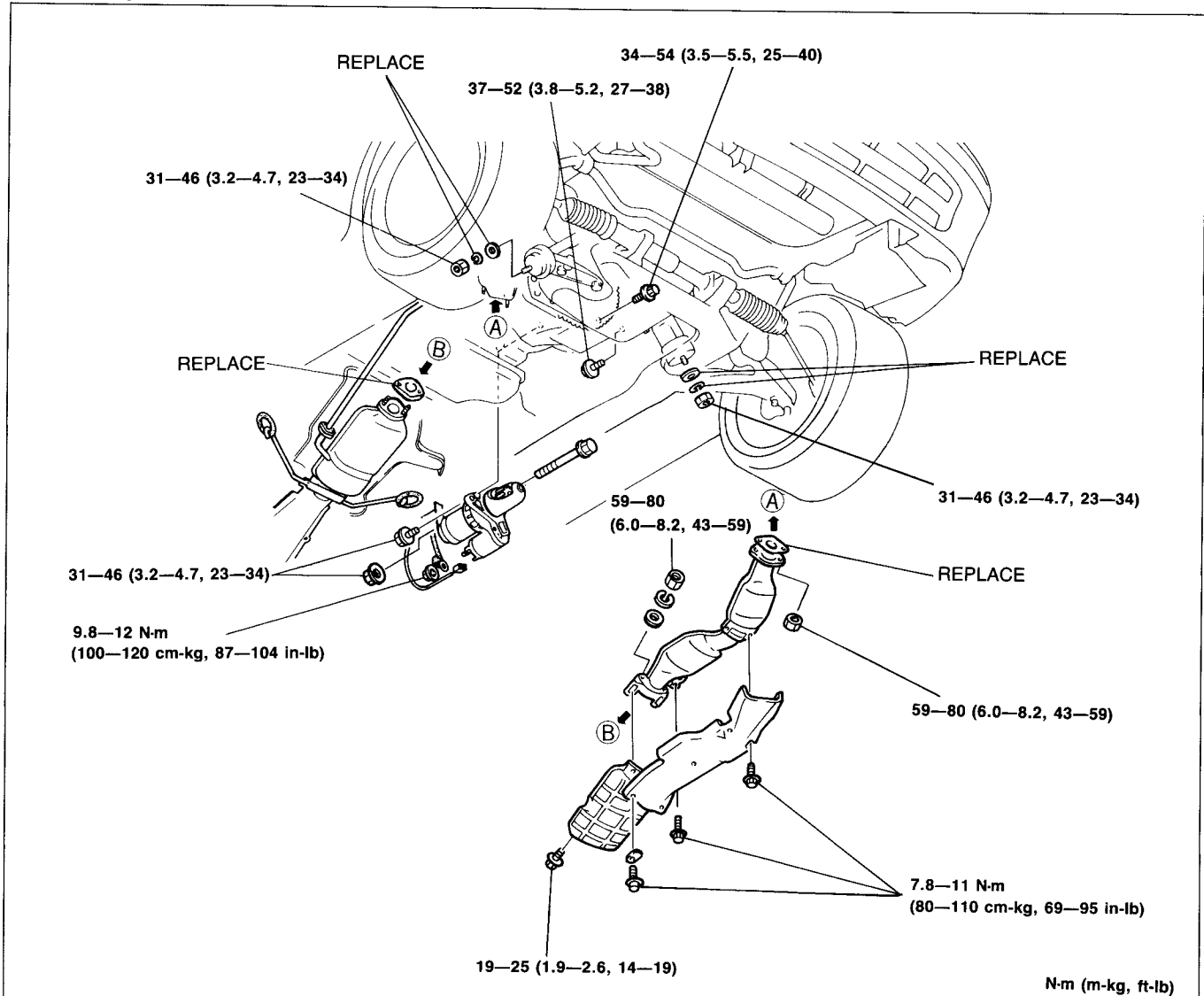

STEP 2
Torque Specifications

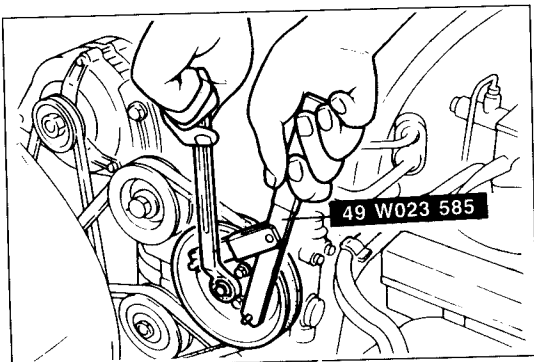
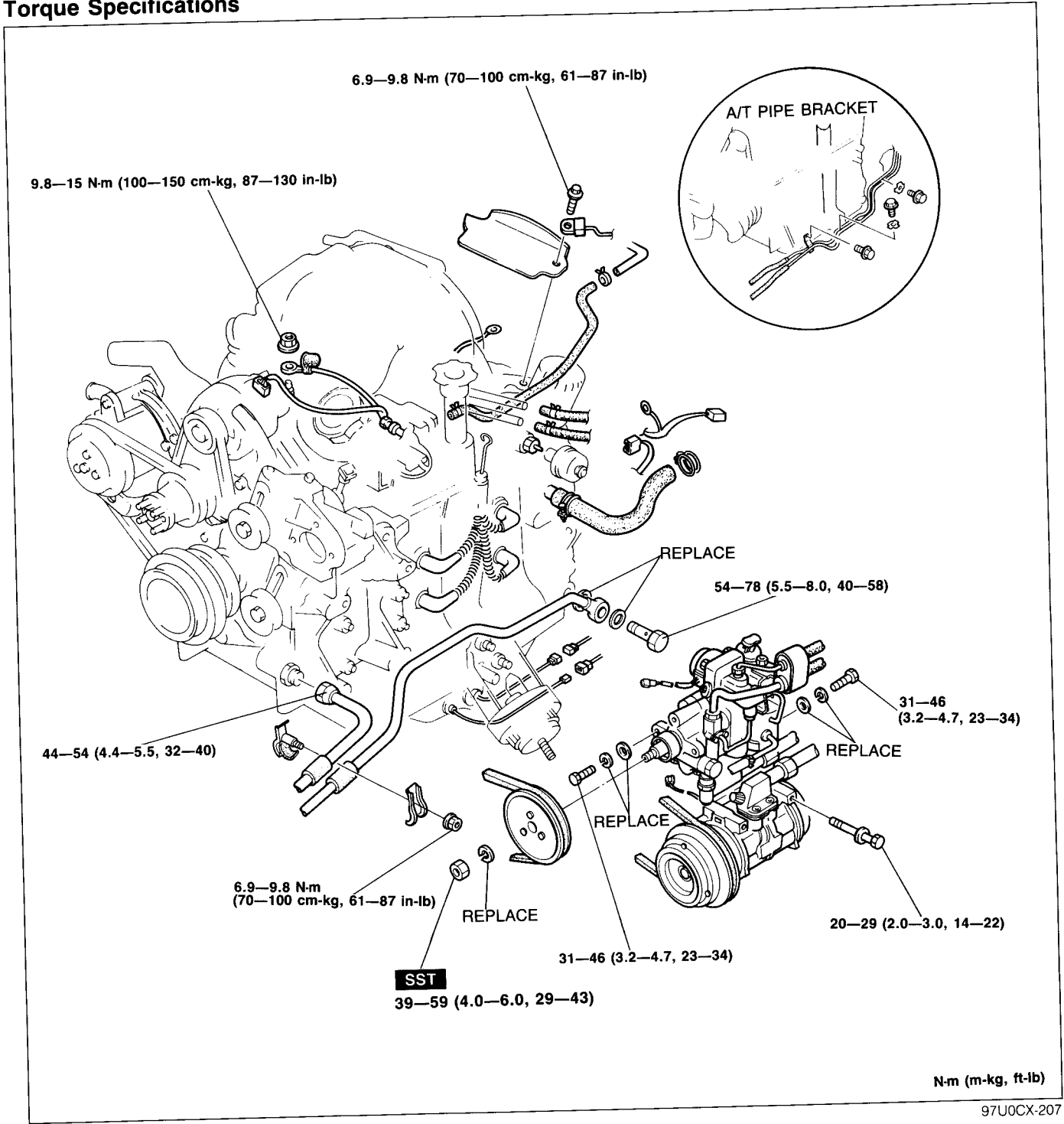

97U0CX-208

Installation Note

P/S oil pump

1. Install the P/S oil pump.

Tightening torque:

31—46 N-m (3.2—4.7 m-kg, 23—34 ft-lb)

2. Install the P/S oil pump pulley using the **SST**.

Tightening torque:

39—49 N-m (4.0—5.0 m-kg, 29—36 ft-lb)

STEP 3 Torque Specifications

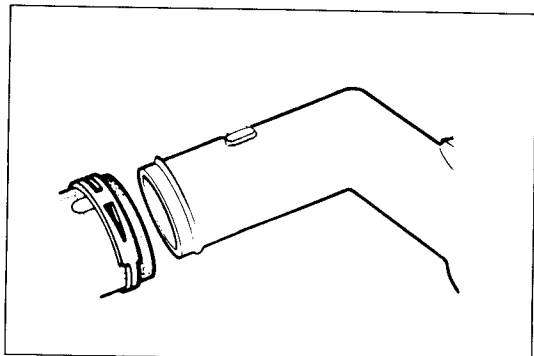
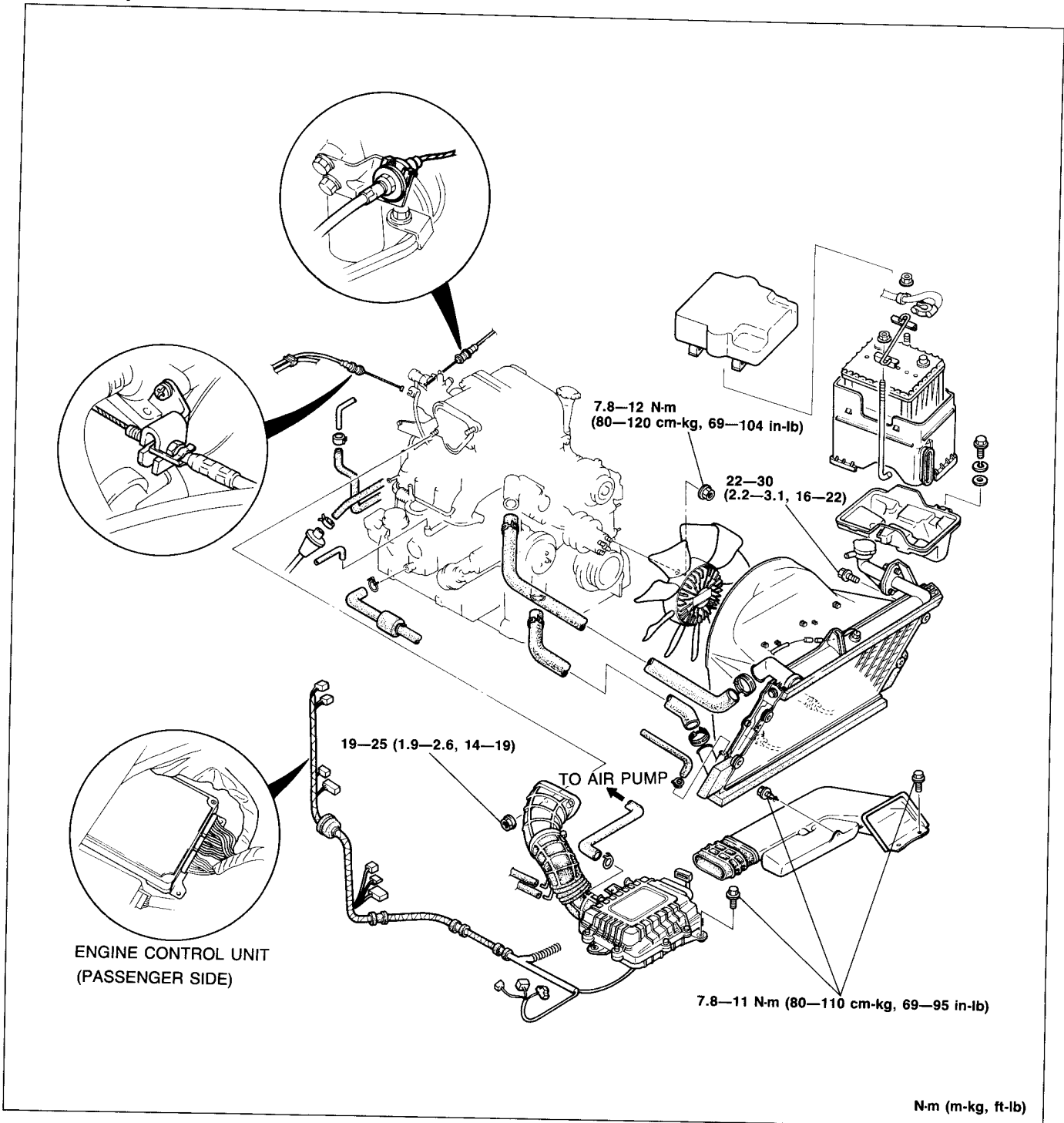

Installation Note Water hose

Position the hose clamp in the original location on the hose. Squeeze the clamp lightly with large pliers to ensure a good fit.

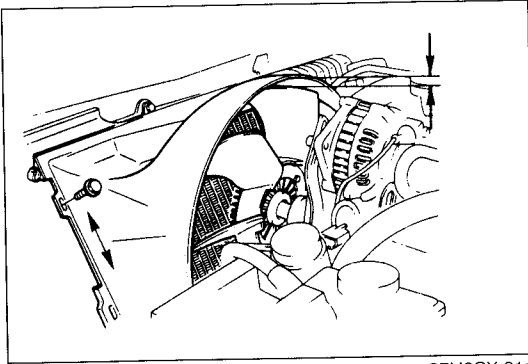

97U0CX-211

Cooling fan clearance

Check for cooling fan clearance. Move the radiator cowling and adjust the clearance if necessary.

Cooling fan clearance: 16—24mm (0.63—0.94 in)

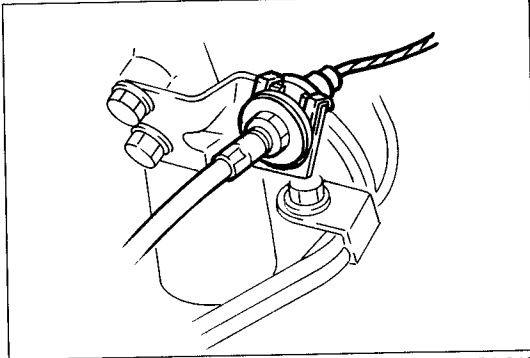

9MU0B2-246

Accelerator Cable

Install the accelerator cable.

Cable deflection: 1—3mm (0.039—0.118 in)

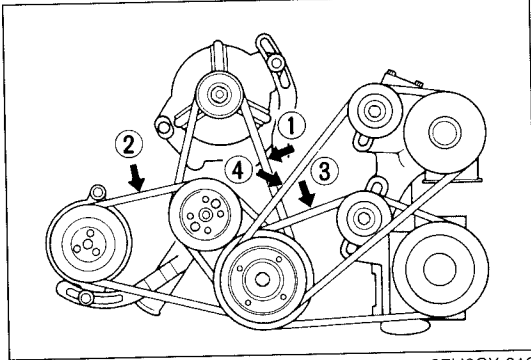

97U0CX-212

Drive Belt

Install and adjust the drive belt deflection.
(Refer to page C-5.)

Engine Oil

Add the specified amount and type of engine oil. (Refer to Section D.)

Coolant

Close the drain plug; then fill the radiator and reservoir tank with the specified amount and type of coolant. (Refer to Section E.)

Check Engine Condition

1. Check for leaks.
2. Connect the negative battery cable.
3. Perform engine adjustments if necessary.
4. Perform a road test.
5. Recheck the oil and coolant levels.

97U0CX-213