

1989 Mazda RX-7 Factory Service Manual

This Online/PC version of the Manual has been brought to you by “Scott 89t2” and www.1300cc.com

Thanks to those who are hosting it for me.



Some parts of the manual may be hard to read or see on the screen, but if you print the pages out it's perfect. Well except for the crookedness ☺.

***Terms of Use:** This online/PC copy of the manual is only to be used and in your possession if you already own the printed version. It is for backup purposes only in case yours (or part of) is lost or damaged. If you downloaded this manual by mistake, Please Remove it from your possession. I also take no responsibility for what you do to yourself or your car while you use this manual.

CLUTCH

INDEX	H- 2
OUTLINE	H- 3
SPECIFICATIONS.....	H- 3
TROUBLESHOOTING GUIDE	H- 3
CLUTCH FLUID	H- 4
PREPARATION.....	H- 4
REPLACEMENT.....	H- 4
CLUTCH PEDAL	H- 5
ADJUSTMENT.....	H- 5
REMOVAL, INSPECTION, AND INSTALLATION.....	H- 6
CLUTCH MASTER CYLINDER	H- 7
PREPARATION.....	H- 7
REMOVAL AND INSTALLATION.....	H- 7
AIR BLEEDING.....	H- 8
OVERHAUL.....	H- 9
CLUTCH RELEASE CYLINDER	H-11
PREPARATION.....	H-11
REMOVAL AND INSTALLATION.....	H-11
AIR BLEEDING (REFER TO PAGE H-8.)	
OVERHAUL.....	H-12
CLUTCH UNIT	H-13
PREPARATION.....	H-13
REMOVAL AND INSTALLATION.....	H-14
RELEASE BEARING	H-16
INSPECTION.....	H-16
CLUTCH COVER	H-16
INSPECTION.....	H-16
CLUTCH DISC	H-17
INSPECTION.....	H-17
FLYWHEEL	H-17
INSPECTION.....	H-17

INDEX

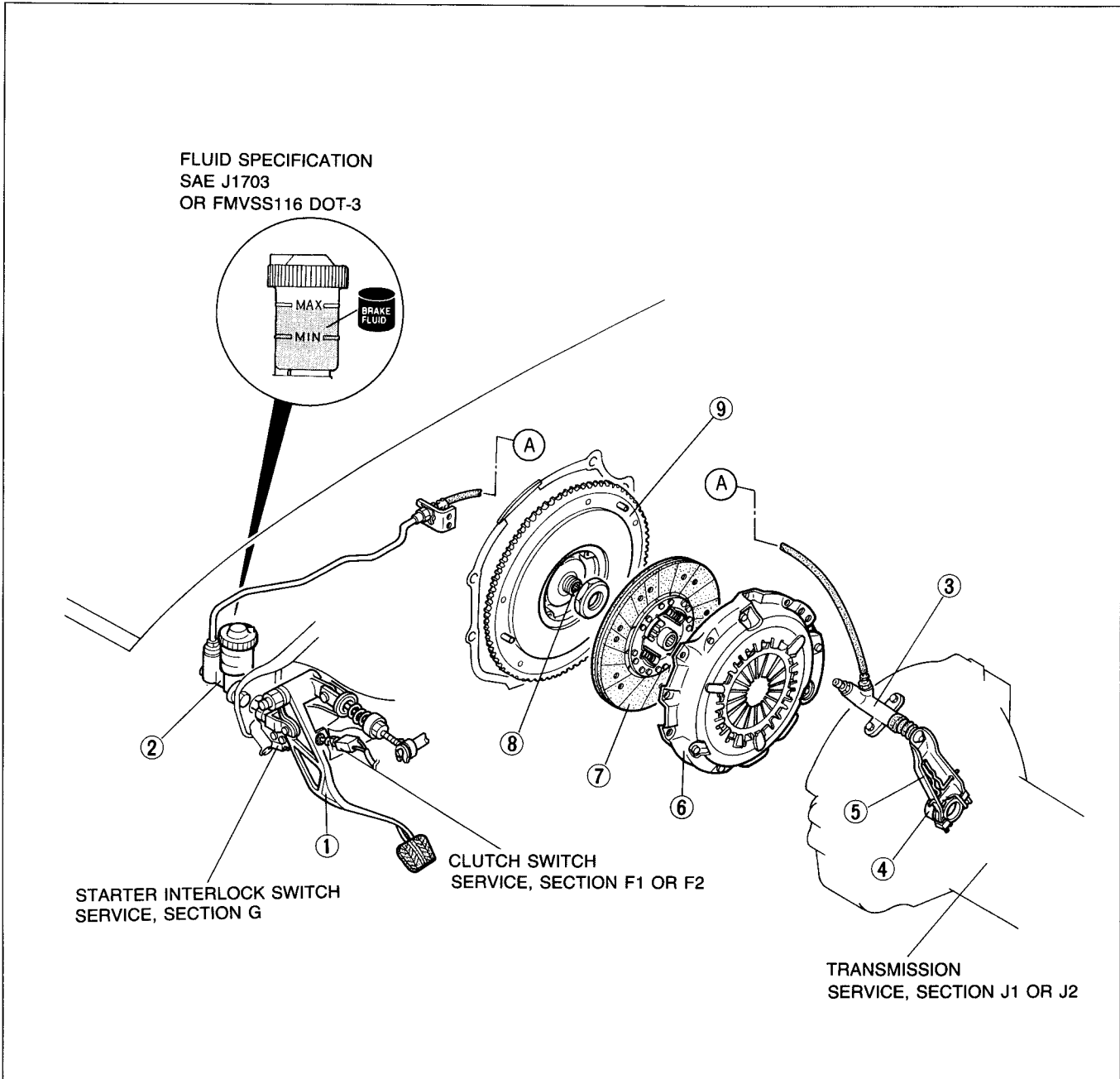

97U0HX-002

- | | | |
|---|--|--|
| 1. Clutch pedal
Adjustment..... page H- 5
Removal, Inspection, and
Installation..... page H- 6 | 4. Release bearing
Removal and
Installation..... page H-14
Inspection page H-16 | 7. Clutch disc
Removal and
Installation..... page H-14
Inspection page H-17 |
| 2. Clutch master cylinder
Removal and
Installation..... page H- 7
Overhaul..... page H- 9
Air bleeding page H- 8 | 5. Release fork
Removal and
Installation..... page H-14 | 8. Pilot bearing Section C |
| 3. Clutch release cylinder
Removal and
Installation..... page H-11
Overhaul..... page H-12
Air bleeding page H- 8 | 6. Clutch cover
Removal and
Installation..... page H-14
Inspection page H-16 | 9. Flywheel
Removal and
Installation..... page H-14
Inspection page H-17 |

OUTLINE

SPECIFICATIONS

Item		Model	Turbo	Non-Turbo	
Clutch control			Hydraulic		
Clutch cover	Type		Diaphragm spring		
	Set load	N (kg, lb)	6,867 (700, 1,540)	5,199 (530, 1,166)	
Clutch disc	Outer diameter	mm (in)	230 (9.06)	225 (8.86)	
	Inner diameter	mm (in)	155 (6.10)	150 (5.91)	
	Thickness	Pressure plate side	mm (in)	3.2 (0.13)	
		Flywheel side	mm (in)	3.2 (0.13)	
Clutch pedal	Type		Suspended		
	Pedal ratio		6.35		
	Full stroke	mm (in)	135 (5.31)		
	Height	mm (in)	183—193 (7.20—7.60)		
Master cylinder inner diameter		mm (in)	15.87 (0.625)		
Release cylinder inner diameter		mm (in)	19.05 (0.750)		
Clutch fluid			SAE J1703 or FMVSS116 DOT-3		

97U0HX-003

TROUBLESHOOTING GUIDE

Problem	Possible Cause	Action	Page
Slipping	Clutch disc facing worn excessively	Replace	H-14
	Clutch disc facing surface hardened or oil on surface	Repair or replace	H-14
	Pressure plate damaged	Repair or replace	H-14
	Diaphragm spring damaged or weak	Replace	H-14
	Insufficient clutch pedal play	Adjust	H- 5
	Clutch pedal sticking	Repair or replace	H- 6
	Flywheel damaged	Repair or replace	H-14
Faulty disengagement	Excessive runout or damaged clutch disc	Replace	H-14
	Clutch disc splines rusted or worn	Remove rust or replace	H-14
	Oil on facing	Repair or replace	—
	Diaphragm spring weak	Replace	H-14
	Excessive clutch pedal play	Adjust	H- 5
	Insufficient clutch fluid	Add fluid	H- 2
	Leakage of clutch fluid	Locate and repair or replace	—
Clutch vibrates when accelerating	Oil on facing	Repair or replace	H-14
	Torsion spring weak	Replace	H-14
	Clutch disc facing hardened or damaged	Repair or replace	H-14
	Clutch disc facing rivets loose	Replace	H-14
	Pressure plate damaged or excessive runout	Replace	H-14
	Flywheel surface hardened or damaged	Repair or replace	H-14
	Loose or worn engine mount	Tighten or replace	—
Clutch pedal sticking	Pedal shaft not properly lubricated	Lubricate or replace	H- 6
Abnormal noise	Clutch release bearing damaged	Replace	H-14
	Poor lubrication of release bearing sleeve	Lubricate or replace	H-14
	Torsion spring weak	Replace	H-14
	Excessive eccentric shaft end play	Repair	Refer to Section C
	Pilot bearing worn or damaged	Replace	H-14
	Worn pivot points of release fork	Repair or replace	H-14

97U0HX-004

CLUTCH FLUID

PREPARATION

SST

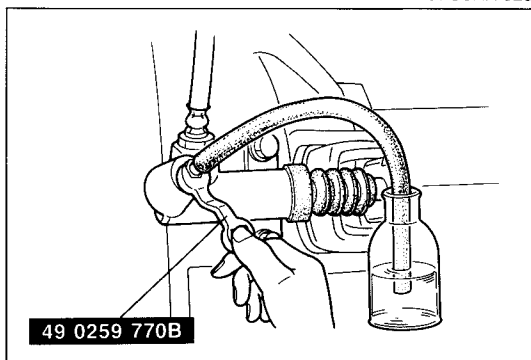
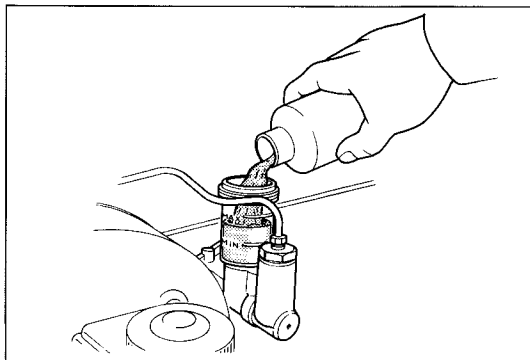
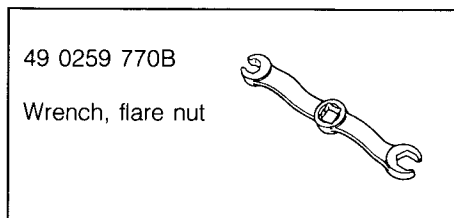

REPLACEMENT

Note

The fluid in the reserve tank must be maintained at the 3/4 level or higher during replacement.

Caution

- a) Be careful not to spill clutch fluid on a painted surface. If this should happen, wash it off immediately.
- b) Do not mix different brands of clutch fluid.
- c) Do not reuse the clutch fluid which was drained out.

1. Draw the fluid from the reserve tank with a suction pump, and refill with clean new fluid.
2. Remove the bleeder cap from the clutch release cylinder and attach a vinyl hose to the bleeder plug.
3. Place the other end of the vinyl hose in a container.
4. Slowly pump the clutch pedal several times.
5. With the clutch pedal depressed, loosen the bleeder screw with the **SST** to let fluid escape. Close the bleeder screw with the **SST**.
6. Repeat Steps 4 and 5 until only clean fluid is seen.
7. Tighten the bleeder screw.

Tightening torque:

5.9—8.8 N·m (60—90 cm·kg, 52—78 in·lb)

8. Add fluid to the MAX mark.
9. Check for correct clutch operation.

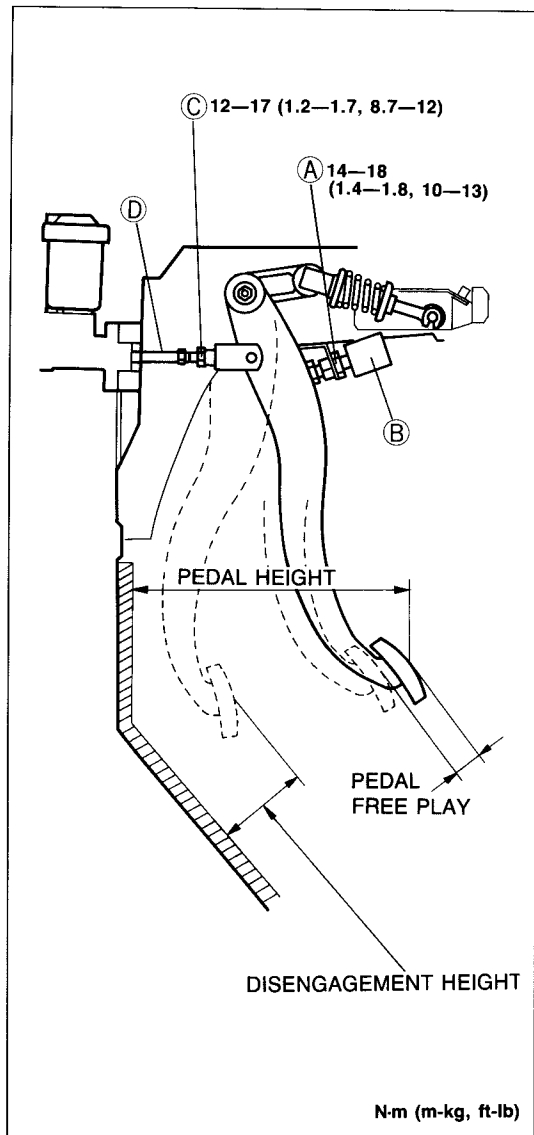

CLUTCH PEDAL

ADJUSTMENT

Clutch Pedal Height Inspection

Measure the distance from the upper surface of the pedal pad to the carpet.

**Pedal height: 183—193mm (7.20—7.60 in)
(With carpet)**

If necessary, adjust the pedal height.

Adjustment

1. Loosen locknut (A) and turn clutch switch (B) until the height is correct.
2. Tighten locknut (A).

Tightening torque:

14—18 N·m (1.4—1.8 m-kg, 10—13 ft-lb)

3. After the adjustment, inspect the pedal free play.

Clutch Pedal Free Play

Inspection

Depress the clutch pedal by hand until clutch resistance is felt.

**Pedal free play: 0.6—3.0mm (0.02—0.12 in)
Total pedal free play: 5—13mm (0.20—0.51 in)**

If necessary, adjust the pedal free play.

Adjustment

1. Loosen locknut (C) and turn push rod (D) until pedal free play is correct.
2. Check that the disengagement height from the upper surface of the pedal height to the carpet is correct when the pedal is fully depressed.

**Minimum disengagement height: 54mm (2.13 in)
(With carpet)**

3. Tighten locknut (C).

Tightening torque:

12—17 N·m (1.2—1.7 m-kg, 8.7—12 ft-lb)

4. After adjustment, inspect the pedal height.

H CLUTCH PEDAL

REMOVAL, INSPECTION, AND INSTALLATION

Remove in the order shown in the figure.
Inspect all parts and repair or replace as necessary.
Install in the reverse order of removal.

Note

Apply white grease to the bushings and pins when installing.

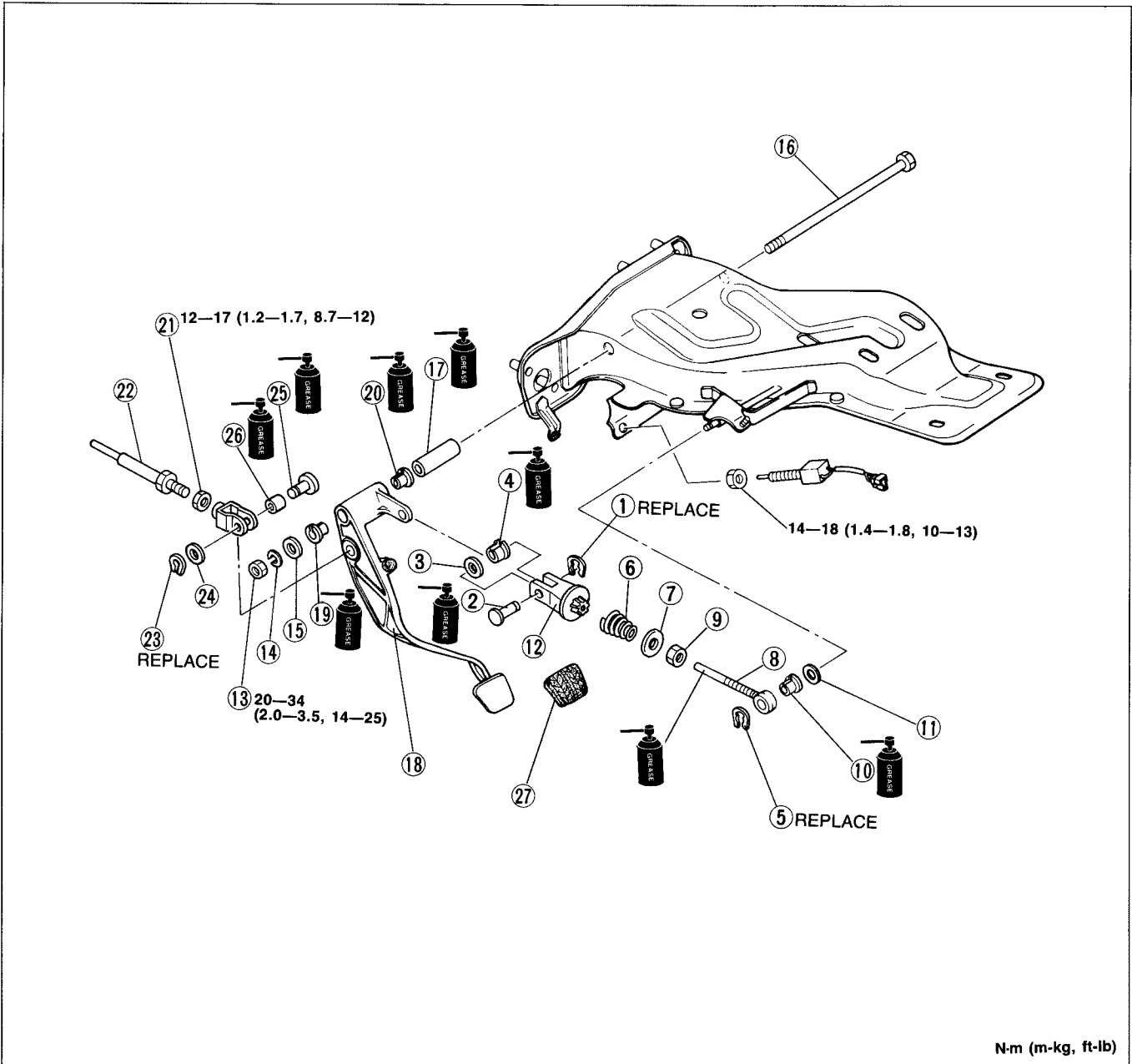

N-m (m-kg, ft-lb)

97U0HX-007

- | | | |
|---------------------------|---------------------------|-------------------------------|
| 1. Clip | 11. Spacer | 20. Bushing |
| 2. Pin | 12. Spring seat | 21. Nut |
| 3. Spacer | 13. Nut | 22. Push rod |
| 4. Bushing | 14. Lock washer | Inspect for damage or bending |
| 5. Clip | 15. Spacer | 23. Clip |
| 6. Assist spring | 16. Bolt | 24. Spacer |
| Adjustment..... page H- 7 | 17. Spacer | 25. Pin |
| 7. Spring seat | 18. Clutch pedal | 26. Bushing |
| 8. Clutch pedal rod | Adjustment..... page H- 5 | 27. Pedal pad |
| 9. Assist spring nut | 19. Bushing | |
| 10. Bushing | | |

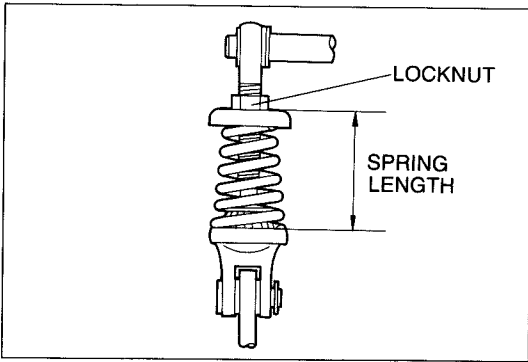

97U0HX-008

Adjustment Assist spring

Turn the locknut until the spring length is correct.

Standard spring length:

Turbo: 36.5—37.5mm (1.44—1.48 in)

Non-Turbo: 38.5—39.5mm (1.52—1.56 in)

Clutch pedal height and free play

Refer to page H—5

CLUTCH MASTER CYLINDER

PREPARATION

SST

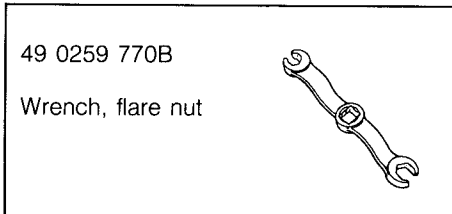

9MU0HX-011

REMOVAL AND INSTALLATION

Remove in the order shown in the figure, referring to **Removal Note**.
Install in the reverse order of removal, referring to **Installation Note**.

Caution

Clutch fluid will damage painted surfaces. Be sure to use a container or rags to collect it. If fluid does get on a painted surface, wipe it off immediately with a rag.

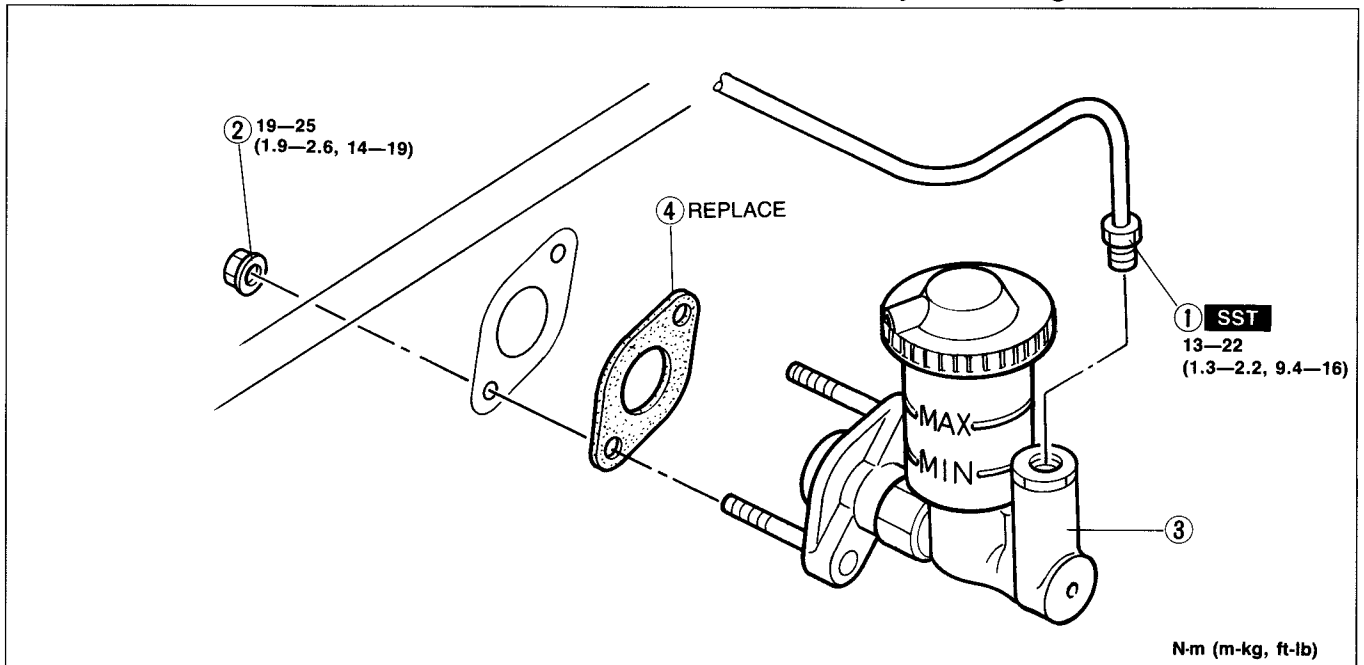

N·m (m·kg, ft·lb)

97U0HX-009

- 1. Clutch pipe
Removal..... page H— 8
Installation..... page H— 8
- 2. Nut

- 3. Clutch master cylinder
Overhaul..... page H— 9
Check for fluid leakage from
the cylinder bore.
AIR BLEEDING page H— 8

- 4. Gasket

H CLUTCH MASTER CYLINDER

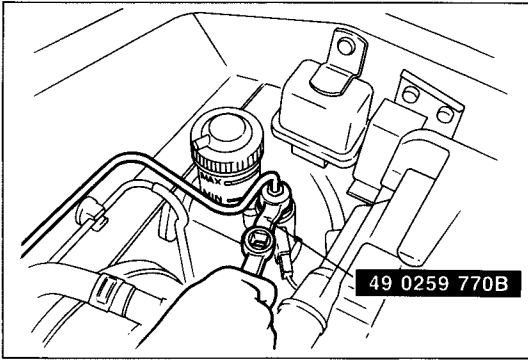

Removal Note

Clutch pipe

Disconnect the clutch pipe with the **SST**.

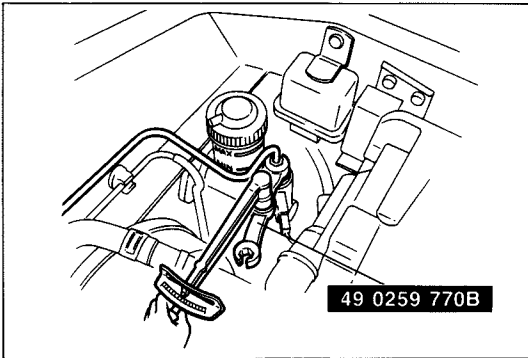

Installation Note

Clutch pipe

Tighten the clutch pipe with the **SST**.

Tightening torque:

13—22 N·m (1.3—2.2 m·kg, 9.4—16 ft·lb)

Air Bleeding

After installation, bleed the clutch system.
(Refer to below.)

Inspection and Adjustment

Clutch pedal height and free play

Refer to page H-5

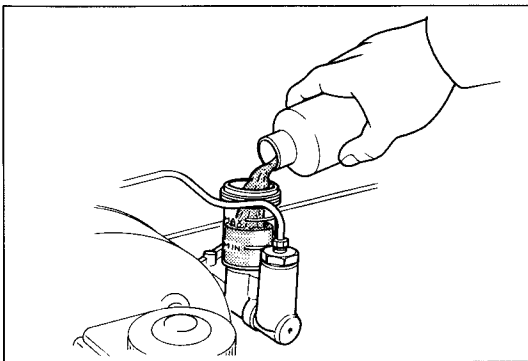

AIR BLEEDING

The clutch hydraulic system must be bled to remove air introduced whenever a hydraulic line is disconnected.

Note

The fluid in the reserve tank must be maintained at the 3/4 level or higher during air bleeding.

Caution

- a) **Clutch fluid will damage a painted surface. If fluid does get on a painted surface, wipe it off immediately.**
- b) **Do not mix different brands of clutch fluid.**
- c) **Do not reuse the clutch fluid which was drained out.**

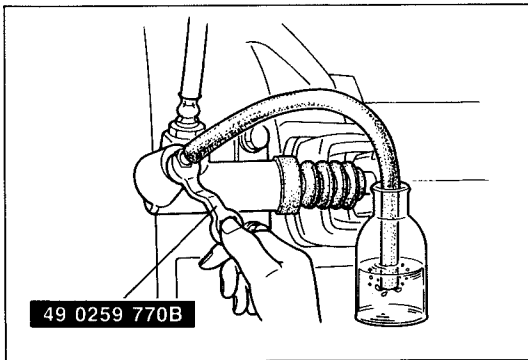

1. Remove the bleeder cap from the clutch release cylinder and attach a vinyl hose to the bleeder plug.
2. Insert the other end of the vinyl hose in a clear container.
3. Slowly pump the clutch pedal several times.
4. While depressing the pedal, loosen the bleeder screw with the **SST** to let fluid and air escape.
Close the bleeder screw with the **SST**.
5. Repeat Steps 3 and 4 until no air bubbles are seen in the fluid.
6. Tighten the bleeder screw.

Tightening torque:

5.9—8.8 N·m (60—90 cm·kg, 52—78 in·lb)

7. Check for correct clutch operation.
8. Verify that there is no fluid leakage.

OVERHAUL

Disassemble in the order shown in the figure, referring to **Disassembly Note**.

Inspect all parts and repair or replace as necessary.

Assemble in the reverse order of disassembly, referring to **Assembly Note**.

Caution

Clean the disassembled parts in solvent and blow through all ports and passages with compressed air.

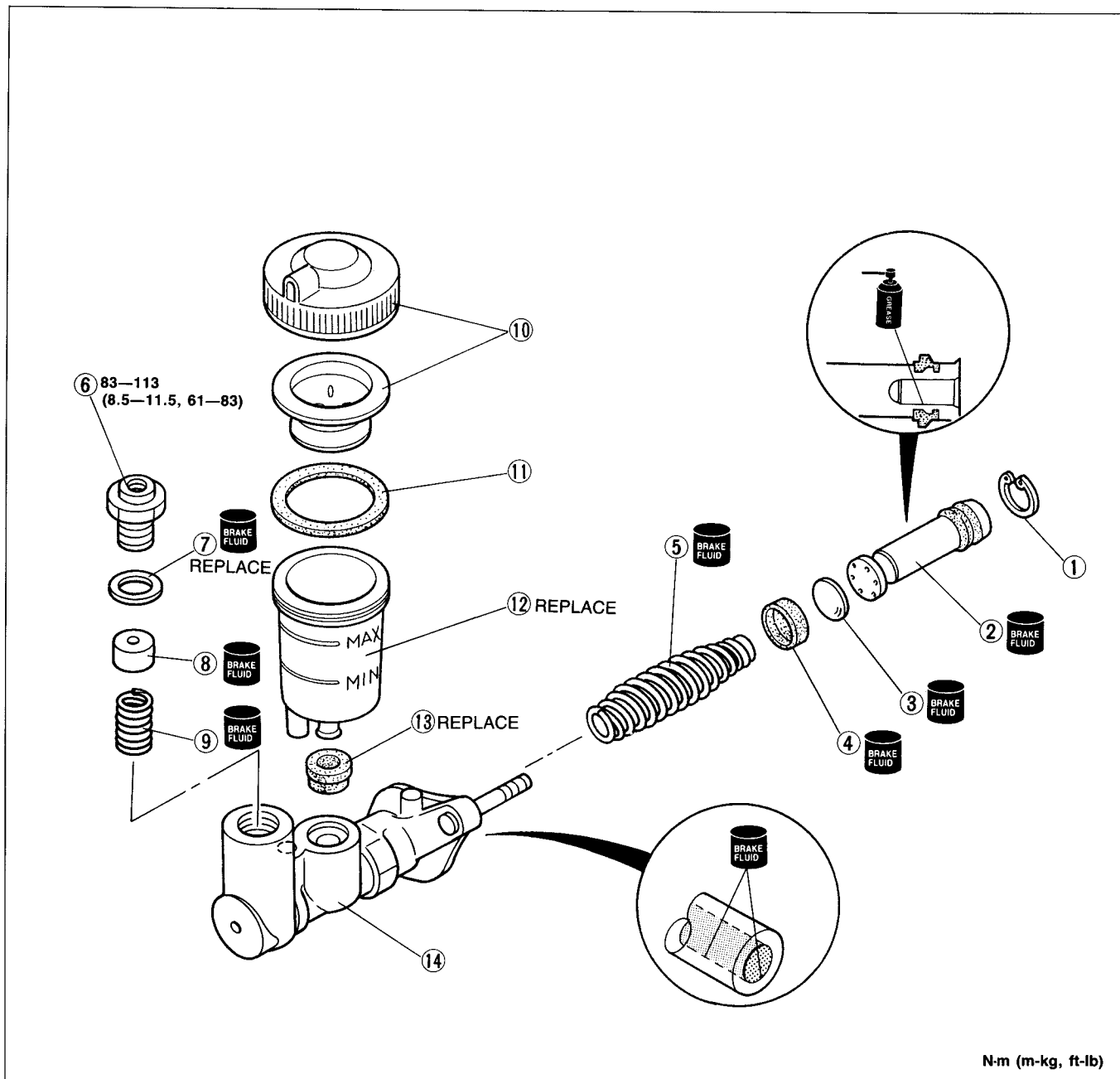

N-m (m-kg, ft-lb)

97U0HX-011

- 1. Snap ring
Removal..... page H-10
Installation..... page H-11
- 2. Piston and secondary cup assembly
Removal..... page H-10
Inspect for wear, scoring, or cracks
Installation..... page H-10

- 3. Spacer
- 4. Primary cup
Inspect for wear or cracks
- 5. Return spring
- 6. Joint bolt
- 7. Packing
- 8. One-way valve piston
Removal..... page H-10

- 9. Return spring
- 10. Tank cap baffle
- 11. Packing
- 12. Reserve tank
- 13. Bushing
- 14. Master cylinder body
Inspect cylinder bore for scoring or corrosion

H CLUTCH MASTER CYLINDER

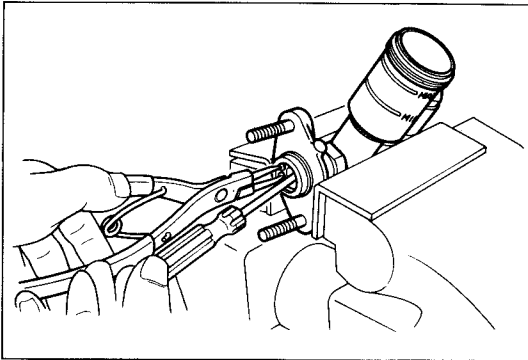

9MU0HX-018

Disassembly Note Snap ring

Note

Do not damage the push rod contact surface of the piston.

Press down on the piston and remove the snap ring with snap ring pliers.

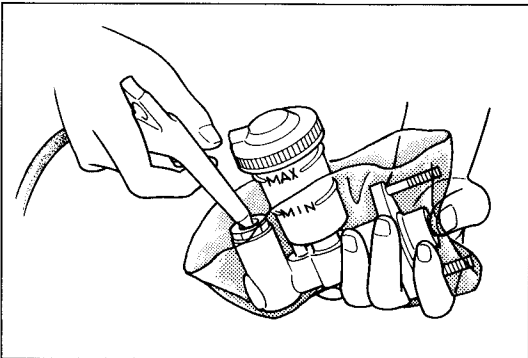

9MU0HX-019

Piston and secondary cup assembly

Caution

Hold a rag over the master cylinder to prevent the piston and secondary cup assembly from jumping out.

Remove the piston and secondary cup assembly, spacer, and primary cup by applying compressed air through the clutch pipe installation hole.

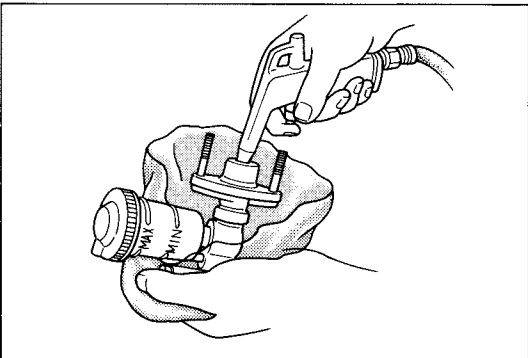

9MU0HX-020

One-way valve piston and return spring

Caution

Hold a rag over the master cylinder to prevent the piston and spring from jumping out.

Remove the piston by applying compressed air through the cylinder bore.

Assembly Note

Caution

- Before assembly, make sure all parts are completely clean.**
- Do not mix different brands of clutch fluid.**
- Do not reuse the clutch fluid which was drained out.**
- Apply the specified clutch fluid to the piston and secondary cup assembly, spacer, primary cup, and cylinder bore before assembly.**
- Replace parts with new ones whenever specified to do so.**

9MU0HX-021

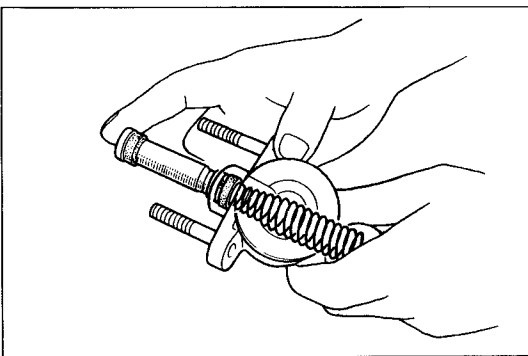

9MU0HX-022

Piston and secondary cup assembly

Install the spring, primary cup, spacer, and piston and secondary cup assembly, noting the proper direction of the parts. (Refer to page H-9.)

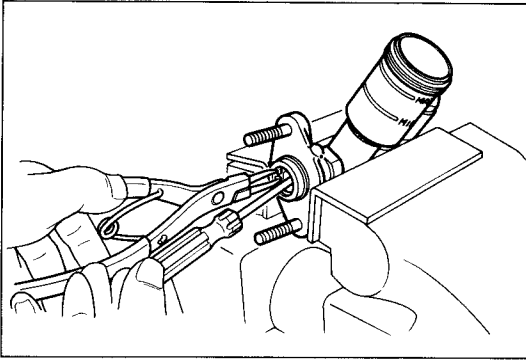

9MU0HX-023

Snap ring

Note

Do not damage the push rod contact surface of the piston.

While pressing the piston, install the snap ring.

CLUTCH RELEASE CYLINDER

PREPARATION

SST

49 0259 770B
Wrench, flare nut

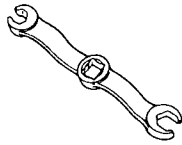

9MU0HX-024

REMOVAL AND INSTALLATION

Remove in the order shown in the figure, referring to **Removal Note**.
Install in the reverse order of removal, referring to **Installation Note**.

Caution

Clutch fluid will damage painted surfaces. Be sure to use a container or rags to collect it. If fluid does get on a painted surface, wipe it off immediately with a rag.

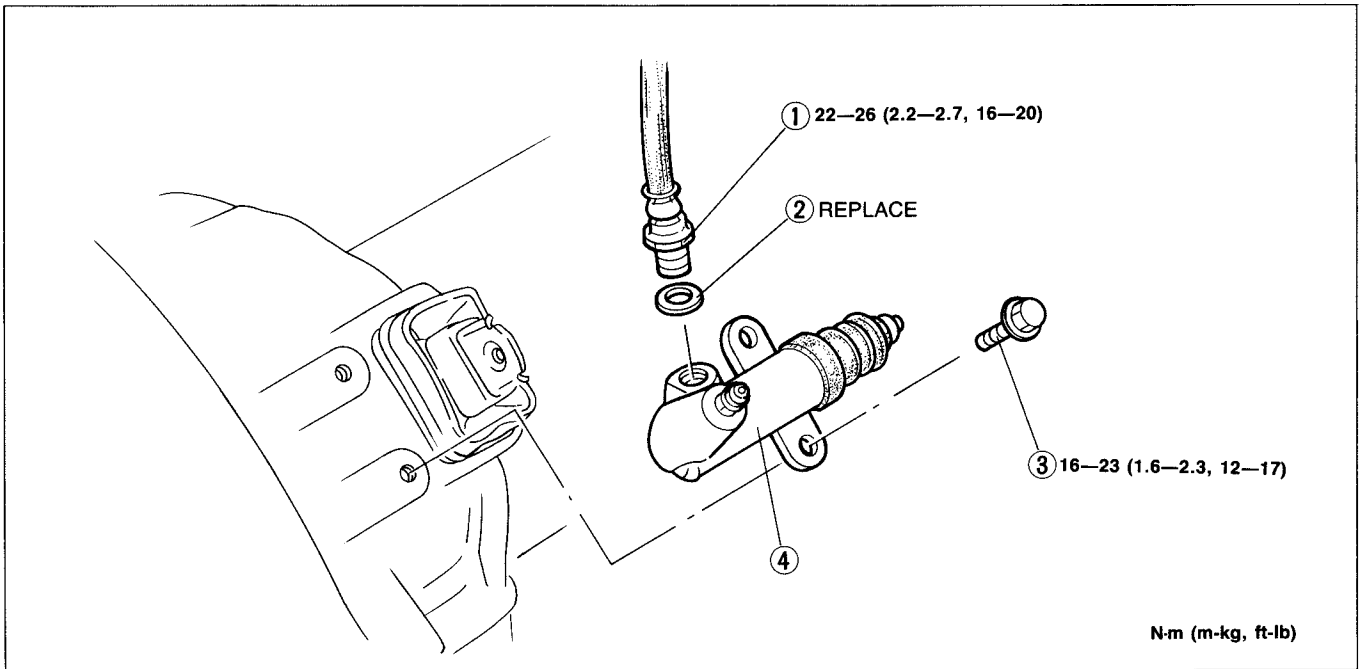

97U0HX-012

- 1. Flexible hose
Removal page H-12
Installation page H-12
- 2. Packing
- 3. Bolt

- 4. Clutch release cylinder
Remove boot and check for fluid leakage
Overhaul..... page H-12
AIR BLEEDING page H- 8

H CLUTCH RELEASE CYLINDER

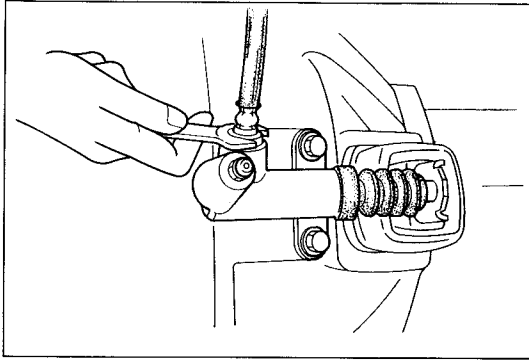

97U0HX-027

Removal Note Flexible hose

Caution

- a) After disconnecting the flexible hose, plug the flexible hose to prevent fluid leakage.
- b) Do not twist the flexible hose.

Disconnect the flexible hose.

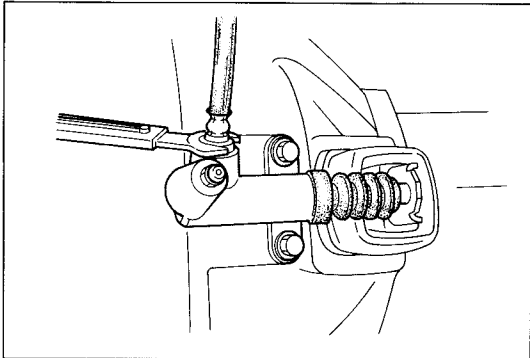

97U0HX-013

Installation Note Flexible hose

Tighten the flexible hose.

Tightening torque:

22—26 N·m (2.2—2.7 m·kg, 16—20 ft·lb)

Air Bleeding

After installation, bleed the clutch system.
(Refer to page H-8.)

OVERHAUL

Disassemble in the order shown in the figure, referring to **Disassembly Note**.
Inspect all parts and repair or replace as necessary.
Assemble in the reverse order of disassembly.

Caution

- a) Clean the disassembled parts in solvent and blow through all ports and passages with compressed air.
- b) Before assembly, make sure all parts are completely clean.
- c) Apply the specified clutch fluid to the piston and cup assembly and cylinder bore before assembly.

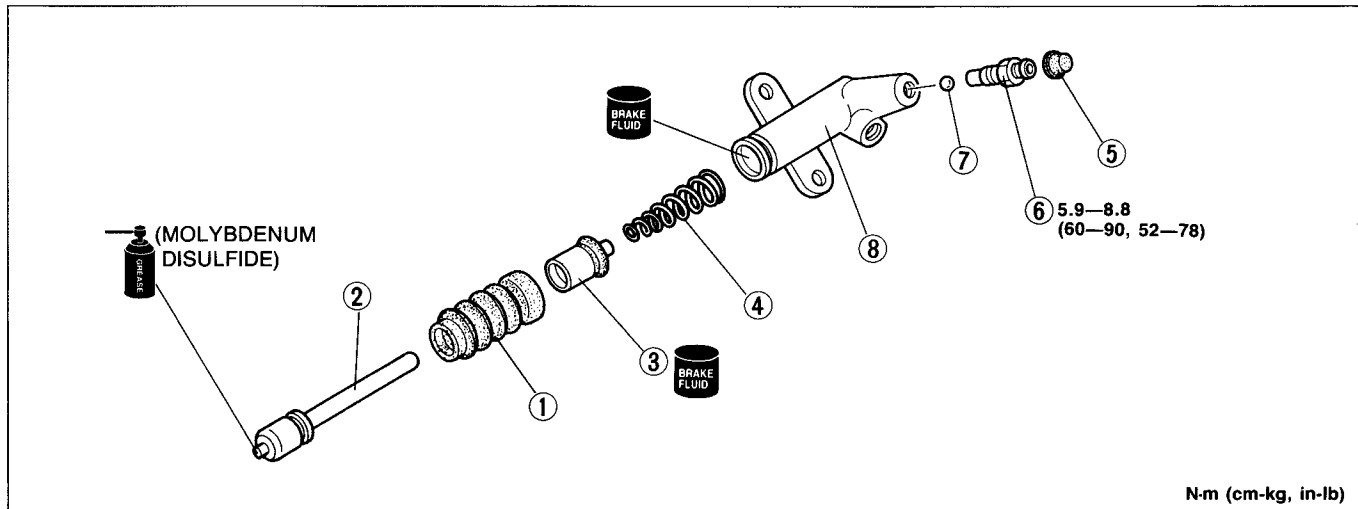

N·m (cm·kg, in·lb)

9MU0HX-028

- | | | |
|---|------------------|---|
| 1. Boot | 4. Spring | 8. Release cylinder body
Inspect cylinder bore for
scoring or corrosion |
| 2. Push rod | 5. Bleeder cap | |
| 3. Piston and cup assembly
Removal..... page H-13
Inspect for wear, scoring,
or cracks | 6. Bleeder screw | |
| | 7. Steel ball | |

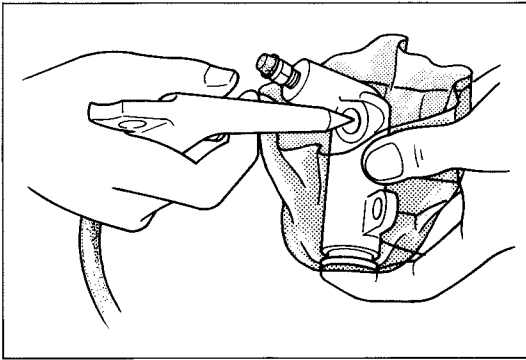

9BU0HX-019

Disassembly Note
Piston and cup assembly

Caution
Hold a rag over the release cylinder to prevent the piston and cup assembly from jumping out.

Remove the piston and cup assembly by applying compressed air through the flexible hose installation hole.

CLUTCH UNIT

PREPARATION

SST

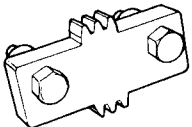
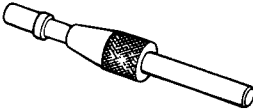
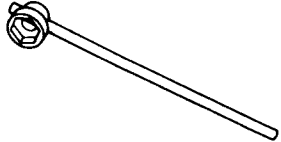
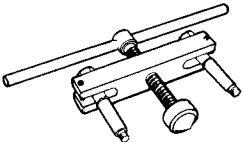
<p>49 F011 101 Brake, ring gear</p> 	<p>49 SE01 310 Centering tool, clutch disc</p> 	<p>49 0820 035 Box wrench, flywheel</p> 
<p>49 0839 305A Puller, counter weight</p> 	<p>97U0HX-014</p>	

H CLUTCH UNIT

REMOVAL AND INSTALLATION

Remove in the order shown in the figure, referring to **Removal Note**.
Install in the reverse order of removal, referring to **Installation Note**.

Note

- a) Remove the clutch release cylinder with the flexible hose connected.
- b) Do not remove the pilot bearing if not necessary.

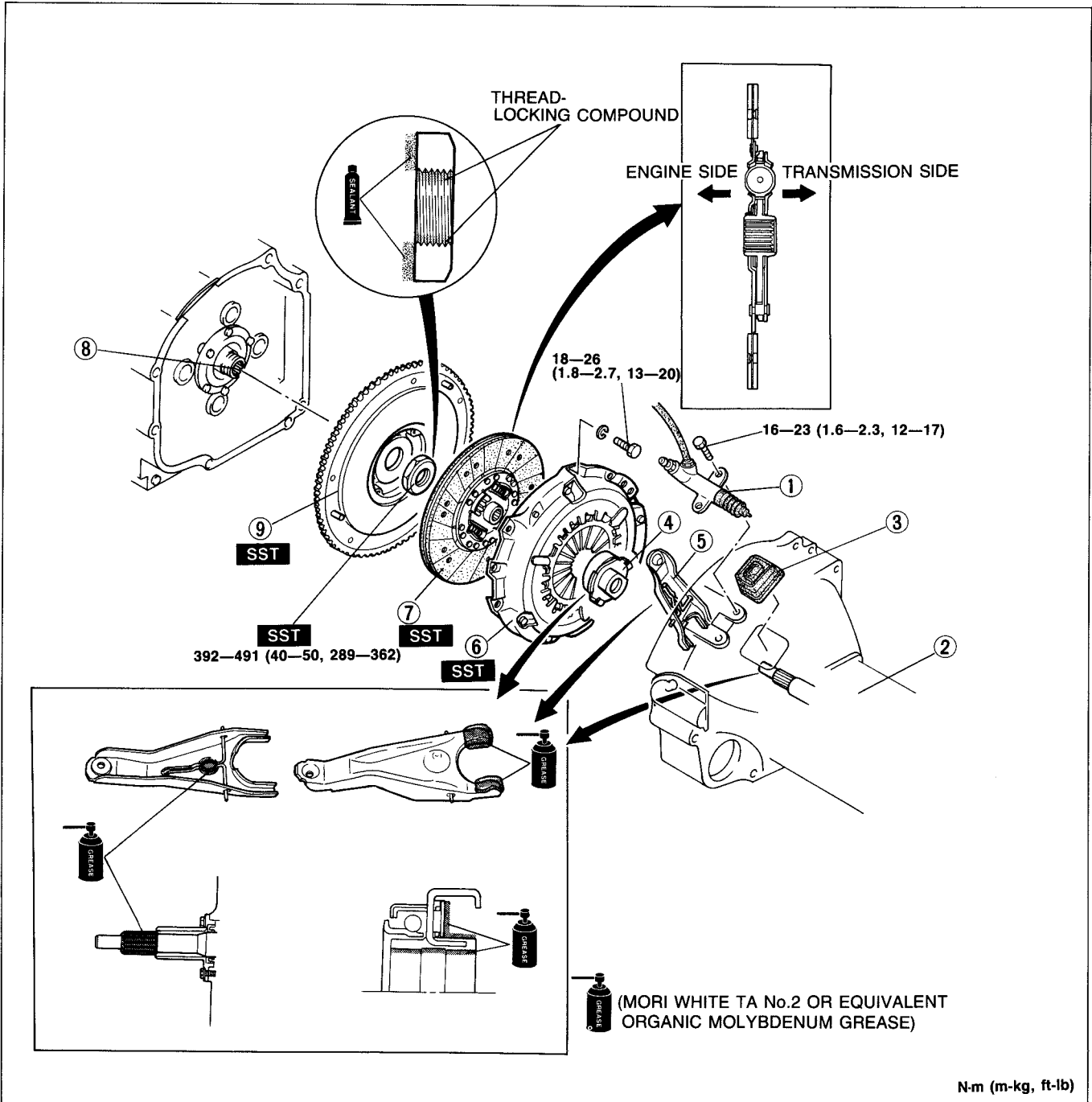

97U0HX-015

- | | | |
|-------------------------------|-----------------------------|----------------------------------|
| 1. Clutch release cylinder | 6. Clutch cover | 8. Pilot bearing Section C |
| 2. Transmission | Removal..... page H-15 | 9. Flywheel |
| Service..... Section J1 or J2 | Inspection page H-16 | Removal..... page H-15 |
| 3. Boot | Installation..... page H-16 | Inspection page H-17 |
| 4. Release bearing | 7. Clutch disc | Installation..... page H-15 |
| Inspection page H-16 | Removal..... page H-15 | |
| 5. Release fork | Inspection page H-17 | |
| | Installation..... page H-16 | |

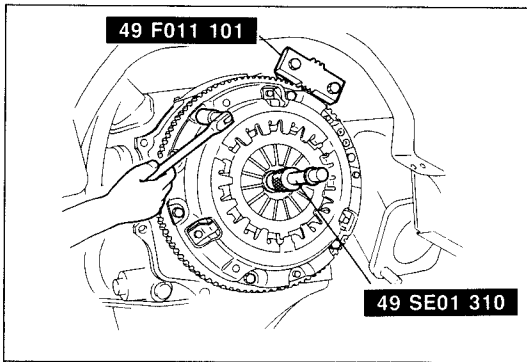

97U0HX-016

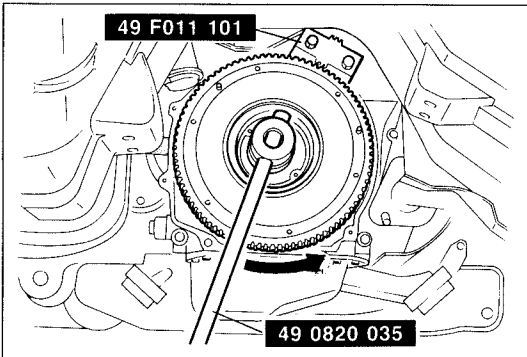

97U0HX-017

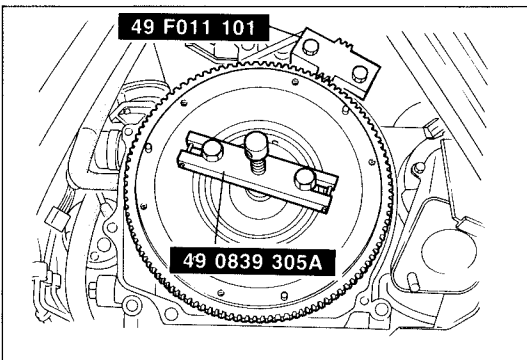

97U0HX-018

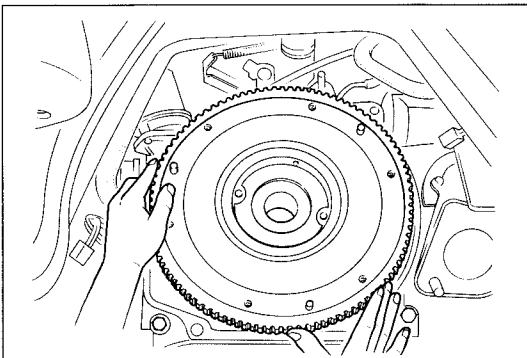

97U0HX-019

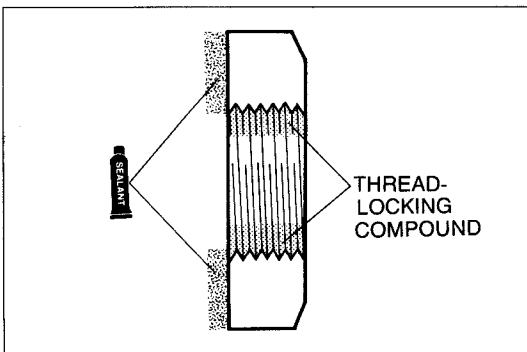

97U0HX-020

Removal Note

Clutch cover and disc

1. Install the **SST**.
2. Loosen each bolt one turn at a time in a crisscross pattern until spring tension is released. Then remove the clutch cover and disc.

Flywheel

1. Hold the flywheel with the **SST**.
2. Remove the locknut with the **SST**.

Note

After removing the flywheel, inspect for oil leakage past the eccentric shaft rear oil seal. If necessary replace it. (Refer to Section C)

3. Remove the flywheel with the **SST**.
4. Remove the key from the eccentric shaft.

Installation Note

Flywheel

1. Set the key in the eccentric shaft, then install the flywheel.
2. Apply thread-locking compound to the locknut threads.
3. Apply sealant to the contact surface of the locknut and flywheel.

H CLUTCH UNIT, RELEASE BEARING, CLUTCH COVER

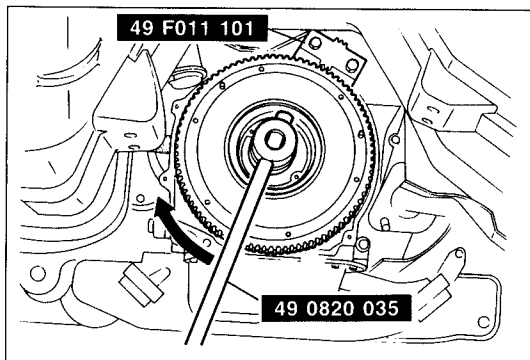

97U0HX-021

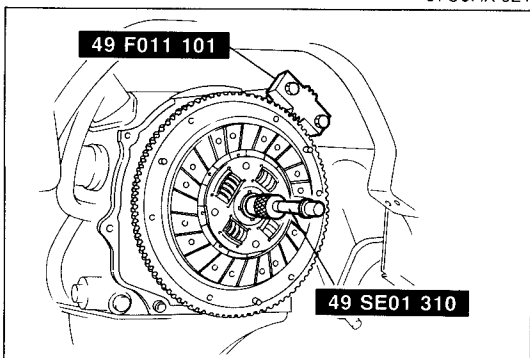

97U0HX-022

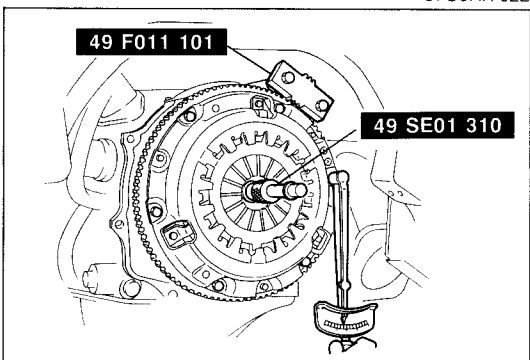

97U0HX-023

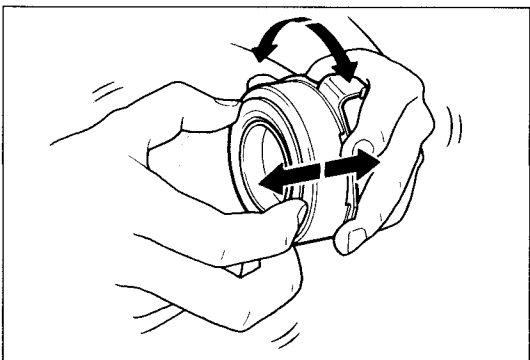

9MU0HX-040

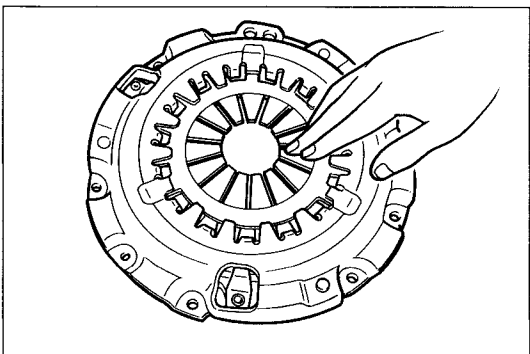

9MU0HX-041

4. Install the **SST**.
5. Tighten the locknut with the **SST**.

Tightening torque:

392—491 N·m (40—50 m·kg, 289—362 ft·lb)

Clutch disc

1. Clean the clutch disc splines and main drive gear splines, then apply Mori White TA No.2 or equivalent organic molybdeum grease.
2. Hold the clutch disc in position with the **SST**.

Clutch cover

1. Align the dowel holes with the flywheel dowels.
2. Tighten the bolts evenly and gradually in the pattern shown with the **SST**.

Tightening torque:

18—26 N·m (1.8—2.7 m·kg, 13—20 ft·lb)

RELEASE BEARING

INSPECTION

Turn the bearing while applying force in the axial direction. If the bearing sticks or has excessive resistance, replace it.

Note

The clutch release bearing is a sealed bearing and must not be washed in solvent.

CLUTCH COVER

INSPECTION

1. Inspect the contact surface of the clutch disc for scoring, cracks, or burning, repair or replace as necessary.

Note

Minor scoring or burning should be removed with emery paper.

2. Inspect the contact surface of the clutch release bearing for wear or cracks.

If there is wear or cracks, replace the clutch cover.

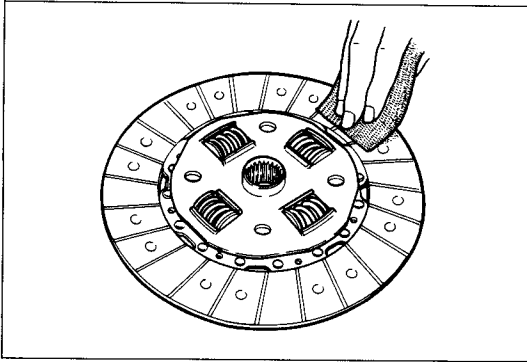

9MU0HX-042

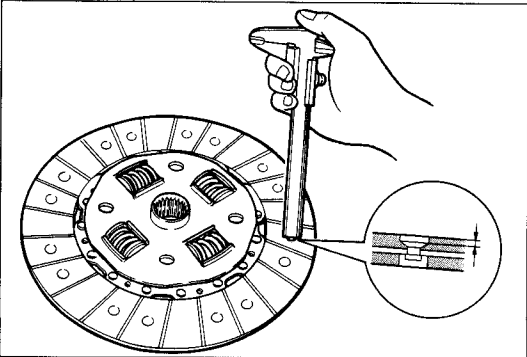

9MU0HX-043

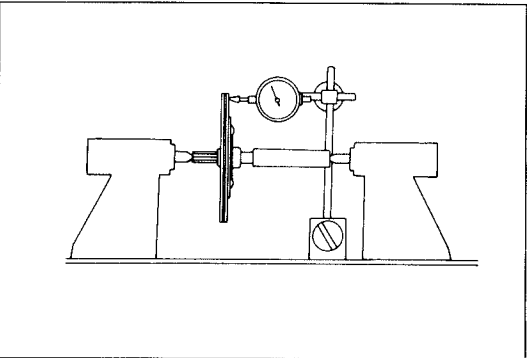

97U0HX-024

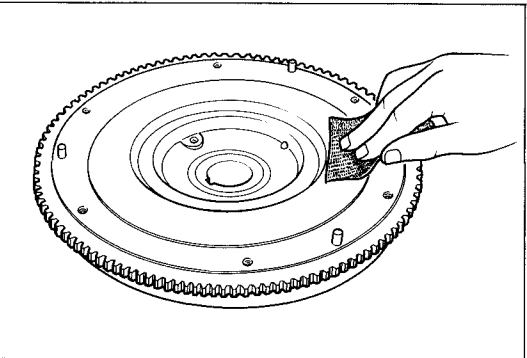

9MU0HX-046

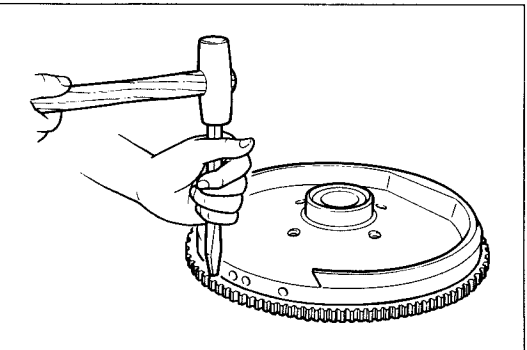

9MU0HX-047

CLUTCH DISC

INSPECTION

1. Inspect the lining surface for burning or oil contamination. Replace it if it is badly burned or oil soaked.

Note

Use sandpaper if the trouble is minor.

2. Inspect for loose facing rivets or torsion springs. Replace the clutch disc if any are loose.

3. Measure the thickness of the lining at a rivet head on both sides with vernier calipers. Replace it if less than minimum.

Minimum thickness: 0.3mm (0.012 in)

4. Measure the clutch disc runout with a dial indicator. Replace the clutch disc if runout is excessive.

Maximum runout: 0.7mm (0.028 in)

FLYWHEEL

INSPECTION

1. Inspect the contact surface of the clutch disc for scoring, cracks, or burning, repair or replace as necessary.

Note

Minor scoring or burning should be removed with emery paper.

2. Inspect the ring gear teeth for wear or damage. If necessary, replace the ring gear as follows:

- (1) Heat the ring gear with a blowtorch. Tap around the gear to remove it from the flywheel.
- (2) Heat the new ring gear to **250—300°C (480—570°F)**; then fit it onto the flywheel.

Note

The beveled side of the ring gear must face the engine side.

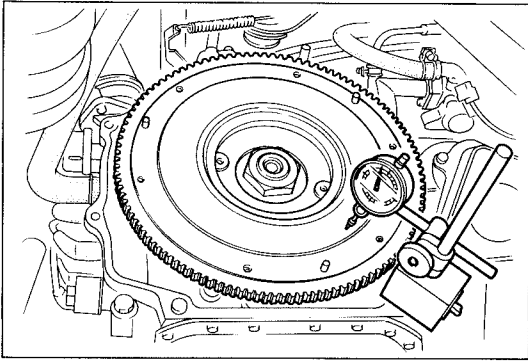

9MU0HX-048

3. Measure the flywheel runout with a dial indicator. Replace the flywheel if runout is excessive.

Maximum runout: 0.2mm (0.008 in)