

Parts Catalog

Mazda Rotary Pickup (U.S.A., '77 Model) (Final Edition)



MAZDA ROTARY ENGINE LICENSE NSU-WANKEL



Toyo Kogyo Co., Ltd.

© 1978 Toyo Kogyo Co., Ltd.
Sept. 1978

Model & Feature

This parts catalog was compiled for the following model :
Mazda Rotary Pickup for the U.S.A.
(production period 1977)

Model No.	Model/TYPE	State		T/Mission		Remarks
		Federal	California	Manual	Automatic	
3787	PA136-P	•		•		
3789	PA136-TC	•			•	
3790	PA136-PC		•	•		
3791	PA136-TC		•		•	

HOW TO USE THIS PARTS CATALOG

(I) Outline of Parts Catalog

This parts catalog consists of parts group index, illustrations, parts composition lists and part number index.

(II) How to locate parts

1) When part number is not known

- A. Refer to a parts group index and locate the group which your parts requirement would be located.



- B. Open to the illustration page according to the parts group index and locate the part wanted.



- C. See the key number given for the part in the illustration and find the corresponding number in the parts composition list.



- D. Then, you will find the part number and the name of the part adjacent to that key number.

2) When part number is known

- A. See a part number index at back of parts catalog and find the page where the part number and the key number are listed.





- B. Open to the page indicated and locate the part number in the parts composition list, then you will see the description, the quantity, etc.



- C. Moreover, you can see the illustration of part on the opposite page of the parts composition list by referring the key number.

(III) On Groups

- 1) The number enclosed with a triangle at the top of each page (Example ) indicates group number.
- 2) Group numbers are determined according to structure and function of parts.
- 3) The group numbers given in the parts group index at front of the parts catalog coincides with the numbers (Example ) in the illustrations and parts composition lists.

(VI) Definition of the following marks

- 1) 73/7 This is an example for an effective date of modification.
73 shows 1973 year and 7 means July (7th month of year).
- 2) ○ A new part and an old part are completely interchangeable.
- 3) × A new part and an old part are not interchangeable.
- 4) △ A new part can be used in place of old part but an old part can not be used in place of new part.
- 5) ● This dot at front of part number shows the part that is concerned in modifications since the last edition.
- 6) ○ The part with C is required to put a colour code after the part number in order to specify a colour.
- 7) ☆ The part marked thus is not available as a spare part, therefore order by the assembly unit or the set including this part.
- 8) ▲ Indication of Group.

(VII) Exhaust system certification regulations
(Applicable to California & Florida, U.S.A.)

All sound modifying devices listed within this catalogue are certified to comply with the exhaust system certification regulations contained in the California Administrative Code Title 13, Sections 1050 through 1054 and Florida Administrative Code Chapter 17-18, Part III for use on vehicles for which they are listed.

(Frame concerned : C7 ~ D7)

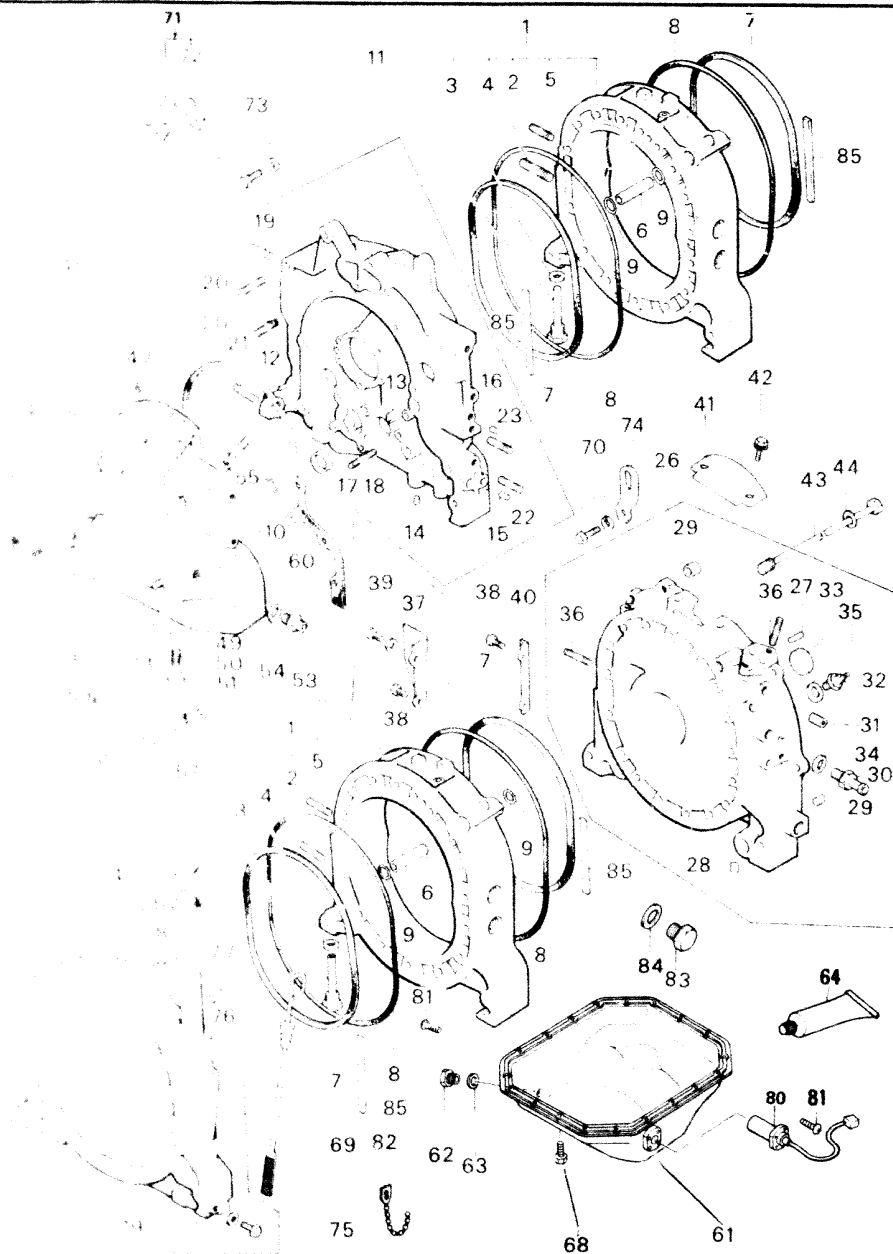

No.	Part Number	Description	Q'ty	Remarks
1	3775 10 100	Housing, Rotor	2	
2	0839 10 105	Stud	4	
3	1757 10 120	Nozzle, Air	4	
4	99564 1400	Gasket	4	
5	99851 0822 A	Stud	2	
6	1757 10 111	Dowel, Tubular	4	
7	1757 10 171 A	Ring, Square	4	
8	1757 10 172	Ring, "O"-Outer	4	
9	0813 10 173	Ring, "O"-Tubular Dowel	4	
10	8527 10 174	Ring, "O"-Front Cover	1	
11	3646 10 200	Housing, Front	1	
12	0839 10 203	Pin, Dowel	2	
13	2329 10 204	Dowel, Tubular	2	
14	0839 10 205	Plug, Blind	4	
15	1757 10 206 A	Plug, Blind	1	
16	1757 10 207	Plug, Blind	1	
17	99306 3000	Plug, Blind-Water	3	
18	99852 0660	Stud	2	

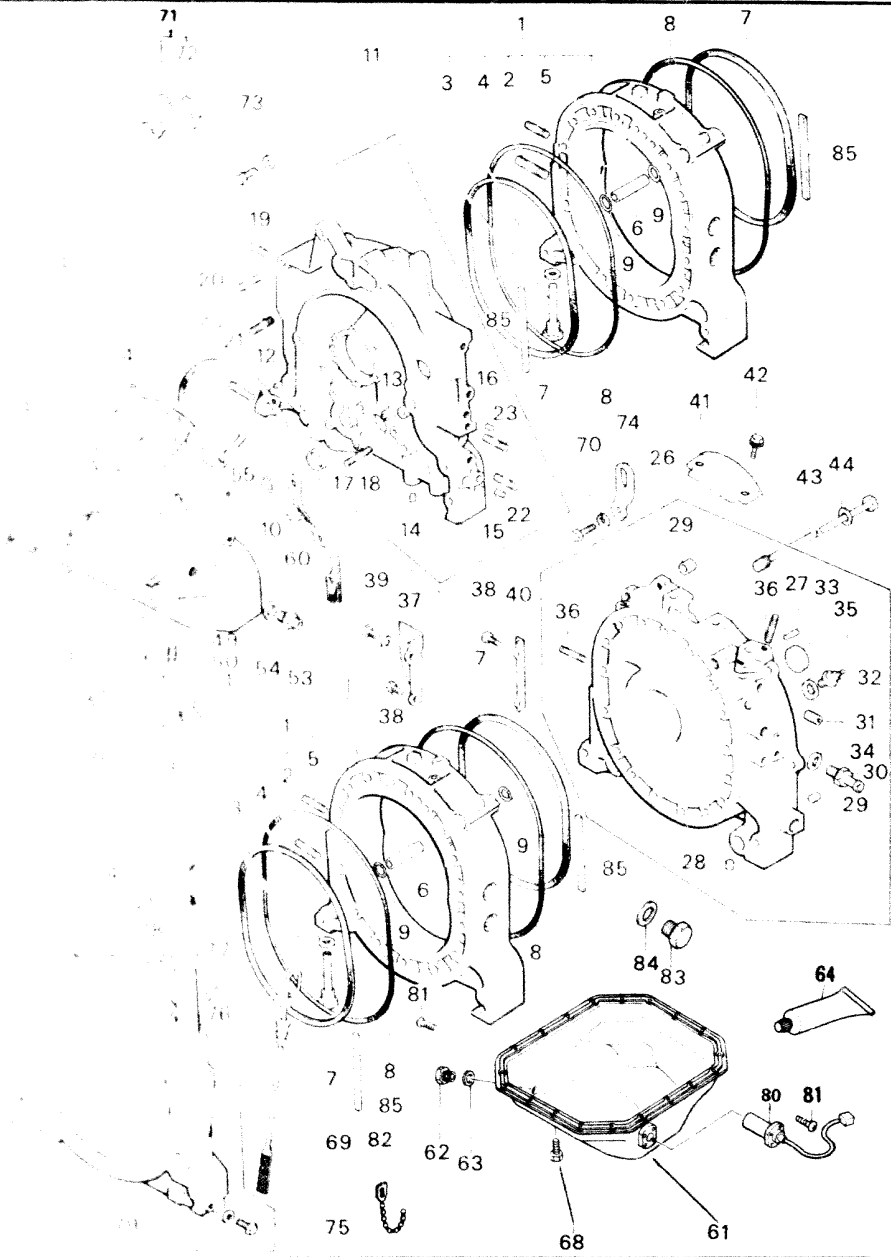

No.	Part Number	Description	Qty	Remarks
19	99852 0822 A	Stud. IN Manifold	2	
20	1757 10 208	Stud. Water Pump	4	
21	99852 1016	Stud	1	
22	99859 1220 A	Stud. Mounting	1	
23	99859 1225 A	Stud	1	
24	0324 10 250	Cap. Oil Filler	1	
• 24	0453 10 250	Cap. Oil Filler	1	77/5 ~ 0
25	0324 10 252	Gasket	1	
26	3648 23 050A	Housing, Rear	1	
27	0820 10 203	Pin. Knock-Gear	1	
28	0839 10 205	Plug. Blind	1	
29	1757 10 309	Pin. Tubular	2	
30	0866 10 320 A	Joint. Hose	1	
31	99503 1000 F	Plug	1	
32	1757 18 510 A	Gauge Unit. Heat	1	Selective use
	1881 18 510	Gauge Unit. Heat	1	
33	99306 3000	Plug. Blind-Water	5	
34	99562 1600	Gasket. Hose Joint	1	
35	99564 0800	Gasket. Heat Gauge Unit	1	

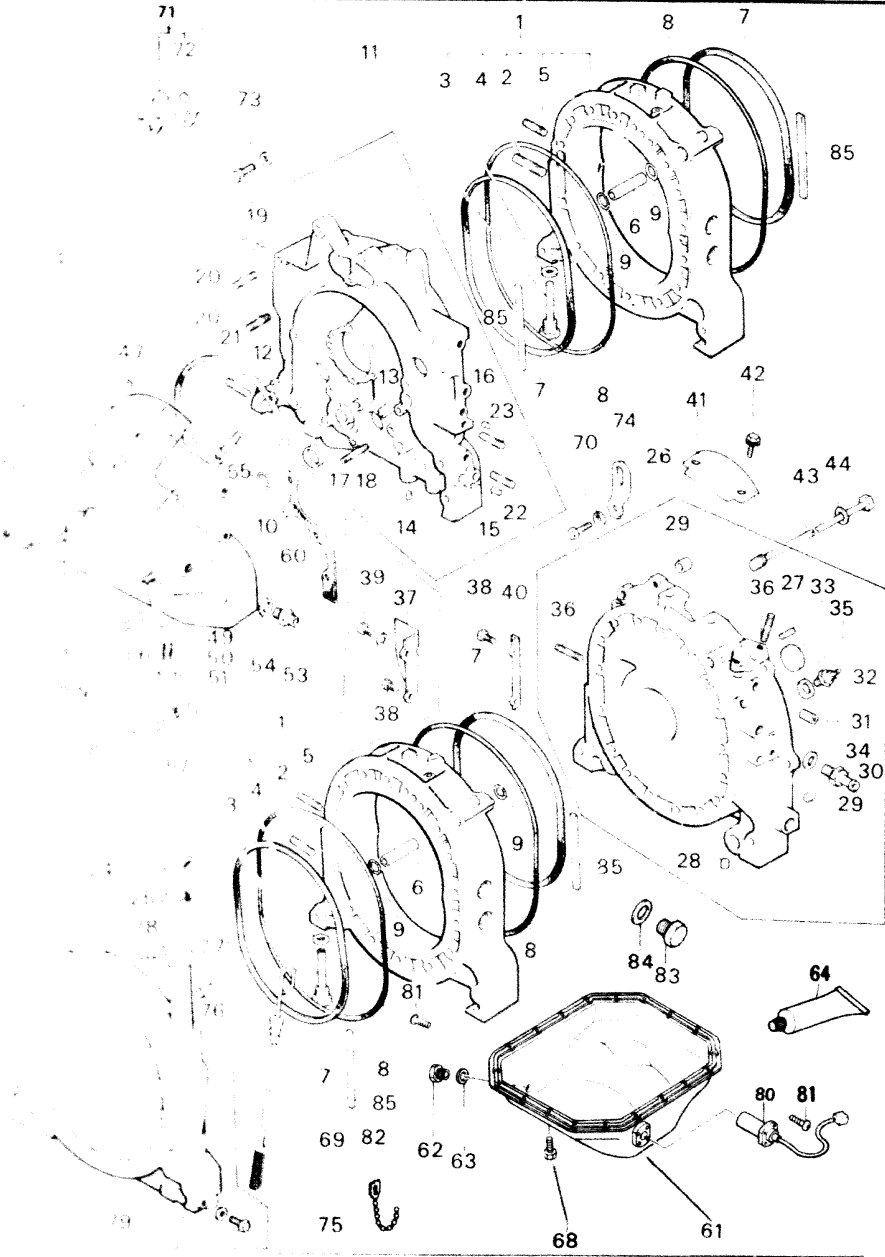

No.	Part Number	Description	Qty	Remarks
36	99852 0822A	Stud, IN Manifold & Oil Filler	4	
37	1029 10 305	Cover, Side Lower Automatic	1	
38	99796 0610	Bolt, Side Lower Cover	Automatic Manual 2	
39	99811 1010	Bolt	1	
	99971 1000	Washer, Spring	2	Automatic
40	1757 10 305	Cover, Dust	1	
41	1757 10 351	Cover, Dust	1	Manual
42	99796 0816	Bolt, Dust Cover	2	
43	1757 10 451	Bolt, Tension	17	
	1757 10 452	Bolt, Tension	1	
44	0839 10 455	Washer, Seal	18	
45	1757 10 600B	Cover, Front	1	
46	0820 10 605	Oil Seal	1	
47	1757 10 609	Pin, Spring	1	
48	0820 10 631B	Pin, Top Indicator	1	
49	0839 14 115	Plunger, Press	1	
50	0839 14 273A	Spring, Press Plunger	1	
51	0839 14 274	Plug, Press Plunger	1	

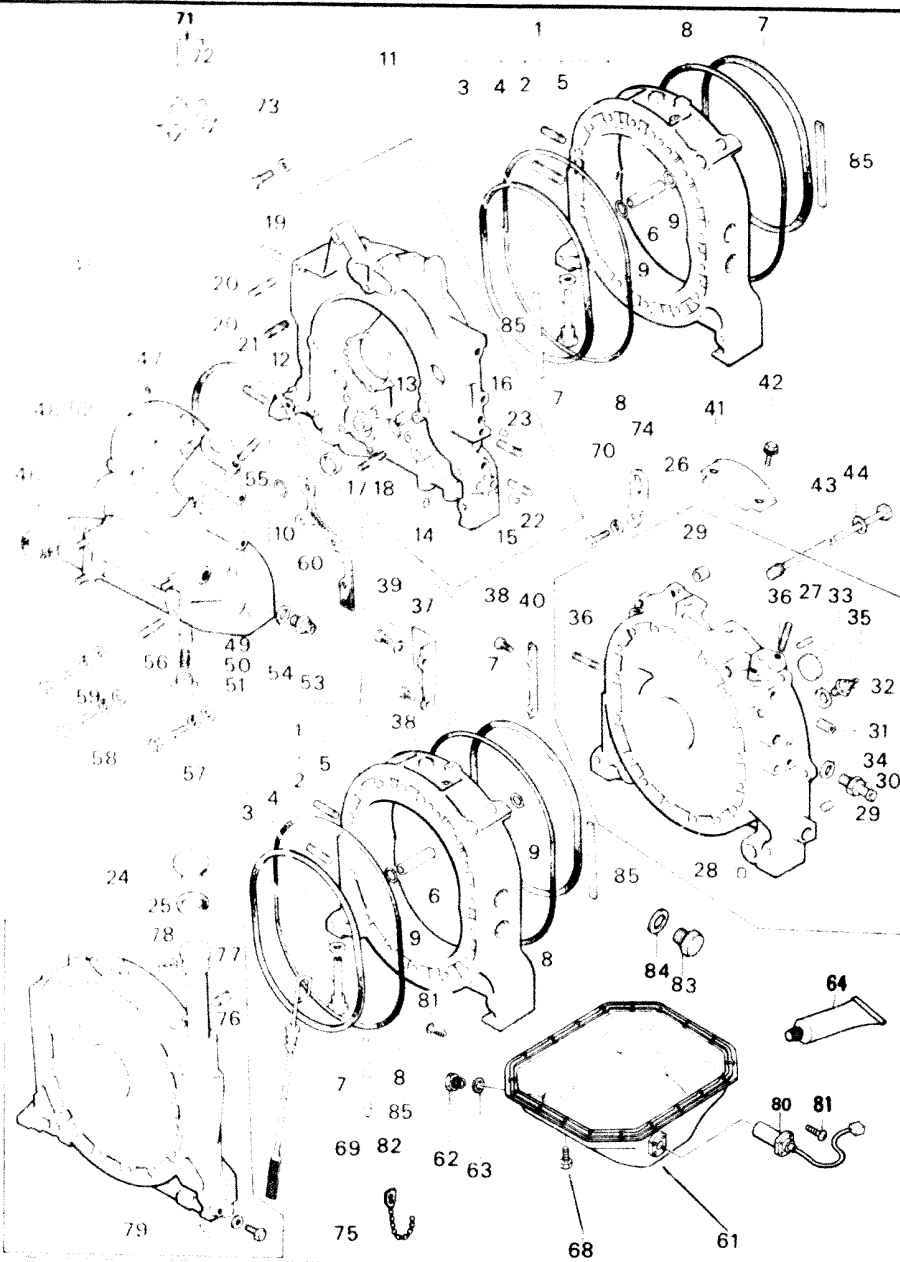

No.	Part Number	Description	Qty	Remarks
63	99562 1400	Gasket	1	
64	8527 77 739	Tube, Silicone	1	For Oil Pan Gasket (100gr)
	1757 10 711	Gasket, Oil Pan	1	
	0839 10 721	Stiffener	2	
	1757 10 722	Stiffener	2	
	1757 10 723	Stiffener	2	
68	99806 0616	Bolt, Oil Pan	22	
	99971 0600	Washer, Spring	22	
69	3565 10 830	Gauge, Oil Level	1	
70	1757 10 845	Bolt, Rear Housing + Engine Hanger	1	
	99971 1000	Washer, Spring	1	
71	3565 10 860 B	Hanger, Engine	1	
72	3565 10 865 B	Clip	1	
73	99801 0820	Bolt, Engine Hanger	1	
	99952 0800	Washer, Plain	1	
	99971 0800	Washer, Spring	1	
74	1757 10 862	Hanger, Engine	1	
75	3648 23 070	Housing, Intermediate (Except Fig. No 76)	1	

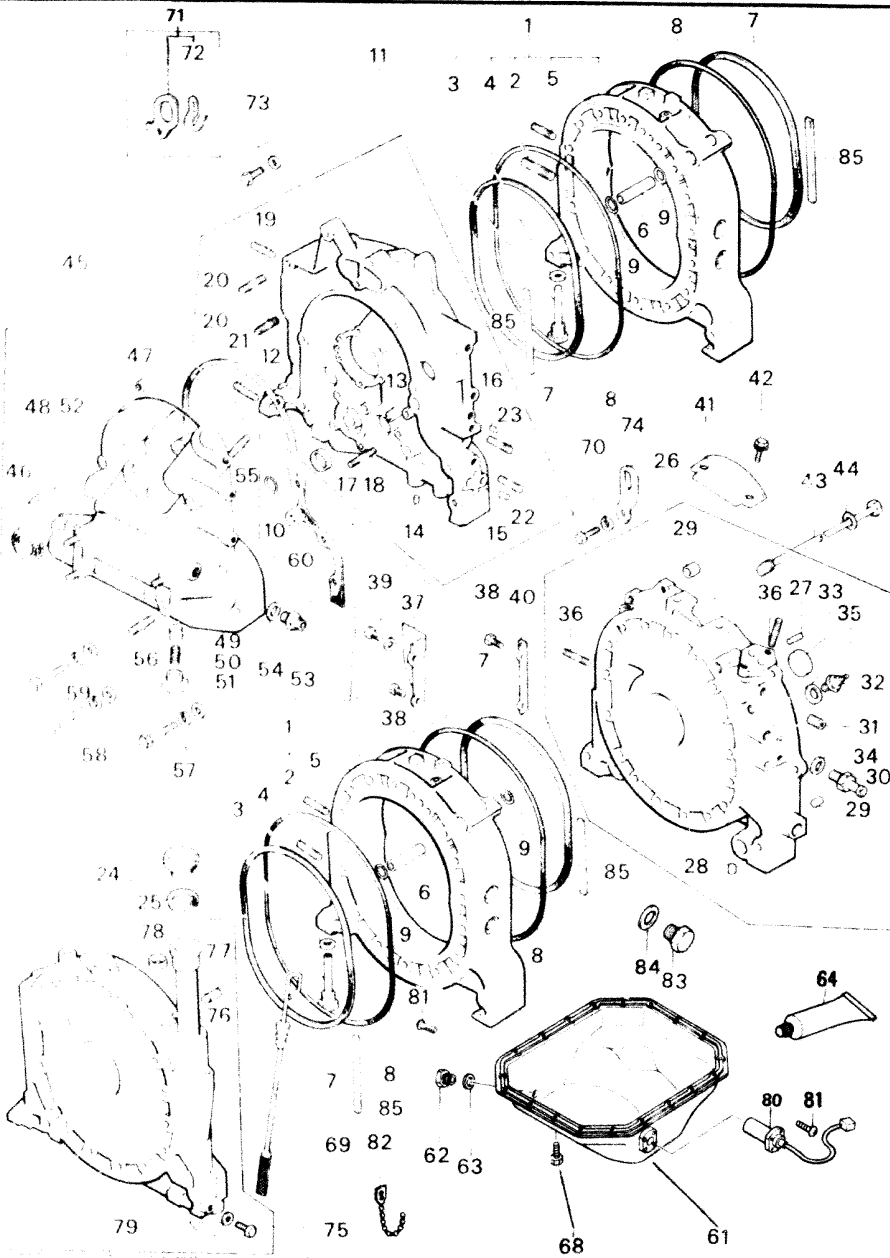

No.	Part Number	Description	Qty	Remarks
76	3565 10 410 A	Pipe, Oil Filler	1	
77	2329 10 417	Joint, Pipe	1	
78	99305 2800	Plug, Expansion	1	
79	99510 1000	Plug	1	
	99564 1000	Gasket	1	
80	3565 10 730 A	Senser, Oil Level	1	
81	99830 0610	Screw, Oil Level Sensor	3	
82	99709 0108	Band (Calif.)	1	
83	99511 1600	Plug	1	(W/O Car Heater)
84	99564 1600	Gasket	1	
85	0866 23 025	Protector	4	
	3790 23 200	Short Engine (Manual)	1	
	3791 23 200	Short Engine (Automatic)	1	
	3565 99 100C	Engine Gasket Set	1	
	1757 23 040A	Ring Set	1	
	1757 23 040B	Ring Set	1	77/6 ~ Δ
	1757 10 171 A	Ring, Square	4	
	1757 10 172	Ring, Square Outer	4	Included in 1757 23 040A

ROTOR HOUSING

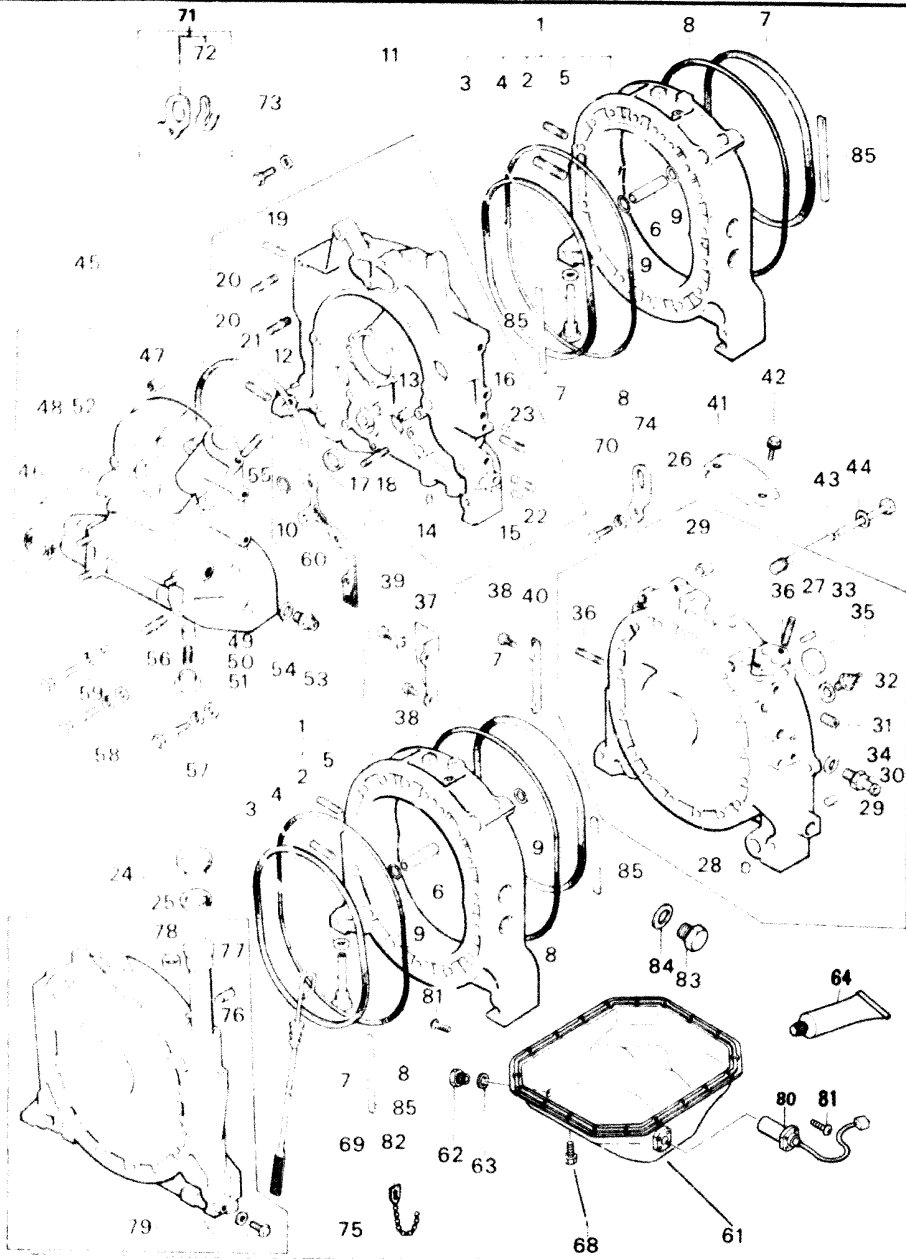

1-11

ROTOR HOUSING

No.	Part Number	Description	Q'ty	Remarks
	0813 10 173	Ring, "O"	4	
	8527 10 174	Ring, "O"	1	
	0839 10 455	Ring, "O"	19	
	0813 10 555	Ring, "O"	1	Included in 1757 23 040A
	99541 01601	Ring, "O"	2	
	99541 02401	Ring, "O"	2	
	99541 0350	Ring, "O"	1	
	8527 10 641	Gasket	1	
	1757 10 711	Gasket	1	
	1757 13 111A	Gasket	1	
	1757 13 221A	Gasket	2	
	3565 13 724	Packing	1	
	1757 13 889B	Gasket	2	
	1757 13 891	Gasket	1	
	1757 15 105A	Gasket	1	
	1757 15 106	Gasket	2	
	0866 23 025	Protector, "O" Ring	4	
	0820 11 341	Ring, "O"	4	
	1202 11 343	Ring, "O"	4	

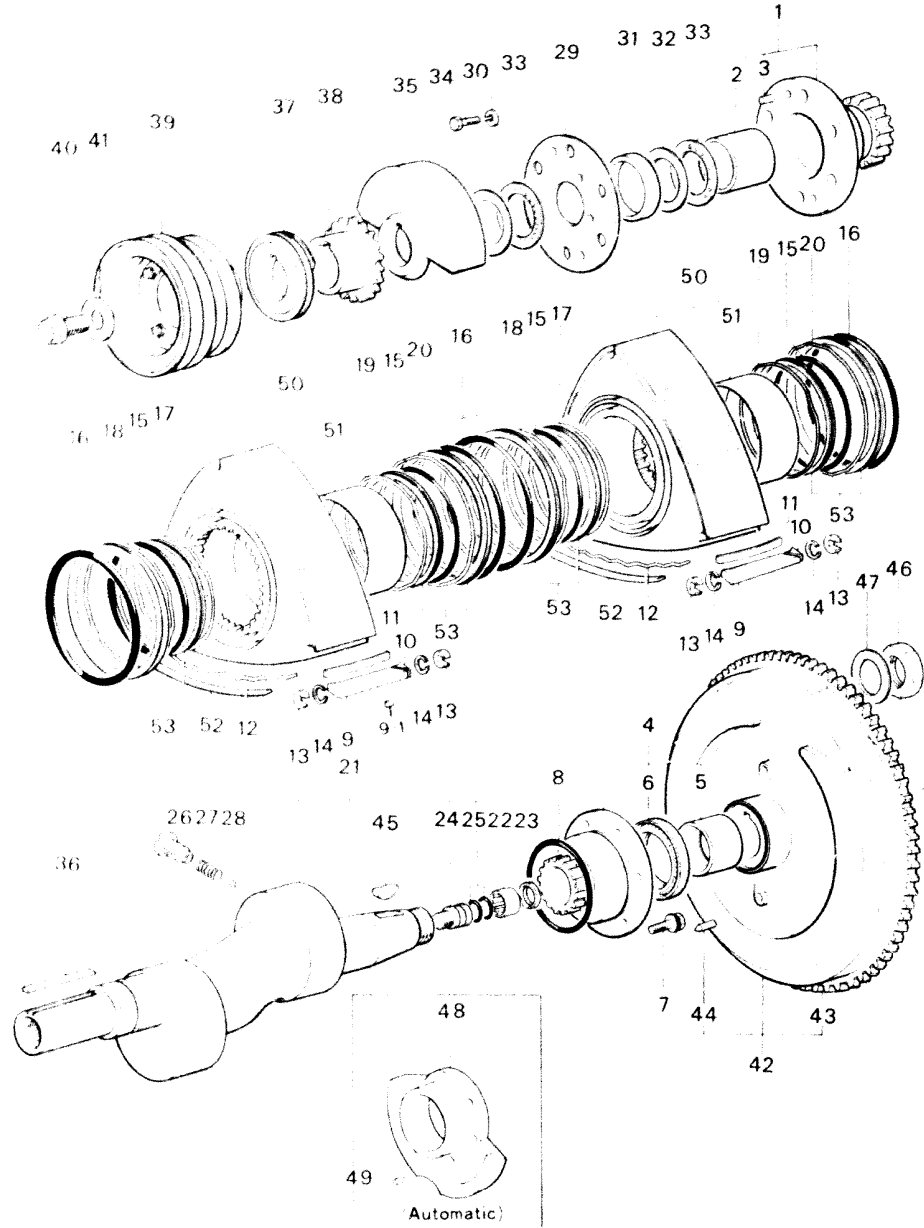

No.	Part Number	Description	Qty	Remarks
1	3648 10 500	Gear (Frt.), Stationary	1	
2	0820 10 502B	Bearing, Main	1	
3	0839 10 504	Pin, Knock	1	
4	3648 10 550	Gear (Rr.), Stationary	1	
5	0820 10 502B	Bearing, Main	1	
6	1668 10 556	Oil Seal	1	
7	99801 0820	Boit, Stationary Gear	6	
	99971 0800	Washer, Spring	6	
8	0813 10 555	Ring, "O" - Stationary Gear	1	
9	1202 11 300A	Seal, Apex	6	
9-1	1056 11 307A	Piece, Assist	6	
10	1202 11 302	Piece, Side	6	
11	1757 11 304	Spring, Apex Seal	6	
12	0820 11 317	Spring, Side Seal	12	
13	1202 11 321	Seal, Corner (Std.)	12	
14	1202 11 323	Spring, Corner Seal	12	
15	0820 11 341	Ring, "O" - Inner	4	
16	1202 11 343	Ring, "O" - Outer	4	

10 **11** ROTOR

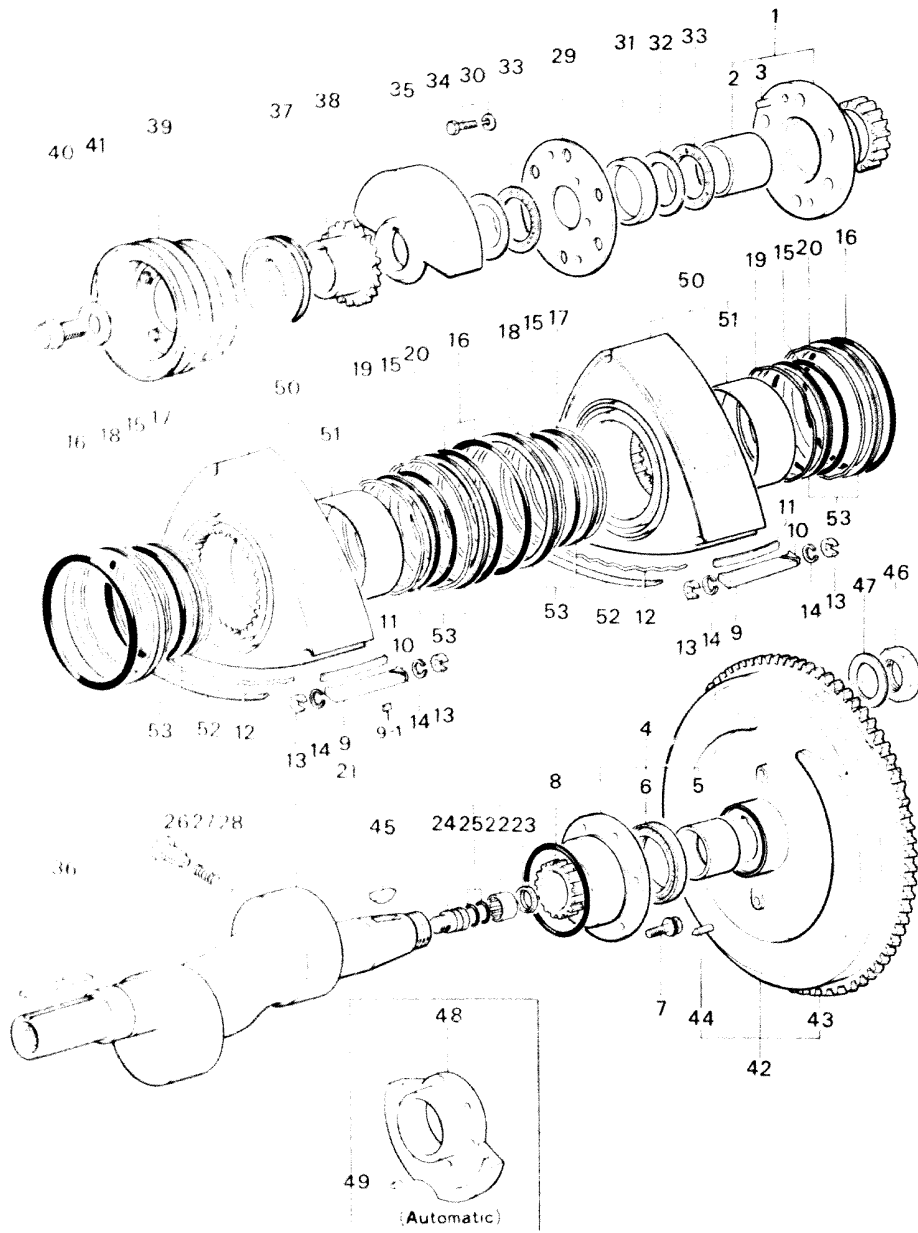

10 **11** ROTOR

No.	Part Number	Description	Qty	Remarks
17	1011 11 351	Spring, Oil Seal Inner (Frt)	2	
18	1011 11 353A	Spring, Oil Seal Outer (Frt)	2	
19	1011 11 361	Spring, Oil Seal Inner (Rr)	2	
20	1011 11 363A	Spring, Oil Seal Outer (Rr)	2	
21	3648 11 400	Shaft, Eccentric Manual	1	
	8501 11 400	Shaft, Eccentric Automatic	1	
22	1881 11 403	Bearing, Needle	1	Manual
23	1881 11 404	Oil Seal	1	
24	0813 11 405	Plug, Blind	1	
25	99541 01101	Ring, "O"	2	
26	0839 11 411A	Plug, Oil Jet	2	
27	0839 11 412	Spring	2	
28	99611 2000	Ball, Steel	2	
29	1011 11 501	Plate	1	
30	99801 0825	Bolt, Plate & Stationary Gear	6	
	99971 0800	Washer, Spring	6	
31	0839 11 502	Spacer (L. 8.02)	1	Selective use
	0839 11 506	Spacer (L. 8.08)	1	

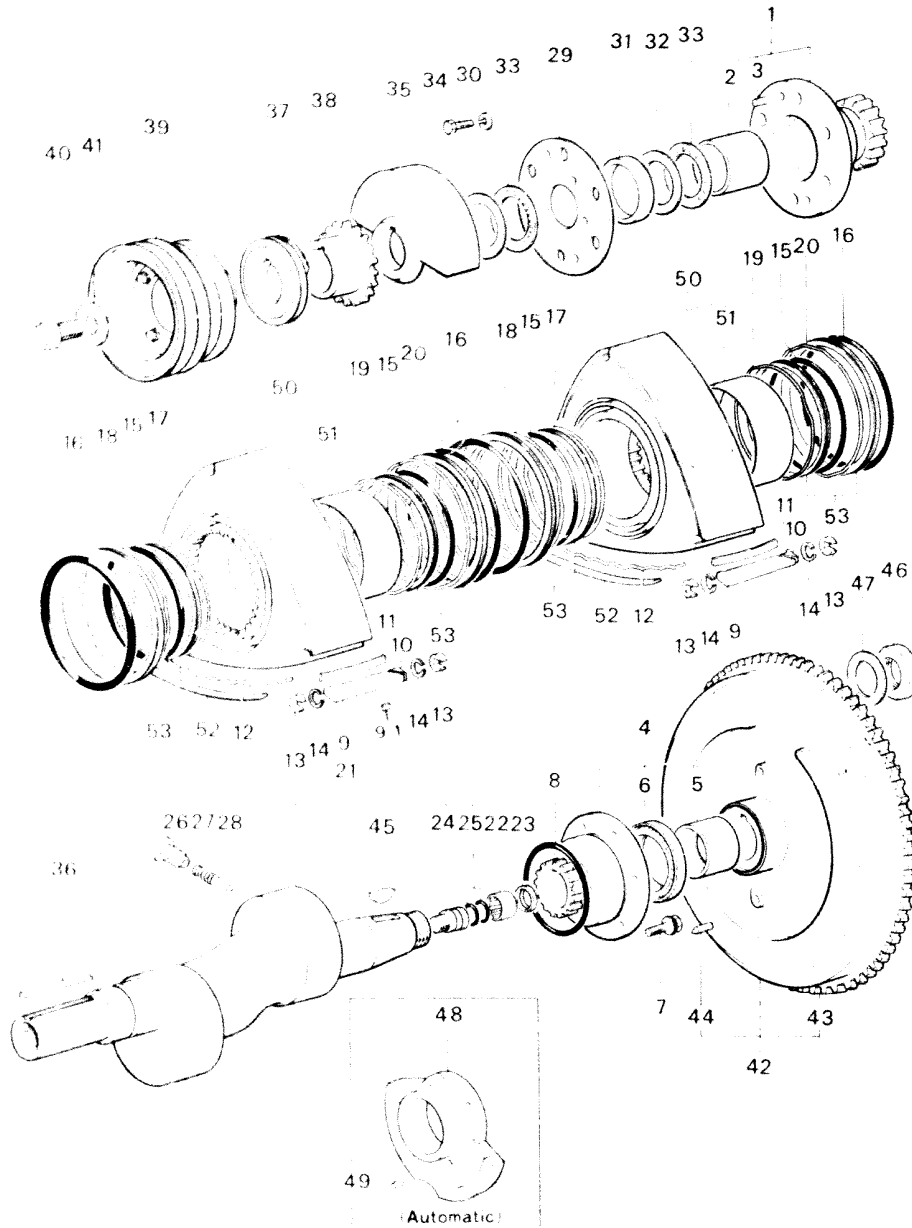

No.	Part Number	Description	Q'ty	Remarks
	0839 11 508	Spacer (L=8.04)	1	Selective use
	0839 11 509	Spacer (L=8.00)		
32	1011 11 504	Plate, Thrust	1	
33	0813 11 505B	Bearing, Needle	2	
34	1011 11 507	Washer, Thrust	1	
35	1757 11 511	Weight, Balance (Automatic)	1	
	1854 11 511	Weight, Balance (Manual)	1	
36	99236 0571	Key	1	
37	0839 11 531	Gear, Drive-Distributor	1	
38	0839 11 551A	Gear, Drive-Oil Pump	1	
39	3790 11 600	Pulley	1	
40	0820 11 611B	Bolt, Pulley	1	
41	99562 2800	Gasket, Bolt	1	
42	1854 11 700	Wheel, Fly	1	
43	0866 11 702	Gear, Ping (Manual)	1	
44	99222 0610	Pin	1	
45	0820 11 705	Key, Fly Wheel	1	

10 **11** ROTOR

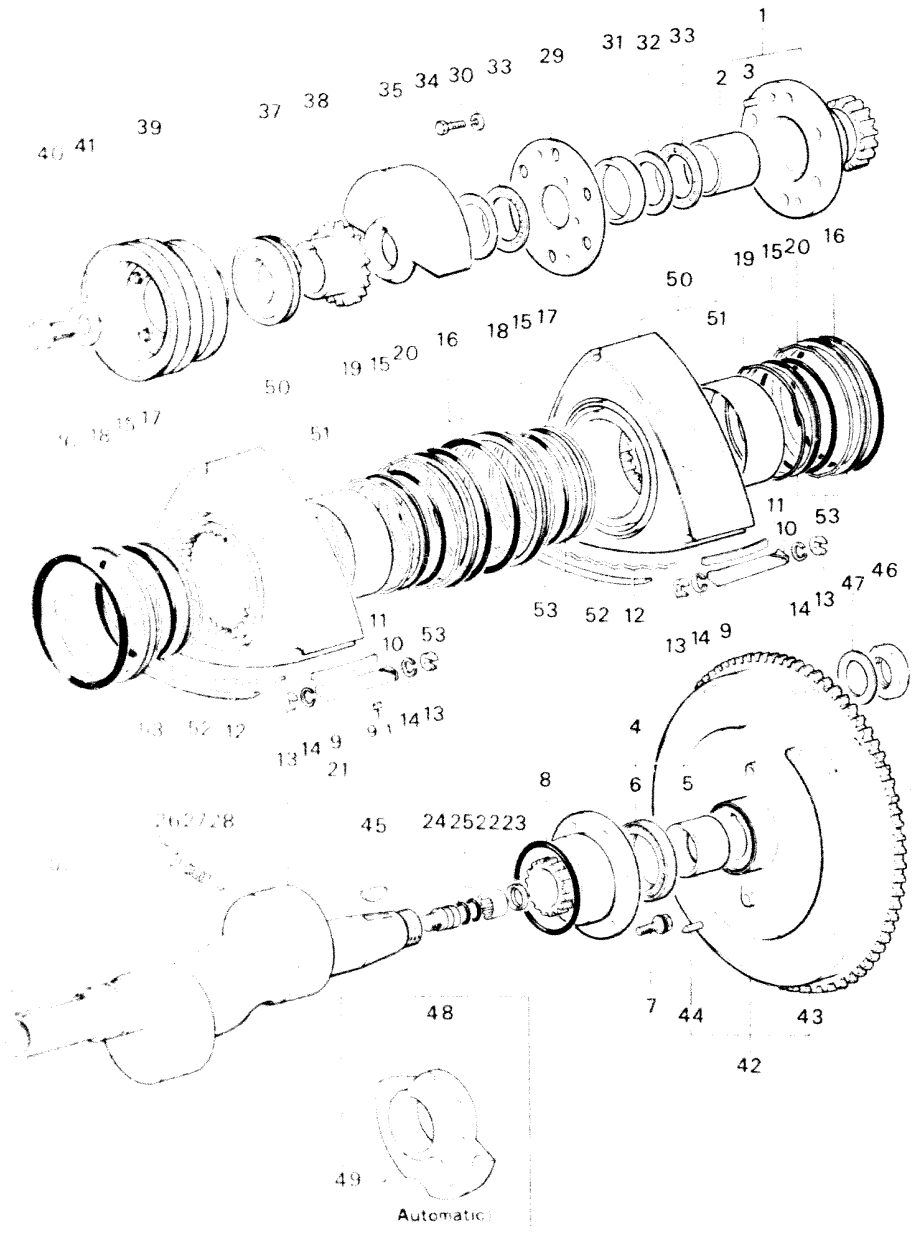

10 **11** ROTOR

No.	Part Number	Description	Q'ty	Remarks
46	0810 11 711	Nut, Lock	1	
47	0820 11 712	Washer, Lock	1	
48	1029 11 750	Weight, Counter	1	(Automatic)
49	99222 0610	Pir.	1	
50	1757 23 103	Rotor "C"	2	
51	1011 11 111	Bearing, Rotor	2	
52	1011 23 151A	Seal, Side	12	
53	8735 23 180	Oil Seal Set	1	

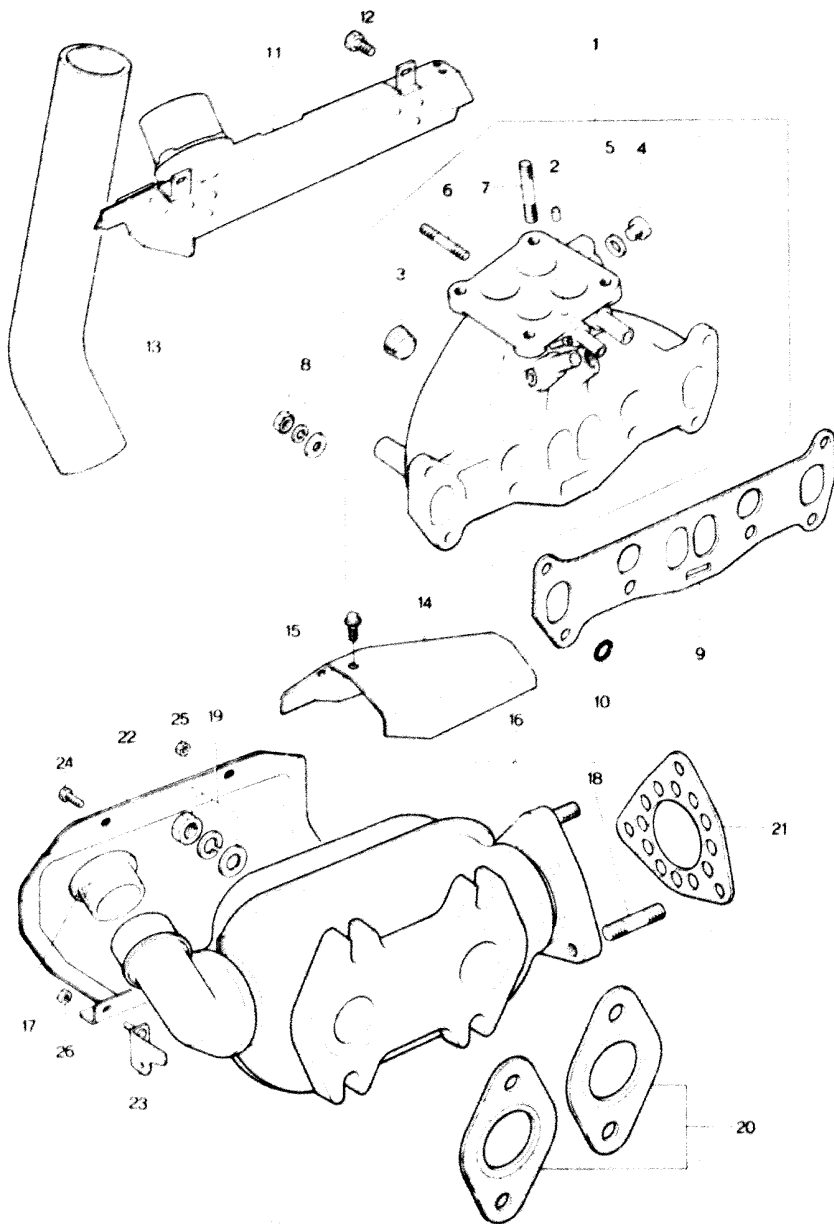

No.	Part Number	Description	Q'ty	Remarks
1	3565 13 100C	Manifold, IN	1	
2	99307 0600	Plug, Blind	1	
	99307 0800	Plug, Blind	1	(Except Calif.)
	99307 1000	Plug, Blind	1	
3	99503 3000	Plug	2	
4	99511 1000	Plug	1	
5	99564 1000	Gasket	1	
6	99851 0622A	Stud, Control Valve	3	
7	99851 0832A	Stud, Carburettor	4	
8	99940 0801	Nut, IN Manifold	6	
9	1757 13 111A	Gasket, IN Manifold	1	
10	99541 2401	Ring, "O" - IN Manifold	2	
11	3565 13 330A	Duct, Hot Air	1	
12	99796 0812	Bolt, Hot Air Duct	2	
13	1757 13 341A	Hose, Hot Air	1	
14	1757 13 371B	Insulator, Heat	1	
15	99786 0616	Bolt, Heat Insulator	2	
	99952 0600	Washer, Plain	2	

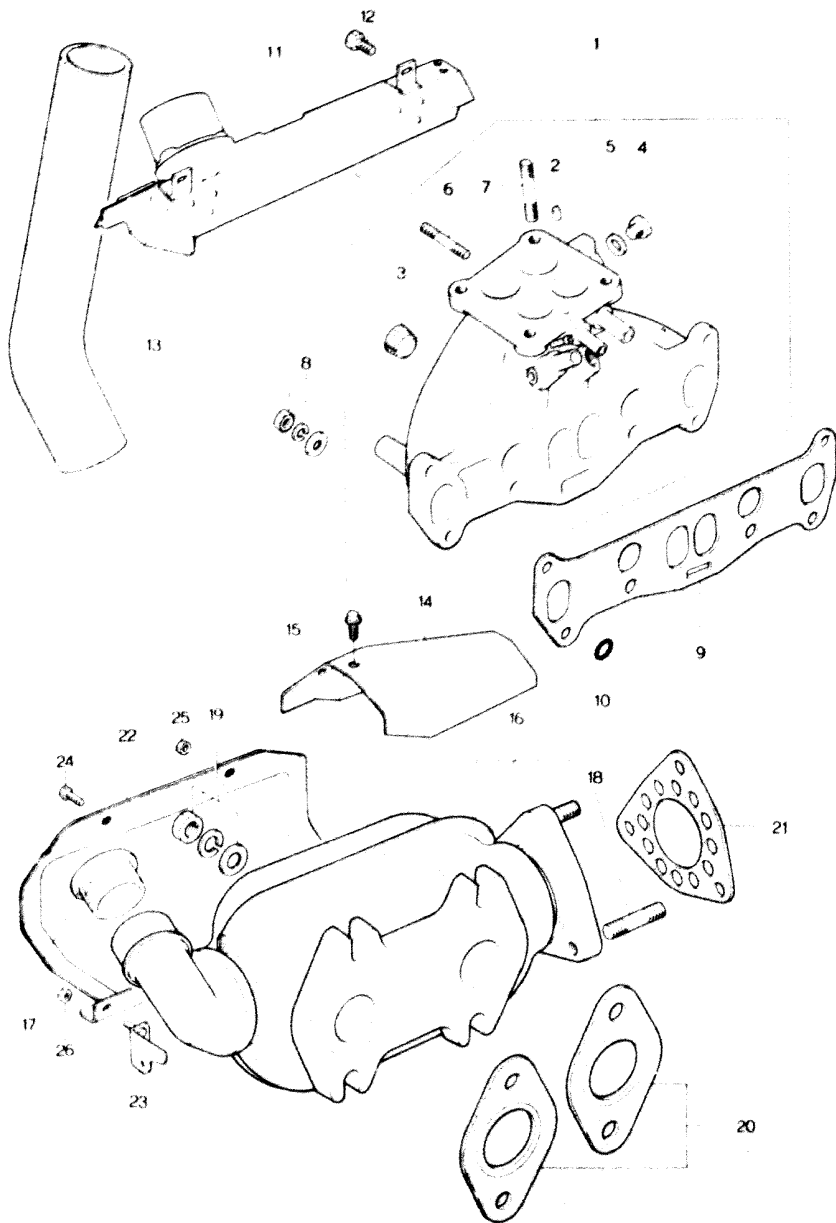

No.	Part Number	Description	Qty	Remarks
16	3567 13 800A	Reactor, Thermal	1	
17	2090 13 742B	Insert	1	
18	2329 13 876	Stud	3	
19	2158 40 355	Nut, Thermal Reactor	4	
	0839 13 614	Washer, Plain	4	
	2329 13 882	Washer, Spring	4	
20	1757 13 889B	Gasket, Thermal Reactor	2	
21	1757 13 891	Gasket, Thermal Reactor	1	
22	3565 13 380B	Plate, Absorber	1	
23	3565 13 390	Bracket	1	
24	99796 0812	Bolt, Absorber Plate	1	
25	99940 0600	Nut, Absorber Plate	2	
26	99940 0800	Nut, Bracket	1	

FAST IDLING KIT & EMISSION CONTROL SYSTEM



FAST IDLING KIT & EMISSION CONTROL SYSTEM

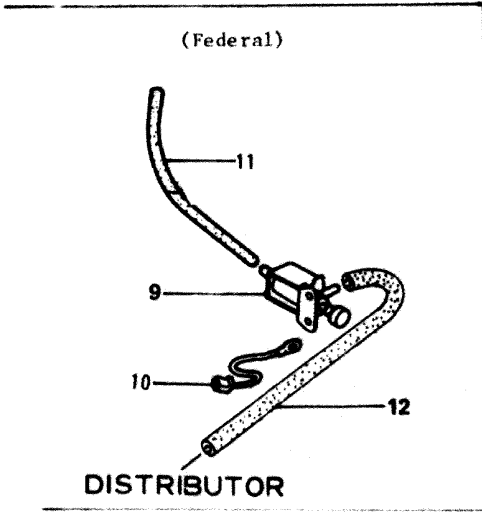
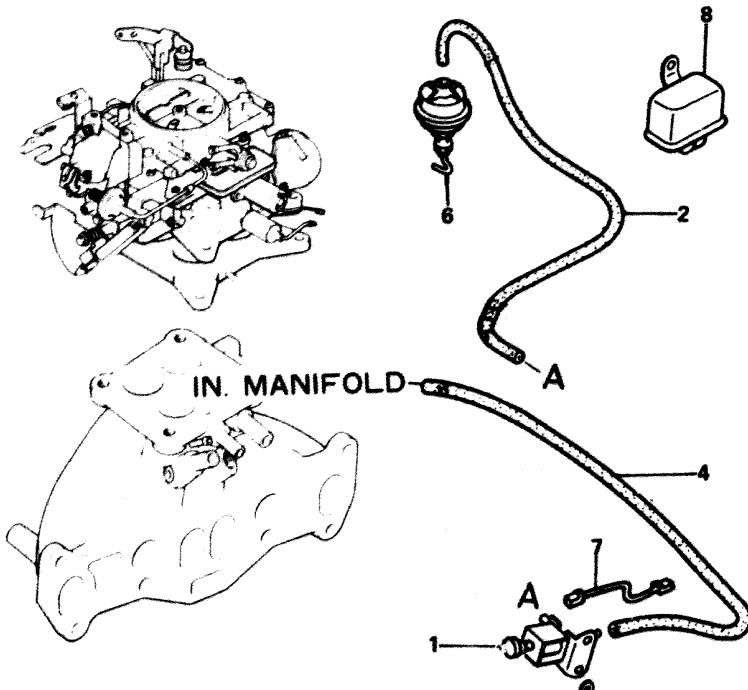

No.	Part Number	Description	Qty	Remarks
-----	-------------	-------------	-----	---------

1	3597 13 240	Valve, 3 Way	1	
•	3597 13 240A	Valve, 3 Way	1	77/3 ~ Δ
2	8501 13 296D	Hose, Air	1	
3	3597 18 862	Cord, Earth	1	
4	99340 04270	Hose	1	
5	99796 0812	Bolt	2	
6	3648 13 290	Actuator	1	
7	3597 13 863	Cord	1	
8	1016 67 620	Relay	1	
9	8735 13 240	Valve, 3 Way	1	
•	8735 13 240A	Valve, 3 Way	1	77/3 ~ Δ
10	3597 18 862	Cord, Earth	1	
		(Federal)		
11	99340 04130	Hose	1	
12	99340 04270	Hose	1	

No.	Part Number	Description	Q'ty	Remarks
1	3648 13 300B	Cleaner, Air	1	
2	1757 13 351A	Hose, Air	1	
3	1757 23 672	Element	1	
4	3648 23 673	Cover, With Charcoal Filter (BLU)	1	
5	1757 23 680	Gasket Set	1	
6	3648 23 693A	Compensator	1	
7	1617 13 305A	Clip	1	
8	3648 13 310A	Support, Air Cleaner	1	
9	99940 0802	Nut, Air Cleaner	2	
10	99786 0816	Bolt, Air Cleaner Support	1	
	99952 0822	Washer, Plain	1	
11	99941 0801	Nut, Wing-Air Cleaner	1	

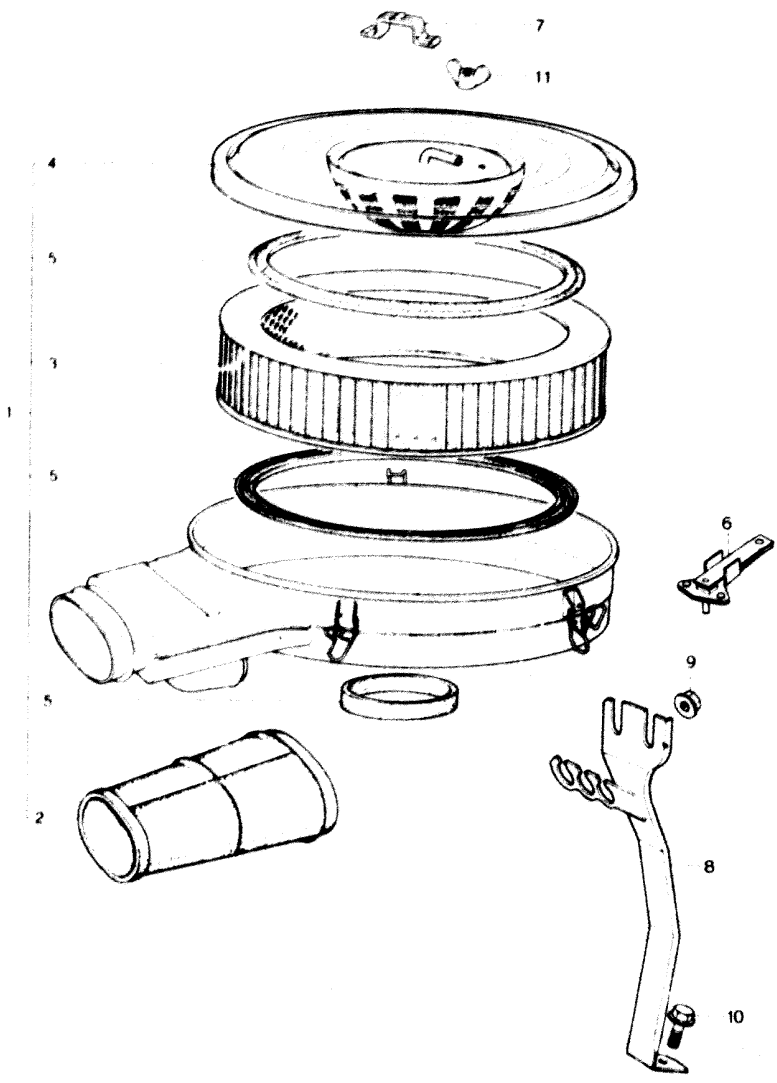

STARTING ASSIST SYSTEM

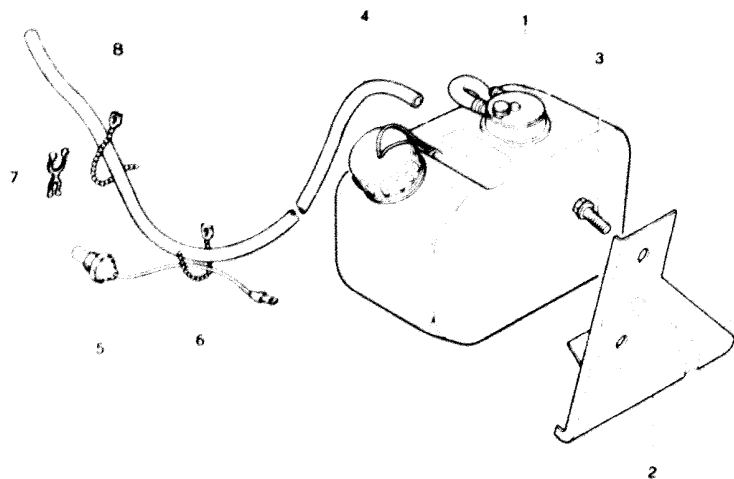

STARTING ASSIST SYSTEM

No.	Part Number	Description	Q'ty	Remarks
1	1757 13 510B	Tank, Starting Fluid	1	
2	1881 13 515A	Bracket, Tank	1	
3	99786 0612	Screw, Tank Bracket	2	
4	1757 13 527B	Hose	(Federal) 1	
5	8712 13 531	Unit, Thermo	1	
6	99709 0108	Band	1	
7	99288 0808B	Clip	1	
8	99709 0255	Band	1	

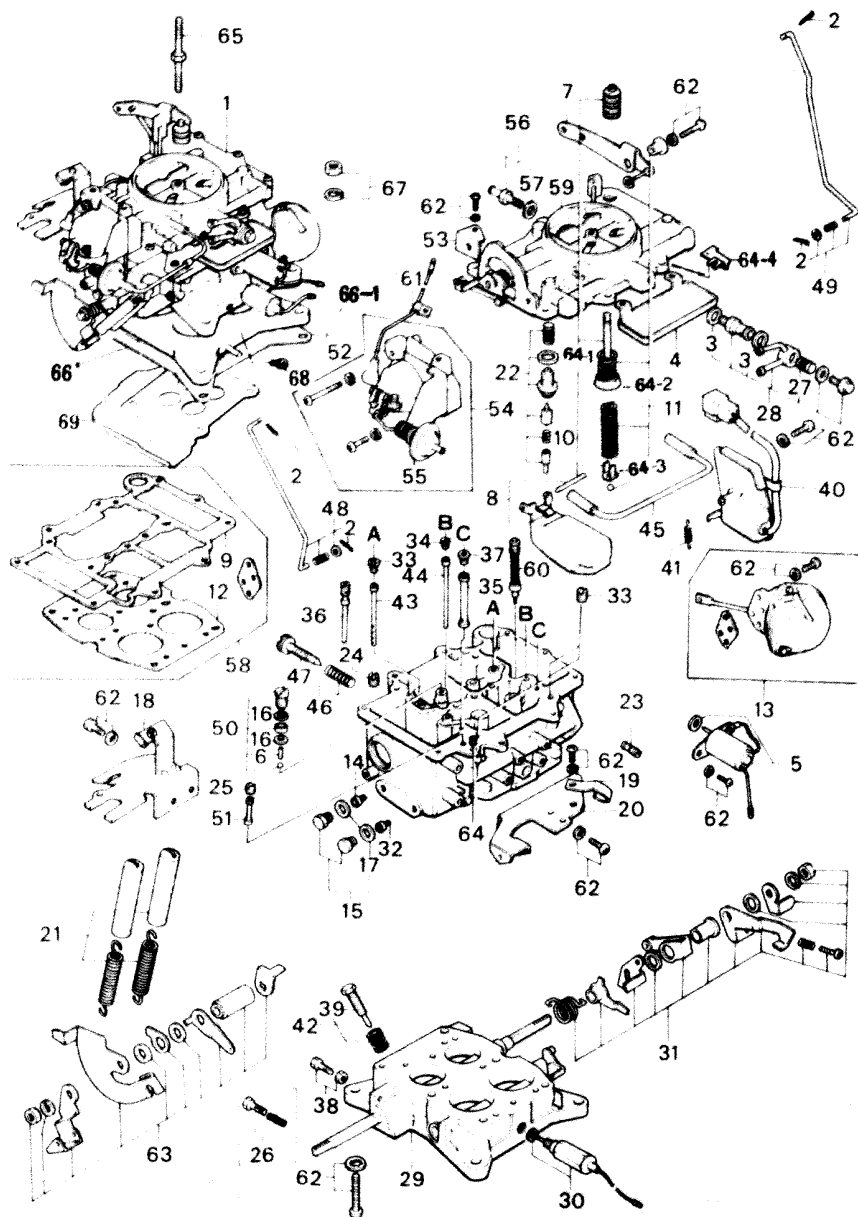

No.	Part Number	Description	Q'ty	Remarks
1	3787 13 200	Carburettor (Manual)	1	
	3789 13 200	Carburettor (Automatic)	1	
2	0136 13 717A	Pin, Cotter	6	
3	0114 13 788A	Washer	3	
4	8503 23 318	Tray-Fuel	1	
5	3567 23 322	Valve Kit, Power (Automatic)	1	
6	3648 23 324	Weight, 1.6	1	
7	3565 23 325	Lever, Pump	1	
8	3565 23 326	Float Set	2	
9	3565 23 327	Gasket, Float Chamber	1	
10	3787 23 331	Pump Sub Ass'y "A"	1	
11	3565 23 332	Pump Sub Ass'y "B"	1	
12	3565 23 349	Gasket, Throttle Chamber	1	
13	8527 23 350	Chamber Set, DIAPH.	1	
14	3787 23 353	Jet, Main-Primary	2	
15	3565 23 354	Plug Set, Drain	4	
16	0187 23 356	Washer-7	2	
17	0291 23 366	Washer-9	4	
18	3648 23 370	Bracket, Throttle Wire	1	
19	8501 23 374	Clip, Vacuum Pipe	1	

13 23 CARBURETTOR

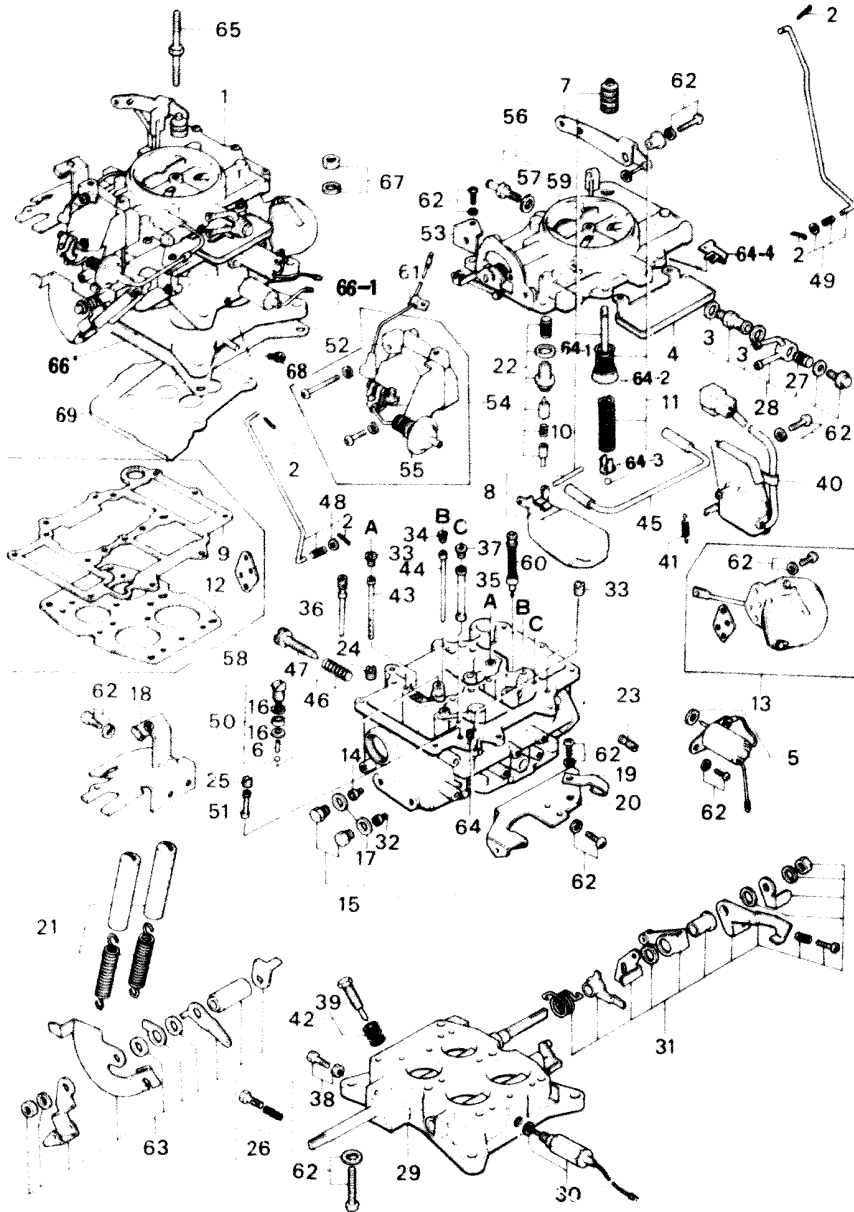

13 23 CARBURETTOR

No.	Part Number	Description	Q'ty	Remarks
20	3648 23 375	Bracket	1	
21	8712 23 380	Spring Set, Return	2	
22	8504 23 390	Valve Set, Needle	2	
23	8712 23 393	Jet, Vacuum	1	
24	3565 23 394	Jet, Slow Air Bleed Primary	2	
25	1208 23 395	Jet, Richer Air Bleed No. 1 (Manual)	1	
26	3775 23 397	Screw, Throttle Adjust (Calif.)	1	
27	8503 23 401	Filter	2	
28	3787 23 409	Connector Set, Fuel	1	
29	3787 23 410	Flange Set (Manual)	1	
	3789 23 410	Flange Set (Automatic)	1	
30	1029 23 411	Solenoid Set (Manual)	1	
31	8712 23 420	Lever Set, Front	1	
32	8712 23 422	Jet, Main-Secondary	2	
33	3585 23 423	Jet, Main Air Bleed Primary	4	
34	3626 23 424	Jet, Main Air Bleed Secondary	2	
35	3565 23 426	Jet, Slow-Secondary	2	
36	3565 23 427	Jet, Slow-Primary	2	
37	3565 23 428	Jet, Slow-Air Bleed-Secondary No. 1	2	
38	8501 23 440	Screw Set, Throttle Adjust	1	

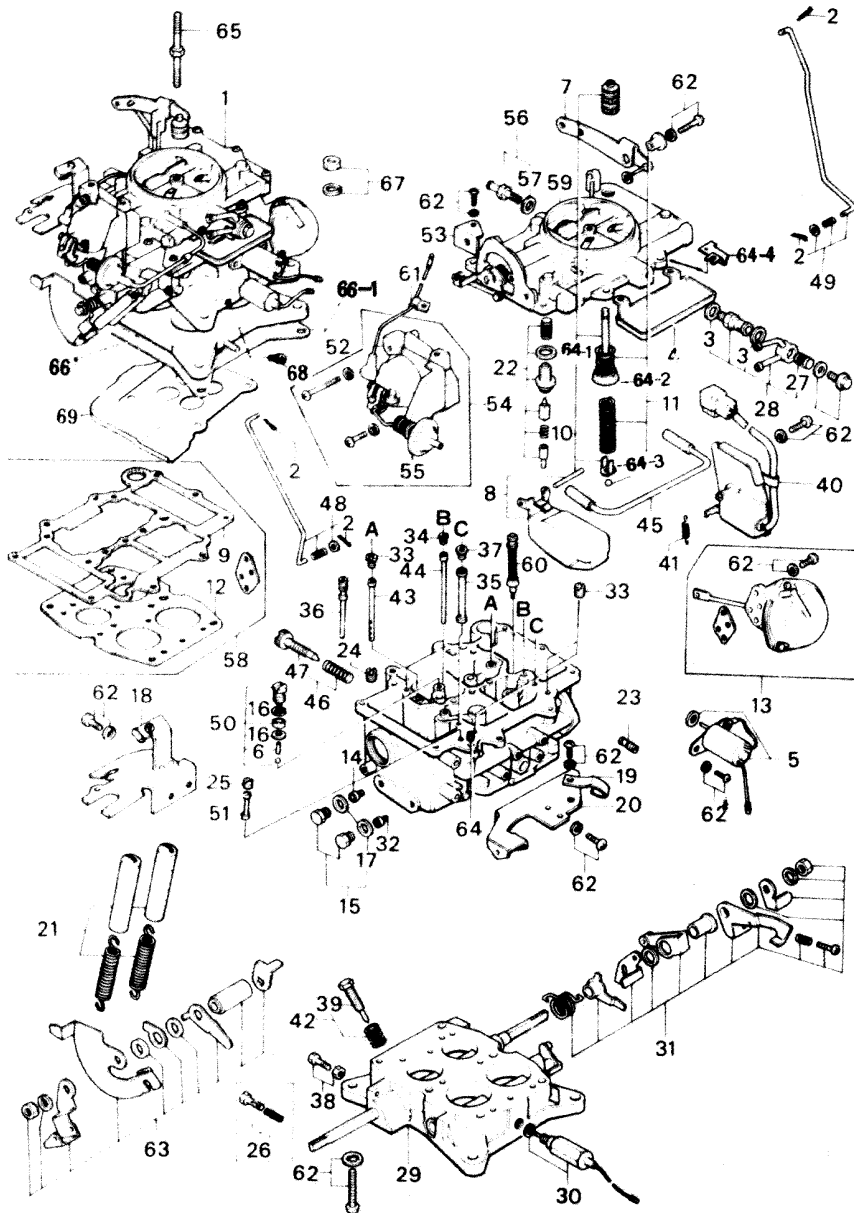

No.	Part Number	Description	Q'ty	Remarks
39	3565 23 446	Screw, Idle Adjust (Automatic)	1	
	3787 23 446	Screw, Idle Adjust (Manual)	1	
40	1757 23 450	Switch, Set, Idle	1	
41	1757 23 455	Spring	1	
42	3565 23 460	Screw Set, Idle Adjust (Automatic)	1	
	3787 23 460	Screw Set, Idle Adjust (Manual)	1	
43	3787 23 461	Tube, Emulsion (P)	2	
44	3565 23 462	Tube, Emulsion (S)	2	
45	3565 23 464	Pipe, Rubber	1	
46	1757 23 470	Screw Set, Air Adjust	1	
47	3900 23 471	Screw, Air Adjust	1	
48	1029 23 480	Rod Set, Choke	1	
49	1757 23 481	Rod Set, Accel	1	
50	3565 23 490	Nozzle Set, Accel	1	
51	8501 23 491	Jet, Richer	1	
52	3565 23 495	Holder, Pipe Clip	1	
53	3565 23 496	Stopper, Choke Rod	1	
54	3787 23 500	Choke Set, Semi Auto	1	
55	3565 23 501	Piston, Choke	1	
56	1757 23 507	Valve Set, Check	1	

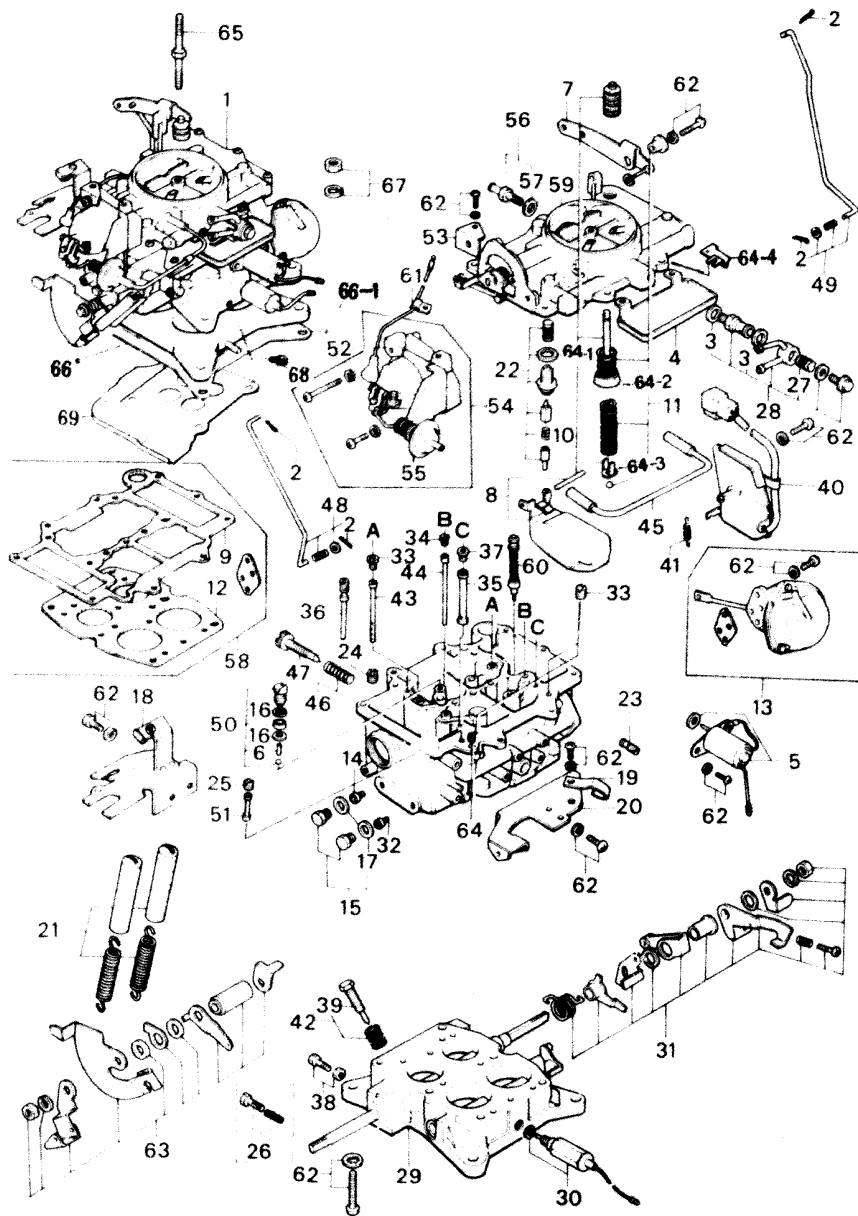

No.	Part Number	Description	Qty	Remarks
57	3565 23 508	Washer-10	1	
58	3787 23 510	Gasket Set	1	
59	3787 23 520	Horn Set, Air	1	
60	3567 23 541	Jet, Power Valve (Automatic)	2	
61	3565 23 549	Stopper, Lead Wire	1	
62	3565 23 652	Screw & Washer Set	1	
63	8712 23 430	Lever Set, Rear	1	
64	1757 23 433	Jet, Slow Air Breed-Secondary No. 2	1	(Manual)
64-1	8527 23 519	Washer	2	
64-2	3787 23 323	Piston, Accel Pump	1	
64-3	3648 23 337	Piece, Distance	1	
64-4	8712 23 319	Stopper, Connector	1	
65	1757 13 201A	Bolt, Cleaner Set	1	
66	8712 13 220A	Insulator, Carburettor	1	
66-1	1757 13 221A	Gasket, Carburettor	1	
67	99901 0800	Nut, Carburettor	4	
	99971 0800	Washer, Spring	4	
68	8527 13 205	Cap, Idle Limiter	1	
69	8712 13 231A	Tray, Carburettor	1	

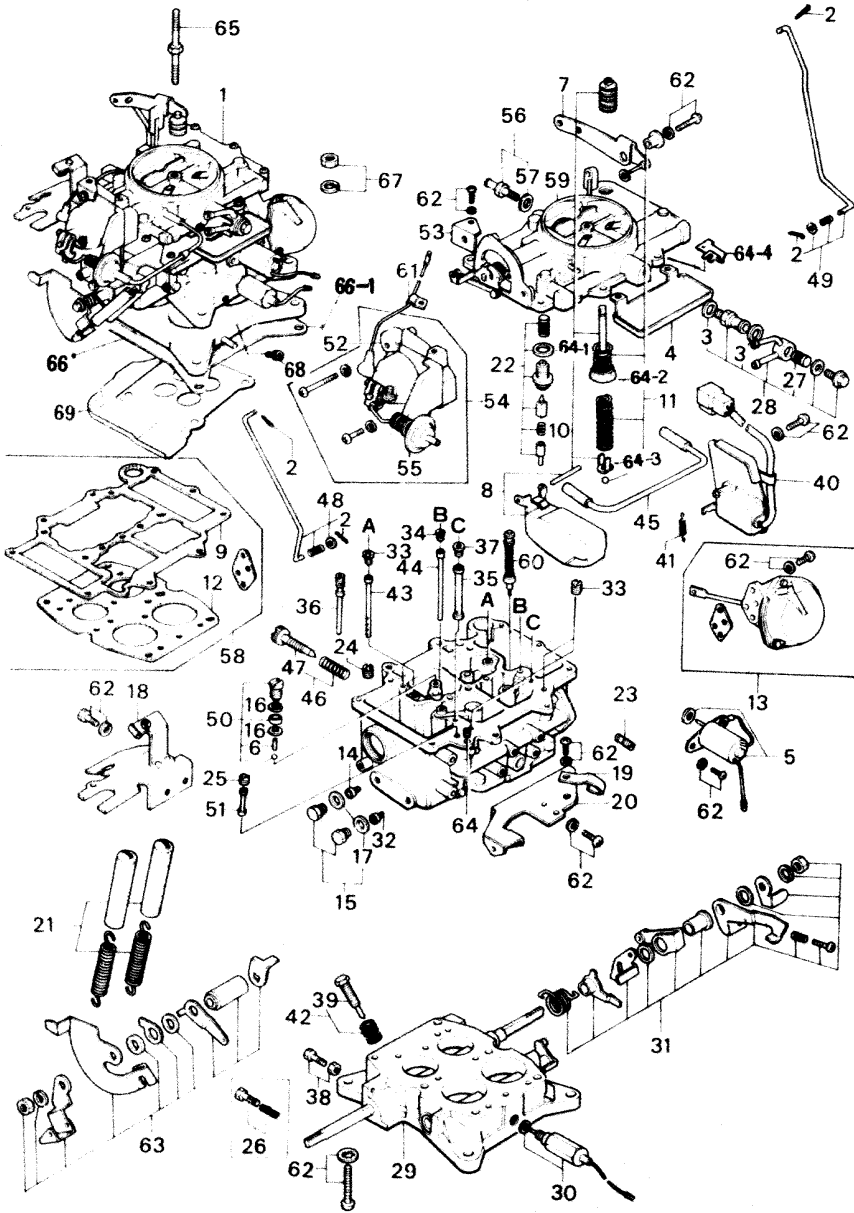

No. Part Number	Description	Q'ty	Remarks
3787 23 540	Repairkit, Carburettor (Fig No. 2, 10, 11, 22 & 58 included)	1	
3788 23 522	Label, High Attitude (Fed. Manual)	1	

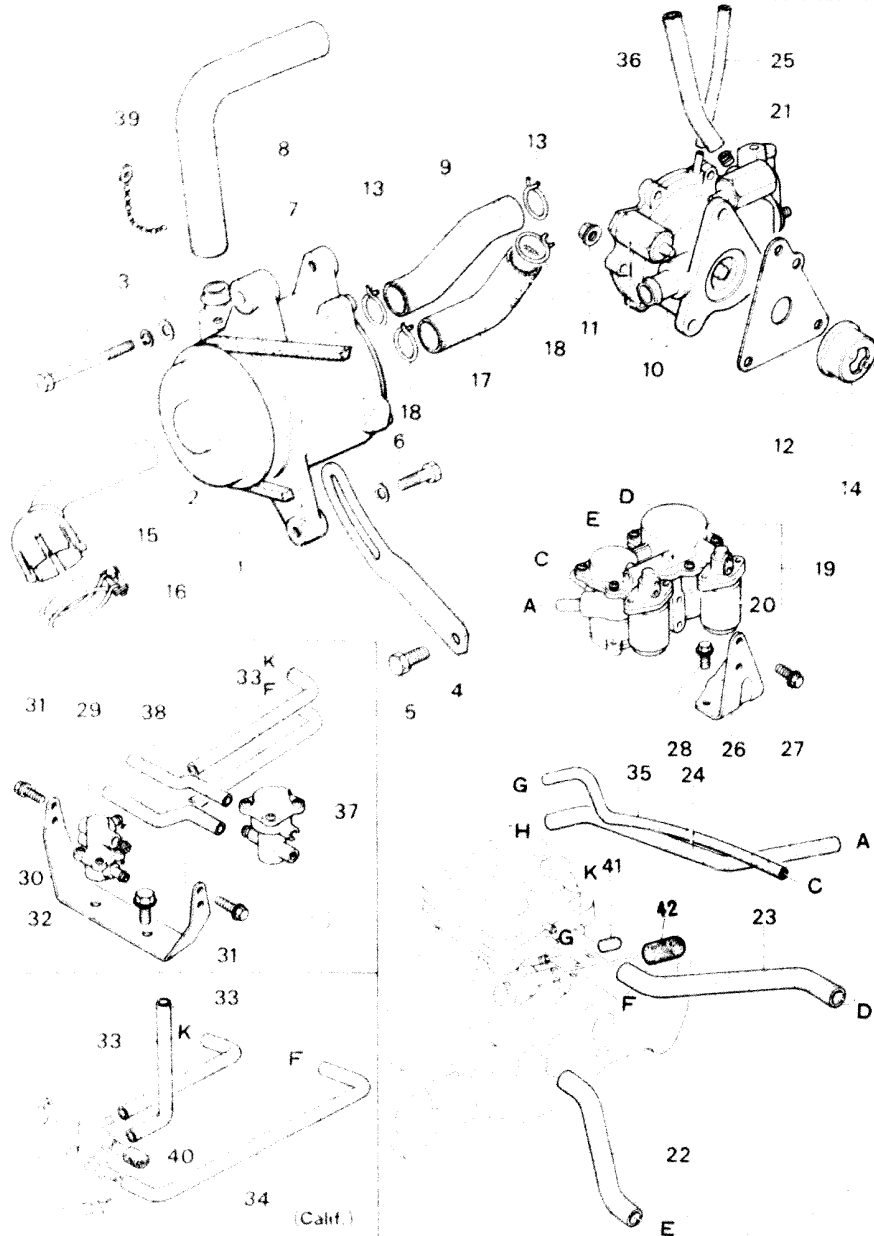

No.	Part Number	Description	Qty	Remarks
1	1757 13 710A	Pump, Air	1	
2	1757 23 713	Pulley, Air Pump	1	
3	99803 08100	Bolt, Air Pump	1	
	99952 0800	Washer, Plain	1	
	99971 0800	Washer, Spring	1	
4	1757 13 714	Strap, Air Pump	1	
5	99796 0814	Bolt, Strap	1	
6	90796 0E20	Bolt, Strap	1	
7	1757 13 715	Belt, "V"-Air Pump	1	
8	1757 13 717	Hose, Air-Air Pump ~ Air Cleaner	1	
9	3565 13 718	Hose, Air-A.C. Valve ~ Air Pump	1	
10	8712 13 720	Valve, Air Control	1	
11	99940 0601	Nut, Air Control Valve	3	
12	3790 13 724	Gasket, A.C. Valve	1	
13	2329 13 726	Clip, Air Hose	7	
14	3790 13 730	Valve, Check	1	
15	8501 13 740	Pipe, Air-Reactor Side	1	
16	99282 4309	Band, Hose-Air Pipe	1	
17	1757 13 744	Hose, Air-Reactor ~ A.C. Valve	1	

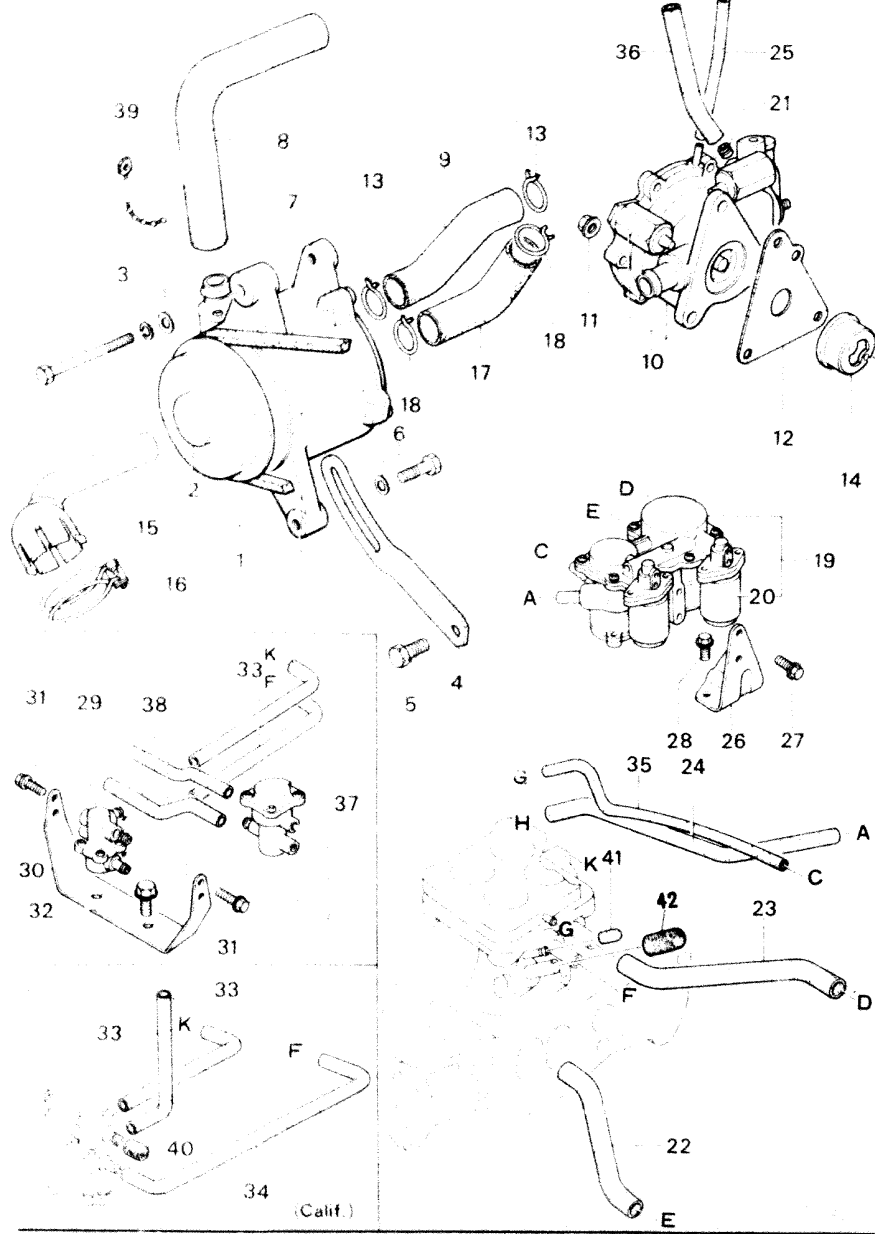

No.	Part Number	Description	Q'ty	Remarks
18	2090 13 746	Clip, Air Hose	2	
19	1757 13 750	Valve, Deceleration Control (Manual)	1	
	8715 13 750	Valve, Deceleration Control (Automatic)	1	
20	1757 23 725	Valve, Solenoid	3	
21	3790 13 759A	Insert (Manual)	1	
	3648 13 759	Insert (Automatic)	1	
22	8712 13 752	Hose, Air-D.C. Valve ~ Air Cleaner	1	
23	1757 13 753C	Hose, Air-D.C. Valve ~ IN. Manifold	1	
24	8735 13 754	Hose, Air-D.C. Valve ~ IN. Manifold	1	
25	3648 13 725	Hose, Air-A.C. Valve ~ Air Cleaner	1	
26	8712 13 757	Supporter, D.C. Valve	1	
27	99796 0610	Bolt, Supporter + D.C. Valve	2	
28	99796 0812	Bolt, D.C. Valve Supporter	2	
29	1757 13 770B	Compensator, Altitude	1	
30	8735 13 772B	Bracket (Fed.)	1	
31	99796 0610	Bolt, Alti. Compensator	4	
32	99796 0812	Bolt, Bracket	2	
33	1757 13 775A	Hose, Air-Alt.	2	
		Compensator & IN. Manifold		

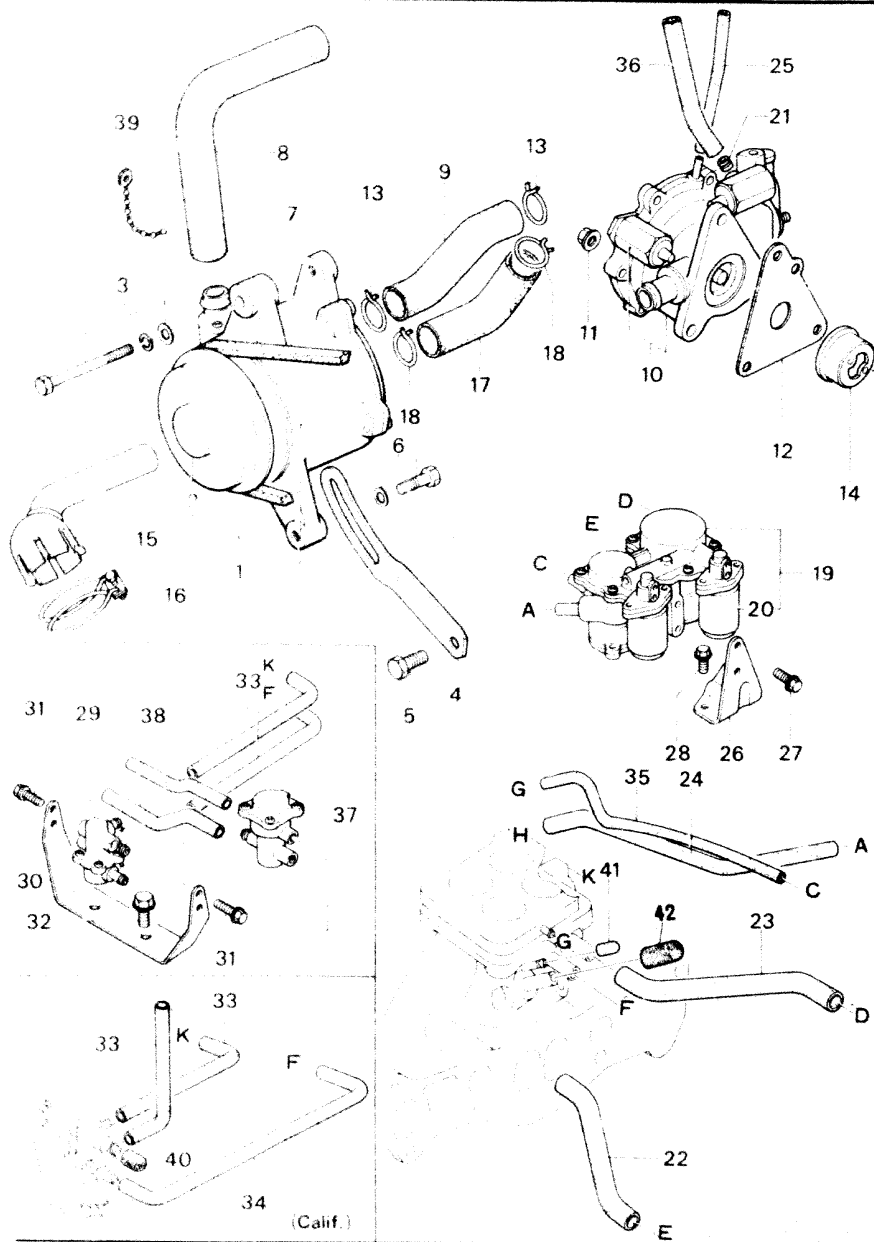

No.	Part Number	Description	Qty	Remarks
34	99340 06230	Hose, Air-Alti. Compensator ~ IN. Manifold	1	
35	99340 04200	Hose, Air-D.C. Valve ~ IN. Manifold	1	
36	99340 04200	Hose, Air-A.C. Valve ~ Air Cleaner	1	
37	1757 13 910	Valve, Emission Control (Except Calif.)	1	
38	1757 13 912A	Hose, Air-Alti. Compensator ~ E.C. Valve (Except Calif.)	2	
39	99709 0255	Band	1	
40	2306 10 481	Cap, Evaporation (Calif.)	1	
41	1010 13 104	Cap, IN. Manifold	1	
42	8712 13 104	Cap, IN. Manifold (Automatic)	2	

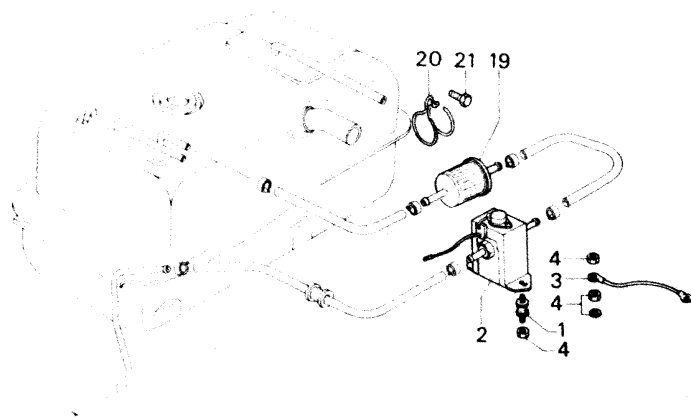
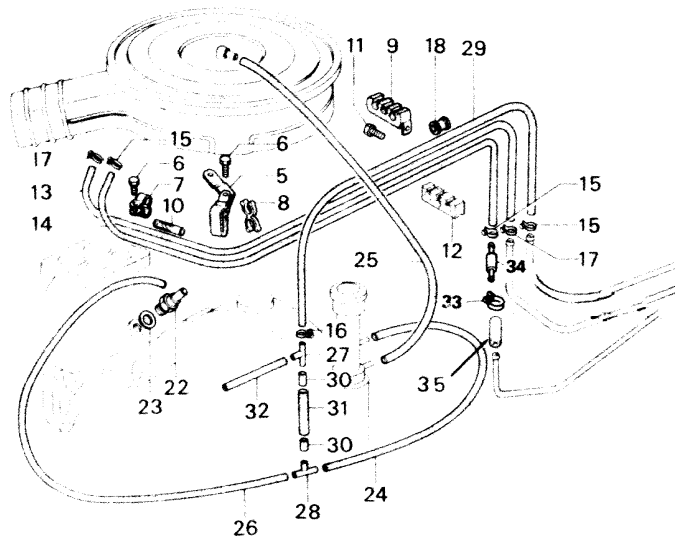

No.	Part Number	Description	Q'ty	Remarks
1	0223 13 363	Rubber, Insulation-Fuel Pump	2	
2	1854 13 400 A	Pump, Fuel	1	
•	1854 13 400 B	Pump, Fuel	1	77/6 ~ Δ
3	0866 13 402 B	Wire, Earth-Fuel Pump	1	
4	99940 0600	Nut, Fuel Pump	4	
	99952 0600	Washer, Plain	2	
5	1757 13 445	Clip	1	
6	99796 0610	Bolt, Clip	2	
7	8503 13 446 A	Clip, Fuel Pipe	1	
8	1570 13 447	Clip, Fuel Pipe	1	
9	8527 13 447	Clip, Fuel Pipe	1	
10	1883 13 448	Protector	1	
11	99786 0616	Bolt, Clip	2	
	99952 0600	Washer, Plain	2	
12	1757 13 449	Protector, Pipe	1	
13	99348 08930	Pipe, Fuel Main	1	Ord. By 99349 08750 (1.75m)
14	99348 06930	Pipe, Fuel Return	1	Ord. By 99349 06750 (1.75m)
15	99283 1000	Clip, Fuel Pipe & Evaporation Pipe	3	
16	99283 1100	Clip, Fuel Pipe	1	
17	99283 1200	Clip, Fuel Pipe	2	
18	99681 1503	Protector, Pipe	3	

FUEL & EVAPORATION PIPING

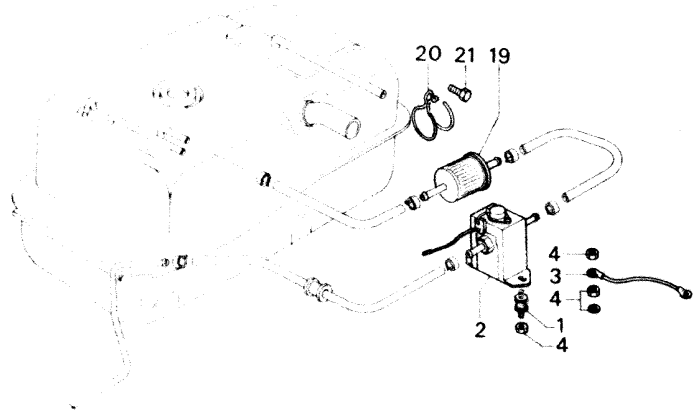
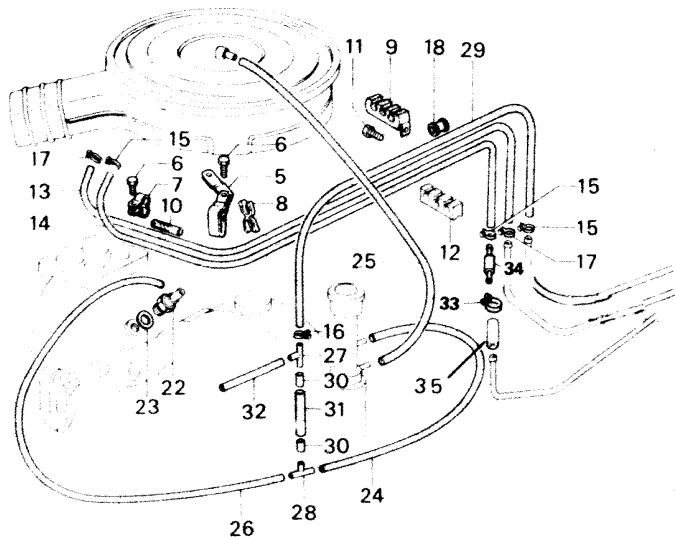

FUEL & EVAPORATION PIPING

No.	Part Number	Description	Q'ty	Remarks
19	0222 13 470B	Filter, Fuel	1	
20	0381 13 481	Clamp, Fuel Filter	1	
21	99786 0612	Bolt, Fuel Filter	1	
22	1757 13 780	Valve, Ventilation-IN. Manifold	1	
23	99564 1600	Gasket, Ventilation Valve	1	
24	3565 13 785	Hose, Ventilation-"T" Joint - Oil Filler Pipe	1	
25	1757 13 786B	Hose, Ventilation-Air Cleaner - Intermediate Housing	1	
26	3565 13 788A	Hose, Ventilation-"T" Joint - Ventilation Valve	1	
27	1029 13 700	Joint, "T" (Except Calif.)	1	
28	1757 13 790	Joint, "T"	1	
•	1757 13 790A	Joint, "T"	1	77/10 ~ Δ
29	1854 13 792A	Hose, Evaporation-"T" Joint - Evaporation Pipe	1	
30	3565 13 795	Insert, "T" Joint	2	
31	1757 13 787	Hose, Evaporation-"T" Joint - "T" Joint (Except Calif.)	1	
32	3565 13 915	Tube, E.C.V. Valve - "T" Joint (Except Calif.)	1	
33	8527 13 449	Clip, Hose	1	
•	8527 13 459	Clip, Hose	1	77/6 ~ ○
34	3648 13 270	Valve, Check	1	
35	99348 06100	Pipe, Fuel	1	Ord. by 99349 06750 (1.75m)

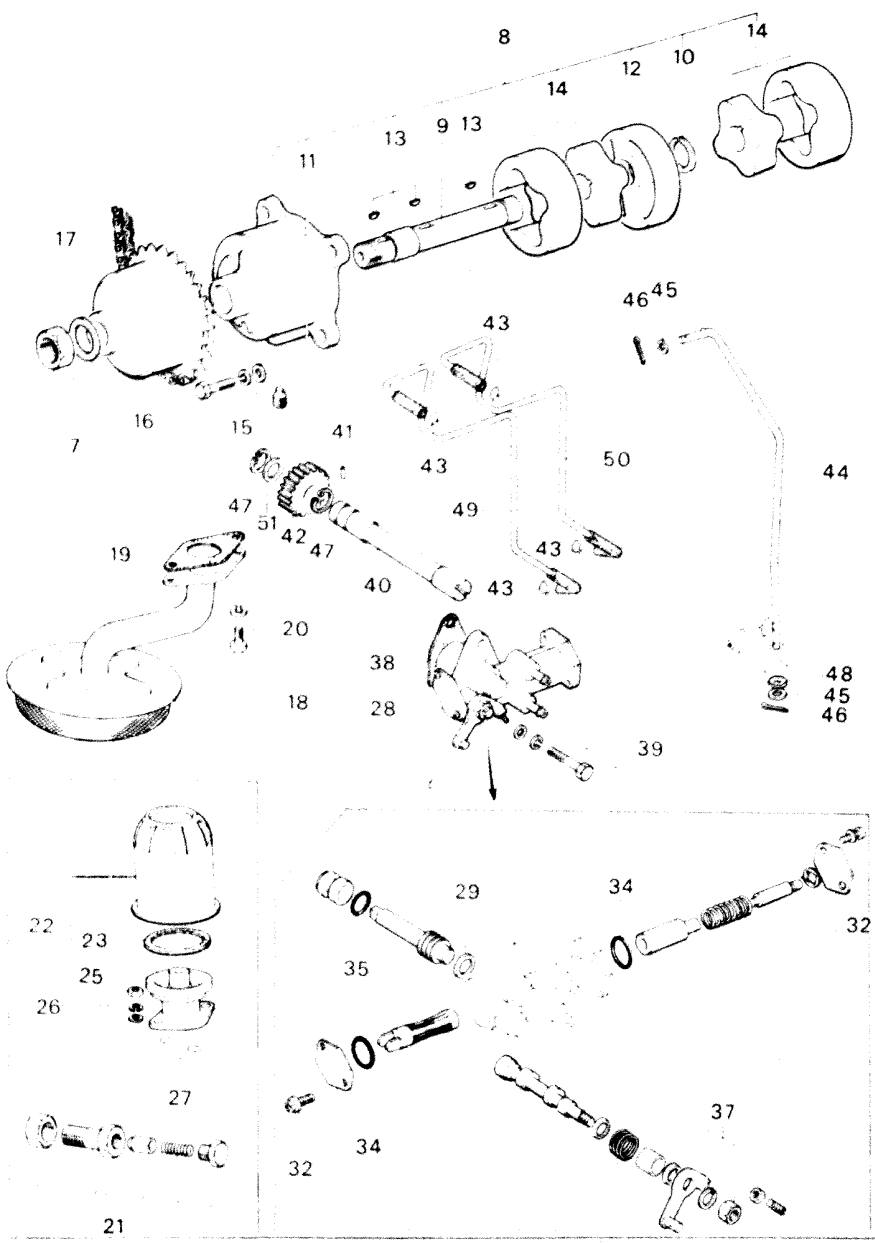

No.	Part Number	Description	Q'ty	Remarks
1	1757 14 020	Adjuster, Chain	1	
2	0823 14 130	Adjuster	1	
3	0823 14 131	Spring	1	
4	1757 14 132	Body	1	
5	0839 14 133	Plate, Guide	1	
6	99906 0600	Nut, Chain Adjuster	2	
	99971 0600	Washer, Spring	2	
7	99922 1200	Nut, Oil Pump Drive Gear	1	
	99979 1200	Washer, Tab	1	
8	8501 14 100	Pump, Oil	1	
9	1757 14 112	Shaft, Oil Pump	1	
10	0810 14 113	Ring, Snap	1	
11	0839 14 117	Bolt, Lock	1	
12	8501 14 110	Plate, Middle, Oil Pump	1	
13	0839 14 119B	Key	3	
14	8501 23 882	Rotor Set, Oil Pump	2	
	8501 14 110	Rotor Set, Oil Pump	2	77/7 ~ 0
15	99796 0616	Bolt, Oil Pump	4	

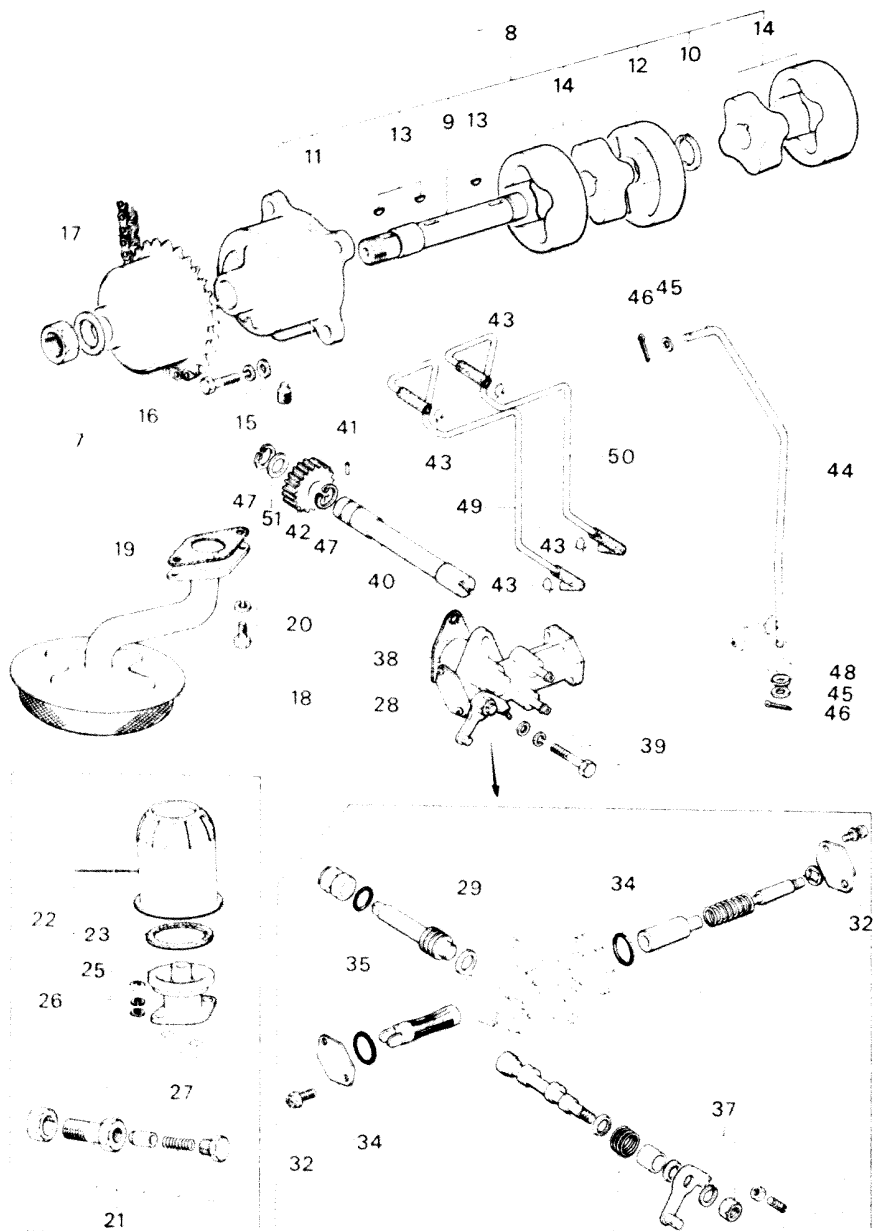

No.	Part Number	Description	Q'ty	Remarks
16	0839 14 141 A	Gear, Drive-Oil Pump	1	
17	0839 14 142	Chain	1	
18	0866 14 160 E	Strainer, Oil	1	
19	0810 14 171	Gasket, Oil Strainer	1	
20	99806 0616	Bolt, Oil Strainer	2	
	99971 0600	Washer, Spring	2	
21	3648 14 250	Regulator, Pressure	1	
22	0813 23 802 B	Cartridge, Oil Filter	1	Ord. by 0866 23 802
23	0813 23 803	Gasket	1	
25	0839 23 801	Cover	1	
26	99901 0800	Nut, Oil Filter	2	
	99953 0800	Washer, Plain	2	
	99971 0800	Washer, Spring	2	
27	99541 01601	Ring, "O"-Oil Filter	2	
28	1757 14 600	Pump, Metering Oil	1	
29	0820 23 832 B	Washer, Thrust	1	

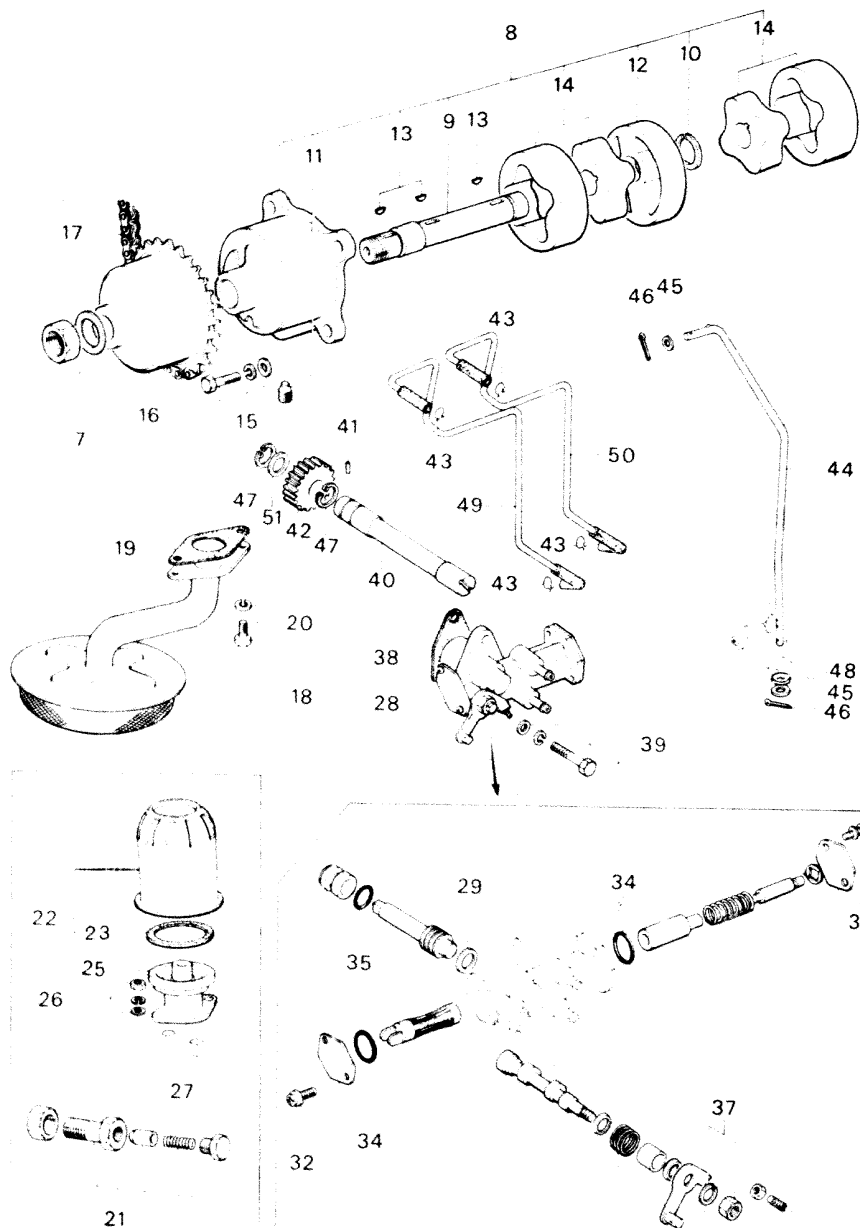

No.	Part Number	Description	Q'ty	Remarks
47	99576 0800	Ring, Snap-Driven Gear Shaft	2	
48	1757 14 652	Shim (t=1.0)	1	} Selective use
	1757 14 653	Shim (t=2.0)		
49	3565 14 660 A	Tube, Metering Oil	1	
50	3565 14 670 A	Tube, Metering Oil	1	
51	0810 18 276	Shim, Adjust (t=0.6)	2	} Selective use
	0810 18 277	Shim, Adjust (t=0.3)		

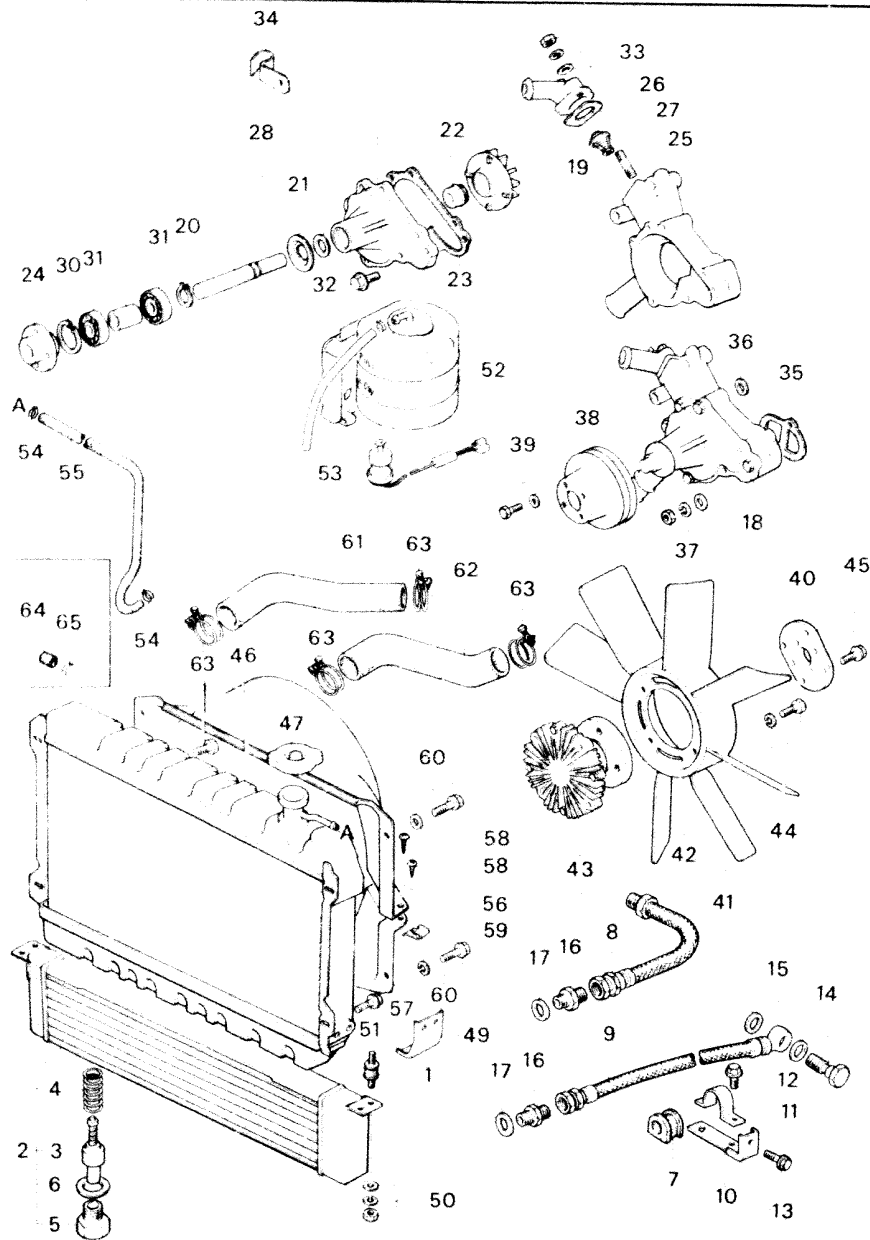

No.	Part Number	Description	Qty	Remarks
1	1715 15 312	Rubber, Insulation	4	
2	1854 14 700	Cooler, Oil	1	
3	1757 14 810	Pellet, Thermo	1	
4	1757 14 821	Spring, Pellet	1	
5	1757 14 822	Nut, Stopper	1	
6	1757 14 823	Gasket	1	
7	0813 14 716	Protector, Oil Hose	1	
8	0865 14 720	Hose, Oil	1	
9	1570 14 730A	Hose, Oil	1	
10	1757 14 740	Bracket, Oil Hose (Manual)	1	
	1758 14 740	Bracket, Oil Hose (Automatic)	1	
11	0839 14 745	Clip, Oil Hose	1	
12	99806 0616	Bolt, Clip	1	
	99971 0600	Washer, Spring	1	
13	99796 0812	Bolt, Bracket	1	
14	99381 1400	Bolt, Connector-Oil Hose	1	
15	99562 1800	Gasket	2	

COOLING SYSTEM

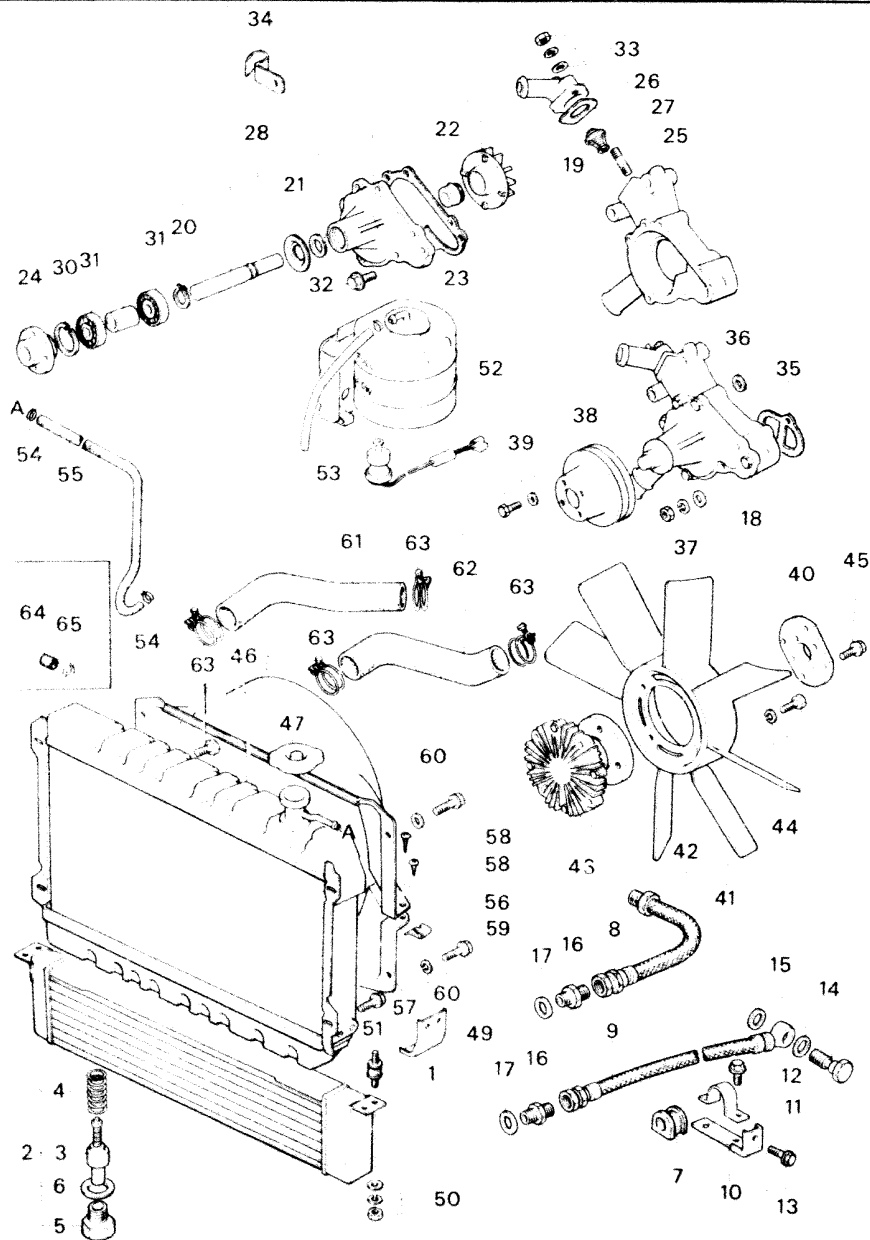

COOLING SYSTEM

No.	Part Number	Description	Qty	Remarks
16	99384 1200F	Joint, Union	2	
17	99564 1600	Gasket	2	
18	8527 15 010	Pump, Water	1	
•	8527 15 010A	Pump, Water	1	77/9 ~ Δ
•	8553 15010B	Pump, Water	1	77/9 ~ Δ
19	2090 15 104	Stud	2	
20	1757 15 114	Ring, Snap	1	
21	1757 15 118	Plate, Dust Seal	1	
22	1757 15 120	Seal, Water	1	
23	1757 15 132	Gasket, Pump Cover	1	
24	1757 15 152A	Boss, Pulley	1	
•	1757 15 152B	Boss, Pulley	1	77/9 ~ Δ
25	0839 15 171A	Thermostat	1	
•	8553 15 171	Thermostat	1	77/6 ~ ○
26	8519 15 172	Cover, Thermostat	1	
27	1757 15 173	Gasket, Thermostat	1	
28	3648 15 130	Cover, Pump	1	
•	3648 15 130A	Cover, Pump	1	77/9 ~ Δ
•	3648 15 130B	Cover, Pump	1	77/9 ~ Δ

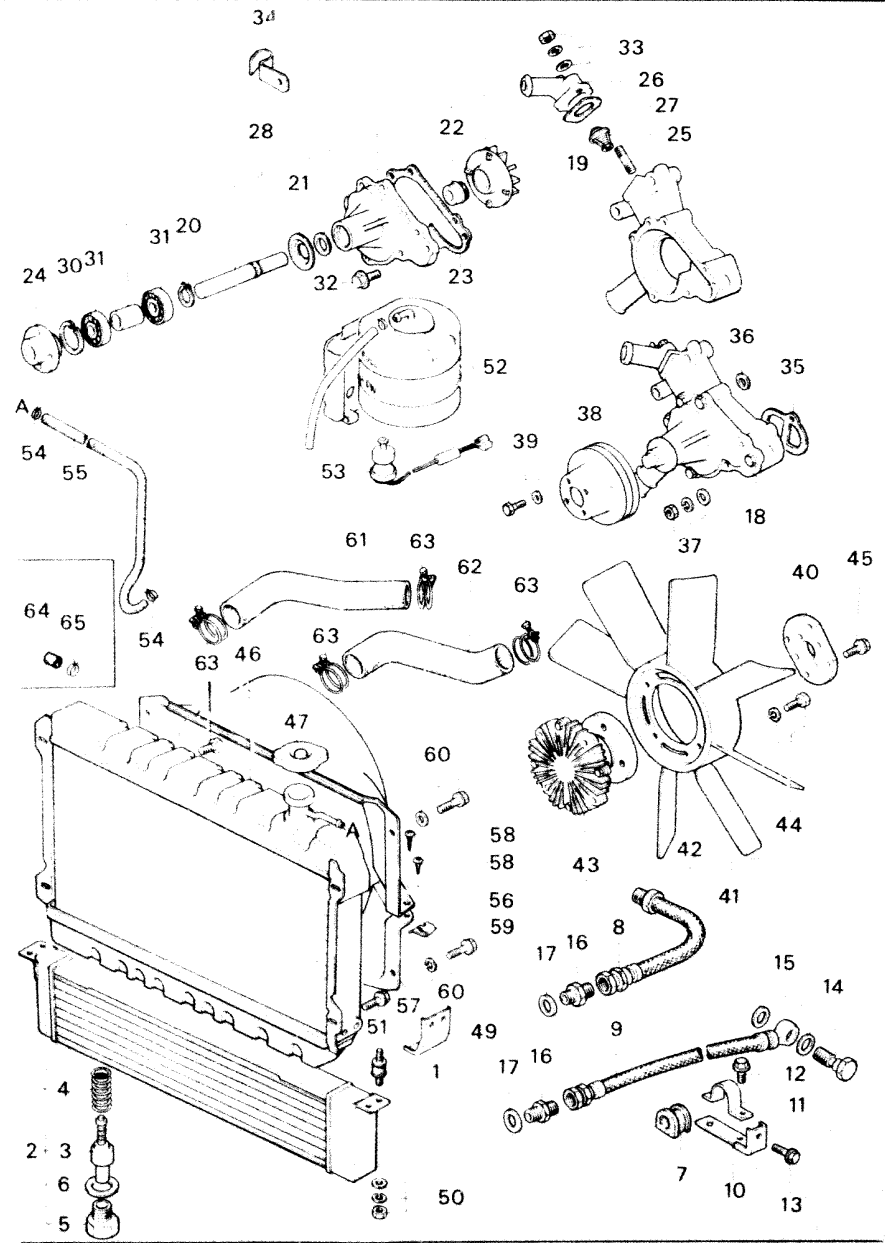

1-E6

No.	Part Number	Description	Qty	Remarks
29	3648 15 180B	Valve, Control	1	
30	99574 3000	Ring, Retaining	1	
31	99606 72030	Bearing, Ball	2	
32	99796 0820	Bolt, Pump Cover	2	
	99951 0816	Washer, Plain	1	
33	99901 0800	Nut, Thermostat Cover	2	
	99953 0800	Washer, Plain	2	
	99971 0800	Washer, Spring	2	
34	3565 14 662A	Clip	1	
35	1757 15 105A	Gasket, Water Pump	1	
36	1757 15 106	Gasket	2	
37	99901 0800	Nut, Water Pump	4	
	99971 0800	Washer, Spring	4	
38	1757 15 151B	Pulley, Water Pump	1	
39	99796 0620	Bolt	4	
40	1907 15 211	Spacer, Fan Drive	1	
•	1907 15 211A	Spacer, Fan Drive	1 77/9 ~ Δ	
41	3648 15 250	Fan & Fan Drive	1	
42	3648 15 200	Fan, Cooling	1	

14 **15** **COOLING SYSTEM**

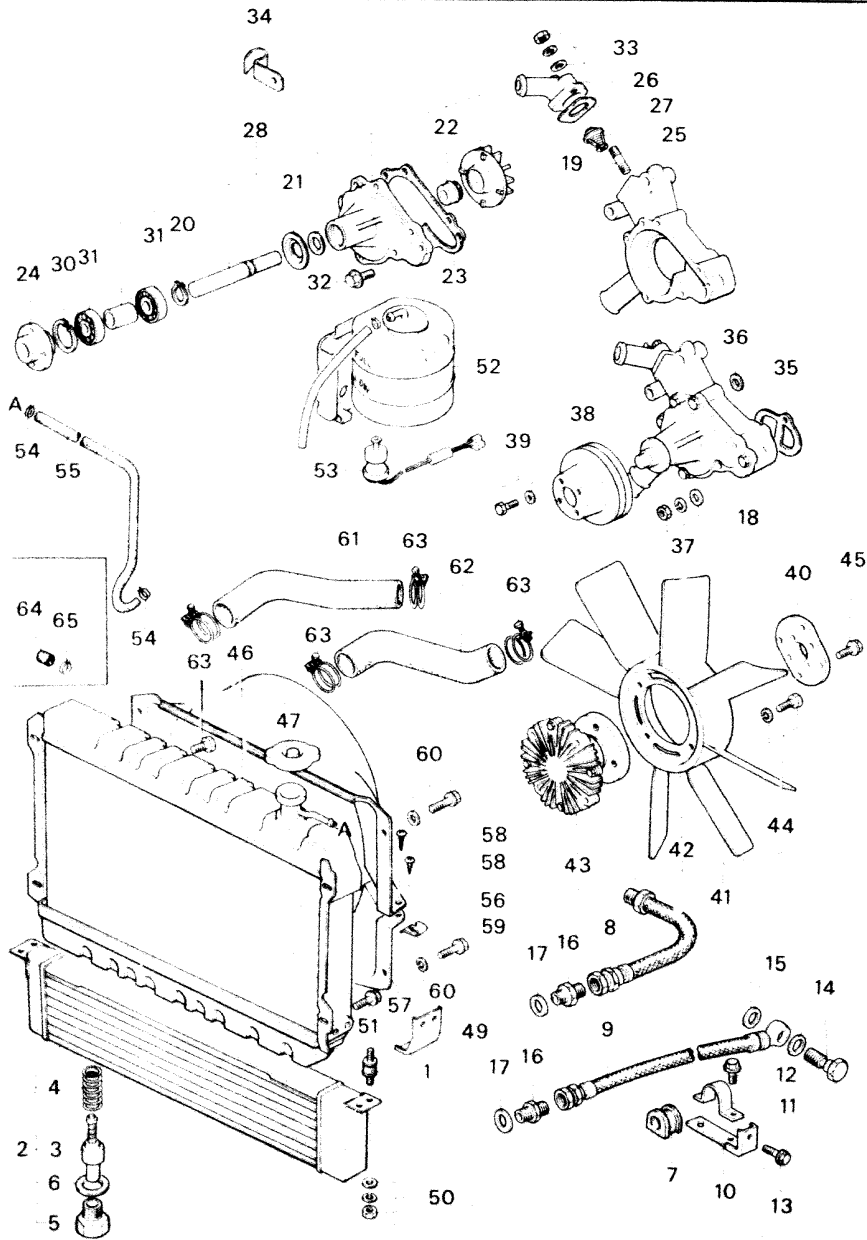

14 **15** **COOLING SYSTEM**

No.	Part Number	Description	Q'ty	Remarks
43	1202 15 210	Fan Drive	1	
44	99806 0614	Bolt, Fan & Fan Drive	4	
	99952 0600	Washer, Plain	4	
	99971 0600	Washer, Spring	4	
45	99796 0620	Bolt, Fan Drive	4	
46	1854 15 310D	Radiator (Manual)	1	
	1856 15 310E	Radiator (Automatic)	1	
47	0766 15 205	Cap	1	
48	1011 15 317	Cock, Water Drain	1	
49	1854 15 312	Bracket, Radiator & Oil Cooler	2	
50	99940 0600	Nut, Bracket	8	
51	99786 0816	Bolt, Radiator	4	
	99952 0800	Washer, Plain	4	
52	3565 15 350B	Tank, Sub	1	
53	3565 15 370	Switch, Level	1	
54	99283 1300	Clip, Water Hose	2	

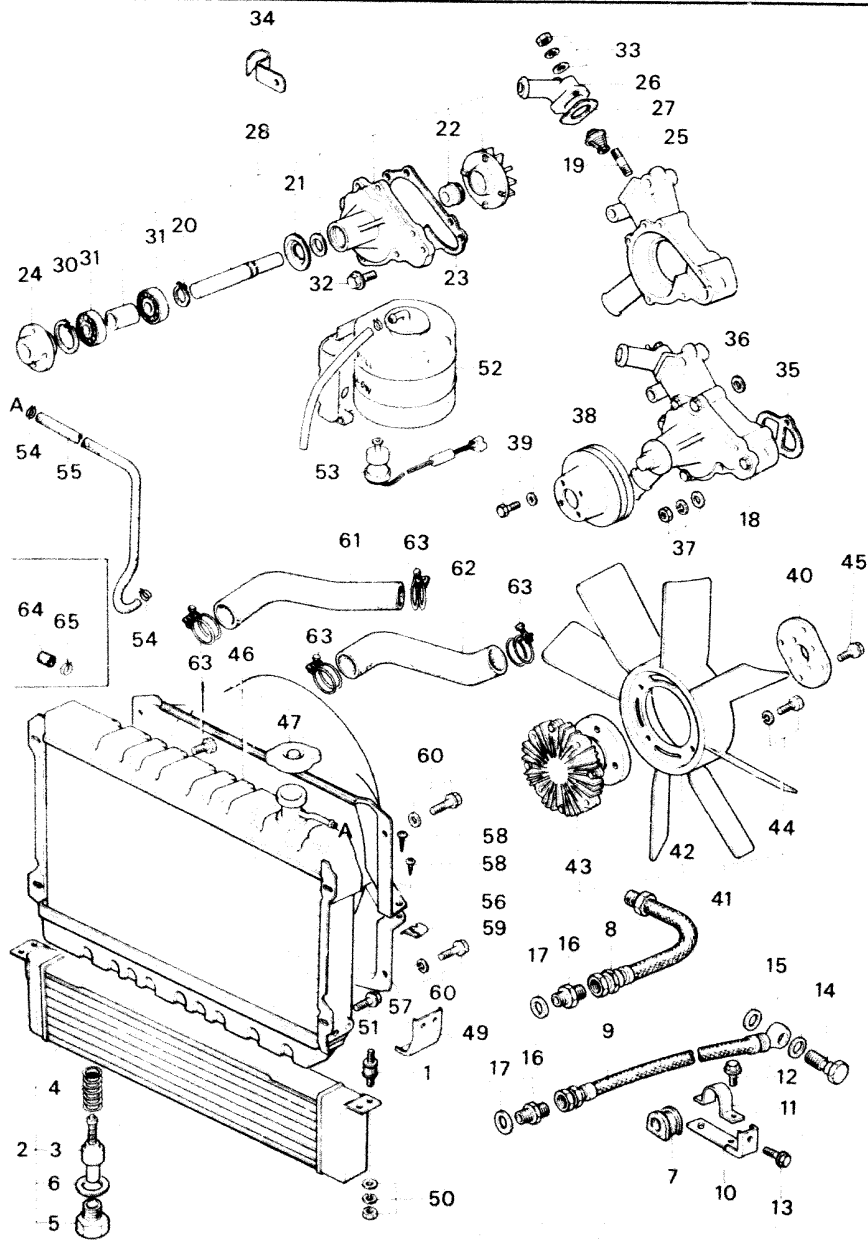

No.	Part Number	Description	Q'ty	Remarks
55	1854 15 351C	Hose, Water-Sub Tank	1	
56	3900 15 411	Shroud, Radiator-Upper	1	
57	3900 15 421	Shroud, Radiator-Lower	1	
58	99865 0516	Screw	5	
59	0820 56 905	Nut, Spring	5	
60	99796 0812	Bolt, Radiator Shroud	4	
	99952 0818	Washer, Plain	4	
61	1854 15 511	Hose, Water-Thermostat-Radiator	1	
62	1854 15 521	Hose, Water-Radiator-Water Pump	1	
63	99282 4900	Band, Hose-Water Hose	4	
64	0864 61 061A	Cover (W/O Car Heater)	1	
65	99282 2600	Band, Hose (W/O Car Heater)	1	

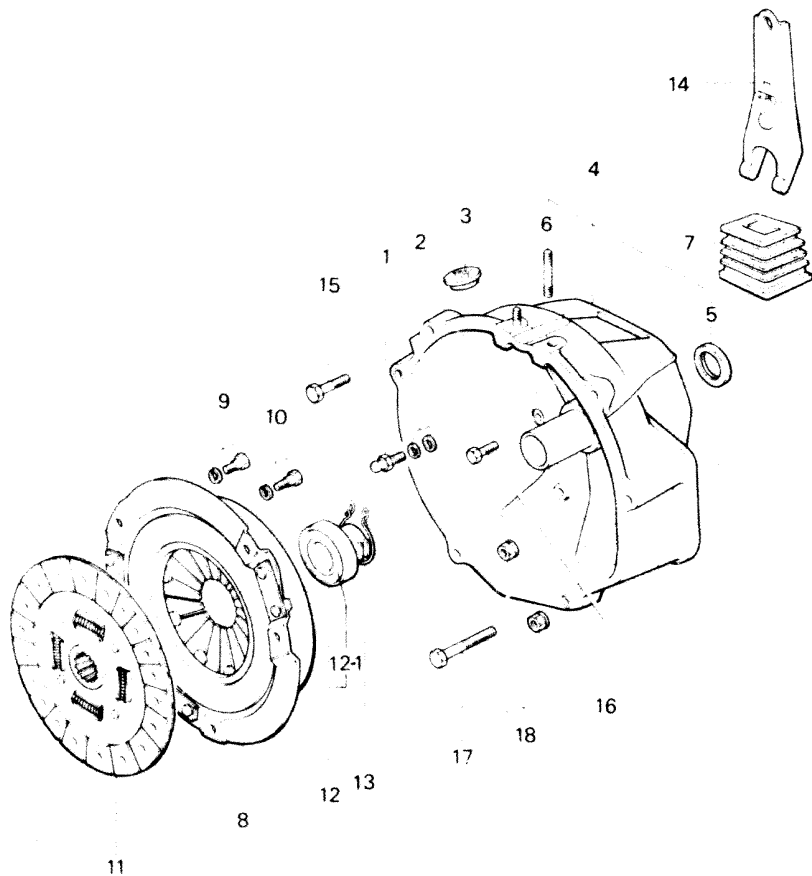

No.	Part Number	Description	Q'ty	Remarks
1	0603 16 102B	Pin, Pivot	1	
2	99953 1000	Washer, Plain	1	
	99971 1000	Washer, Spring	1	
3	0813 16 112	Cover, Top Hole	1	
4	1881 16 210B	Housing, Clutch	1	
5	0603 16 103	Oil Seal	1	
6	0222 16 105	Stud	2	
7	0866 16 214A	Cover, Dust	1	
8	0895 16 410	Cover, Clutch	1	
9	0839 16 432	Bolt, Reamer - Clutch Cover	2	
	99971 0800	Washer, Spring	2	
10	99753 78118	Bolt, Clutch Cover	4	
	99971 0800	Washer, Spring	4	
11	0895 16 460B	Disc, Clutch	1	
12	0620 16 510	Collar, Clutch Release	1	
12-1	0222 16 222	Bearing	1	

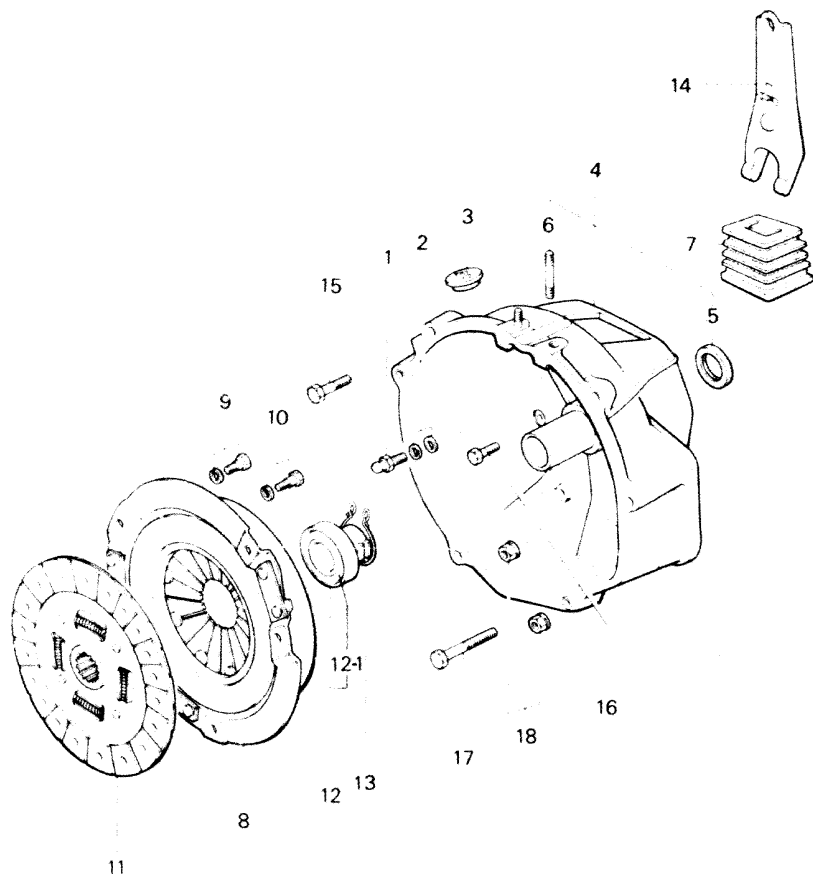

No.	Part Number	Description	Qty	Remarks
13	0820 16 515	Spring, Clutch Release Collar	1	
14	04 $\frac{1}{4}$ 16 520	Fork, Clutch Release	1	
15	99796 1045	Bolt, Clutch Housing	1	
16	99796 1035	Bolt, Clutch Housing	2	
17	99796 1090	Boit, Clutch Housing	1	
18	99940 1001	Nut, Clutch Housing	8	

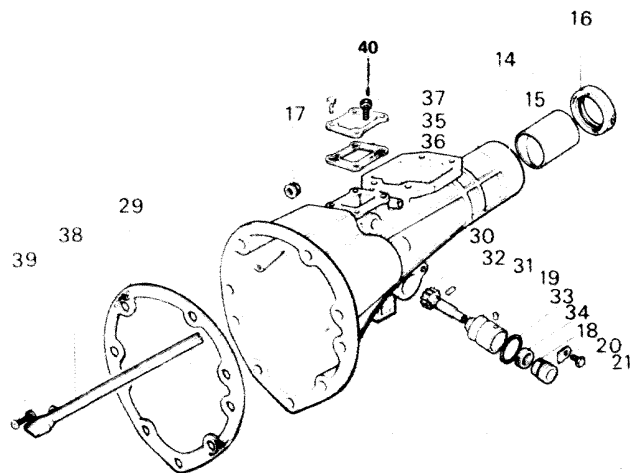
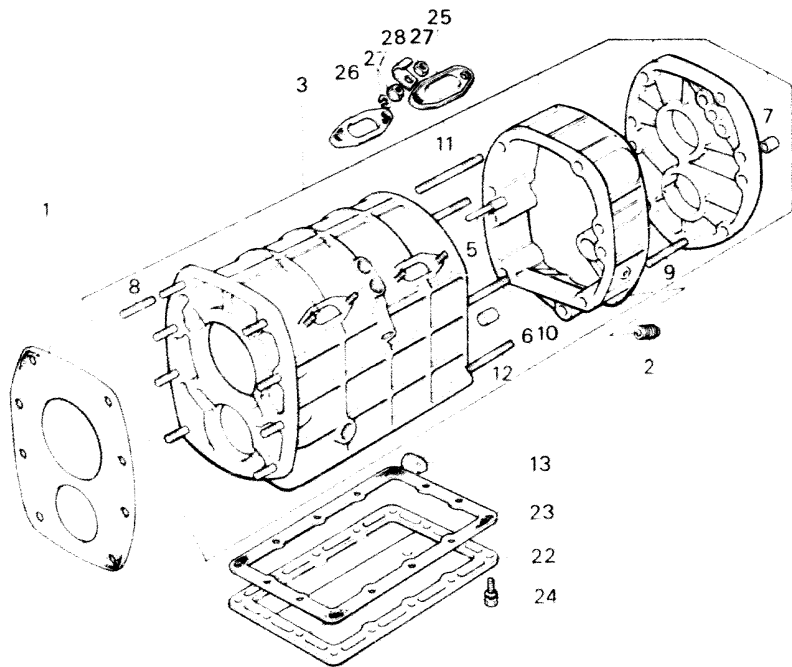

No.	Part Number	Description	Q'ty	Remarks
1	0839 17 111	Gasket, Front	1	
2	0107 17 121	Plug, Magnet-Center Housing	1	
3	3778 17 200A	Case Set, T / mission	1	
4	0839 17 105	Stud, Blind Cover	2	
5	99852 0610F	Stud	2	
5	0862 17 660A	Pass, Oil	1	
6	99233 1225	Pin, Knock	2	
7	99246 1232	Pin, Dowel-Bearing Housing	2	
8	99855 1025	Stud	8	
9	99855 1045	Stud, Center Housing	1	
10	99857 10135	Stud	3	
11	99857 10160	Stud	1	
12	90857 10135	Stud	2	
13	99502 4000	Plug, Oil	1	
14	3778 17 330B	Housing, Extension	1	
● 15	0398 17 333	Bush	1	

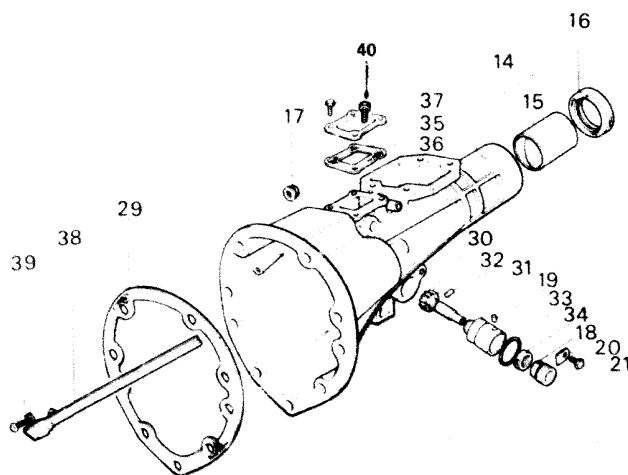
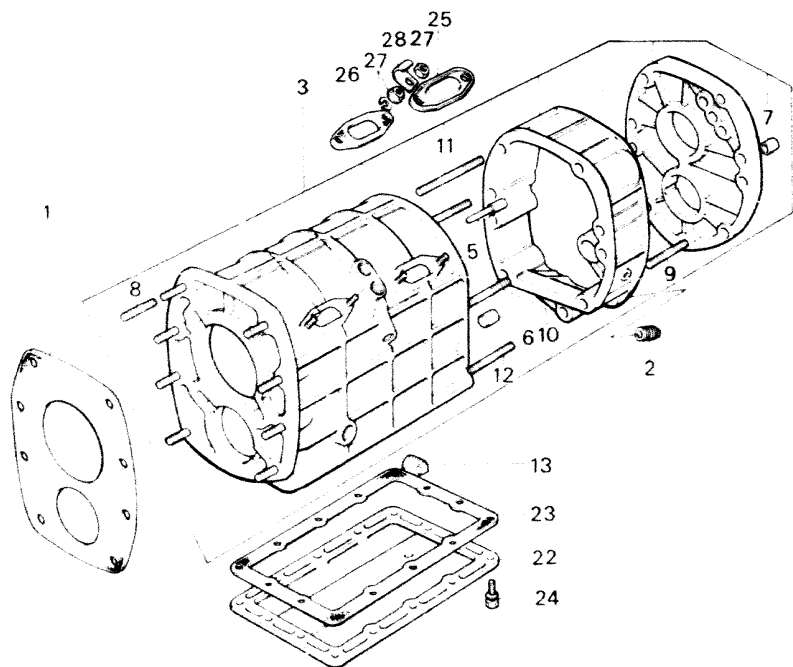

No.	Part Number	Description	Qty	Remarks
16	0437 17 335	Oil Seal, Extension Housing	1	
17	99940 1001	Nut, Extension Housing - T-mission Case	7	
18	0862 17 351	Joint, Speedometer Cable	1	
19	0187 17 352	Pin, Dowel-Speedometer Sleeve	1	
20	0111 17 354	Plate, Lock-Speedometer Cable Joint	1	
21	99796 0612	Bolt, Lock Plate	1	
22	1281 17 371	Cover, Under	1	
23	0862 17 375	Gasket, Under Cover	1	
24	99796 0620	Bolt, Under Cover	14	
25	0810 17 381A	Cover, Blind	2	
26	0810 17 385	Gasket, Blind Cover	2	
27	99906 0600	Nut, Blind Cover	6	
	99971 0600	Washer, Spring	4	
28	99276 0506	Clip, Wire Harness	2	
29	3778 17 393	Gasket, Rear	1	
30	3790 17 441	Gear, Driven-Speedometer	1	
31	0862 17 442	Sleeve, Gear-Speedometer	1	
32	99222 0216	Pin, Spring-Speedometer Sleeve	1	
33	99541 02211	Ring, "O"	1	
34	99586 10207	Oil Seal	1	

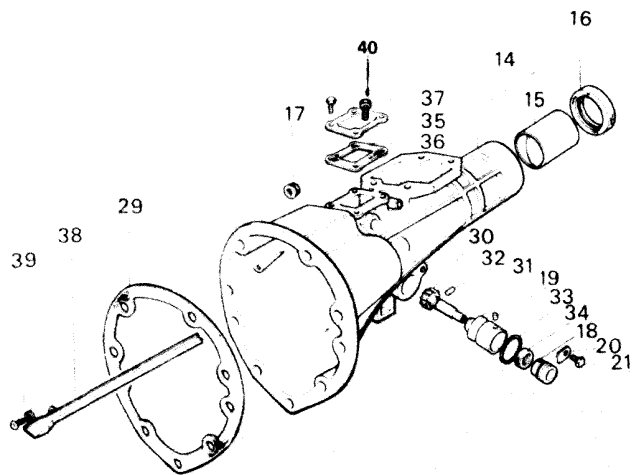
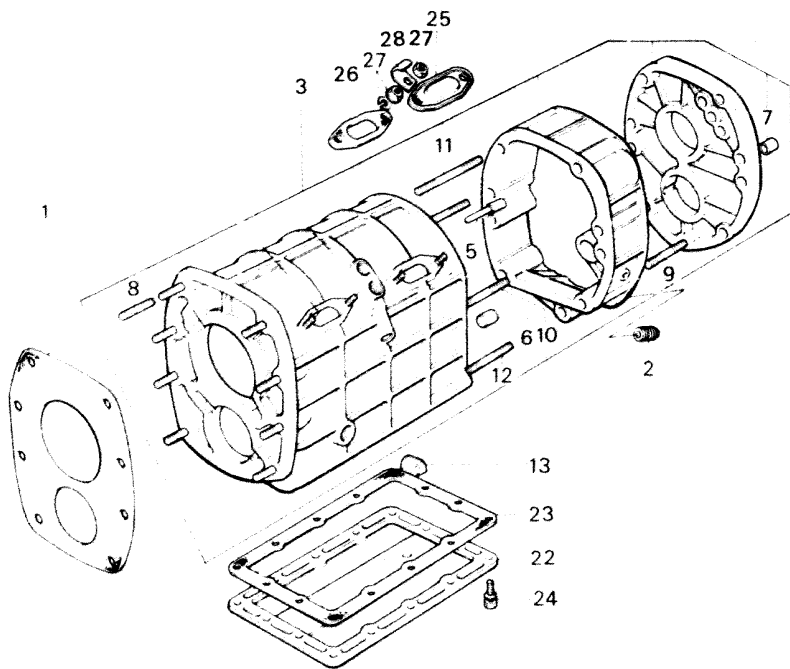

No.	Part Number	Description	Q'ty	Remarks
35	0862 17 531A	Cover, Blind	1	
36	0862 17 535	Gasket	1	
37	99796 0608	Bolt, Blind Cover	4	
38	0862 17 540B	Pass. Oil	1	
39	99806 0612	Bolt, Oil Pass	1	
	99971 0600	Washer, Spring	1	
40	0884 17 530	Breather, Air	1	
	3778 89 175	Gasket Set, T. mission	1	
	0839 17 111	Gasket, Case Front	1	
	0862 17 375	Gasket, Under Cover	1	
	0810 17 385	Gasket, Blind Cover	2	
	3778 17 393	Gasket, Extension	1	
	0303 17 474	Gasket, Control Case Cover	1	
	0271 17 478	Gasket, Control Case	1	
	0862 17 535	Gasket, Blind Cover	1	
	99562 1400	Gasket, Spring Cap	3	
	99564 0800	Gasket, Gear Set	1	
	99564 1000	Gasket, Spring Cap	2	
	99564 1800	Gasket, Magnet Plug	1	

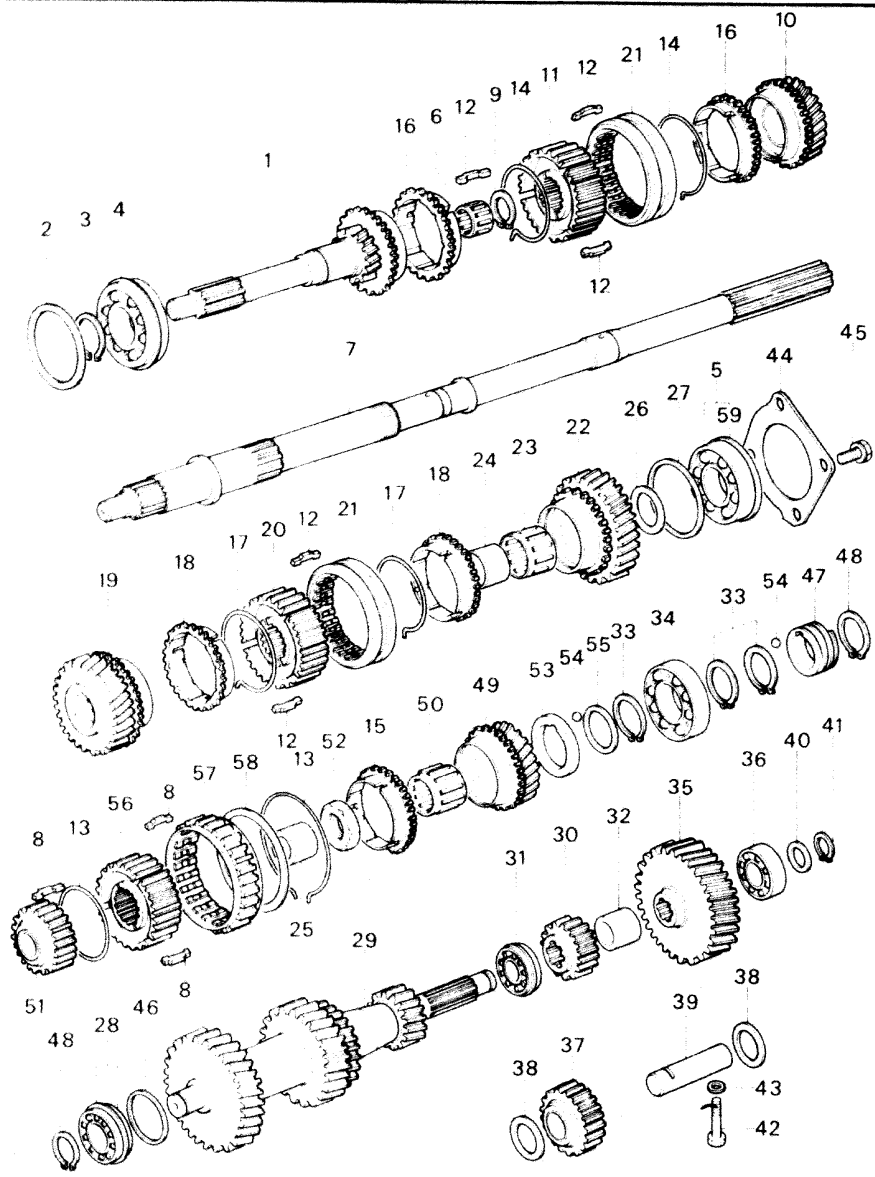

No.	Part Number	Description	Qty	Remarks
1	1853 17 201	Gear, Main Drive	1	
2	99963 6910	Shim, Adjust (t. 0.1)	2	Selective use
	99963 6930	Shim, Adjust (t. 0.3)	1	
3	99573 3500	Ring, Snap	1	
4	99606 33070	Bearing, Ball	1	
5	0810 17 204	Bearing, Ball (Fig No 59 included)	1	
6	0810 17 205	Bearing, Needle Roller	1	
7	3648 17 221	Shaft, Main	1	
8	0187 17 243	Key, Synchronizer	3	
9	0317 17 225	Ring, Snap	1	
10	3778 17 231	Gear (3rd)	1	
11	1853 17 241	Hub, Clutch (3rd & 4th)	1	
12	1853 17 243	Key, Synchronizer	6	
13	0103 17 244 A	Spring, Synchronizer	2	
14	1853 17 244	Spring, Synchronizer	2	
15	0862 17 245 A	Ring, Synchronizer	1	
16	1853 17 245	Ring, Synchronizer	2	
17	1853 17 264	Spring, Synchronizer	2	
18	1853 17 265	Ring, Synchronizer	2	
19	3778 17 251	Gear (2nd)	1	

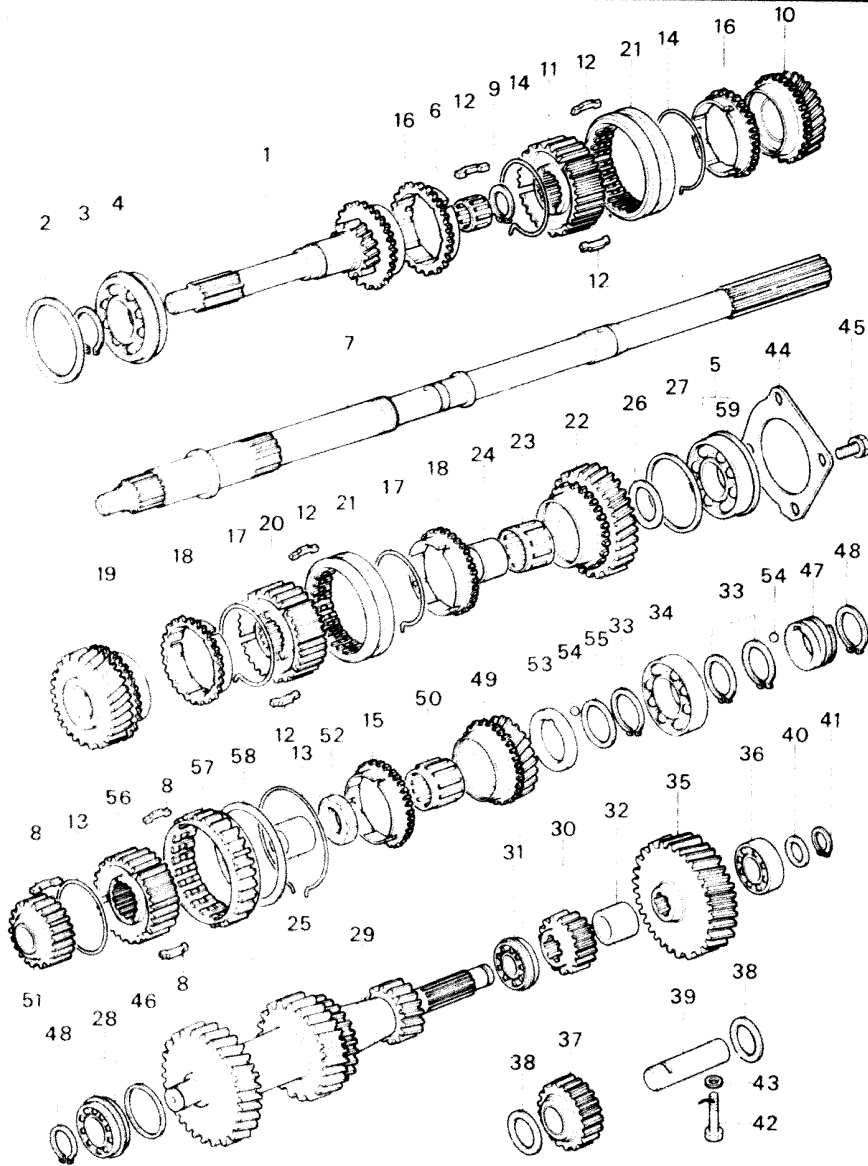

No.	Part Number	Description	Qty	Remarks
20	1853 17 261 A	Hub, Clutch (1st & 2nd)	1	
21	1853 17 262	Sleeve, Clutch Hub	2	
22	3778 17 271	Gear (1st)	1	
23	0884 17 274	Bearing, Needle	4	
24	0884 17 275A	Race, Inner	1	
25	3648 17 275	Race, Inner	1	
26	0839 17 276	Washer, Thrust (L - 2.5)	1	
	0839 17 277	Washer, Thrust (L - 3.0)	2	Selective use
	0839 17 278	Washer, Thrust (L - 3.5)	1	
27	0839 17 287	Shim, Adjust (t - 0.1)	2	Selective use
	0839 17 288	Shim, Adjust (t - 0.3)	1	
28	0821 17 297	Bearing, Ball	1	
29	0862 17 301 A	Gear, Counter Shaft	1	
30	3648 17 302	Gear, Counter Reverse	1	
	0821 17 302	Gear, Counter Reverse	1	77/9 ~ O
31	9821 17 303	Bearing, Needle	1	
32	0884 17 J04	Spacer	1	
33	0839 17 305	Ring, Retaining	3	
	0839 17 305A	Ring, Retaining	3	77/6 ~ Δ
34	99616 63050	Bearing, Ball	1	
35	3648 17 308	Gear, Counter	1	
36	99606 63440	Bearing, Ball	1	

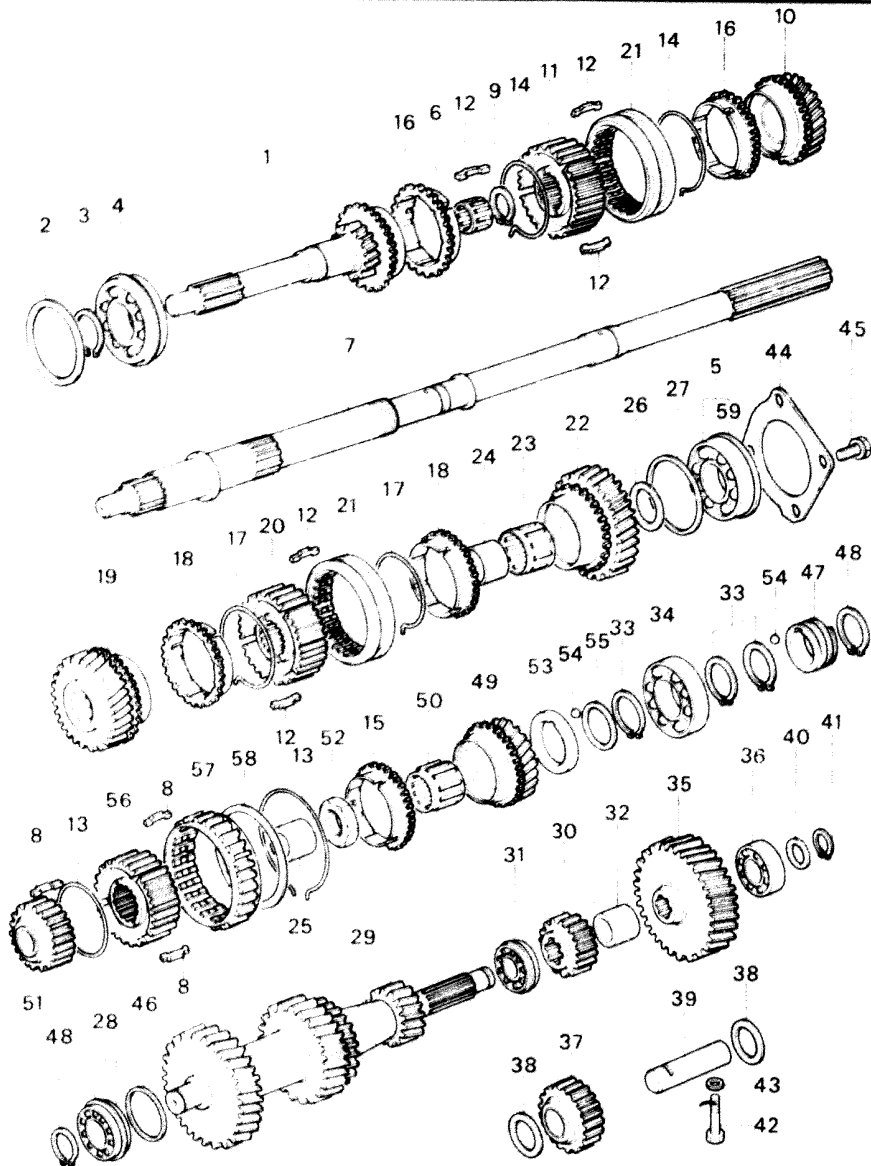

No.	Part Number	Description	Qty	Remarks
37	3648 17 310	Gear, Reverse Idle	1	
38	0821 17 313	Washer, Thrust	2	
39	0884 17 315	Shaft, Reverse Idle Gear	1	
40	0884 17 316A	Washer, Adjust (t. 2.00)	Selective use	1
	0884 17 317A	Washer, Adjust (t. 2.15)		
	0884 17 318A	Washer, Adjust (t. 2.30)		
41	99573 2200	Ring, Snap	1	
42	4069 17 323	Bolt, Set	1	
43	99564 0800	Gasket, Set Bolt	1	
44	0884 17 325B	Stopper, Bearing	1	
45	99781 0820	Boit, Bearing Stopper	4	
	99952 0800	Washer, Plain	4	
46	0305 17 327	Shim, Adjust (t. 0.1)	Selective use	1
	0305 17 328	Shim, Adjust (t. 0.3)		
47	0862 17 341	Gear, Drive-Speedometer	1	
48	99573 2500	Ring, Snap	2	
49	3648 17 611	Gear, Over Top	1	
50	0884 17 612	Bearing, Needle	1	
51	3648 17 281 B	Gear, Reverse	1	
	3648 17 281 C	Gear, Reverse	1	77/5 ~ Δ
52	3648 17 629	Nut, Lock	1	

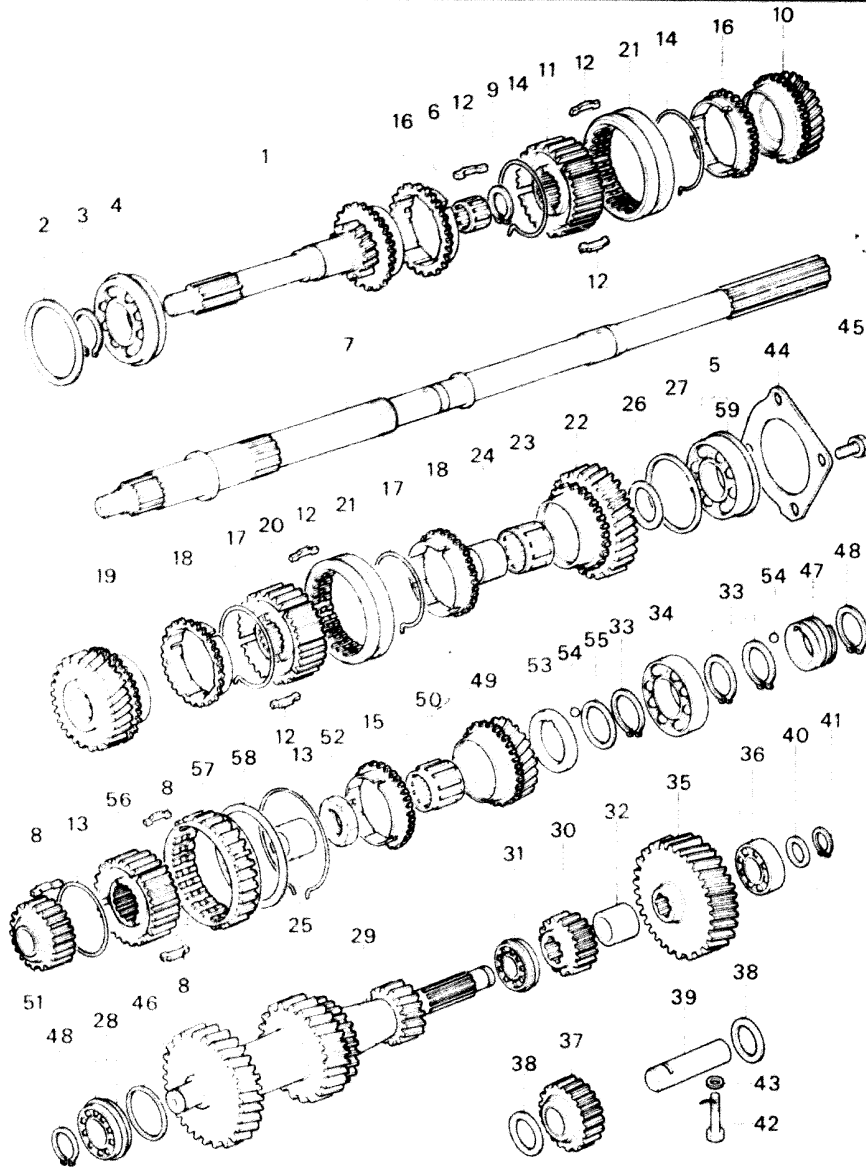

No.	Part Number	Description	Qty	Remarks
53	0884 17 633 A	Washer, Thrust Lock (t-6.4)		Selective use 1
	0884 17 634 A	Washer, Thrust Lock (t-6.5)		
	0884 17 635 A	Washer, Thrust Lock (t-6.6)		
	0884 17 636 A	Washer, Thrust Lock (t-6.7)		
54	99611 1500	Ball, Steel	2	
55	0862 17 641	Washer, Adjust (t-1.9)		Selective use 1
	0862 17 642	Washer, Adjust (t-2.0)		
	0862 17 643	Washer, Adjust (t-2.1)		
	0862 17 644	Washer, Adjust (t-2.2)		
56	3648 17 621	Hub, Clutch	1	
57	3648 17 622 A	Sleeve, Clutch Hub	1	
58	3648 17 626	Ring, Retaining	1	
59	0881 22 297	Clip, Ball Bearing (included in Fig No 5)	1	

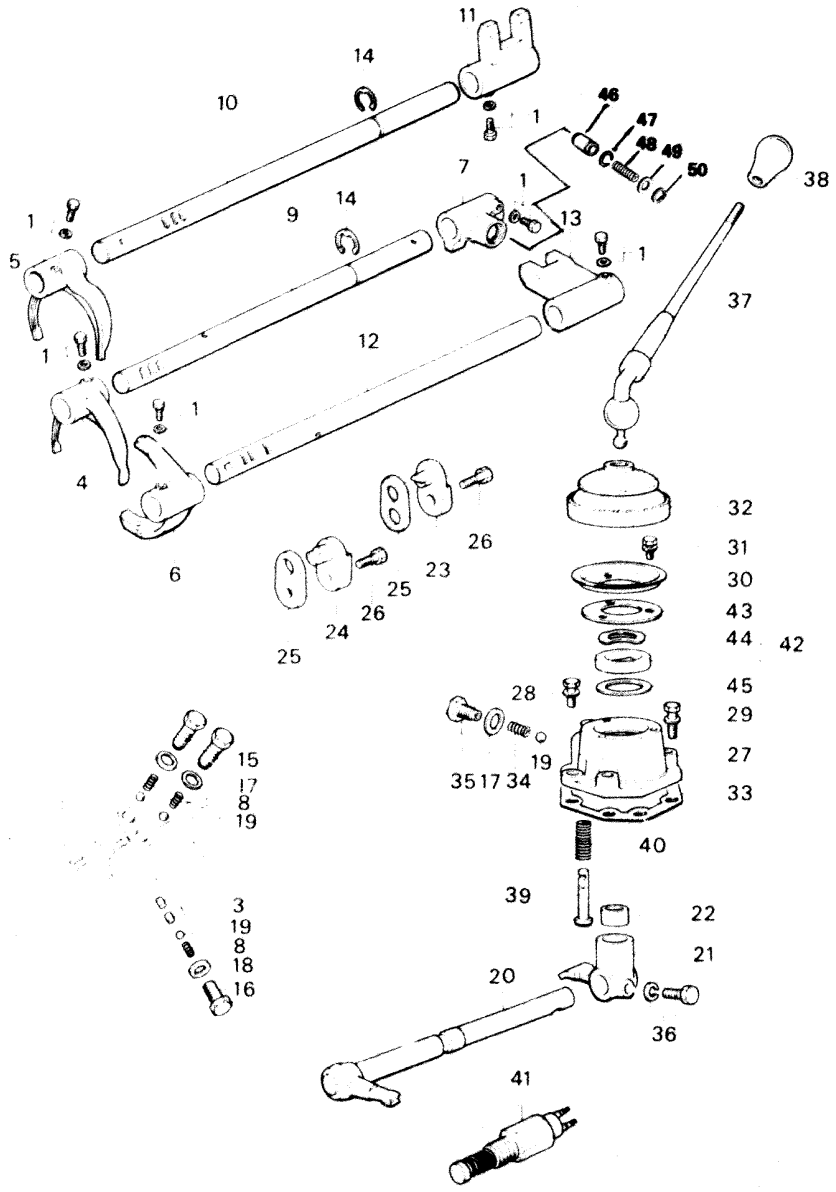

No.	Part Number	Description	Qty	Remarks
1	0118 17 313	Screw, Shift Fork & Rod	6	
	99971 0601	Washer Spring	6	
2	0111 17 323	Key, Control Lever	1	
3	0114 17 351	Pin, Interlock	2	
4	1853 17 402A	Fork, Shift (1st & 2nd)	1	
5	1853 17 404	Fork, Shift (3rd & 4th)	1	
6	3778 17 406	Fork, Shift (Over Top & Reverse)	1	
7	3648 17 410	Gate, Shift (1st & 2nd) (Fig.No. 46,47,48,49,50 included)	1	
8	0103 17 411	Spring, Cap	3	
9	0498 17 411A	Rod, Shift (1st & 2nd)	1	
10	0498 17 421B	Rod, Shift (3rd & 4th)	1	
11	0498 17 422	Gate, Shift (3rd & 4th)	1	
12	3648 17 431	Rod, Shift (Over Top & Reverse)	1	
13	3648 17 432	Gate, Shift (Over Top & Reverse)	1	
14	0821 17 435	Ring, Snap	2	
15	0221 17 441	Plug, Cap-Spring	2	
16	0259 17 441	Plug, Cap-Spring	1	
17	99562 1400	Gasket, Cap Plug	3	
18	99564 1000	Gasket, Cap Plug	1	
19	99611 2500	Ball, Steel	4	

MANUAL T/MISSION
(CHANGE CONTROLS, 5 SPEED)

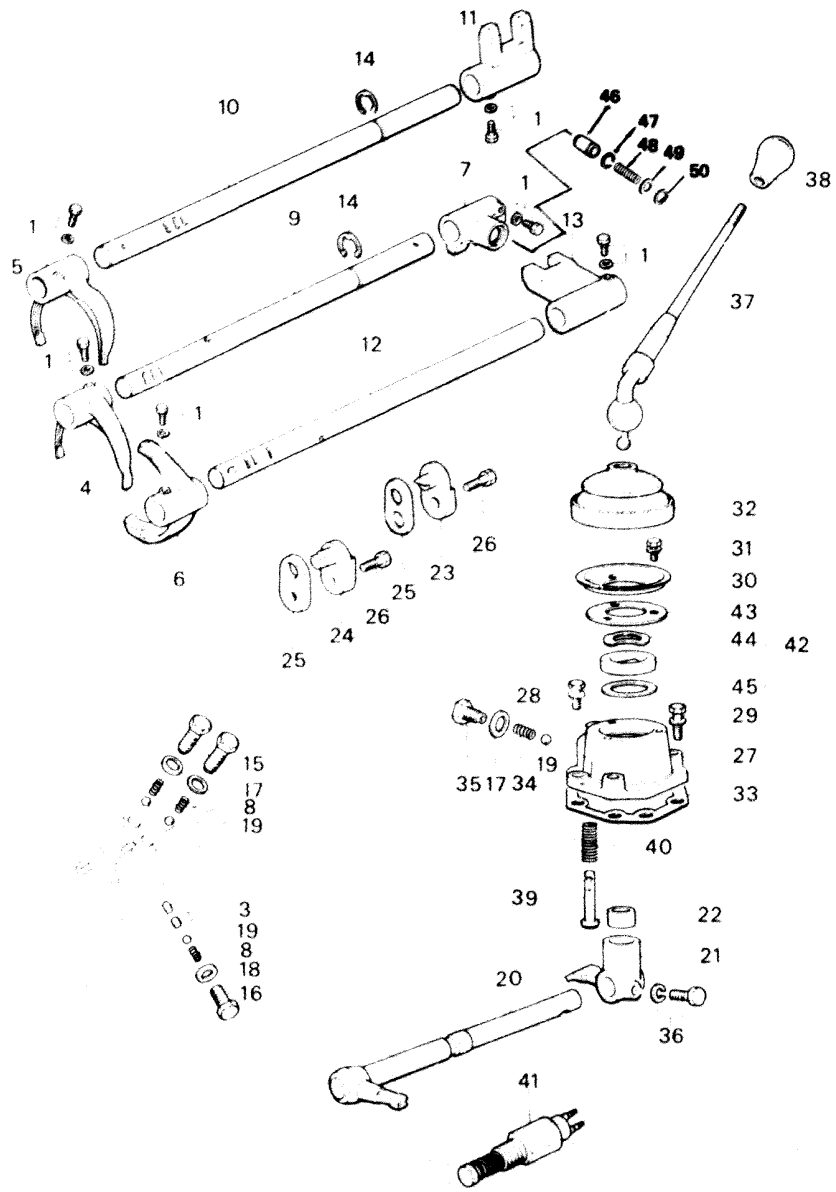

MANUAL T/MISSION
(CHANGE CONTROLS, 5 SPEED)

No.	Part Number	Description	Q'ty	Remarks
20	3778 17 450A	Lever, Control	1	
21	8601 17 461	End, Control Rod	1	
22	0398 17 462A	Seat, Spring	1	
23	3648 17 463	Pin, Stopper	1	
24	3648 17 464	Pin, Stopper	1	76/10 ~ Δ
25	3648 17 465	Gasket, Stopper Pin	2	
26	99796 0816	Bolt, Stopper Pin	2	
27	0498 17 470	Case, Change Control	1	
28	99796 0822	Bolt, Change Control Case	2	
29	99796 0832	Bolt, Change Control Case	2	
30	0647 17 473	Plate, Cover	1	
31	99796 0612	Bolt, Cover Plate	3	
32	0862 17 475	Boot, Dust	1	
33	0271 17 478	Gasket, Change Control Case	1	
34	0824 17 483	Spring	1	
35	0183 17 491	Plug, Cap-Spring	1	
36	0118 17 313	Bolt, Reamer - Control Rod End	1	
	99971 0601	Washer, Spring	1	
37	3794 17 510	Lever, Change	1	
38	1274 17 520	Knob, Change Lever	1	

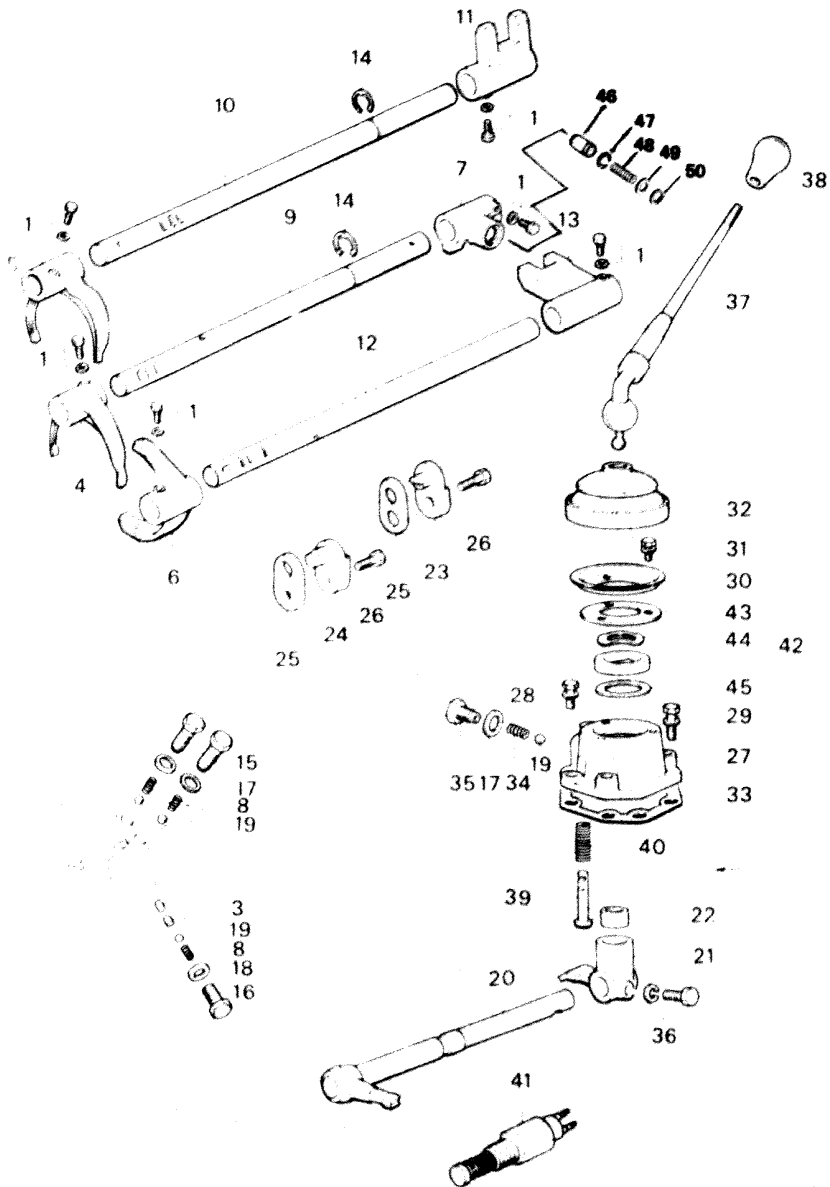

No.	Part Number	Description	Q'ts	Remarks
39	3648 17 551 A	Spindle, Select Lock	1	
40	0221 17 552	Spring Select Lock Spindle	1	
41	0821 17 505 A	Switch, Reverse Lamp	1	
42	0305 99 178	Change Bush Set	1	
43	0303 17 474	Gasket Cover Plate	1	
44	0303 17 482	Washer Wave	1	
45	99963 3310	Shim (t. 0.1)	3	Selective use
	99963 3330	Shim (t. 0.3)	1	
46	3648 17 414	Pin, Bush	1	
47	3648 17 415	Ring, Retaining	1	
48	3648 17 416	Spring	1	
49	99574 1300	Ring, Snap	1	
50	99952 0412	Washer, Plain	1	

DISTRIBUTOR

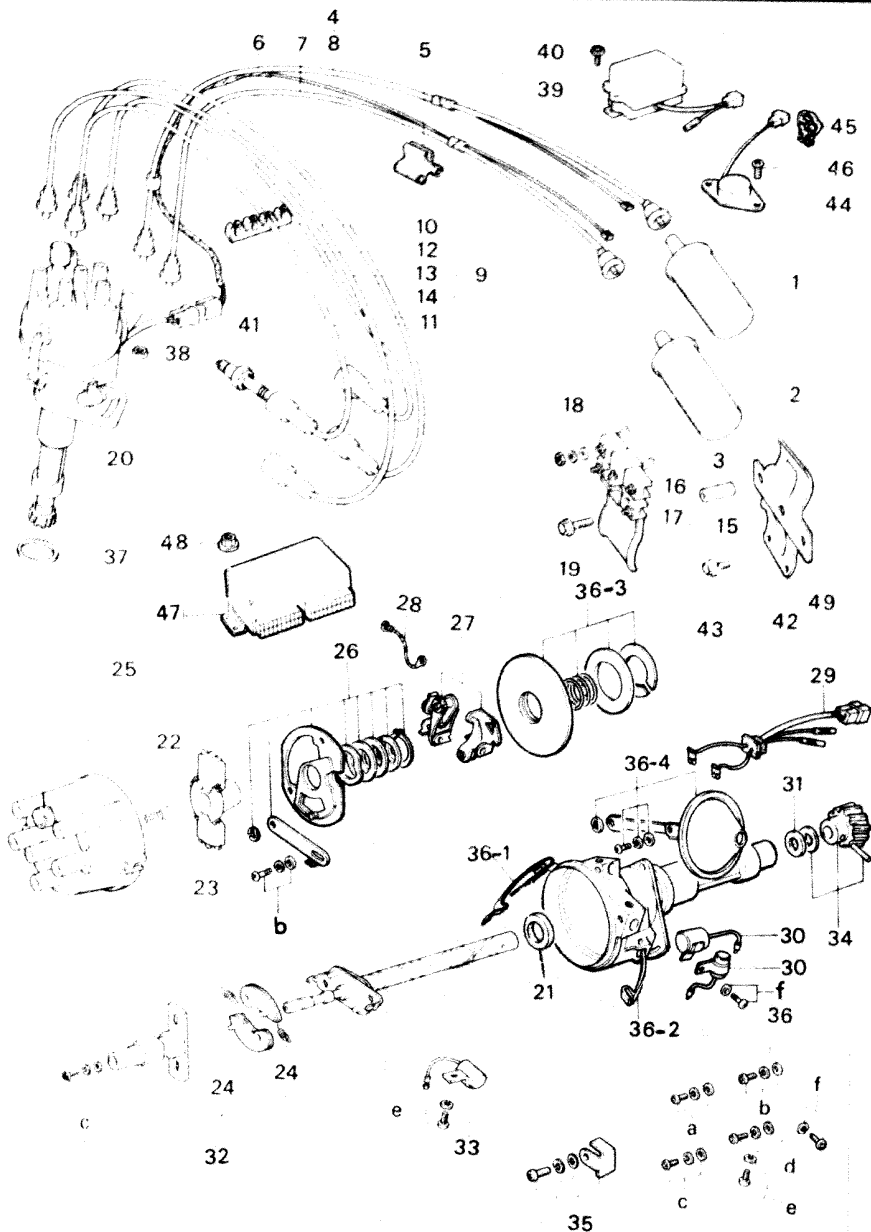

DISTRIBUTOR

No.	Part Number	Description	Qty	Remarks
1	1562 18 100 A	Coil, Ignition	1	
2	1672 18 100 A	Coil, Ignition HP 5 13J	1	
3	0823 18 107	Pipe	1	
4	3790 18 110 A	Cord, High Tension	1	
5	3648 18 111	Supporter, High Tension Cord	1	
6	3790 18 115	Cord	1	
7	1854 18 120	Cord, High Tension (Trailing)	1	
8	1854 18 160	Cord, High Tension (Leading)	1	
9	1757 18 150 D	Cord, High Tension	1	
10	0820 18 114	Supporter, High Tension Cord	1	
11	1757 18 130 A	Cord, High Tension (T 1)	1	
12	1757 18 140 B	Cord, High Tension (T 2)	1	
13	1757 18 170 A	Cord, High Tension (L 1)	1	
14	1757 18 180 A	Cord, High Tension (L 2)	1	
15	3648 18 190	Bracket, Ignition Coil	1	

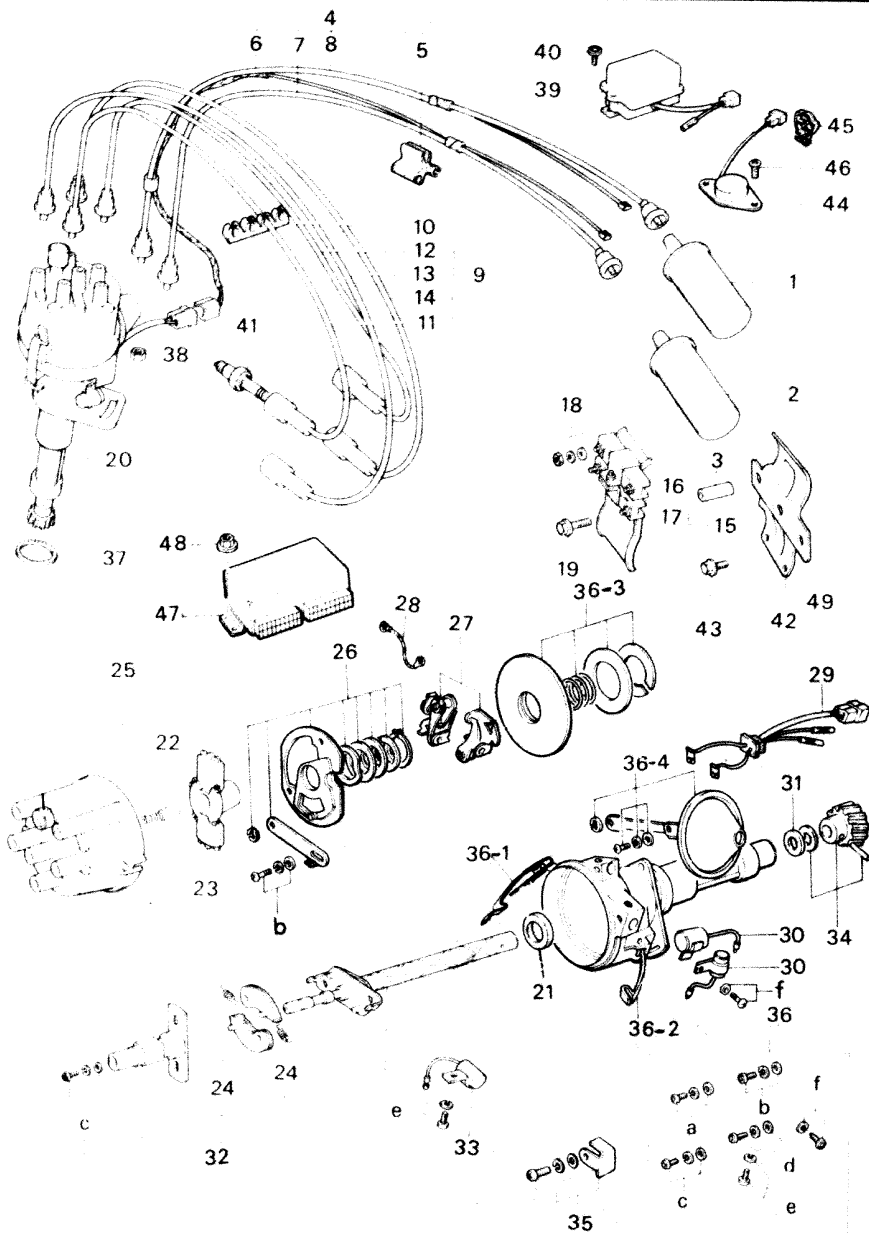

No.	Part Number	Description	Qty	Remarks
• 18	0845 18 101	Resistor	1	
• 16	0578 18 101	Resistor	1	From Car No. 1
17	3648 18 101	Resistor	1	
18	99906 0500	Nut, Ignition Coil & Resistor Terminal	6	
	99952 0500	Washer, Plain	6	
	99971 0500	Washer, Spring	6	
19	99786 0850	Screw, Ignition Coil Bracket	1	
20	3790 18 200	Distributor	1	
21	0107 18 216A	Oil Seal	1	
22	1757 24 302	Contact	1	
23	3648 24 303	Rotor	1	
24	8735 24 308	Spring Set	1	
25	1757 24 310	Cap	1	
26	8735 24 313	Base, Breaker	1	
27	1757 24 314	Support, Arm	2	
28	1757 24 317	Wire (E), Lead	1	
• 29	8735 24 319	Wire, Lead	1	

DISTRIBUTOR

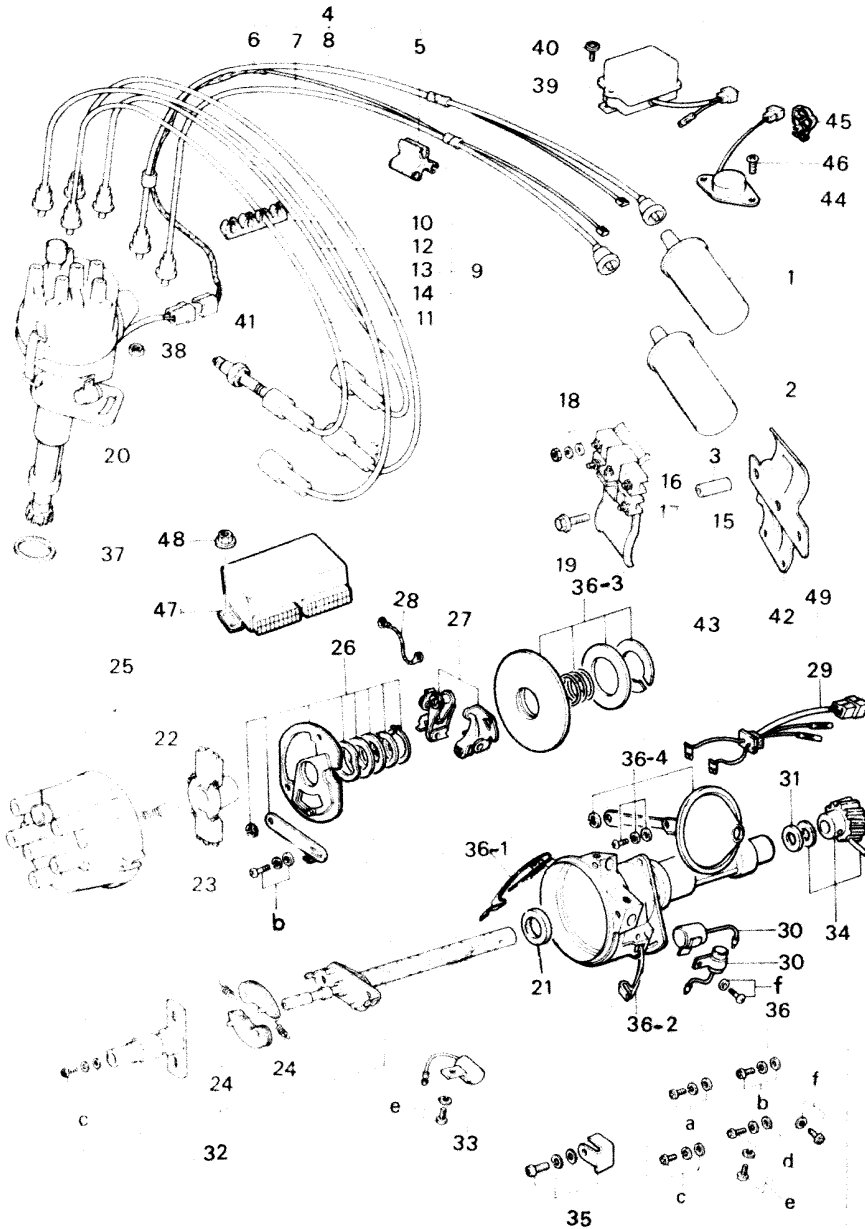

DISTRIBUTOR

No.	Part Number	Description	Qty	Remarks
30	1757 24 322	Condenser	2	
31	1757 24 328	Gasket	1	
32	8735 24 330	Governor Set	1	
33	1757 24 334	Condenser	1	
34	3648 24 340	Coupling Set	1	
35	3775 24 350	Holder Set	1	
36	8650 24 351	Screw Set	1	
36-1	3648 24 304	Clamp	1	
36-2	3648 24 305	Clamp	1	
36-3	3648 24 323	Base Assy, Breaker	1	
36-4	3790 24 351	Vacuum Set	1	
37	99541 0350	Ring, "O" - Distributor	1	
38	99940 0603	Nut, Distributor	1	
39	0453 18 391	Regulator	1	
40	99786 0612	Bolt	2	
	99971 0600	Washer, Spring	2	
41	3743 18 600	Plug, Spark NGK MAKE (B7ET)	4	
			4	
			4	
42	3648 18 810	Bracket, Ignition Coil	1	
43	99786 0612	Screw, Bracket	2	
44	1259 18 890	Switch, Thermo	1	
45	1011 67 911	Clip	1	

DISTRIBUTOR

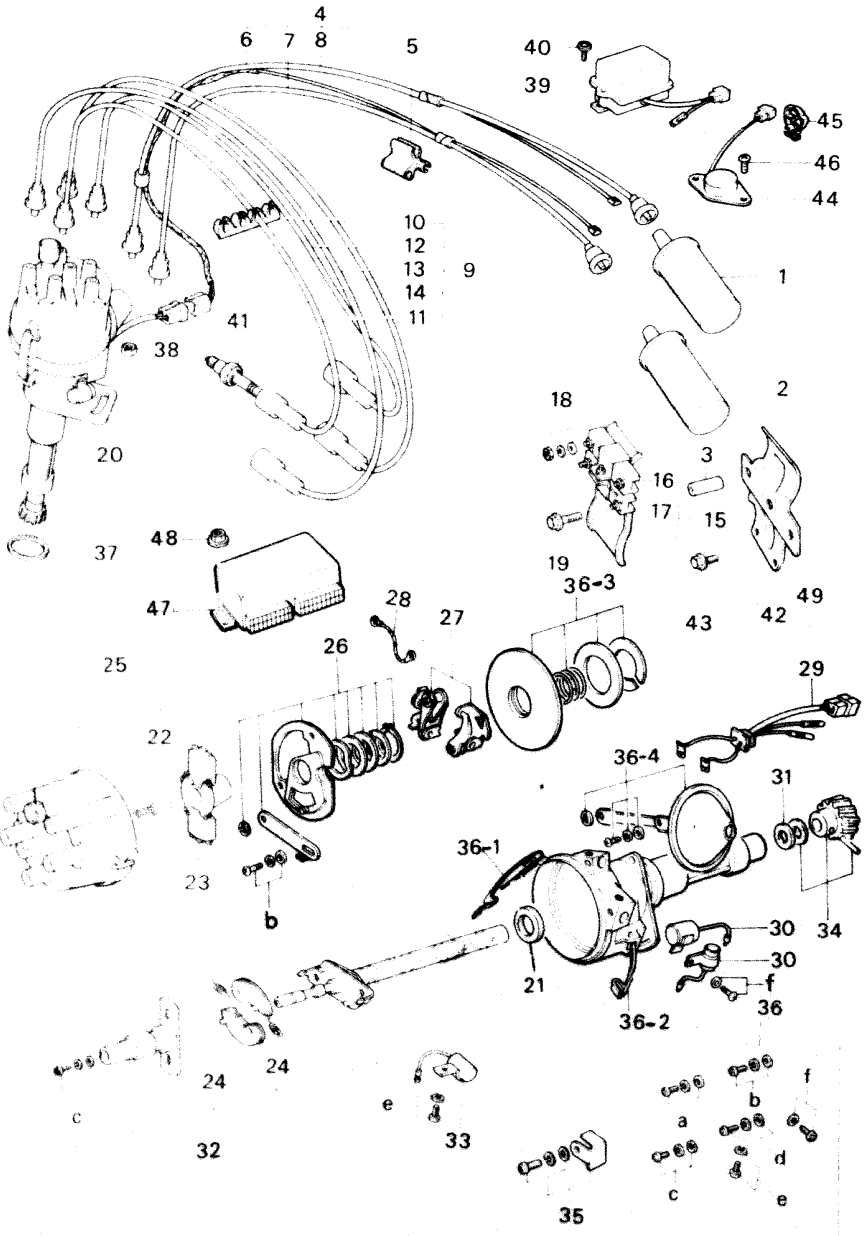

DISTRIBUTOR

No.	Part Number	Description	Q'ty	Remarks
46	99865 0510	Screw	2	
47	8712 18 940B	Control Unit (Fed.)	1	
	8735 18 940A	Control Unit (Calif. Manual)	1	
	8736 18 940A	Control Unit (Calif. Automatic)	1	
48	99940 0600	Nut, Control Unit	2	
49	1811 72 618	Spring, Rubber	3	

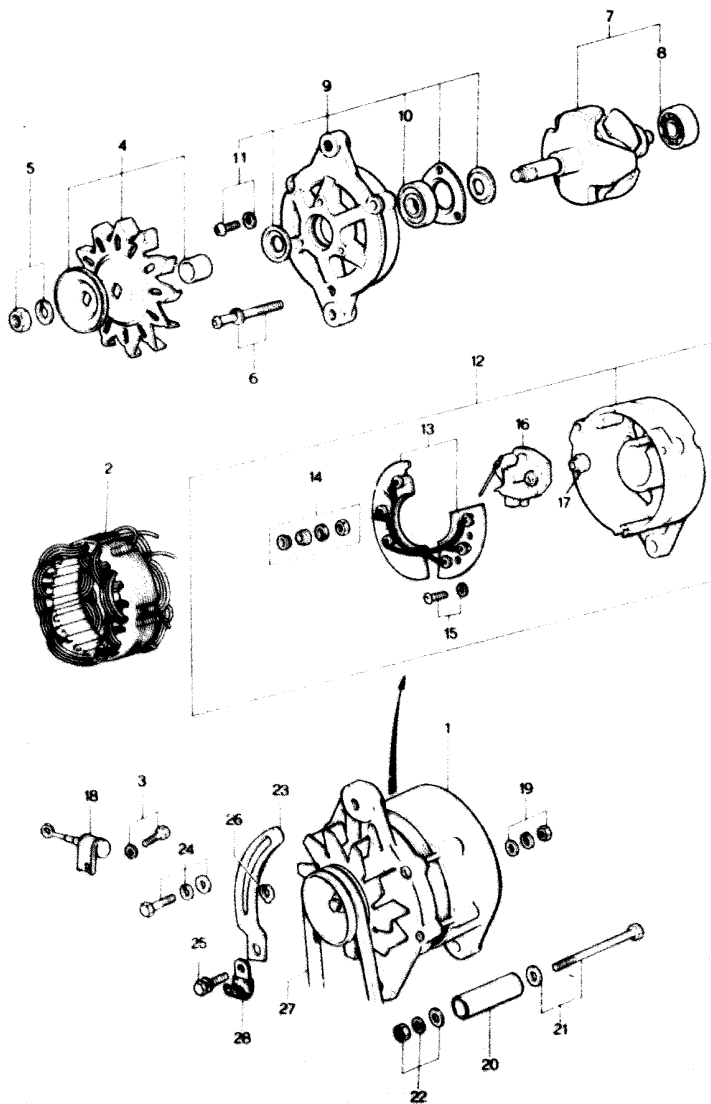

No.	Part Number	Description	Q'ty	Remarks
1	1011 18 300	Alternator	1	
2	1011 24 501	Stator	1	
3	1011 24 527	Screw	1	
4	0866 24 530	Pulley	1	
5	0866 24 533	Nut Set	1	
6	0866 24 535	Screw Set	1	
7	0866 24 540A	Rotor (Fig. No. 8 included)	1	
8	0820 24 503	Bearing	1	
9	0866 24 550	Bracket, Front (Fig. No. 10 & 11 included)	1	
10	0208 24 514	Bearing	1	
11	0866 24 526	Screw	3	
12	1011 24 560	Bracket, Rear (Fig. No. 13 ~ 17 included)	1	
13	1011 24 510	Rectifier Ass'y	1	
14	1011 24 533	Nut Set	1	
15	1011 24 534	Screw	1	
16	1011 24 541	Holder, Brush	1	
17	1011 24 563	Mould	1	
18	8028 24 581	Condenser	1	
19	99906 0500	Nut, Alternator Terminal	1	

ALTERNATOR

ALTERNATOR

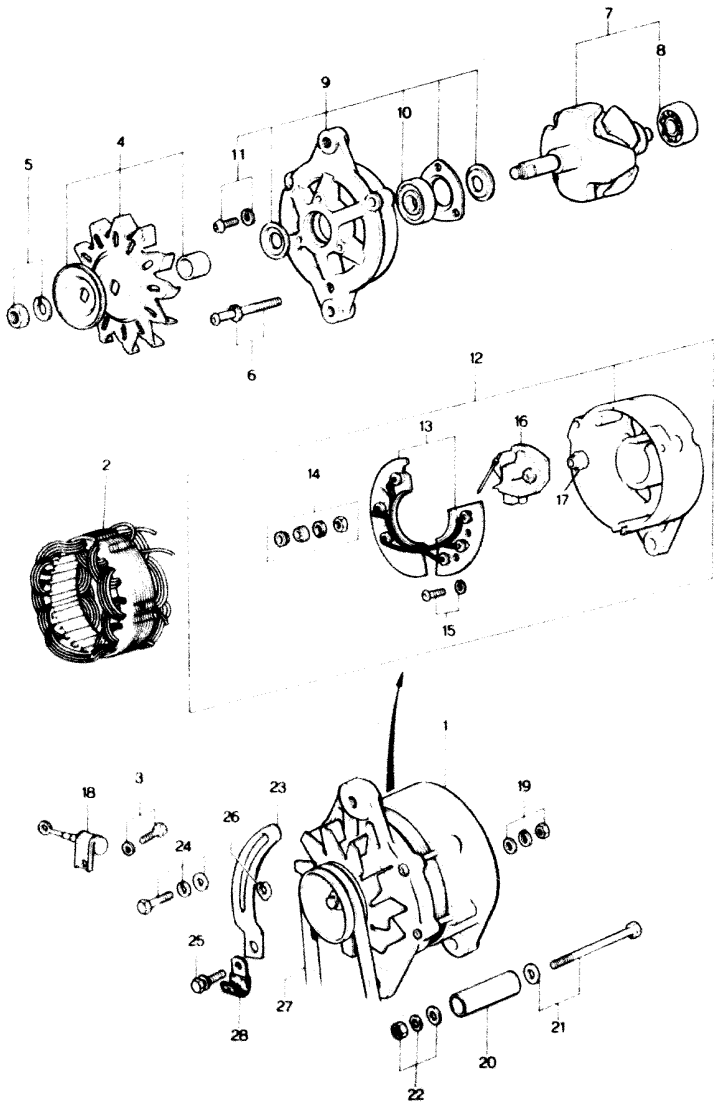

No.	Part Number	Description	Q'ty	Remarks
	99952 0500	Washer, Plain	1	
	99971 0500	Washer, Spring	1	
20	1757 18 311	Bracket, Alternator	1	
21	99800 10115	Bolt, Alternator	1	
22	99940 1001	Nut, Alternator	1	
23	1881 18 361A	Strap, Alternator	1	
24	99796 0825	Bolt, Strap	1	
25	99796 0820	Bolt, Strap	1	
	99952 0822	Washer, Plain	1	
26	0222 18 375	Shim (t = 0.3)	Selective use	1
	0222 18 376	Shim (t = 0.5)		
	0222 18 377	Shim (t = 0.7)		
27	1672 18 381A	Belt, "V"	1	
28	99276 2008	Clip, Wire Harness	1	

STARTER & BATTERY

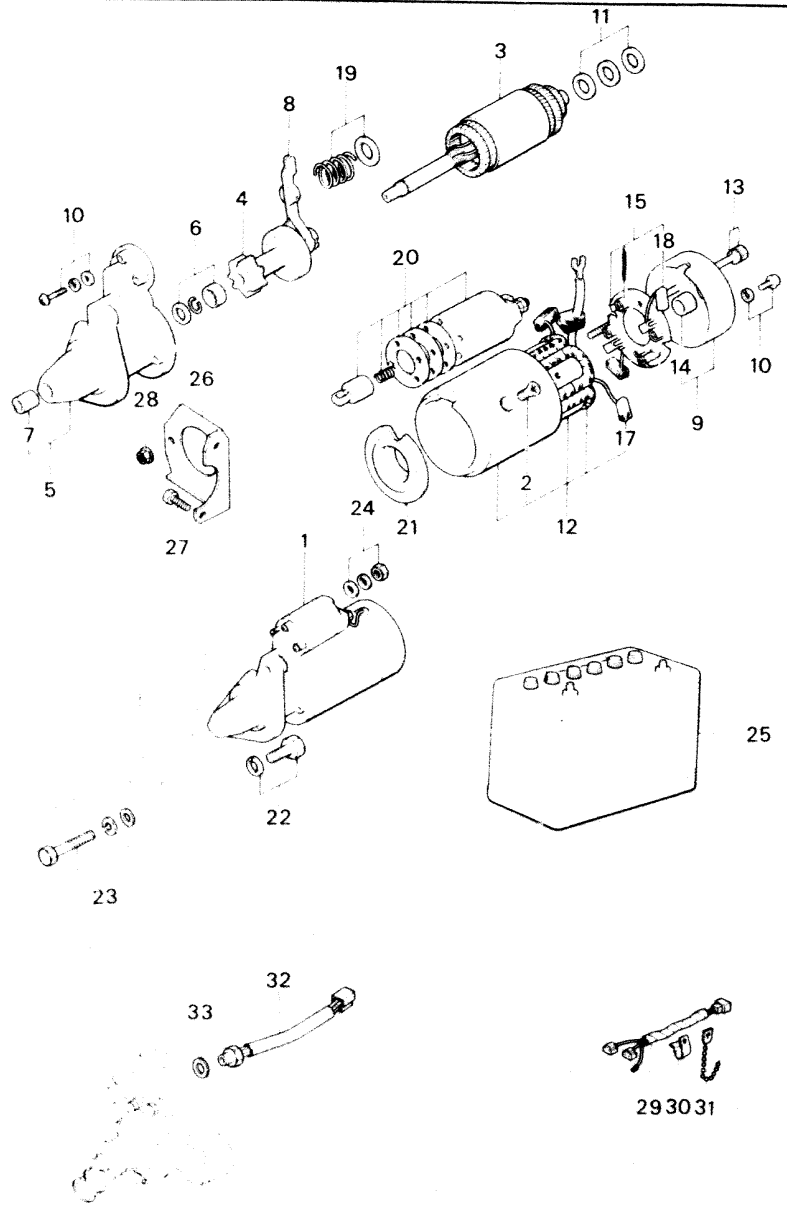

STARTER & BATTERY

No.	Part Number	Description	Q'ty	Remarks
1	1757 18 400C	Starter (Manual)	1	
•	1757 18 400D	Starter (Manual)	1	77/12 ~ Δ
	1758 18 400C	Starter (Automatic)	1	
2	0866 24 704	Screw (Automatic)	4	
3	3648 24 705	Armature (Manual)	1	
	1758 24 705	Armature (Automatic)	1	
4	1757 24 709	Clutch, Over Running (Automatic)	1	
	3648 24 709	Clutch, Over Running (Manual)	1	
5	1757 24 710B	Bracket, Front (Manual)	1	
•	1757 24 710C	Bracket, Front (Manual)	1	77/12 ~ Δ
	1758 24 710A	Bracket, Front (Automatic)	1	
6	0426 24 712	Stopper Set, Piston	1	
7	0426 24 715A	Sleeve	1	
8	0866 24 716	Lever (Automatic)	1	
	0222 24 730	Lever (Manual)	1	
9	0845 24 720	Bracket, Rear (Automatic)	1	
	0222 24 740	Bracket, Rear (Manual)	1	
10	0426 24 725	Screw Set	1	
11	0426 24 726	Washer Set (Manual)	1	
	1758 24 726	Washer Set (Automatic)	1	
12	1757 24 730A	Yoke (Manual)	1	
	1758 24 730B	Yoke (Automatic)	1	
13	0426 24 731	Bolt Set (Manual)	1	
	1758 24 731A	Bolt Set (Automatic)	1	

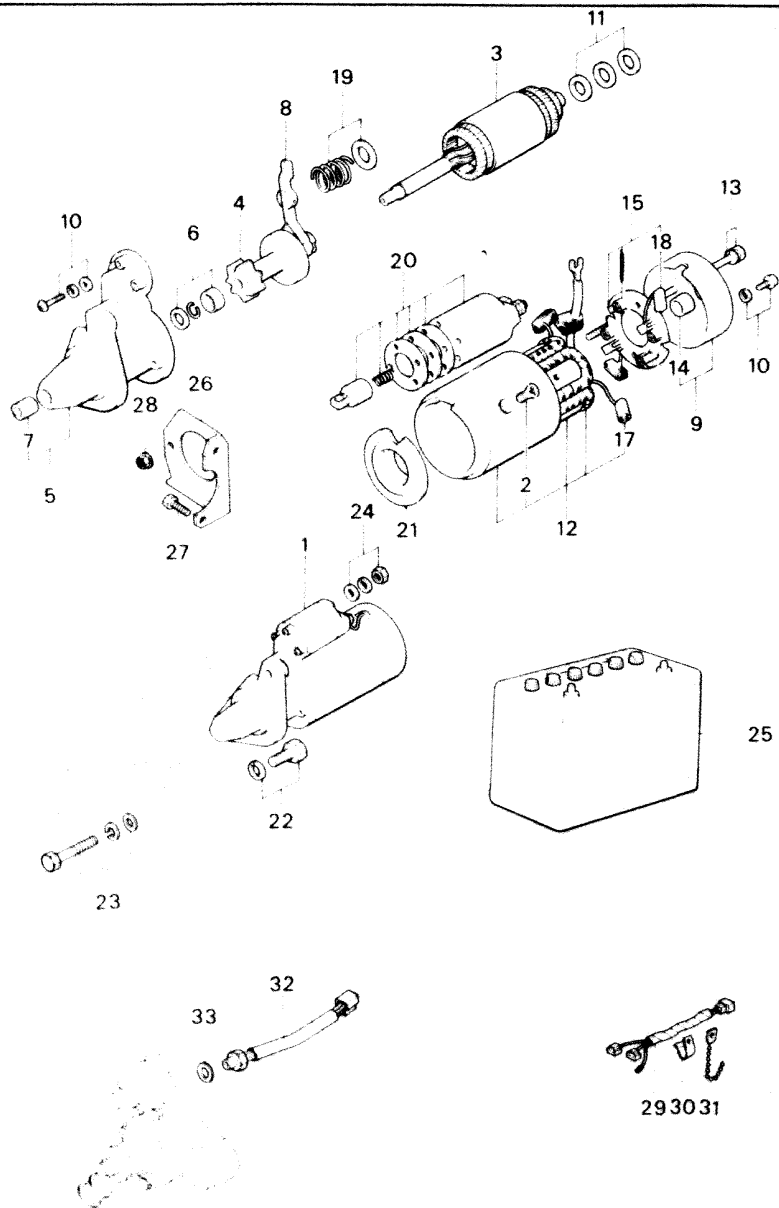

No.	Part Number	Description	Q'ty	Remarks
14	0222 24 741	Sleeve	1	
15	1758 24 750	Holder	1	
16	0222 24 752 A	Spring, Brush (Manual)	4	
17	0222 24 753	Brush (Manual)	2	
18	0426 24 753	Brush (Automatic)	2	
19	0426 24 754	Spring Set	1	
20	1757 24 760	Switch, Starter (Manual)	1	
	1758 24 736	Switch, Starter (Automatic)	1	
21	1758 24 706	Bracket, Center (Automatic)	1	
22	99801 1032	Bolt, Starter	1	
23	99803 10120	Bolt, Starter (Manual)	1	
	99801 1075	Bolt, Starter (Automatic)	1	
	99953 1000	Washer, Plain	1	
	99971 1000	Washer, Spring	1	
24	99901 0800	Nut, Starter Terminal	1	
	99952 0800	Washer, Plain	1	
	99971 0800	Washer, Spring	1	
25	1620 18 520	Battery (NIZ) G.S. Make Selective use	1	

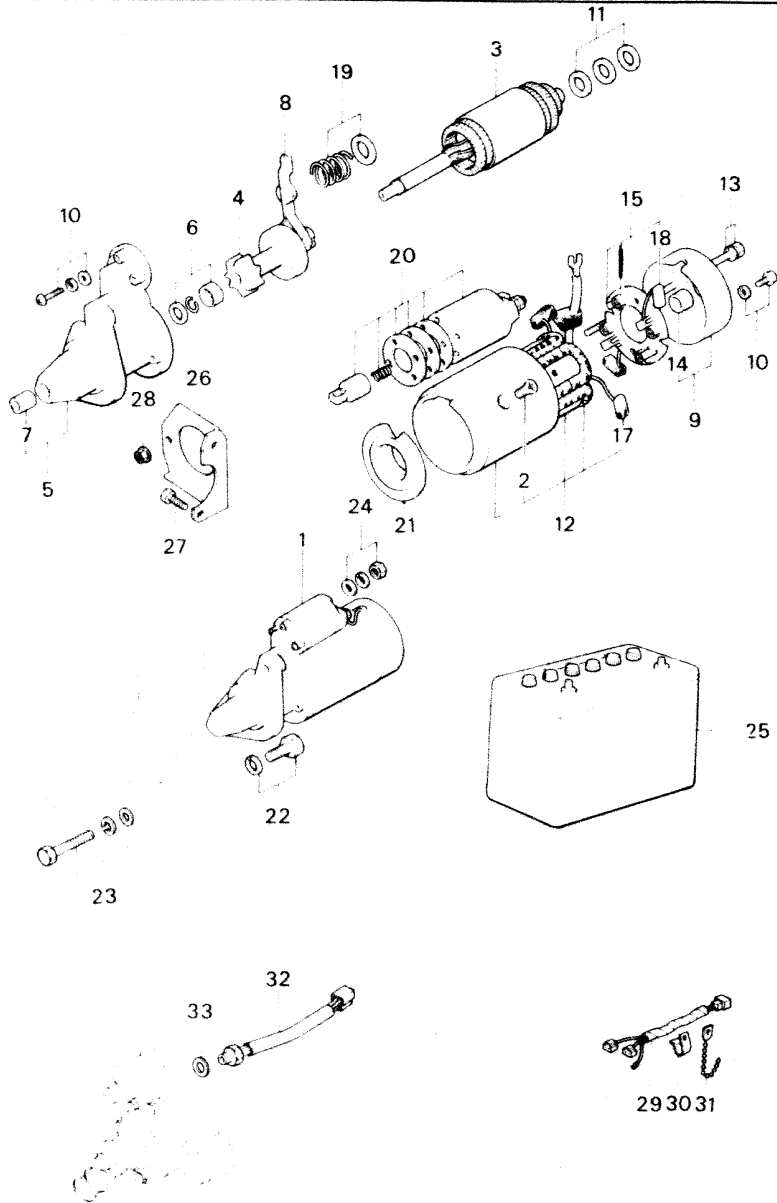

No.	Part Number	Description	Q'ty	Remarks
	8715 18 520	Battery (NS70S) (Fed. Automatic)	1	
	0504 18 520B	Battery (G60) (Except Fed. Automatic)	1	
26	1758 18 401 A	Stay, Starter	1	
27	99796 0610	Boit, Stay (Automatic)	2	
28	99940 0602	Nut	1	
29	3648 18 860	Wiring, Valve	1	
30	3648 18 861 A	Clip, Valve Wiring	1	
31	99709 0108	Band, Valve Wiring	1	
32	1881 18 880A	Switch, Temperature	1	
33	99564 1600	Gasket	1	

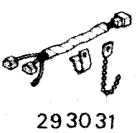

293031

**AUTOMATIC T / MISSION
(CONVERTER, OIL PUMP & PIPING)**

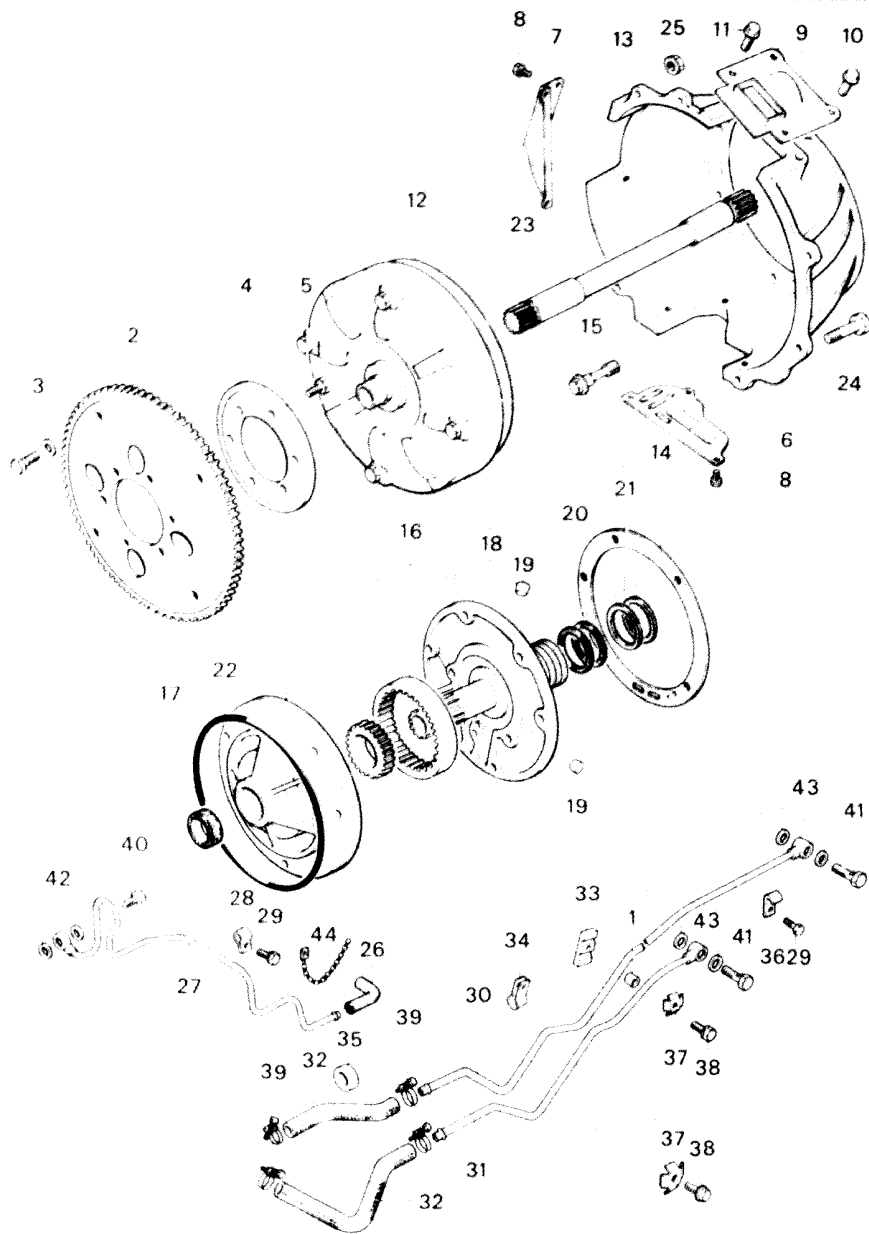

**AUTOMATIC T / MISSION
(CONVERTER, OIL PUMP & PIPING)**

No.	Part Number	Description	Q'ty	Remarks
1	2850 13 331	Spacer, Oil Pipe	1	
2	1758 19 020	Plate, Drive	1	
3	3649 19 064	Bolt, Drive Plate	4	
4	0842 19 025	Plate, Backing	1	
5	99784 1016	Bolt, Backing Plate	6	
6	1908 19 027	Cover, Under	1	
7	0454 19 028A	Cover, Side	1	
8	99796 0610	Bolt, Under & Side Cover	7	
9	1758 19 026	Cover, Top	1	
10	99796 0610	Bolt, Top Cover	1	
11	99796 0816	Bolt, Top Cover	2	
12	8501 19 100	Converter, Torque	1	
13	1758 19 211B	Housing, Converter	1	
14	1758 19 215	Gasket, Oil Pump	1	
15	0338 19 216	Bolt, Housing	6	
16	1758 19 220	Pump, Oil	1	
17	0338 19 223	Oil Seal	1	
18	1758 19 240	Cover	1	

**AUTOMATIC T/MISSION
(CONVERTER, OIL PUMP & PIPING)**

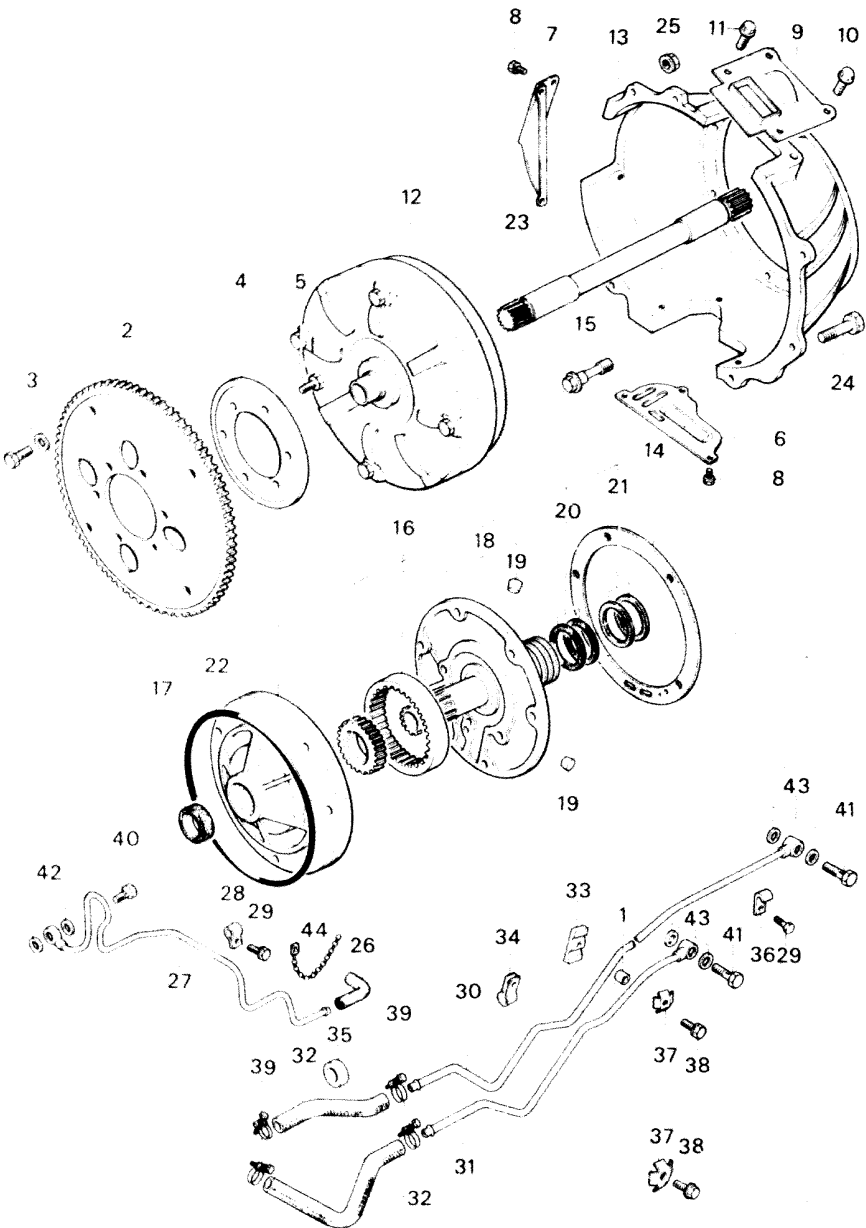

**AUTOMATIC T/MISSION
(CONVERTER, OIL PUMP & PIPING)**

No.	Part Number	Description	Qty	Remarks
19	0338 19 245A	Ball	2	
20	0338 19 256	Ring, Seal	2	
21	0338 19 257	Ring, Seal	2	
22	0338 19 258	Seal, Lathe Cut Ring	1	
23	0338 19 678	Shaft, Input	1	
24	99796 1035	Bolt, Housing	2	
	99796 1050	Bolt	1	
	99796 1045	Bolt	1	
25	99940 1001	Nut, Housing	1	
26	0338 19 904A	Hose, Vacuum (Rr.)	1	
27	0808 19 910	Pipe, Vacuum	1	
28	0842 19 915A	Clip, Vacuum Pipe	2	
29	99796 0610	Bolt, Clip	3	
30	1053 19 920B	Pipe, Oil	1	
31	1053 19 930B	Pipe, Oil	1	
32	1015 19 934C	Hose, Oil	2	
33	1015 19 945A	Plate, Spacer	1	
34	2579 19 989	Clip, Pipe	1	
35	1098 19 939	Guide, Oil Hose	1	

**AUTOMATIC T /MISSION
(CONVERTER, OIL PUMP & PIPING)**

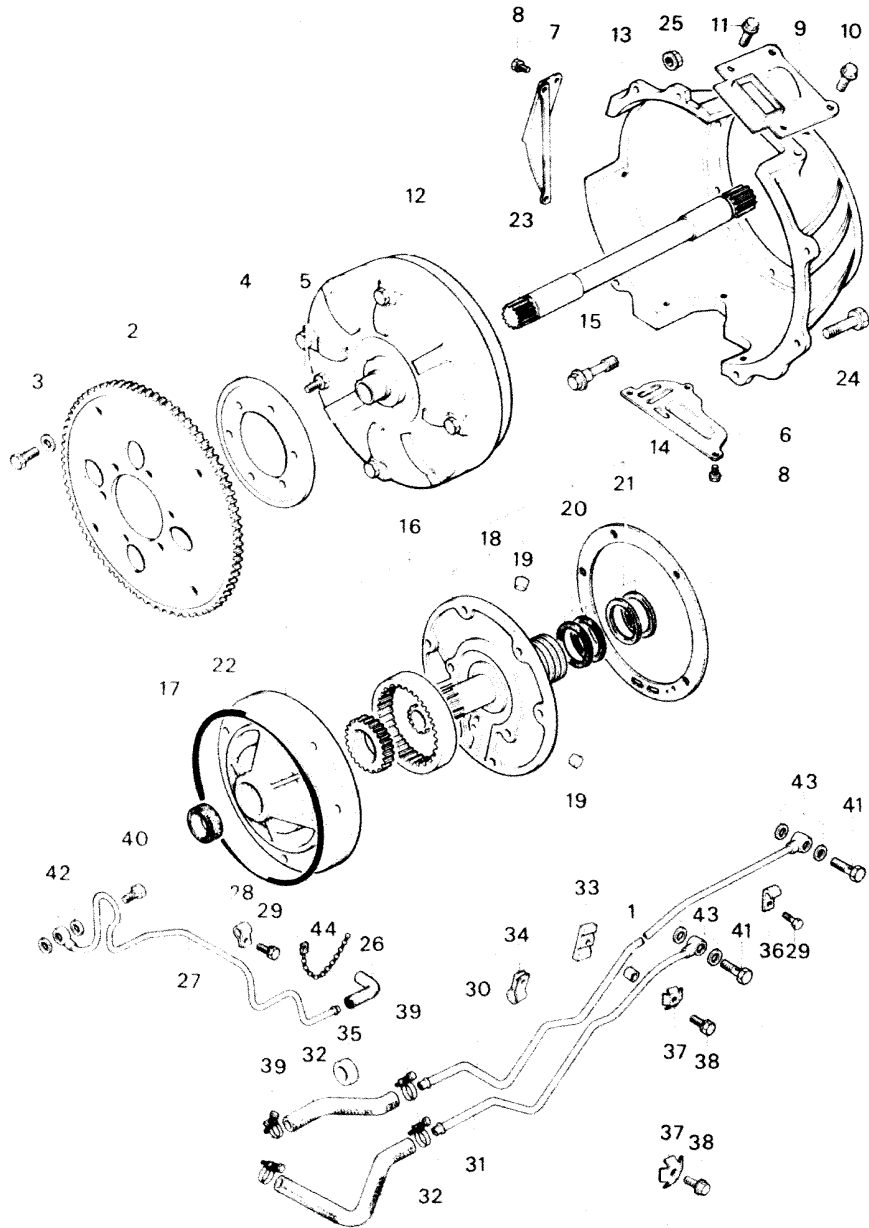

**AUTOMATIC T /MISSION
(CONVERTER, OIL PUMP & PIPING)**

No.	Part Number	Description	Q'ty	Remarks
36	99276 1C06	Clip. Pipe	1	
37	0866 45 903A	Clip. Pipe	2	
38	99796 0620	Bolt. Clip	2	
39	99282 1700	Band. Hose	4	
40	99381 0600	Bolt. Connector - Vacuum Pipe	1	
41	99381 0800	Bolt. Connector - Oil Pipe	2	
42	99564 1000	Gasket. Connector Bolt	2	
43	99564 1200	Gasket. Connector Bolt	4	
44	99709 0108	Band. Oil Pipe	1	
3649	19 090A	T /mission Cpt.	1	

AUTOMATIC T/MISSION (CASE & MAIN CONTROL)

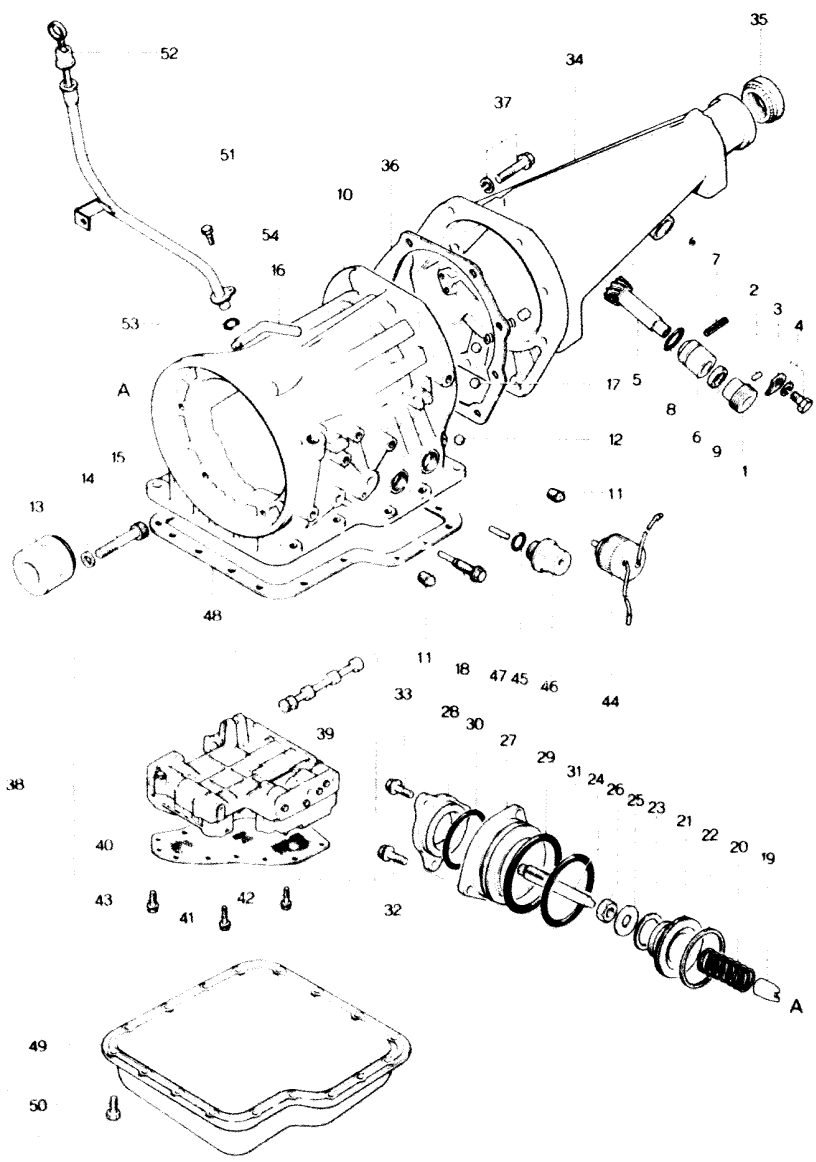

AUTOMATIC T/MISSION (CASE & MAIN CONTROL)

No.	Part Number	Description	Q'ty	Remarks
1	0862 17 351	Joint, Cable - Speedometer	1	
2	0187 17 352	Pin, Dowel - Driven Gear	1	
3	0111 17 354	Plate, Lock - Cable Joint	1	
4	99796 0612	Bolt, Lock Plate	1	
5	3790 17 441	Gear, Driven - Speedometer	1	
6	0862 17 442	Sleeve, Speedometer Driven Gear	1	
7	99222 0216	Pin, Spring	1	
8	99541 02211	Ring, "O" - Driven Gear	1	
9	99586 10207	Oil Seal, Driven Gear	1	
10	1181 19 310B	Case, T/mission	1	
11	0338 19 331A	Plug, Square Head	2	
12	99611 1750	Ball, Steel	3	
13	0338 19 336	Race, Inner	1	
14	0338 19 337	Washer, Plain	8	
15	0338 19 338	Bolt	8	
16	0378 19 344	Breather, Air	1	
17	99611 2000	Ball, Steel	3	
18	1758 19 341	Bolt, Anchor End	1	

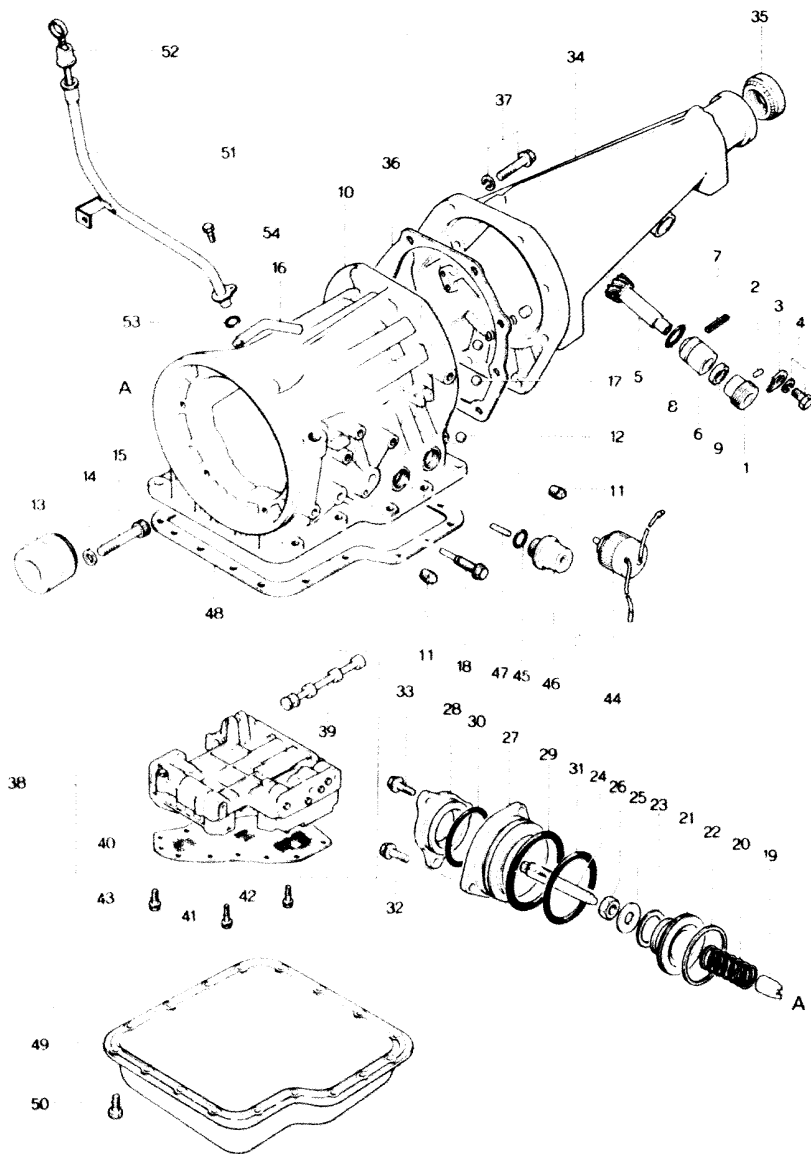
**AUTOMATIC T/MISSION
(CASE & MAIN CONTROL)**

**AUTOMATIC T/MISSION
(CASE & MAIN CONTROL)**

No.	Part Number	Description	Q'ty	Remarks
19	0338 19 361	Strut, Band	1	
20	0338 19 363	Spring, Return - Piston	1	
21	0842 19 381	Piston, Band Servo	1	
22	0338 19 384	Seal, Piston	1	
23	0842 19 385	Seal, Piston	1	
24	1755 19 386	Stem, Piston	1	
25	0338 19 388A	Washer, Plain	1	
26	0338 19 389	Nut, Band Adjust	1	
27	1758 19 391A	Retainer, Servo	1	
28	1758 19 392A	Cover, Servo	1	
29	0842 19 394	Seal, Lathe Cut Ring	1	
30	1758 19 394A	Ring, "O"	1	
31	0338 19 395	Seal, "O" Ring	1	
32	0338 19 397	Bolt	3	
33	1758 19 397	Bolt, Servo	3	
34	1840 19 710	Housing, Extension	1	
35	0437 17 335	Oil Seal	1	
36	0338 19 735	Gasket, Extension Housing	1	

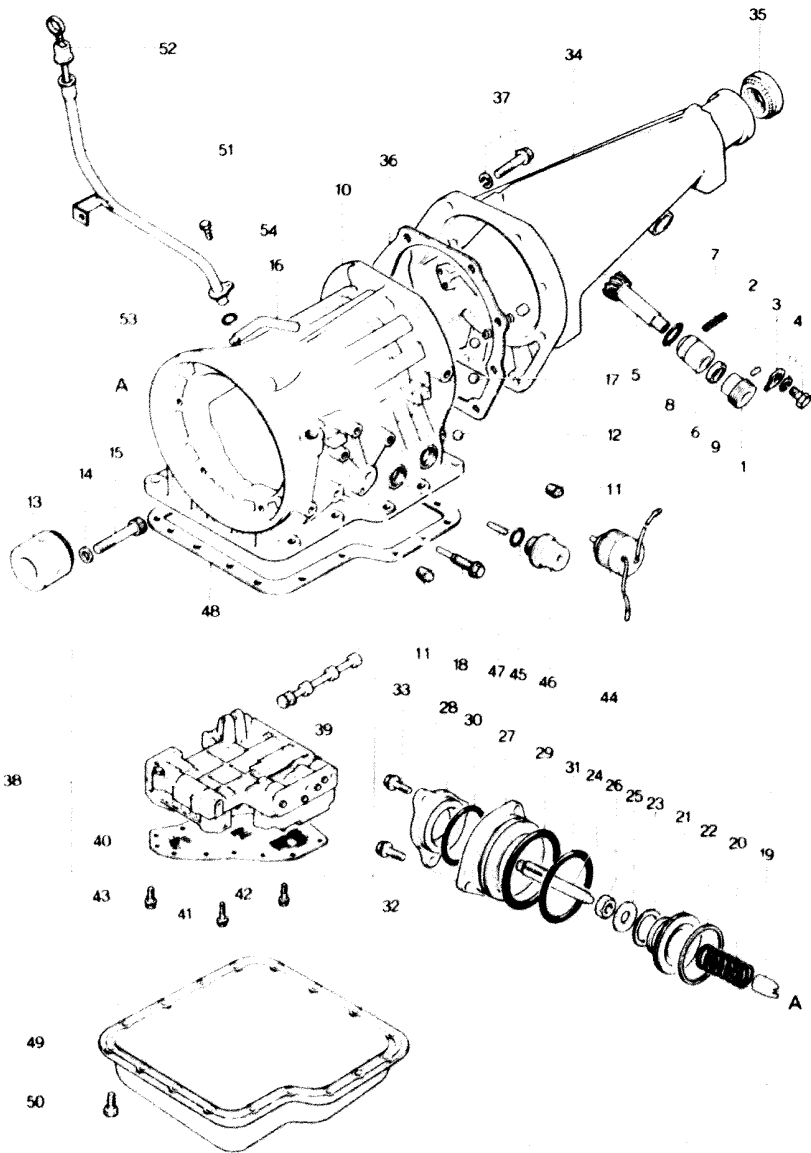
**AUTOMATIC T / MISSION
(CASE & MAIN CONTROL)**



**AUTOMATIC T / MISSION
(CASE & MAIN CONTROL)**

No.	Part Number	Description	Q'ty	Remarks
37	0338 19 737	Bolt, Extension Housing	8	
	0338 19 739	Washer, Plain	8	
38	3649 19 750	Valve, Control	1	
39	0338 19 768	Valve, Manual	1	
40	1758 19 815	Strainer, Oil	1	
41	0338 19 831	Bolt, Control Valve	4	
42	0338 19 832	Bolt, Control Valve	2	
43	0338 19 833	Bolt, Control Valve	3	
44	1675 19 821	Solenoid, Down Shift	1	
45	0338 19 822	Seal, "O" Ring	2	
46	1758 19 823	Diaphragm, Vacuum	1	
47	0338 19 825	Rod, Diaphragm (ℓ - 30.0)	1	Selective use
	0338 19 826	Rod (ℓ - 31.0)		
	0338 19 827	Rod (ℓ - 30.5)		
	0338 19 828	Rod (ℓ - 29.0)		
	0338 19 829	Rod (ℓ - 29.5)		
48	1758 19 835	Gasket, Oil Pan	1	

**AUTOMATIC T/MISSION
(CASE & MAIN CONTROL)**

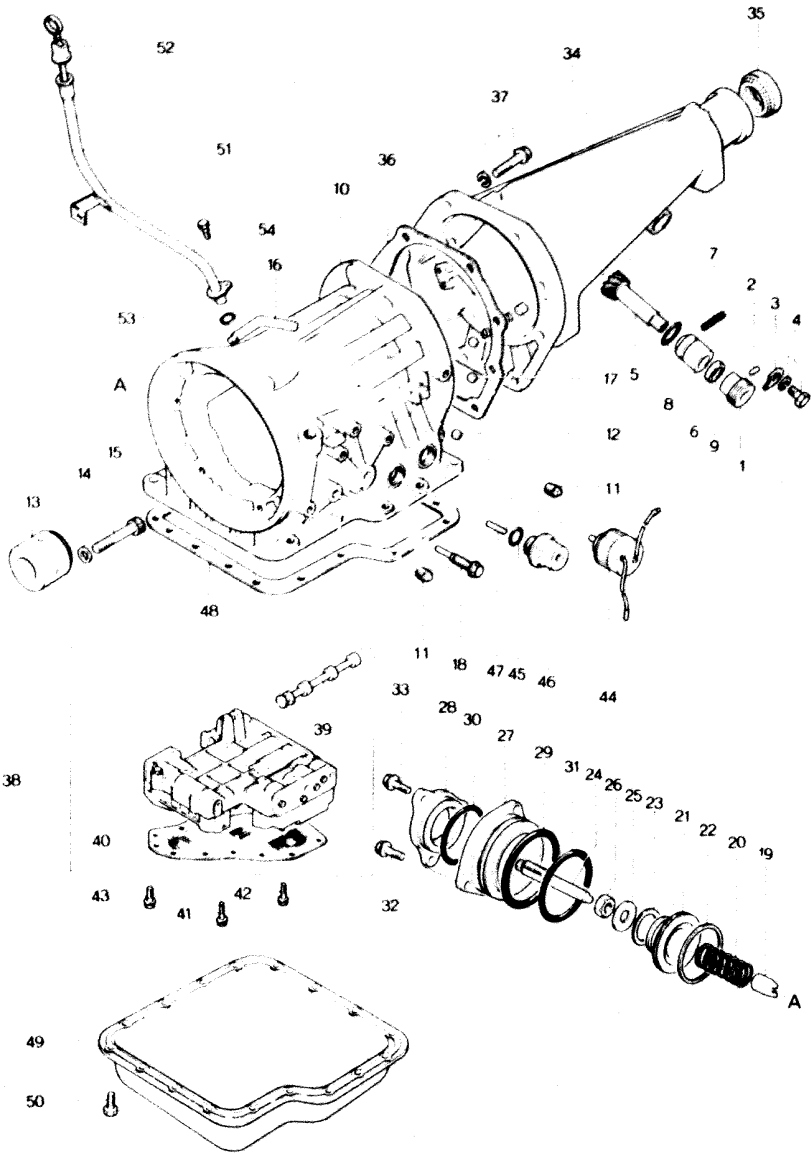

**AUTOMATIC T/MISSION
(CASE & MAIN CONTROL)**

No.	Part Number	Description	Qty	Remarks
49	1758 19 836	Pan. Oil	1	
50	0338 19 837	Bolt. Oil Pan	18	
51	1856 19 870A	Tube. Oil Level	1	
52	1758 19 980	Gauge. Oil Level	1	
53	99541 01601	Ring. "O"-Oil Level Tube	1	
54	99796 0610	Bolt. Oil Level Tube	1	

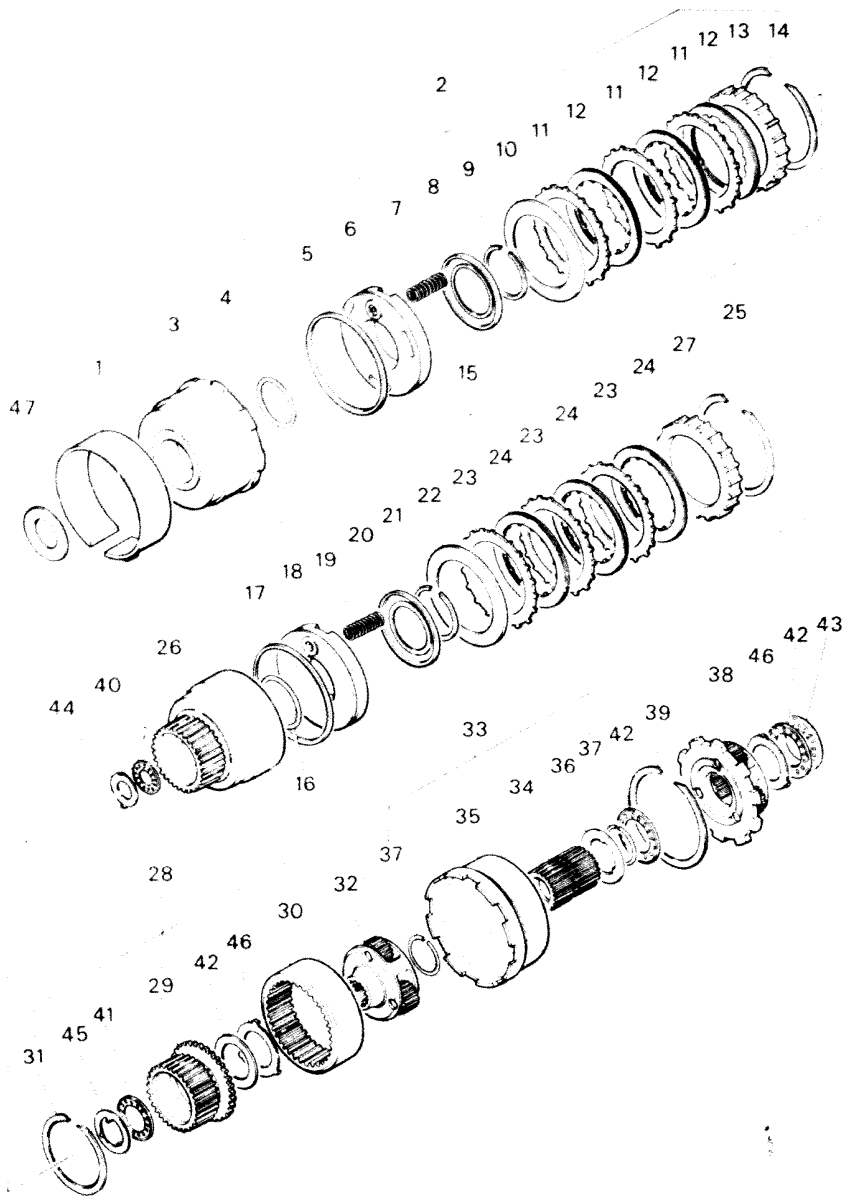

No.	Part Number	Description	Q'ty	Remarks
1	0338 19 360	Band, Brake	1	
•	0338 19 360A	Band, Brake	1	77/5 ~ 0
2	1758 19 460	Clutch, Front	1	
3	0338 19 470	Drum, Clutch	1	
4	0338 19 475	Seal, "O" Ring	1	
5	0338 19 476	Seal, Lathe Cut	1	
6	0338 19 480	Piston, Clutch	1	
7	0338 19 486	Spring, Piston Return	10	
8	0338 19 487	Retainer, Spring	1	
9	0338 19 488	Ring, Snap	1	
10	0338 19 498	Plate, Dished	1	
11	0338 19 499	Plate, Driven	4	
12	0338 19 500	Plate, Drive	4	
•	0338 19 500A	Plate, Drive	4	77/2 ~ 0
13	1758 19 503	Plate, Retaining	Selective use	1
	1758 19 504	Plate, Retaining		
	1758 19 505	Plate, Retaining		
	1758 19 506	Plate, Retaining		
	1758 19 507	Plate, Retaining		
	1758 19 508	Plate, Retaining		
	1758 19 509	Ring, Snap		

**AUTOMATIC T /MISSION
(CLUTCH & PLANETARY GEAR)**

**AUTOMATIC T /MISSION
(CLUTCH & PLANETARY GEAR)**

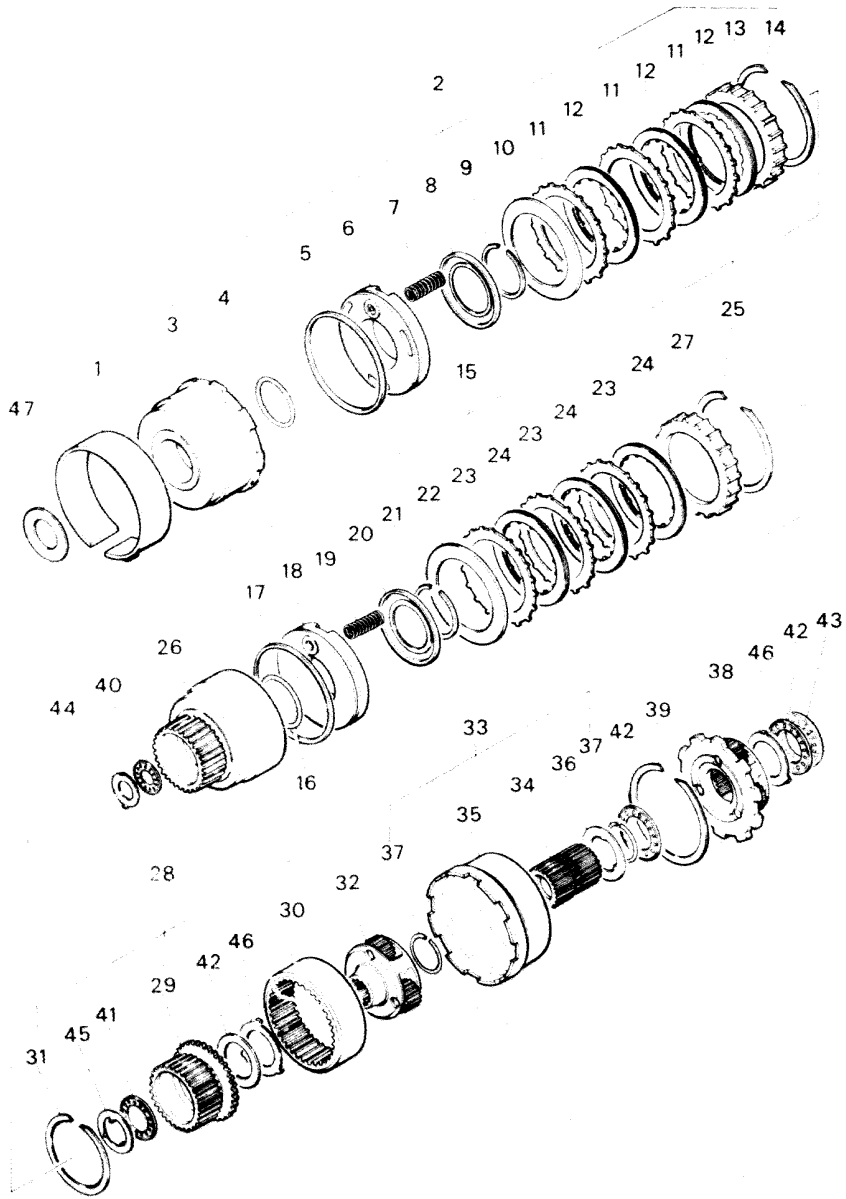

No.	Part Number	Description	Q'ty	Remarks
15	1758 19 510	Clutch, Rear	1	
16	0338 19 475	Seal, "O" Ring	1	
17	0338 19 476	Seal, Lathe Cut	1	
18	0338 19 480	Piston, Clutch	1	
19	0338 19 486	Spring, Piston Return	10	
20	0338 19 487	Retainer, Spring	1	
21	0338 19 488	Ring, Snap	1	
22	0338 19 498	Plate, Dished	1	
23	0338 19 499	Plate, Driven	5	
24	0338 19 500	Plate, Drive	5	
•	0338 19 500A	Plate, Drive	5	77/2 ~ 0
25	0338 19 509	Ring, Snap	1	
26	1758 19 511	Drum, Rear Clutch	1	
27	0378 19 515	Plate, Retaining	1	
28	0338 19 530	Hub, Rear Clutch	1	
29	0338 19 531	Hub, Rear Clutch	1	
30	0338 19 533	Gear, Internal	1	
31	0338 19 534	Ring, Snap	1	

AUTOMATIC T / MISSION (CLUTCH & PLANETARY GEAR)

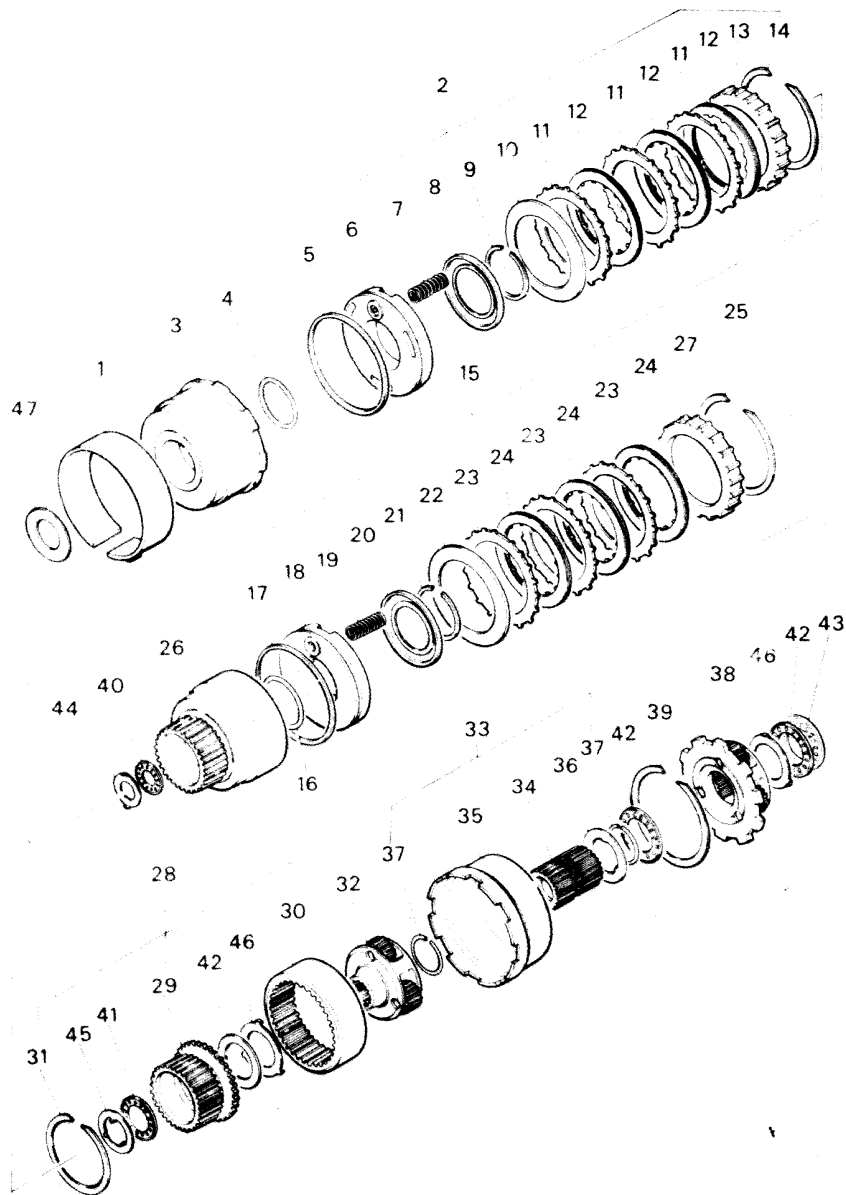

AUTOMATIC T / MISSION (CLUTCH & PLANETARY GEAR)

No.	Part Number	Description	Q'ty	Remarks
32	0338 19 540	Carrier, Front	1	
33	0338 19 550	Shell & Sun Gear	1	
34	0338 19 560	Gear, Sun	1	
35	0338 19 565	Shell, Connecting	1	
36	0338 19 566	Race, Bearing- Shell	1	
37	0338 19 567	Ring, Snap	2	
38	0338 19 570	Carrier, Rear	1	
39	0338 19 598	Ring, Snap	1	
40	0338 19 621	Bearing, Needle	1	
41	0338 19 622	Bearing, Needle	1	
42	0338 19 623	Bearing, Needle	3	
43	0338 19 624	Bearing, Needle	1	
44	0338 19 631	Race, Bearing (t=1.2)	Selective use 1	
	0338 19 632	Race, Bearing (t=1.4)		
	0338 19 633	Race, Bearing (t=1.6)		
	0338 19 634	Race, Bearing (t=1.8)		
	0338 19 635	Race, Bearing (t=2.0)		
	0338 19 636	Race, Bearing (t=2.2)		

**AUTOMATIC T / MISSION
(CLUTCH & PLANETARY GEAR)**

**AUTOMATIC T / MISSION
(CLUTCH & PLANETARY GEAR)**

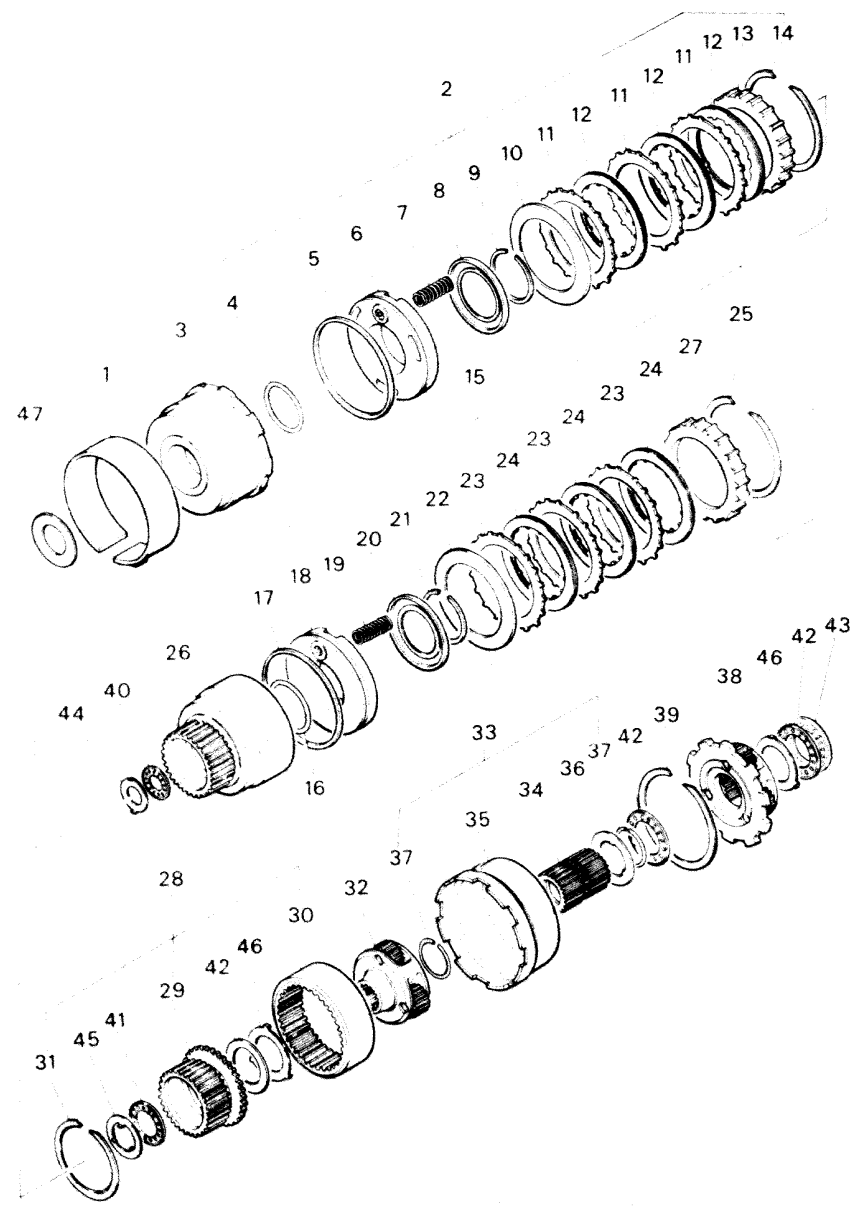

No.	Part Number	Description	Q'ty	Remarks
45	0338 19 638	Race, Bearing-Rear Clutch	1	
•	0436 19 656	Race, Bearing-Oil Distributor	1	77/5 ~ ○
46	0338 19 639	Race, Bearing	2	
47	0338 19 641	Washer, Front Clutch (t=1.90)		
	0338 19 642	Washer (t=2.10)		
	0338 19 643	Washer (t=2.30)		
	0338 19 644	Washer (t=2.50)	Selective use 1	
	0338 19 645	Washer (t=2.70)		
	0338 19 646	Washer (t=1.50)		
	0338 19 647	Washer (t=1.70)		
	0397 22 200	Clutch Repair Kit	1	
	0338 19 475	Seal, "O" Ring	2	
	0338 19 476	Seal, Lathe Cut	2	
	0338 19 486	Spring, Piston Return	20	
	0338 19 487	Retainer, Spring	2	
	0338 19 488	Ring, Snap	2	
	0338 19 498	Plate, Dished	2	
	0338 19 499	Plate, Driven	7	
	0338 19 500	Plate, Drive	7	
•	0338 19 500A	Plate, Drive	7	77/2 ~ ○
	0338 19 509	Ring, Snap	2	

AUTOMATIC T / MISSION (CLUTCH & PLANETARY GEAR)

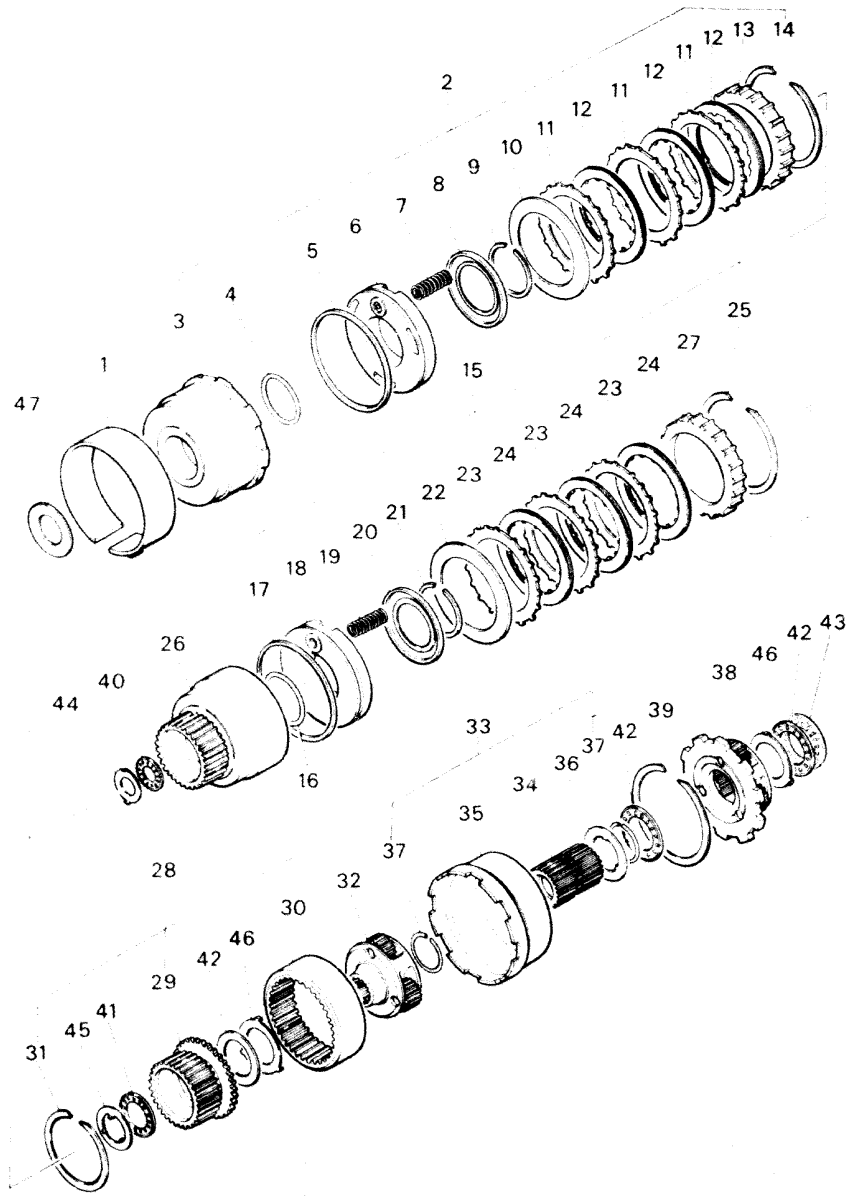

AUTOMATIC T / MISSION (CLUTCH & PLANETARY GEAR)

No.	Part Number	Description	Q'ty	Remarks
	0338 19 621	Bearing, Needle	1	
	0338 19 638	Race Bearing-Rear Clutch	1	
●	0436 19 656	Race, Bearing-Oil Distributor	1	77/5 ~ 0

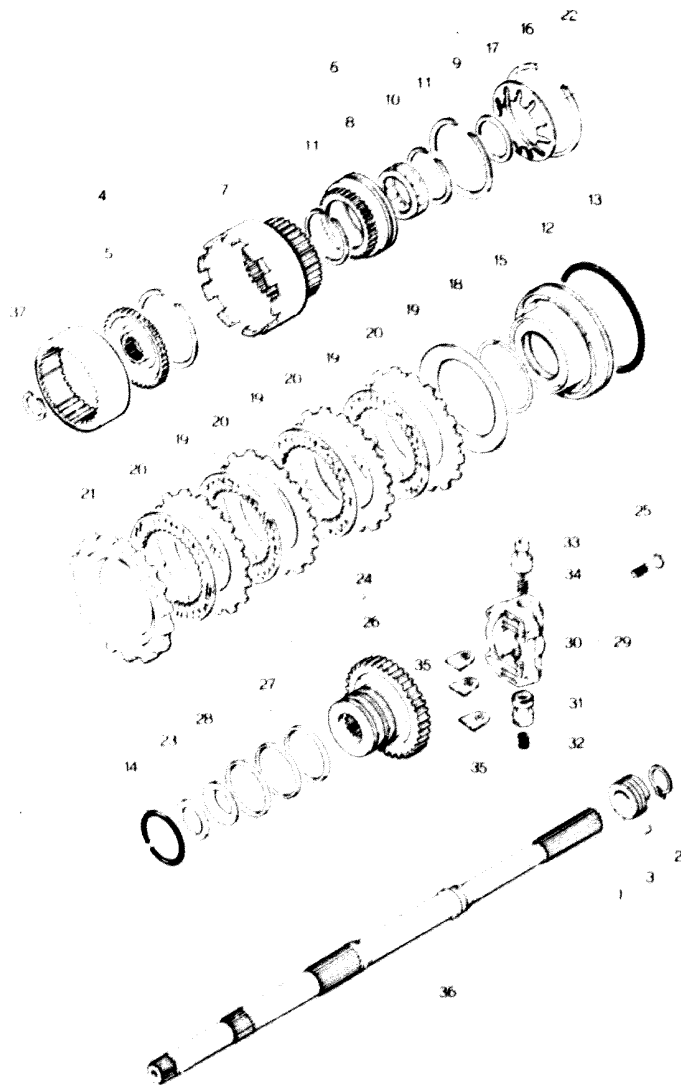
**AUTOMATIC T / MISSION
(LOW, REVERSE & GOVERNOR)**

**AUTOMATIC T / MISSION
(LOW, REVERSE & GOVERNOR)**

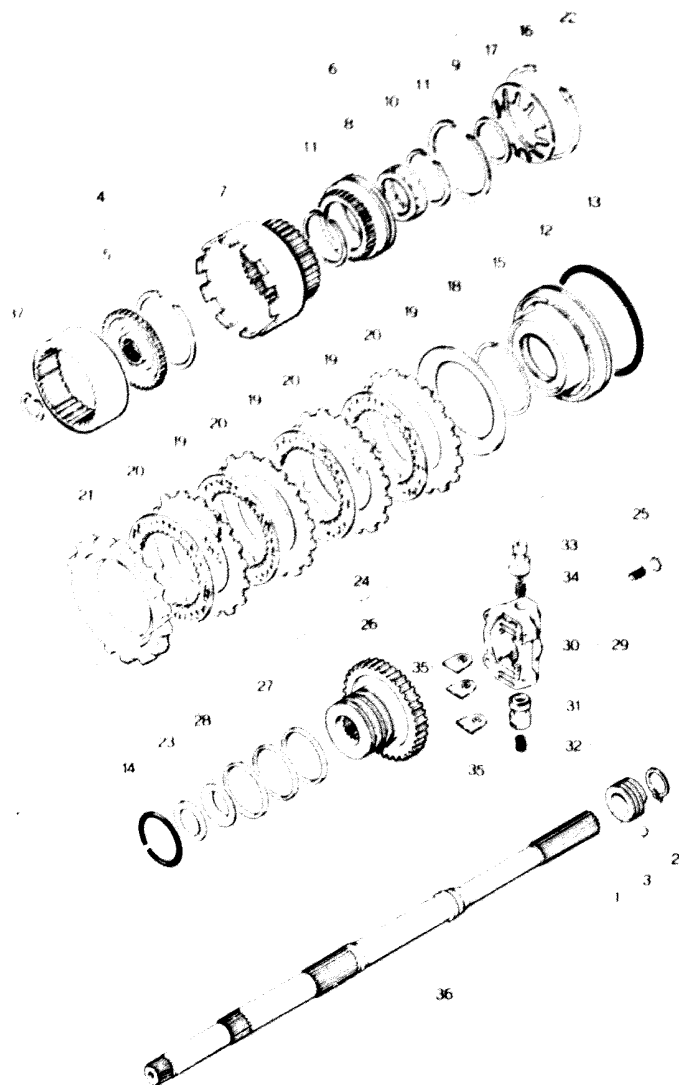
No.	Part Number	Description	Q'ty	Remarks
1	1281 17 341	Gear, Drive - Speedometer	1	
2	99573 2500	Ring, Snap - Drive Gear	1	
3	99611 1500	Ball, Steel	1	
4	0338 19 580	Flange	1	
5	0338 19 581	Flange, Drive	1	
6	0338 19 590	Drum, Connecting	1	
7	0338 19 591	Drum, Connecting	1	
8	0338 19 593	Race, Outer	1	
9	0338 19 594	Ring, Snap	1	
10	0338 19 595	Clutch, One Way	1	
11	0338 19 596	Ring, Snap	2	
12	0338 19 601	Piston, Low & Reverse	1	
13	0338 19 603	Seal, Piston	1	
14	0338 19 604	Seal, "O" Ring	1	
15	0338 19 605	Ring, Thrust Spring	1	
16	0338 19 606	Spring, Piston	1	
17	0338 19 607	Ring, Snap	1	

**AUTOMATIC T / MISSION
(LOW, REVERSE & GOVERNOR)**
**AUTOMATIC T / MISSION
(LOW, REVERSE & GOVERNOR)**

No.	Part Number	Description	Qty	Remarks
18	0338 19 608	Plate, Dished	1	
19	0338 19 609	Plate, Driven	4	
20	0338 19 610	Plate, Drive	4	
•	0338 19 610A	Plate, Drive	4	77/2 ~ 0
21	1758 19 613	Plate, Retaining (t 7.8)		
	1758 19 614	Plate (t 8.0)		
	1758 19 615	Plate (t 8.2)		
	1758 19 616	Plate (t 8.4)		Selective use 1
	1758 19 617	Plate (t 8.6)		
	1758 19 618	Plate (t 8.8)		
22	0338 19 619	Ring, Snap	1	
23	0338 19 622	Bearing, Needle	1	
24	0842 19 650	Distributor, Oil	1	
25	0338 19 397	Bolt	4	
26	0338 19 651	Distributor	1	
27	0338 19 655	Ring, Seal	3	
28	0338 19 656	Race, Bearing	1	
29	0842 19 660	Governor, Fig No 30-35 included	1	
30	0338 19 661	Body	1	
31	0338 19 663	Valve	1	

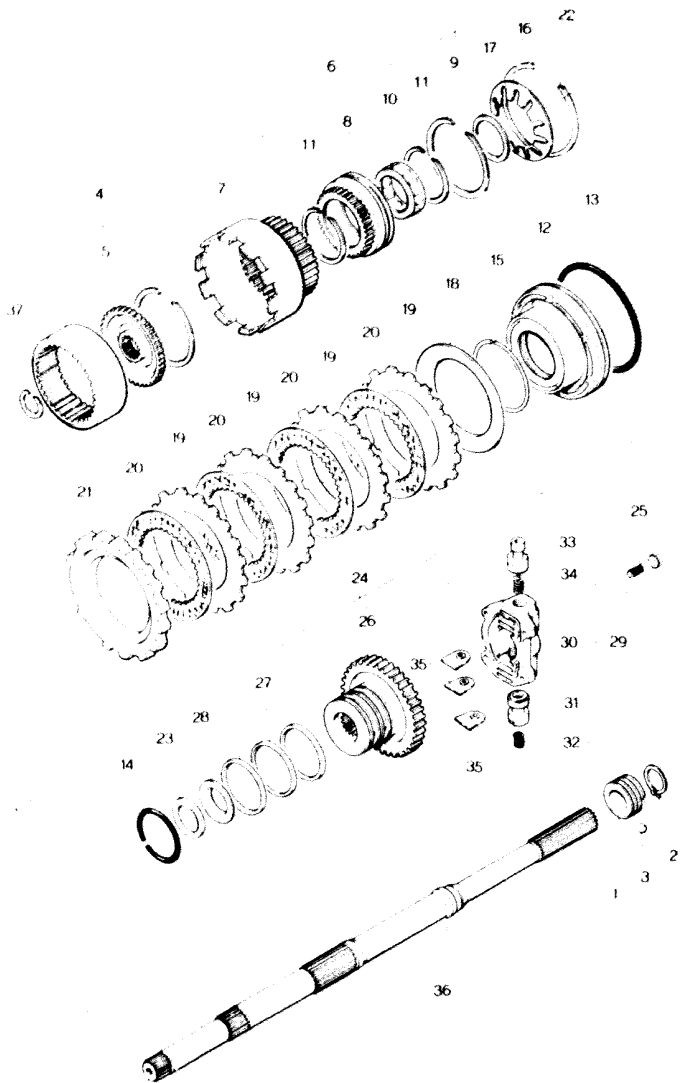
**AUTOMATIC T / MISSION
(LOW, REVERSE & GOVERNOR)**



**AUTOMATIC T / MISSION
(LOW, REVERSE & GOVERNOR)**

No.	Part Number	Description	Q'ty	Remarks
32	0338 19 664	Spring	1	
33	0842 19 665	Valve	1	
34	0338 19 666	Spring, Governor	1	
35	0338 19 667	Plate, Retainer	3	
36	0338 19 670 A	Shaft	1	
37	0338 19 676	Ring	1	

**AUTOMATIC T/MISSION
(MANUAL LINKAGE)**

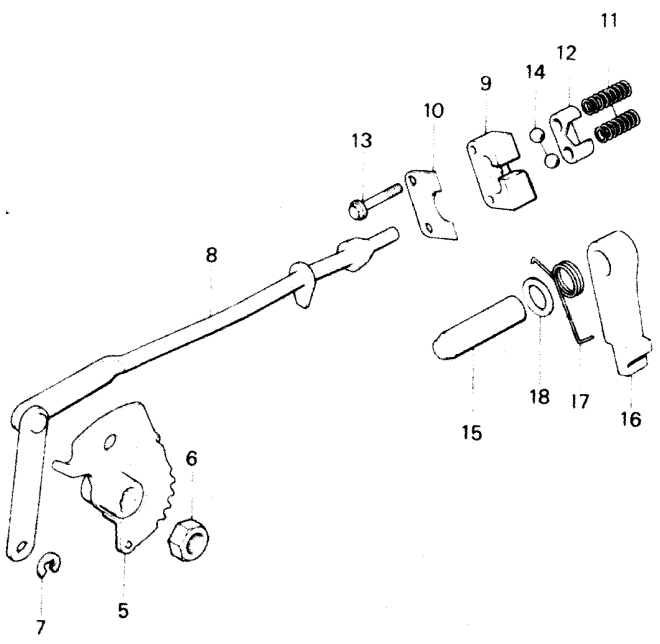
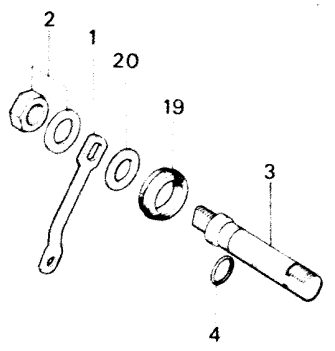

**AUTOMATIC T/MISSION
(MANUAL LINKAGE)**

No.	Part Number	Description	Q'ty	Remarks
1	1015 19 031	Lever, Select	1	
2	99922 1400	Nut, Select Lever	1	
	99971 1400	Washer, Spring	1	
3	1181 19 431B	Shaft, Manual	1	
4	99541 0120!	Ring, "O"	1	
5	1758 19 440A	Plate, Manual	1	
6	1758 19 443	Nut, Shaft	1	
7	0338 19 449	Ring, Snap	1	
8	1758 19 450	Rod, Parking	1	
9	0338 19 701A	Support, Actuator	1	
10	0338 19 702A	Plate, Retaining	1	
11	0338 19 703	Spring, Ball Park	2	
12	0338 19 704	Retainer	1	
13	0338 19 706	Bolt	2	
14	99611 2750	Ball, Steel	2	
15	0338 19 731	Shaft, Parking Pawl	1	
16	0338 19 732	Pawl, Parking	1	
17	0338 19 733C	Spring, Pawl Return	1	

19

**AUTOMATIC T/MISSION
(MANUAL LINKAGE)**

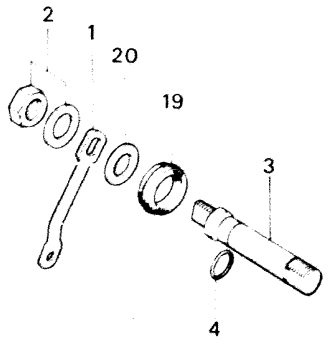

19

**AUTOMATIC T/MISSION
(MANUAL LINKAGE)**

No.	Part Number	Description	Q'ty	Remarks
18	0338 19 734A	Spacer, Dowel	1	
19	1758 19 036A	Seal, Dust	1	
20	1758 19 055	Washer	1	

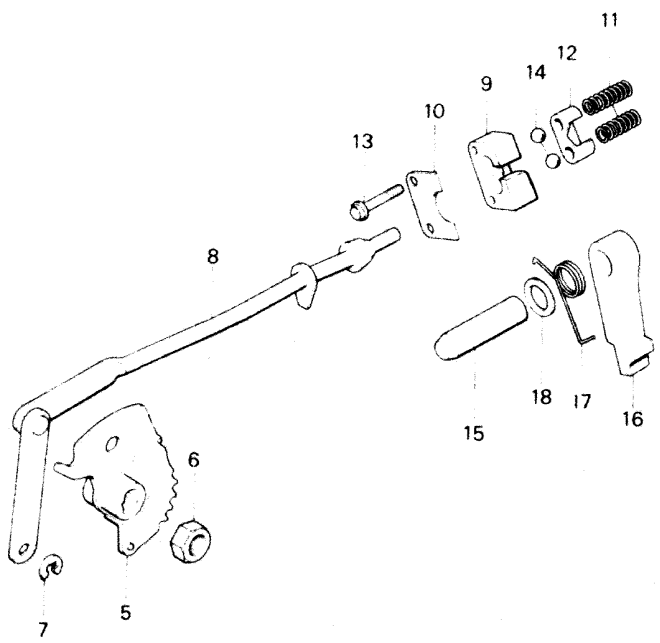

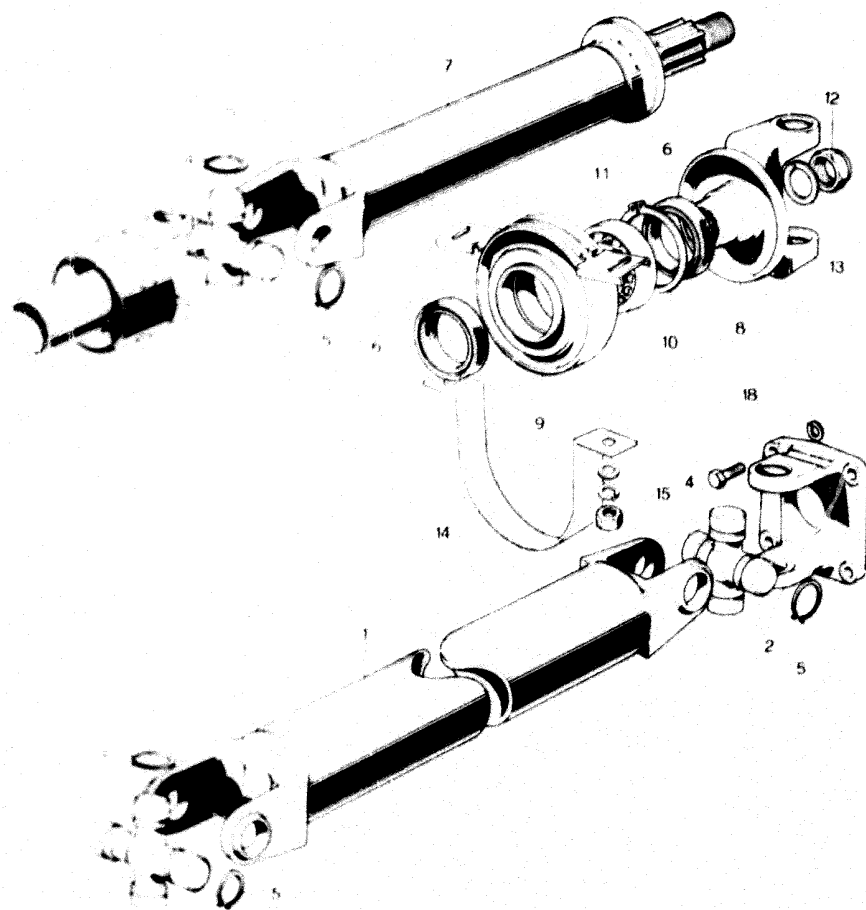

No.	Part Number	Description	Q'ty	Remarks
	3790 25 100	Shaft Propeller	1	
1	2677 25 010	Shaft Propeller	1	
2	2677 25 015	Yoke, Universal Joint	1	
3	0578 25 130	Yoke, Sliding	1	
4	0706 89 251	Joint Set, Universal Fig No. 5 included	3	
5	2677 25 071	Ring, Snap (t = 1.45)		
	2677 25 072	Ring, Snap (t = 1.48)		
	2677 25 073	Ring, Snap (t = 1.51)		
	2677 25 074	Ring, Snap (t = 1.54)	12	Selective use
	2677 25 075	Ring, Snap (t = 1.57)		
	2677 25 076	Ring, Snap (t = 1.60)		
	2677 25 077	Ring, Snap (t = 1.63)		
6	0290 25 151	Oil Seal	2	
7	3790 25 210	Shaft, Propeller	1	
8	2677 25 220	Yoke	1	

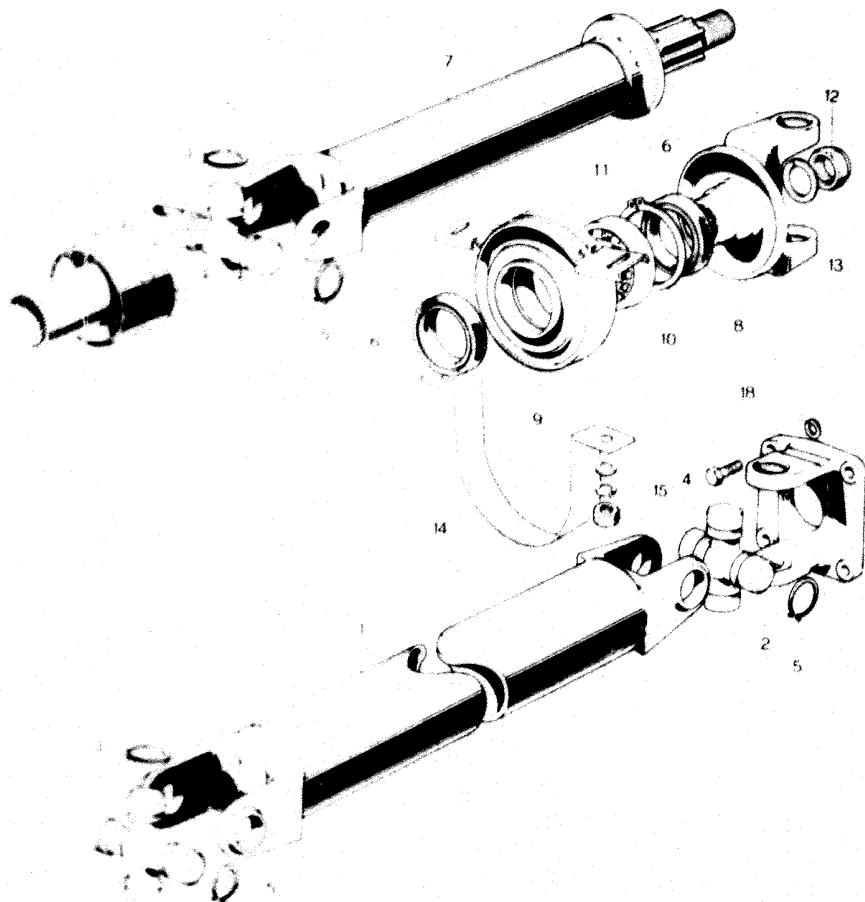

No.	Part Number	Description	Qty	Remarks
9	1856 25 300A	Support. Center Bearing	1	
10	99574 5200	Ring. Snap	1	
11	99606 62050	Bearing. Ball	1	
12	99922 1800	Nut. Yoke	1	
13	99971 1800	Washer. Spring	1	
14	1856 25 314	Protector	1	
15	99940 1001	Nut. Protector	2	
16	2788 18 368	Spacer. Protector	2	
17	8884 39 387	Washer. Protector	2	
18	99750 11020	Bolt Propeller Shaft	4	
	99971 1000	Washer. Spring	4	

No.	Part Number	Description	Q'ty	Remarks
1	3790 26 010	Casing, Rear Axle	1	
2	99789 0820F	Stud	10	
3	0259 26 051	Plug, Drain, Magnet	1	
4	0419 26 060	Breather, Axle Casing	1	
5	0187 26 092	Screw, Breather	1	
6	0088 26 063	Cap, Breather	1	Recipro
7	99221 1622	Pin, Split, Breather	1	
8	99502 4000	Plug, Oil Level	1	
9	99901 0800	Nut, Casing	10	
	99971 0800	Washer, Spring	10	
10	1854 26 111A	Shaft, R, Rear Axle	1	
	1854 26 115A	Shaft, (L), Rear Axle	1	
11	99254 4014	Rivet, Rear Axle Shaft	8	
12	1854 26 113A	Bolt, Hub	12	

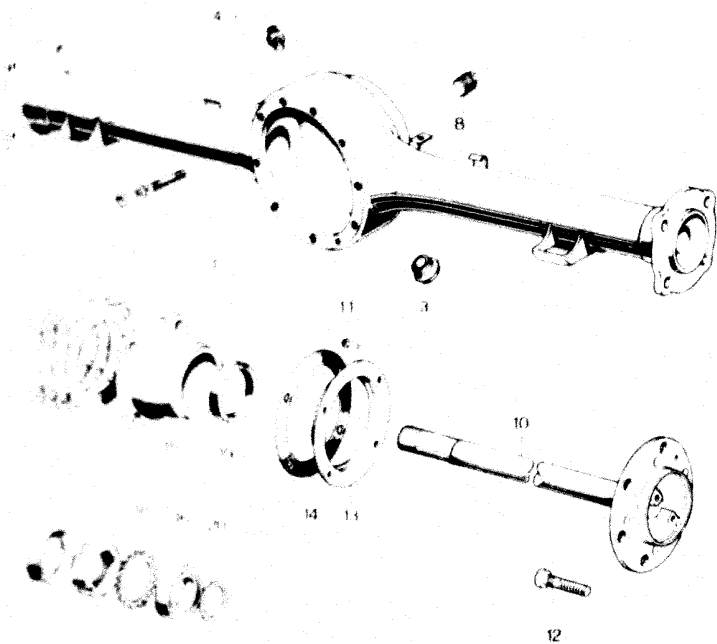

No.	Part Number	Description	Qty	Remarks
13	0604 26 125B	Baffle, Oil	2	
14	0604 26 129	Gasket, Oil Baffle	2	
15	0603 26 131 A	Housing, Bearing	2	
16	99603 02080	Bearing, Axle Shaft	2	
17	0603 26 152	Nut (R), Lock	1	
	0603 26 156	Nut (L), Lock	1	
18	0602 26 153	Washer, Lock	2	
19	0603 26 154	Oil Seal, Inner	2	
20	0603 26 155	Spacer, Bearing	2	
21	0603 26 157	Oil Seal, Outer	2	
22	0603 26 165	Shim, Adjust		
	0603 26 166	Shim, Adjust		
	0603 26 167	Shim, Adjust		Selective use
	0603 26 168	Shim, Adjust		

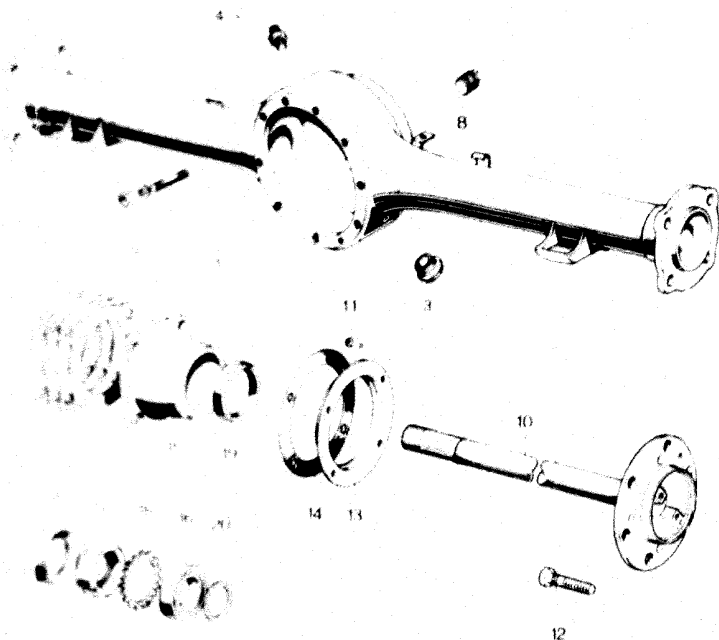

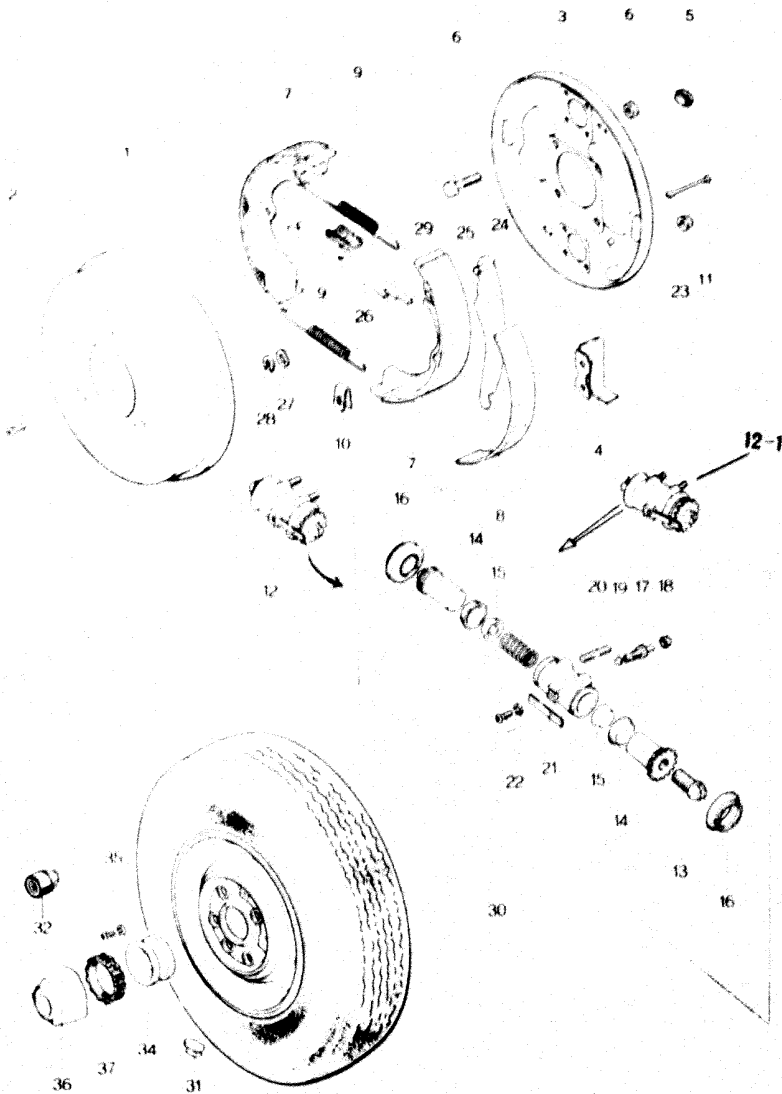

No.	Part Number	Description	Q'ty	Remarks
1	0603 26 251 A	Drum, Brake	2	
2	99831 0616	Screw, Brake Drum	4	
3	0603 26 281 B	Plate (R), Brake Drum	1	
	0603 26 291 B	Plate (L), Brake Drum	1	
4	0589 26 287 A	Guard (R), Brake Pipe	1	
	0589 26 297 A	Guard (L), Brake Pipe	1	
5	0603 26 288	Plug, Drum Cover	4	
6	0603 26 301	Bolt, Brake Drum Cover	8	
	99942 1000	Nut, Self Lock	8	
7	1823 26 310 B	Shoe, Brake	4	
8	1823 26 312 B	Lining, Brake	4	
9	0603 26 341	Spring, Return	4	
10	0223 26 345 A	Spring, Clip	4	
11	0223 26 391	Pin, Guide - Brake Shoe	4	
12	0647 26 610 A	Cylinder (R)	1	

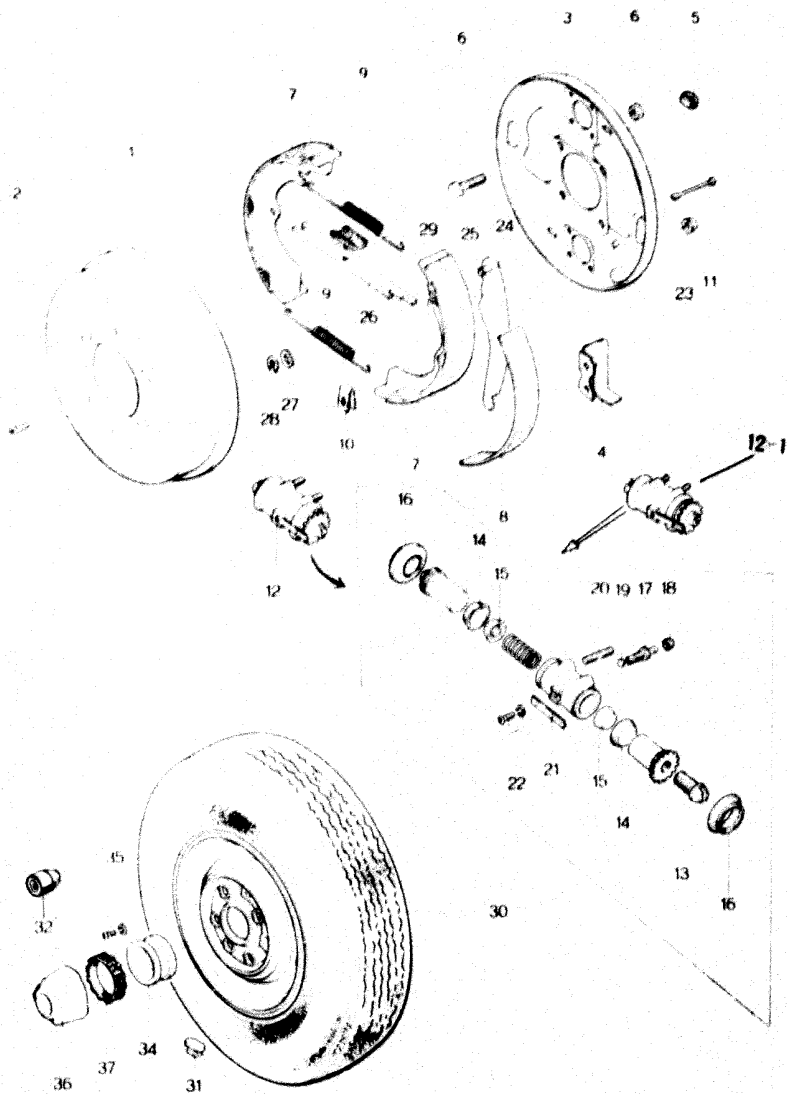

No.	Part Number	Description	Q'ty	Remarks
	0647 26 710A	Cylinder (L)	1	
12-1	3874 26 510	Cylinder	2	
13	0604 26 465	Screw, Adjusting	4	
14	0187 33 671 A	Cup, Piston (Recipro)	8	
	0208 26 671	Cup, Piston (Rotary)	8	
15	1312 33 673	Block, Filling	8	
16	0603 33 681 A	Cover, Dust	8	
17	0259 33 691	Screw, Bleeder	4	
18	0259 33 693	Cap, Bleeder Screw	4	
19	99611 1500	Ball, Steel	4	
20	99852 0614	Stud	16	
21	0304 33 352 A	Spring	4	
22	99833 0406	Screw, Spring	4	
	99971 0400	Washer, Spring	4	
23	99940 0600	Nut, Wheel Cylinder	16	
24	0603 26 800 A	Lever (R), Operating	1	
	0603 26 810 A	Lever (L), Operating	1	
25	0604 26 832	Pin	2	

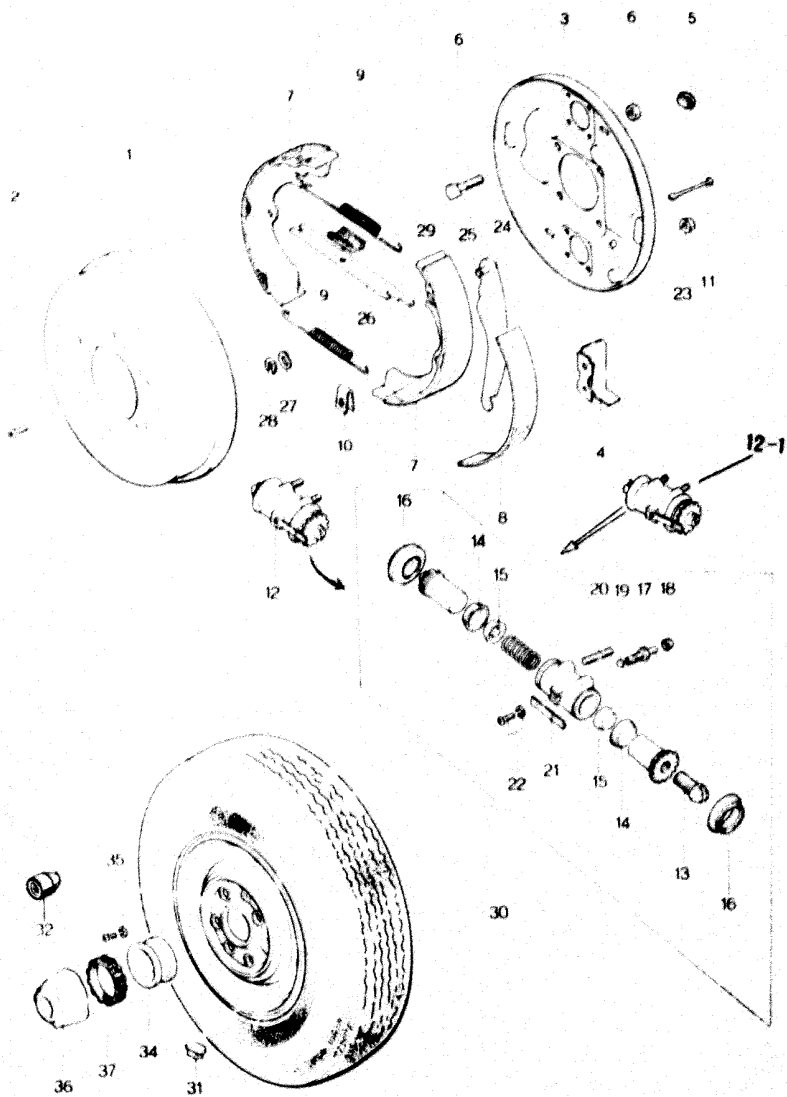

No.	Part Number	Description	Q'ty	Remarks
34	1854 26 570 A	Adapter, Center Emblem	2	
35	99833 0812	Screw, Adapter	4	
	99971 0800	Washer, Spring	4	
36	1854 33 191	Emblem, Center Cap	2	
37	1854 33 192	Rubber, Set-Center Cap	2	

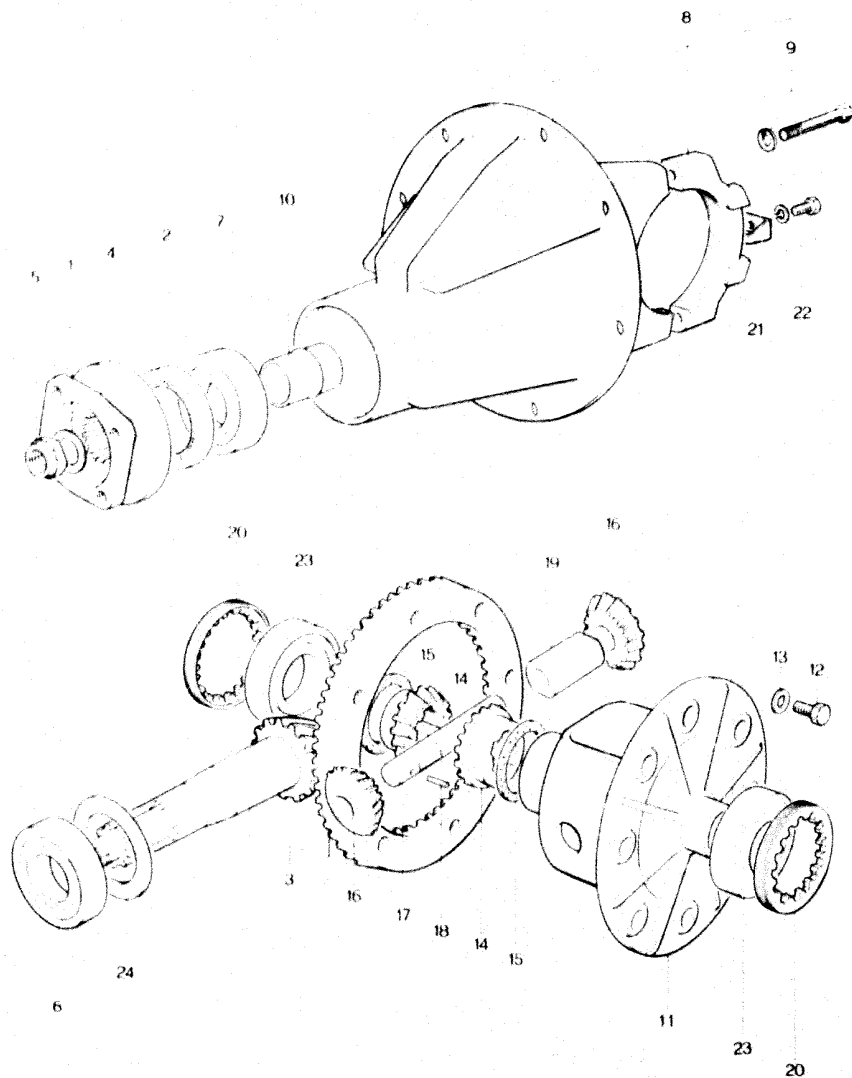

No.	Part Number	Description	Q'ty	Remarks
	3790 27 100	Driving & Differential	1	
1	0012 27 012	Washer	1	
2	0604 27 018	Oil Seal	1	
3	3790 27 110	Gear Set, Final (Ratio : 3.90)	1	
4	0579 27 120 A	Flange, Companion	1	
5	0578 27 130 A	Nut, Lock	1	
6	0603 27 141	Bearing, Rear-Drive Pinion	1	
7	0604 27 142	Bearing, Front-Drive Pinion	1	
8	0578 27 150 D	Carrier, Differential	1	
9	99811 1255 A	Bolt, Carrier	4	
	99971 1200	Washer, Spring	4	
10	0305 27 171	Piece, Distance	1	

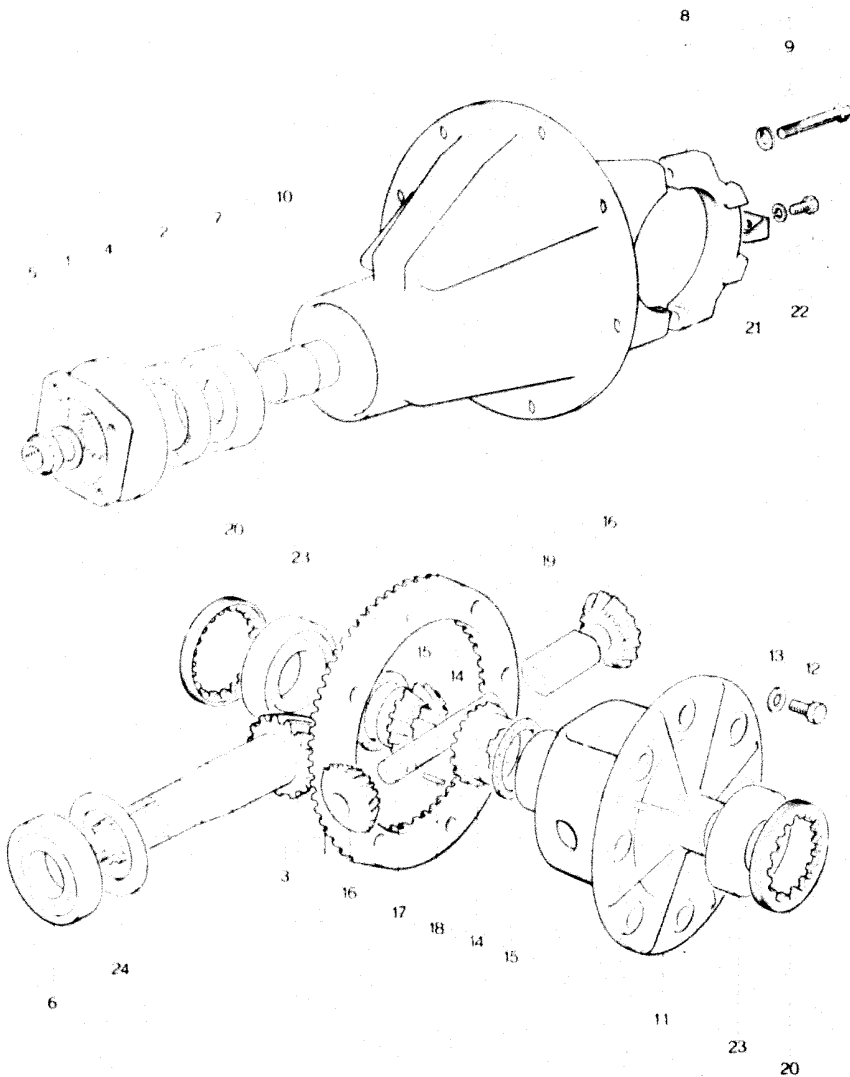

No.	Part Number	Description	Qty	Remarks
11	3874 27 231	Case, Gear - Differential	1	
12	99753 21022	Bolt, Gear Case	Selective use	10
	99753 61022	Bolt, Gear Case		
13	99958 1018	Washer, Lock	10	
14	0603 27 251	Gear, Side	2	
15	0578 27 252	Washer, Thrust-Side Gear	Selective use	2
	0578 27 253	Washer, Thrust-Side Gear		
	0578 27 254	Washer, Thrust-Side Gear		
16	0603 27 255	Pinion, Differential	2	
17	0578 27 261	Shaft, Differential Pinion	1	
18	0114 27 262	Pin, Pinion Shaft	1	
19	0603 27 263	Block, Thrust Pinion Shaft	1	

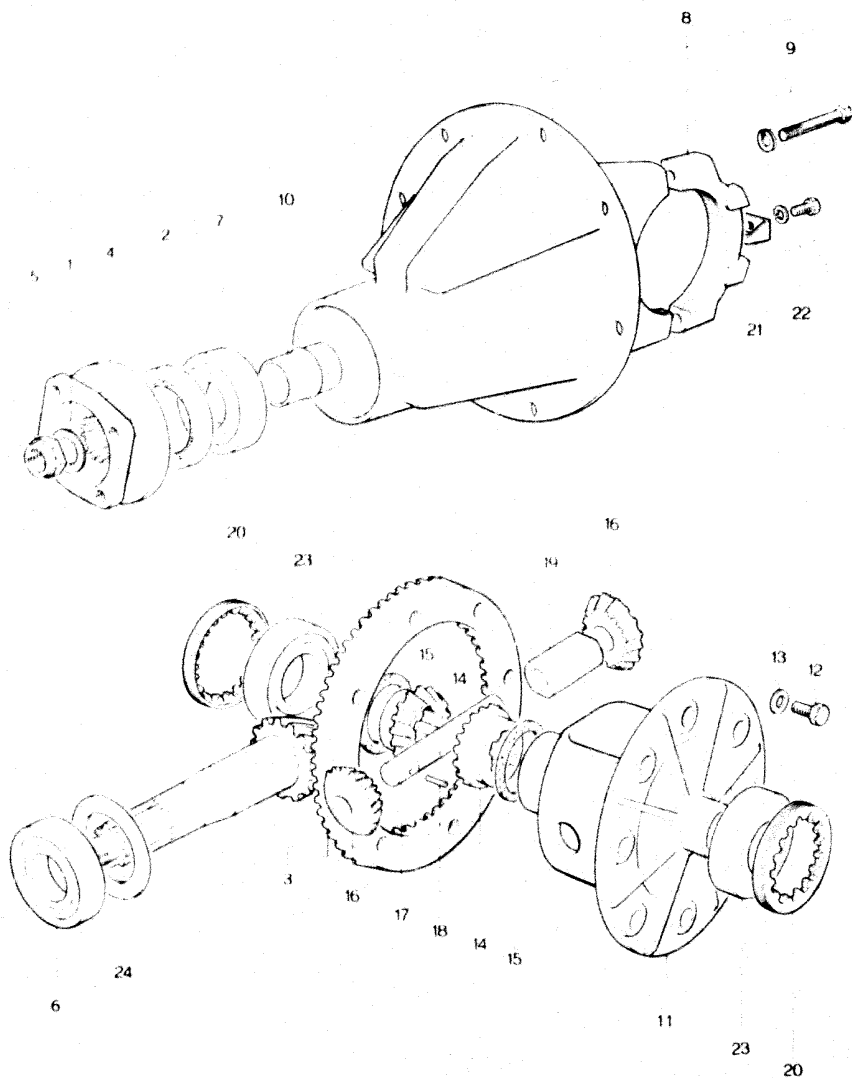

No.	Part Number	Description	Q'ty	Remarks
20	0110 27 301	Screw, Adjust	2	
21	0578 27 302	Plate, Lock Carrier	2	
22	99796 8112	Bolt, Lock Plate	2	
23	0118 27 305	Bearing, Differential Gear	2	
24	0223 27 401 A	Spacer (t=3.08)		
	0223 27 402 A	Spacer (t=3.11)		
	0223 27 403 A	Spacer (t=3.14)		
	0223 27 404 A	Spacer (t=3.17)		
	0223 27 405 A	Spacer (t=3.20)		
	0223 27 406 A	Spacer (t=3.23)		
	0223 27 407 A	Spacer (t=3.26)		
	0223 27 408 A	Spacer (t=3.29)		Selective use 1
	0223 27 409 A	Spacer (t=3.32)		
	0223 27 411 A	Spacer (t=3.35)		
	0223 27 412 A	Spacer (t=3.38)		
	0223 27 413 A	Spacer (t=3.41)		
	0223 27 414 A	Spacer (t=3.44)		
	0223 27 415 A	Spacer (t=3.47)		

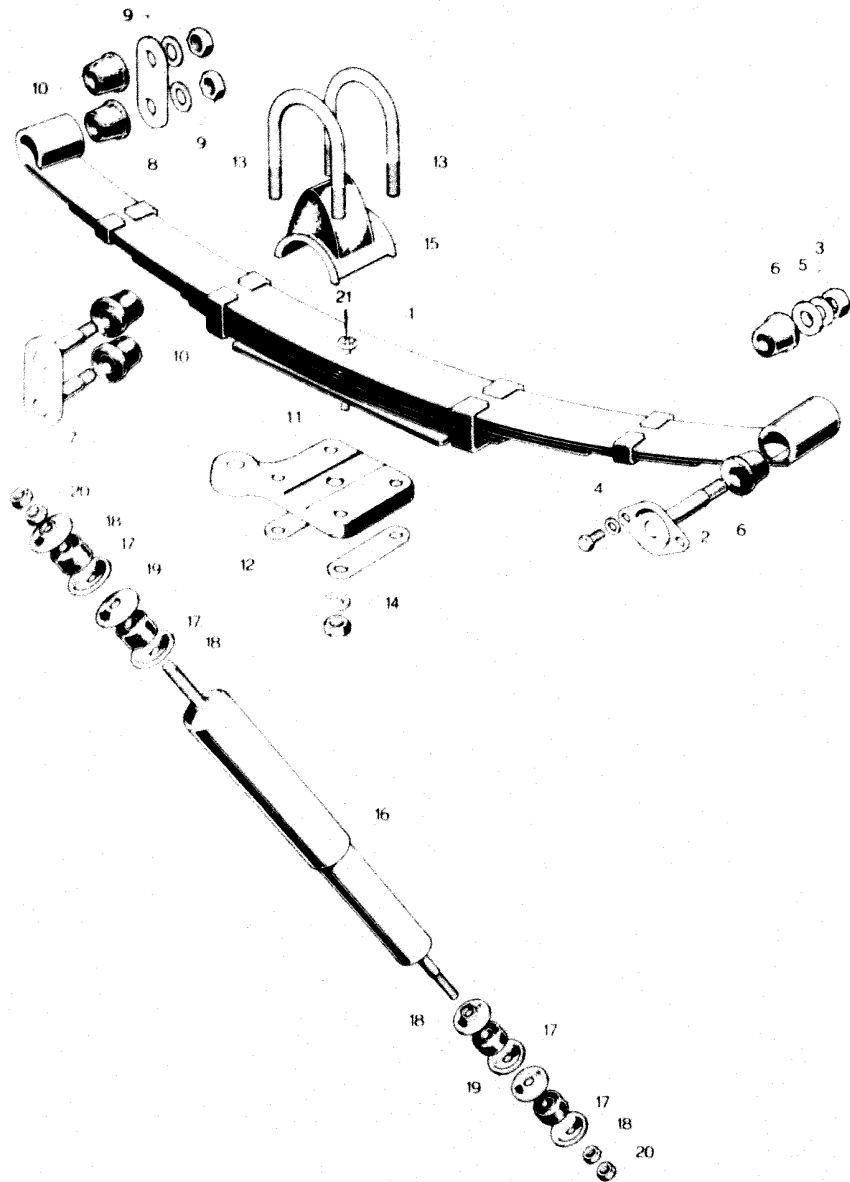

No.	Part Number	Description	Q'ty	Remarks
1	3874 28 010A	Spring, Rear	2	
	3874 28 011	Leaf No. 1	2	
	3874 28 012	Leaf No. 2	2	
	3874 28 013	Leaf No. 3	2	
	3874 28 014	Leaf No. 4	2	
	3874 28 015	Leaf No. 5	2	
	3874 28 016	Leaf No. 6	2	
2	0603 28 110	Pin, Spring	2	
3	99921 1400	Nut	2	
	99971 1400	Washer, Spring	2	
4	99811 1020	Bolt	4	
	99971 1000	Washer, Spring	4	
5	0603 28 114	Spacer	2	
6	3874 28 330	Bush, Rubber	4	
7	0603 28 140	Plate, Shackle	2	
8	0603 28 142	Plate, Shackle	2	
9	99921 1400	Nut	4	
	99971 1400	Washer, Spring	4	
10	3874 28 330	Bush, Rubber	8	

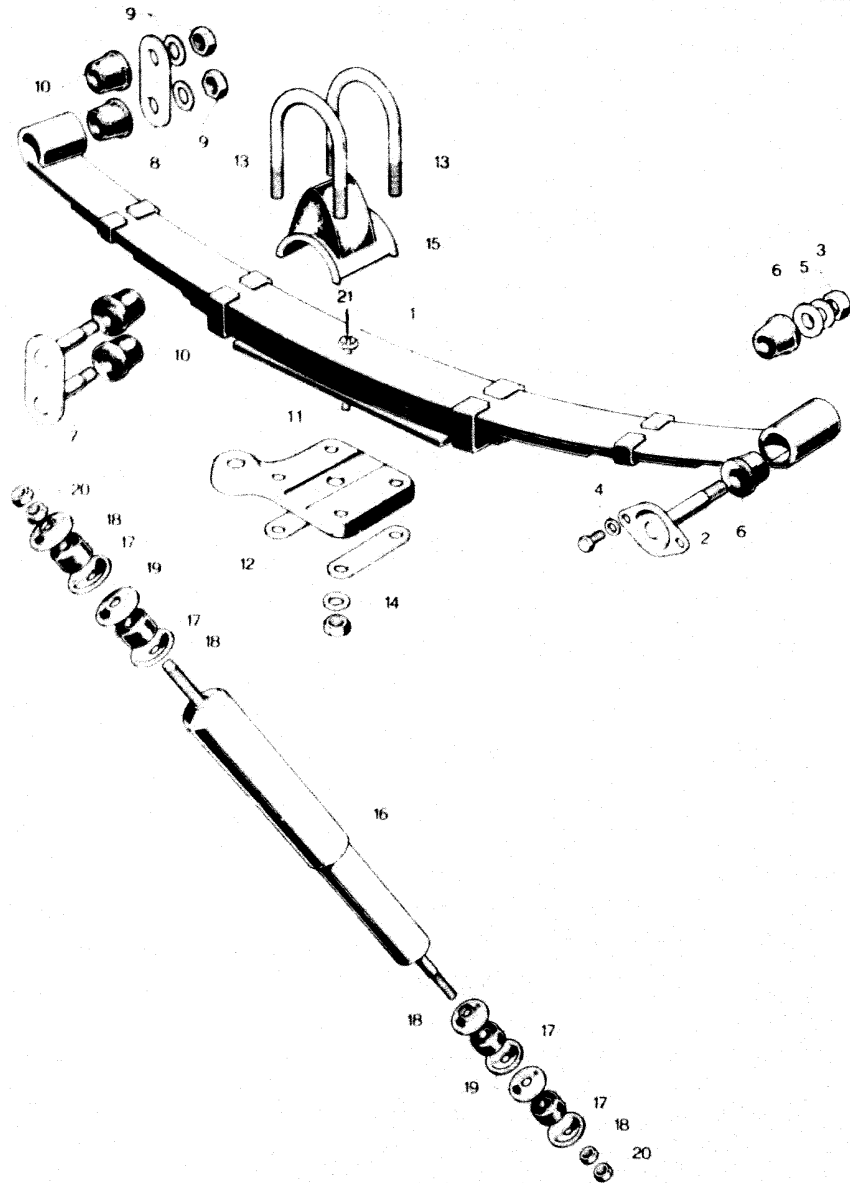

No.	Part Number	Description	Q'ty	Remarks
11	0603 28 151	Clamp (R), Spring	1	
	0603 28 171	Clamp (L), Spring	1	
12	0603 28 152	Patch, Spring Clamp	4	
13	0603 28 161	Bolt, Lock	4	
14	99928 1200	Nut, Lock Bolt	8	
	99971 1200	washer, Spring	8	
15	0603 28 320	Rubber, Stopper	2	
16	3874 28 700	Damper, Rear	2	
17	0603 34 153	Bush, Rubber	8	
18	0187 34 776	Retainer	8	
19	0187 34 777	Washer, Centering	8	
20	99922 1000	Nut, Rear Damper	4	
	99921 1000	Nut	4	
21	3874 28 981	Bolt, Center	2	

STEERING SYSTEM (WHEEL & GEAR)

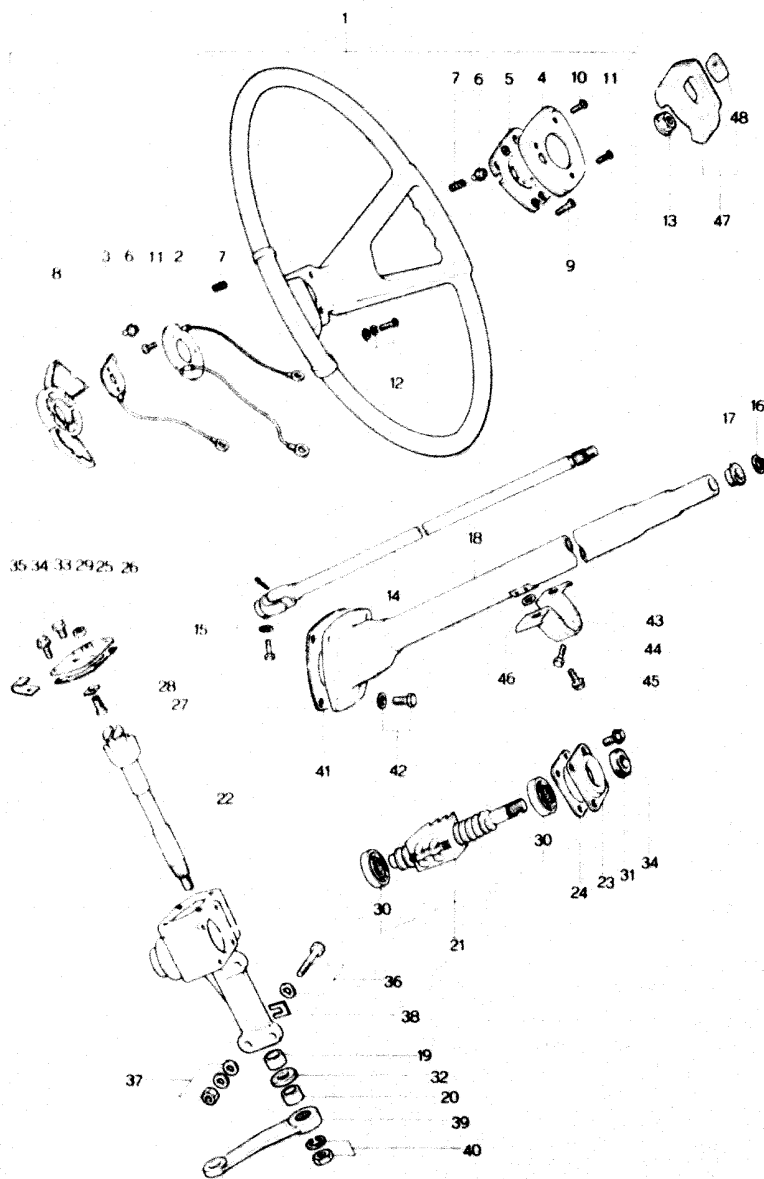

STEERING SYSTEM (WHEEL & GEAR)

No.	Part Number	Description	Q'ty	Remarks
1	1854 32 980	Boss, Steering Wheel	1	
2	1854 32 018	Terminal	1	
3	1175 32 030	Plate, Earth "C"	1	
4	1175 32 041	Plate, Set	1	
5	1175 32 042	Cap	1	
6	1175 32 043	Insulator	3	
7	1175 32 044	Spring	3	
8	1854 32 049	Cover, Wheel Core	1	
9	99831 0310	Screw	2	
10	99833 0308	Screw	1	
11	99863 0308	Screw	6	
12	99863 0312	Screw	3	
	99953 0300	Washer, Plain	3	
	99971 0300	Washer, Spring	3	
13	99948 1200	Nut, Steering Wheel	1	
14	1854 32 050A	Shaft, Column	1	
15	1854 32 888	Bolt, Column Shaft	1	
	99971 0800	Washer, Spring	1	
	99221 2012	Pin, Split	1	

STEERING SYSTEM
(WHEEL & GEAR)

STEERING SYSTEM
(WHEEL & GEAR)

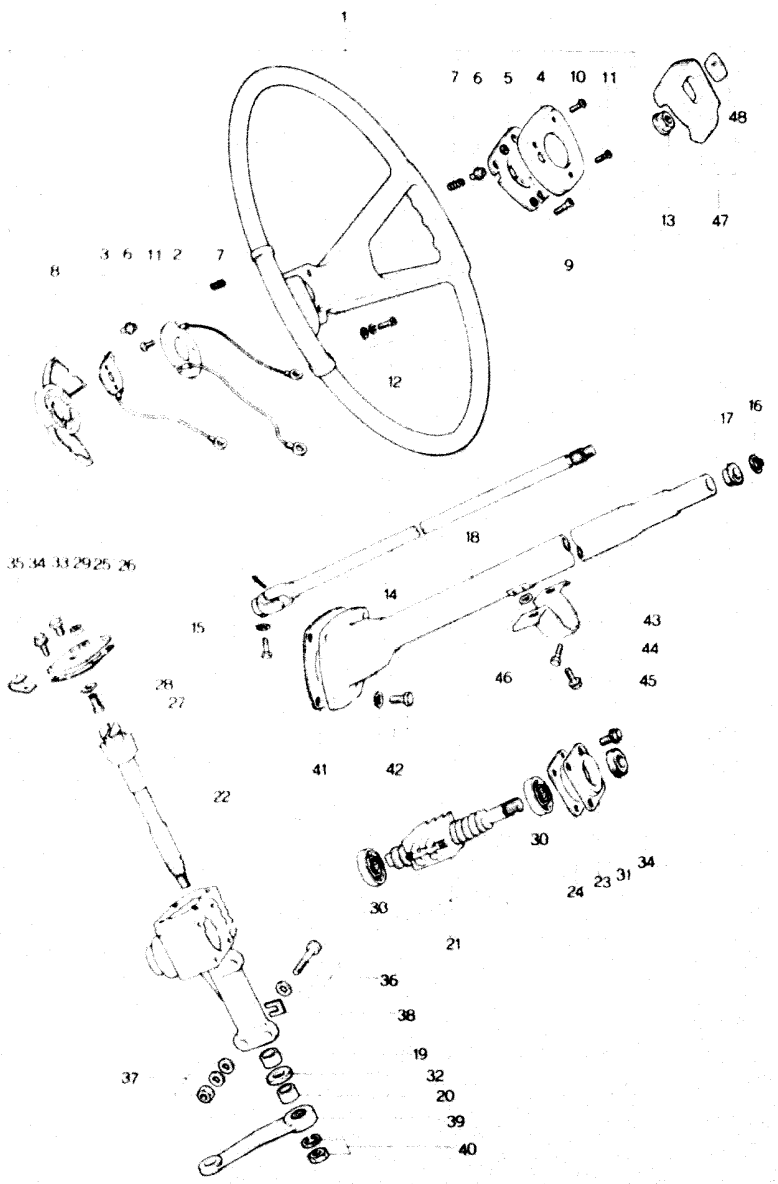

No.	Part Number	Description	Q'ty	Remarks
16	0208 32 059	Ring, Stop	1	
17	0259 32 071	Bush, Shaft Support	1	
18	1854 32 080	Jacket, Column Shaft	1	
	1854 32 110	Gear, Steering	1	
19	0603 32 122	Bush	1	
20	0603 32 122	Bush	1	
21	1854 32 130	Ball Nut, Worm (Fig No 30 Included)	1	
22	1854 32 141	Shaft, Sector	1	
23	1854 32 151	Cover, End	1	
24	1854 32 154	Shim, End Cover (t 0.05)		Selective use 1
	1854 32 155	Shim (t 0.06)		
	1854 32 156	Shim (t 0.07)		
	1854 32 157	Shim (t 0.08)		
	1854 32 158	Shim (t 0.10)		
	1854 32 159	Shim (t 0.20)		
25	1854 32 161	Cover, Side-Steering Gear	1	
26	1854 32 163	Gasket, Side Cover	1	
27	0180 32 165A	Screw, Adjust-Sector	1	
28	0180 32 171A	Shim, Adjust (t 1.95)		

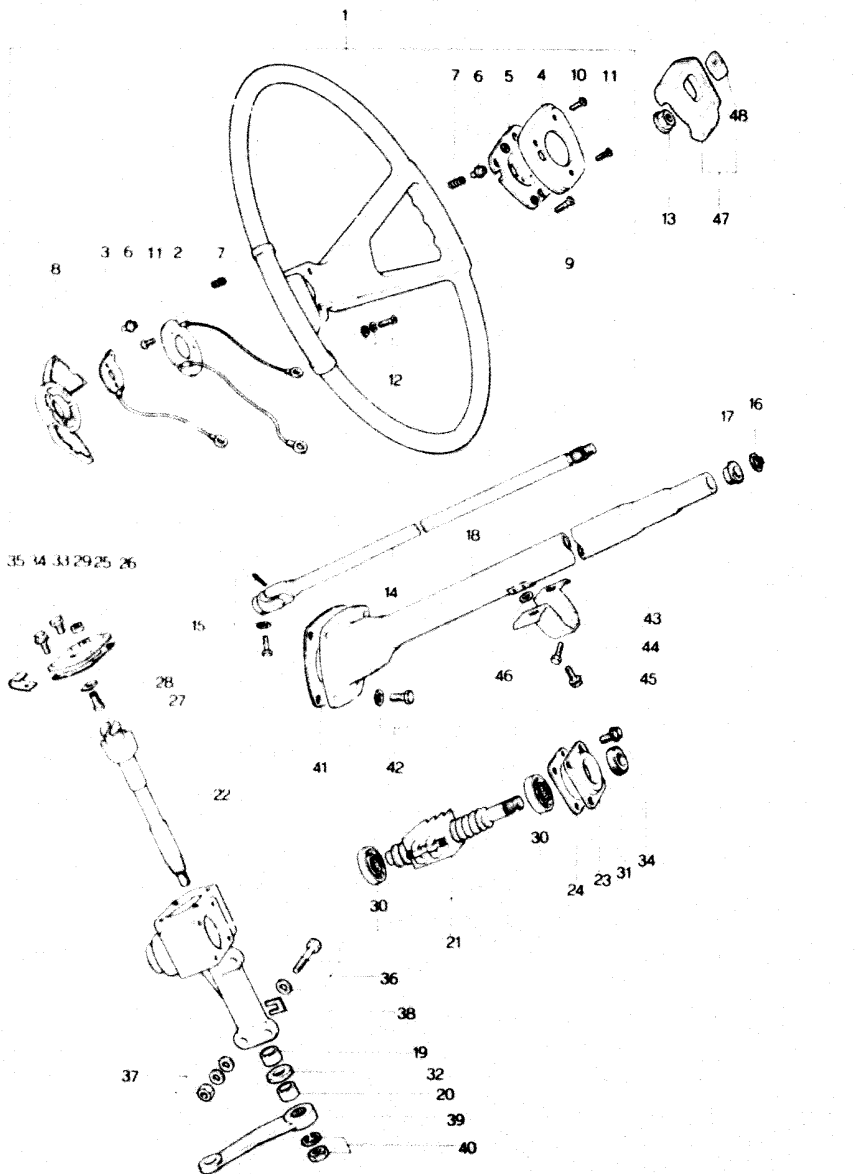

No.	Part Number	Description	Q'ty	Remarks
	0190 32 172A	Shim (t=2.00)		Selective use 1
	0180 32 173A	Shim (t=2.05)		
	0180 32 174A	Shim (t=2.10)		
29	99922 1000	Nut, Lock - Adjust Screw	1	
30	0183 32 182	Bearing, Worm Ball Nut	2	
31	0180 32 184	Oil Seal, Worm	1	
32	99583 28388	Oil Seal, Sector Shaft	1	
33	0820 32 190	Plug, Oil	1	
34	99781 0822	Bolt, End + Side Cover	8	
	99971 0800	Washer, Spring	8	
35	95276 1002	Clip, Side Cover	1	
36	0603 32 186	Bolt, Gear Housing	3	
37	99921 1000	Nut, Gear Housing	3	
	99971 1000	Washer, Spring	3	
	99951 1022	Washer, Plain	2	
38	0208 32 188	Shim, Adjust - Selective use	3	
39	3874 32 226	Arm, Pitman	1	
40	99921 2000	Nut, Pitman Arm	1	
	99971 2000	Washer, Spring	1	

STEERING SYSTEM (WHEEL & GEAR)

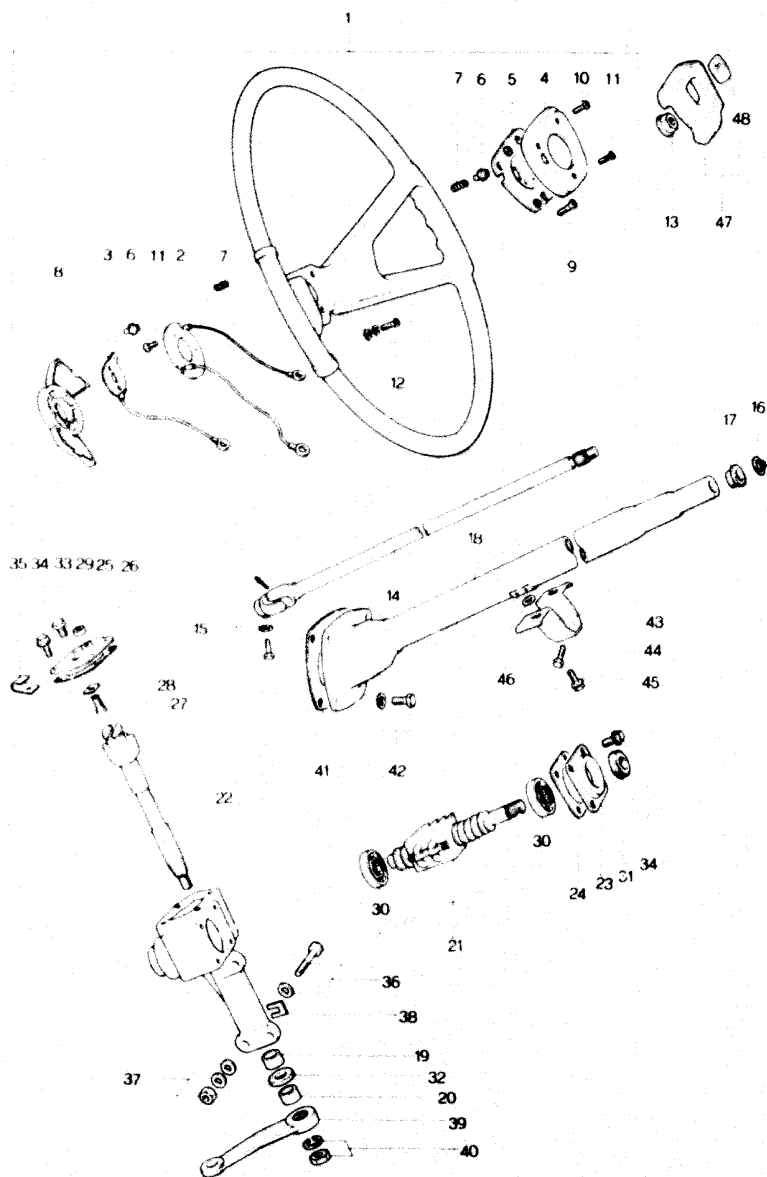

STEERING SYSTEM (WHEEL & GEAR)

No.	Part Number	Description	Q'ty	Remarks
41	1757 32 411A	Cover, Dust	1	
•	1757 32 411B	Cover, Dust	1	77/8 ~ Δ
42	99786 0620	Screw, Tapping-Dust Cover	4	
	99952 0618	Washer, Plain	4	
43	1854 32 421	Bracket, Column Fixing	1	
44	99801 0810B	Bolt, Bracket - Jacket	4	
	99971 0800	Washer, Spring	4	
45	99794 0825B	Bolt, Bracket - Body	2	
	99951 0822	Washer, Plain	2	
	99971 0800	Washer, Spring	2	
46	99951 1030B	Washer, Plain - Bracket	2	
47	1793 32 800	Cap, Center - Steering Wheel	1	
48	1727 32 811	Emblem	1	

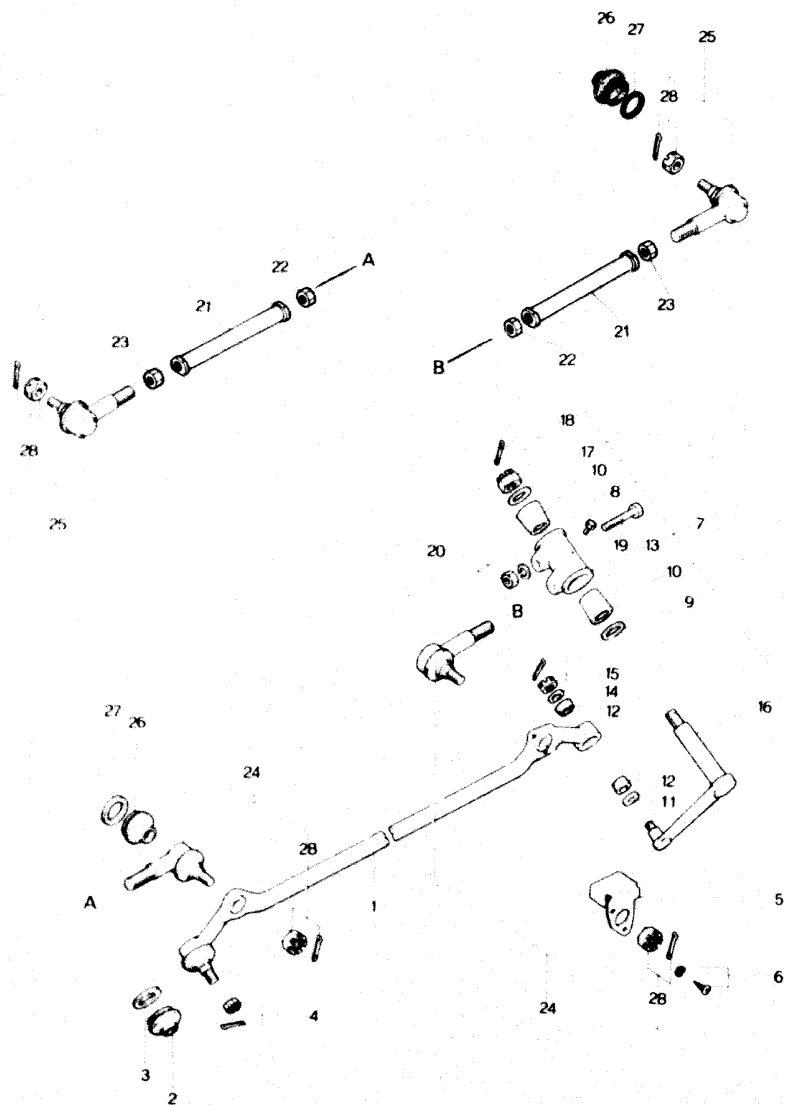

No.	Part Number	Description	Q'ty	Remarks
1	3790 32 250	Link Center	1	
2	1823 32 279	Seal, Dust	1	
3	1823 32 289	Ring, Dust Seal	1	
4	99924 1200	Nut, Center Link	1	
	99221 3020	Pin, Split	1	
5	1854 32 267	Insulator	1	
6	99833 0612	Screw, Insulator	2	
	99971 0600	Washer, Spring	2	
7	2541 32 320	Idler	1	Ord By 2844 49 120
8	0208 32 278	Plug	2	
9	0208 32 324 B	Seal, Dust	1	
10	0208 32 326	Bush, Tapered	2	
11	0208 32 328 A	Seal, Dust	1	
12	0208 32 329	Bush, Tapered	2	
13	0208 32 331 A	Bracket, Idler	1	
14	0208 32 340 A	Seal, Dust	1	
15	99924 1200	Nut	1	
	99221 3020	Pin, Split	1	

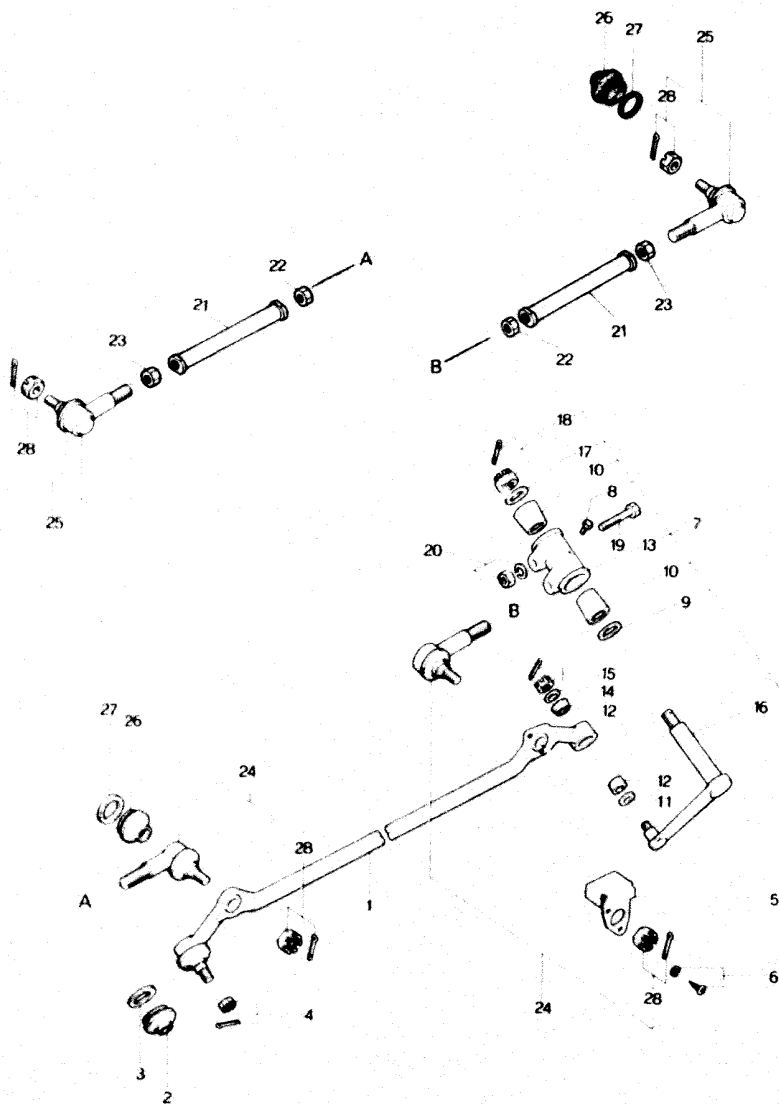

No.	Part Number	Description	Qty	Remarks
16	2541 32 351 A	Arm, Idler	1	
17	0208 32 360 A	Seal, Dust	1	
18	99924 1400	Nut	1	
	99221 3025	Pin, Split	1	
19	0603 32 355	Bolt, Idler	2	
20	99921 1000	Nut, Idler	2	
	99971 1000	Washer, Spring	2	
21	0603 32 365 B	Rod, Tie	2	
22	99922 1600	Nut	2	
23	99944 1600	Nut	2	
24	3874 99 322	Socket Set	2	
25	3874 99 324	Socket Set	2	
26	1823 32 279	Seal, Dust	4	
27	1823 32 289	Ring, Dust Seal	4	
28	99924 1200	Nut	4	
	99221 3020	Pin, Split	4	

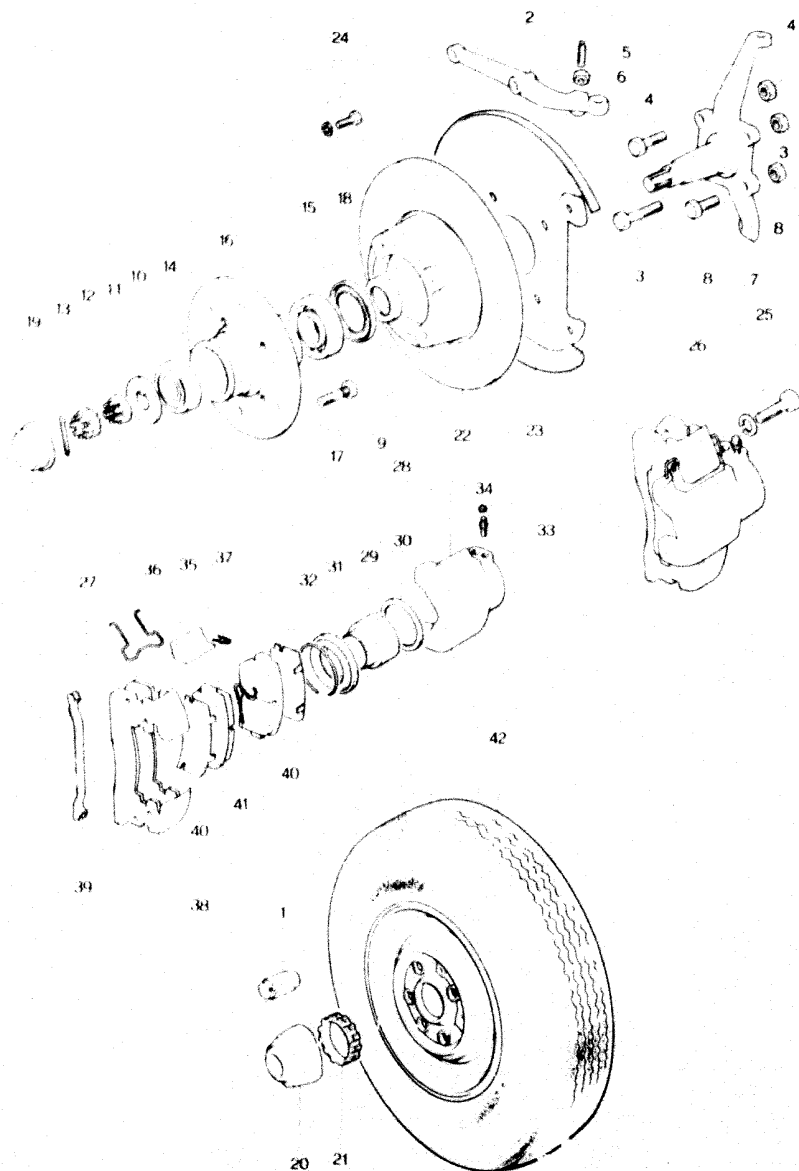

No.	Part Number	Description	Q'ty	Remarks
1	1854 26 161B	Nut, Hub	12	
2	3874 32 301	Arm (R), Knuckle	1	
	3874 32 311	Arm (L), Knuckle	1	
3	99750 11260	Bolt, Steering Knuckle	2	
	99942 1200	Nut, Self Lock	2	
4	99750 11270	Bolt, Steering Knuckle	2	
	99942 1200	Nut, Self Lock	2	
5	99885 1040	Bolt, Stopper	2	
6	99922 1000	Nut, Stopper	2	
7	0223 33 021B	Knuckle (R), Steering	1	
	0223 33 031B	Knuckle (L), Steering	1	
8	99611 1030	Bolt, Steering Knuckle	4	
	99942 1000	Nut, Self Lock	4	
9	0110 33 041	Spacer, Steering Knuckle	2	
10	99977 1845	Washer, Front Wheel	2	
11	0662 33 042	Nut, Front Wheel	2	
12	0662 33 049	Cover, Set	2	
13	99221 4030	Pin, Split-Front Wheel	2	
14	99603 0204	Bearing, Front Wheel Outer	2	

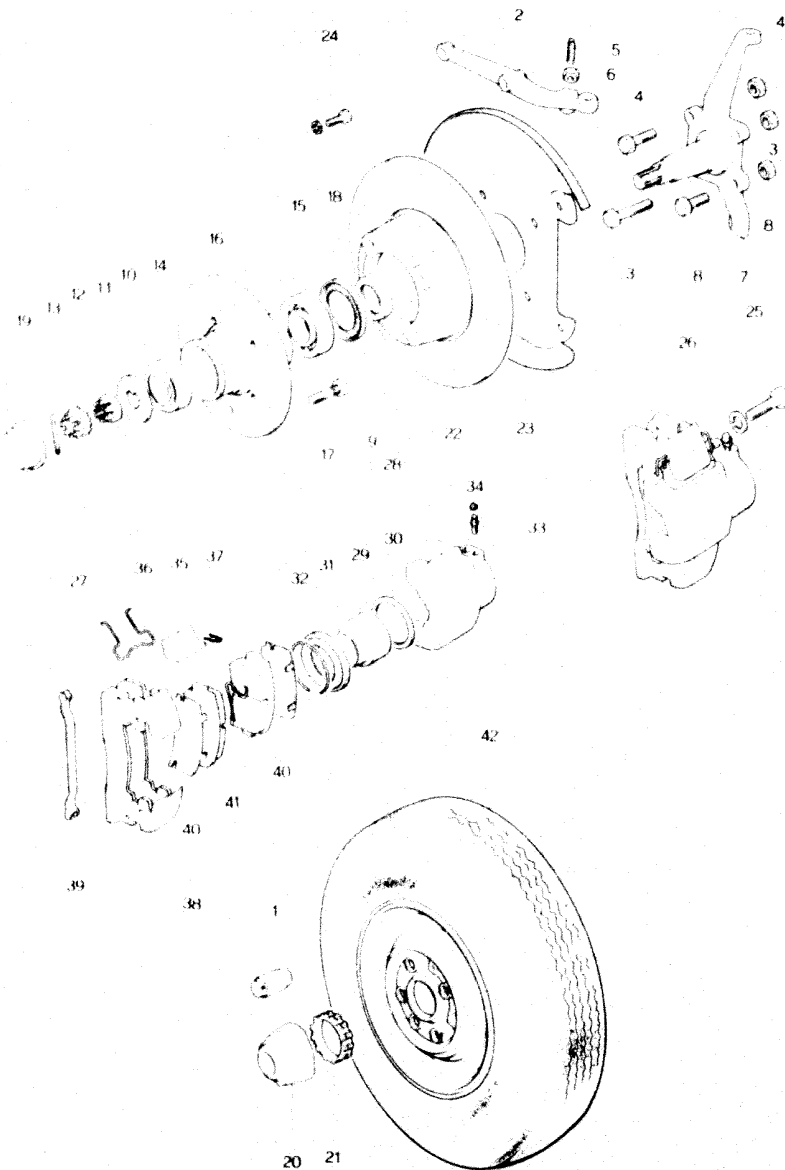

No.	Part Number	Description	Q'ty	Remarks
15	99603 0206	Bearing, Front Wheel Inner	2	
16	1854 33 061 A	Hub, Front Wheel	2	
17	1854 33 062 A	Bolt, Hub	12	
18	3900 33 065	Oil Seal, Front Wheel	2	
19	1854 33 071	Cap, Hub	2	
20	1854 33 191	Emblem, Center Cap	2	
21	1854 33 192	Rubber, Set	2	
22	1854 33 251	Plate, Disc	2	
23	1854 33 260	Adapter (R), Mounting	1	
	1854 33 270	Adapter (L), Mounting	1	
24	0221 33 698	Bolt, Disc Plate	8	
	99971 1000	Washer, Spring	8	
25	0305 33 699	Bolt, Disc Brake	4	
	99971 1200	Washer, Spring	4	
26	3874 33 980	Brake (R), Disc	1	
	3874 33 990	Brake (L), Disc	1	
27	3874 33 280	Support, Mounting	2	
28	3874 33 610	Caliper (R) (Fig No 29 - 34 included)	1	

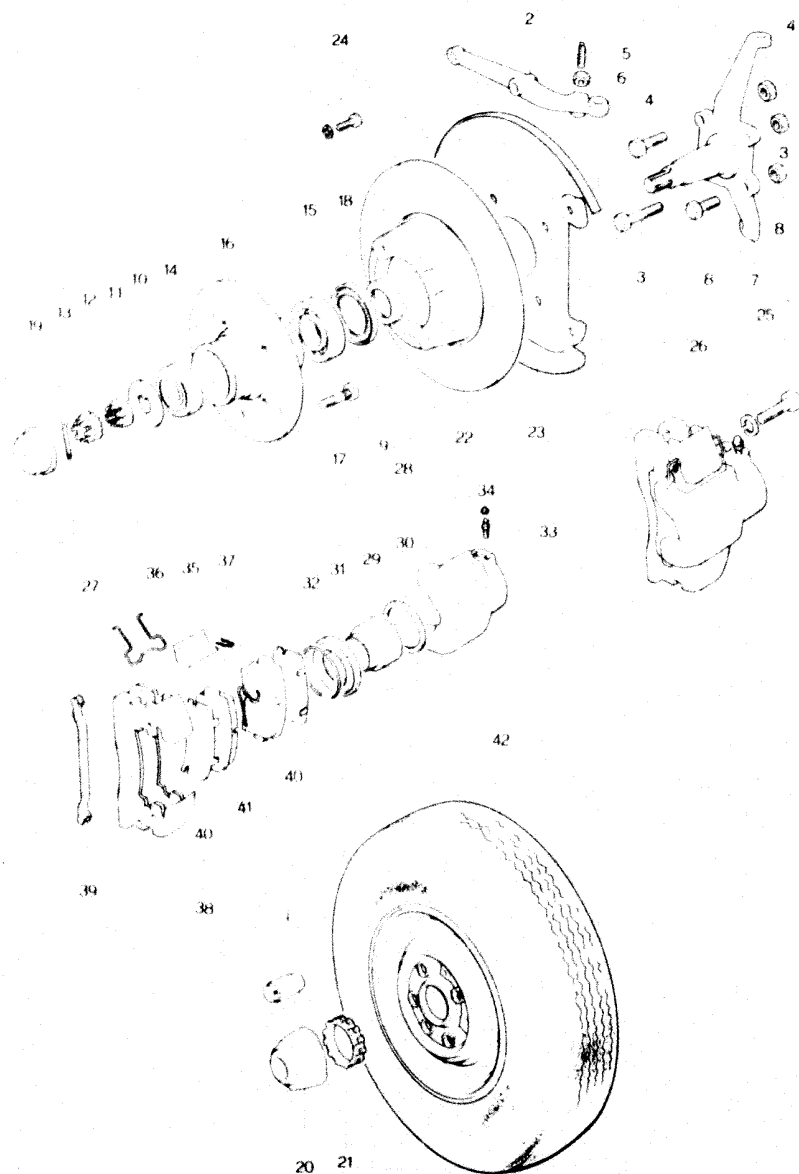

No.	Part Number	Description	Q'ty	Remarks
	3874 33 710	Caliper (L) (Fig No 29 - 34 included)	1	
29	2981 33 651	Piston	2	
30	2981 33 671	Seal, Piston	2	
31	2981 33 681 A	Boot	2	
32	0305 33 685 A	Ring, Boot	2	
33	0233 33 691	Screw, Bleeder	2	
34	0600 33 693	Cap	2	
35	0305 33 695	Plug (R), Stopper	2	
	0305 33 695	Plug (L), Stopper	2	
36	0305 33 696	Spring, Anti Rattle	4	
37	0305 33 698 A	Pin	8	
38	0841 49 230 A	Pad Set (Fig No. 39 - 41 included)	2	
39	0305 33 235	Clip, Anti Rattle Pad	4	
40	0305 33 626 A	Shim	4	
41	0296 33 636	Spring (R), Pad	1	
	0296 33 646	Spring (L), Pad	1	
42	9962 03 7314	Tire, 7.35 - 14 6PR	2	
	9963 60 4130	Valve, Air - TR 413	2	
	9965 05 5540	Wheel, Disc - 5 1/2 J x 14WDC	2	

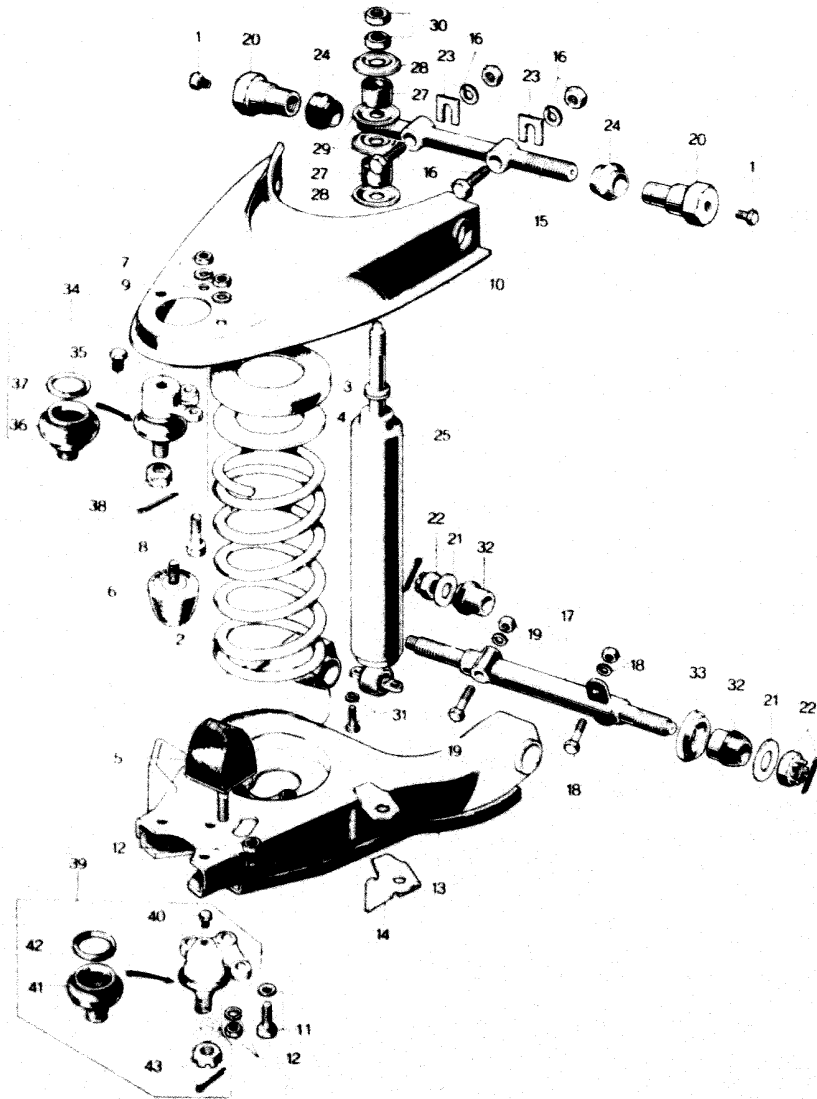

No.	Part Number	Description	Q'ty	Remarks
1	0208 32 278	Plug, Hex - Head	4	
2	3874 34 011	Spring, Coil	2	
4	3874 34 013	Plate, Adjusting	2	
5	0603 34 110C	Stopper, Bumper	2	
6	0603 34 130B	Stopper, Rebound	2	
7	99928 0800	Nut, Rebound Stopper	2	
	99971 0800	Washer, Spring	2	
8	99750 10825	Bolt, Upper Ball Joint	4	
9	99928 0800	Nut	4	
	99971 0800	Washer, Spring	4	
10	3874 34 211	Arm (R), Upper	1	
	3874 34 261	Arm (L), Upper	1	
11	0603 34 305	Bolt, Lower Ball Joint	4	
12	0603 34 307	Nut, Lower Ball Joint & Bumper Stopper	6	
	99958 1022	Washer, Plain - Lower Ball Joint	4	
	99971 1000	Washer, Spring	6	
13	3874 34 310	Arm (R), Lower	1	

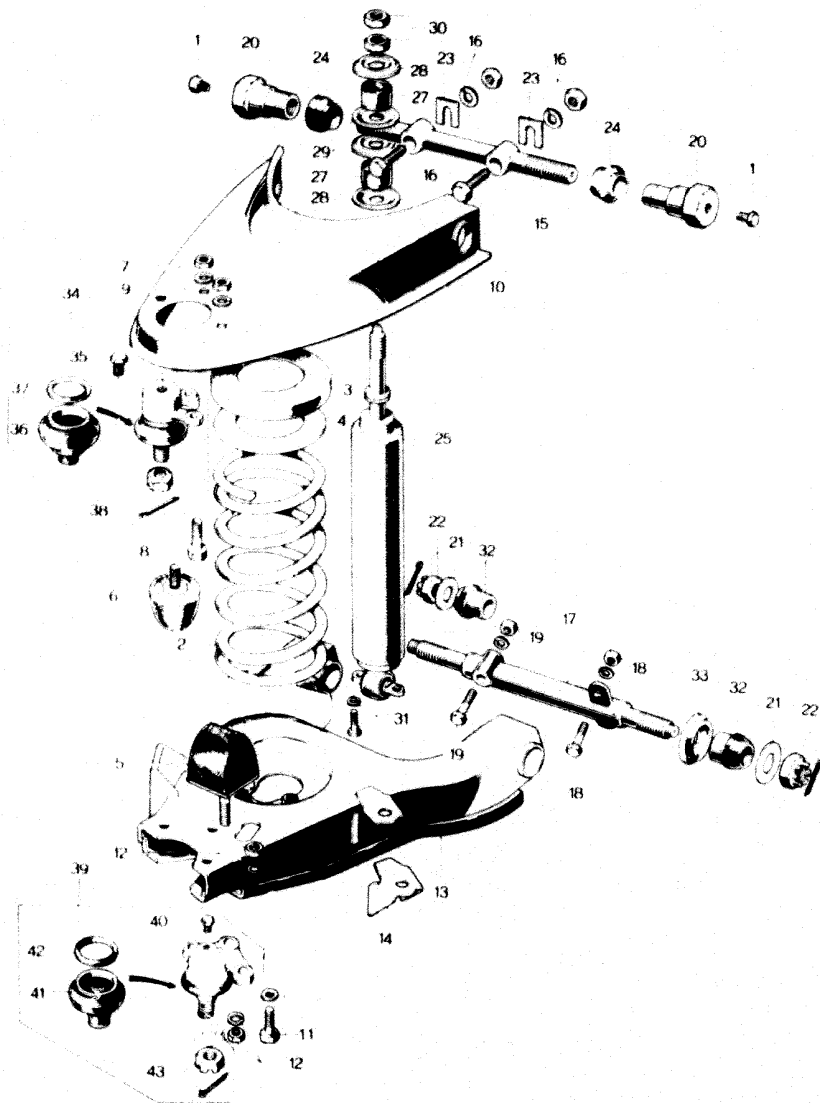

No.	Part Number	Description	Qty	Remarks
	3874 34 360	Arm (L), Lower	1	
14	3874 34 160	Bracket	2	
15	0223 34 411	Shaft, Upper Arm	2	
16	0603 34 416	Bolt, Upper Arm Shaft	4	
	99921 1200	Nut	4	
	99971 1200	Washer, Spring	4	
17	3874 34 431	Spindle, Lower Arm	2	
18	99781 1240	Bolt, Lower Spindle	4	
	99921 1200	Nut	4	
	99971 1200	Washer, Spring	4	
19	99781 1250	Bolt, Lower Spindle	2	
	99921 1200	Nut	2	
	99971 1200	Washer, Spring	2	
20	0662 34 471A	Bush, Thread-Upper Arm Shaft	4	
21	0193 34 662	Washer, Lower Arm Spindle	4	
22	99924 1400	Nut, Lower Arm Spindle	4	
	99221 3025	Pin, Split	4	

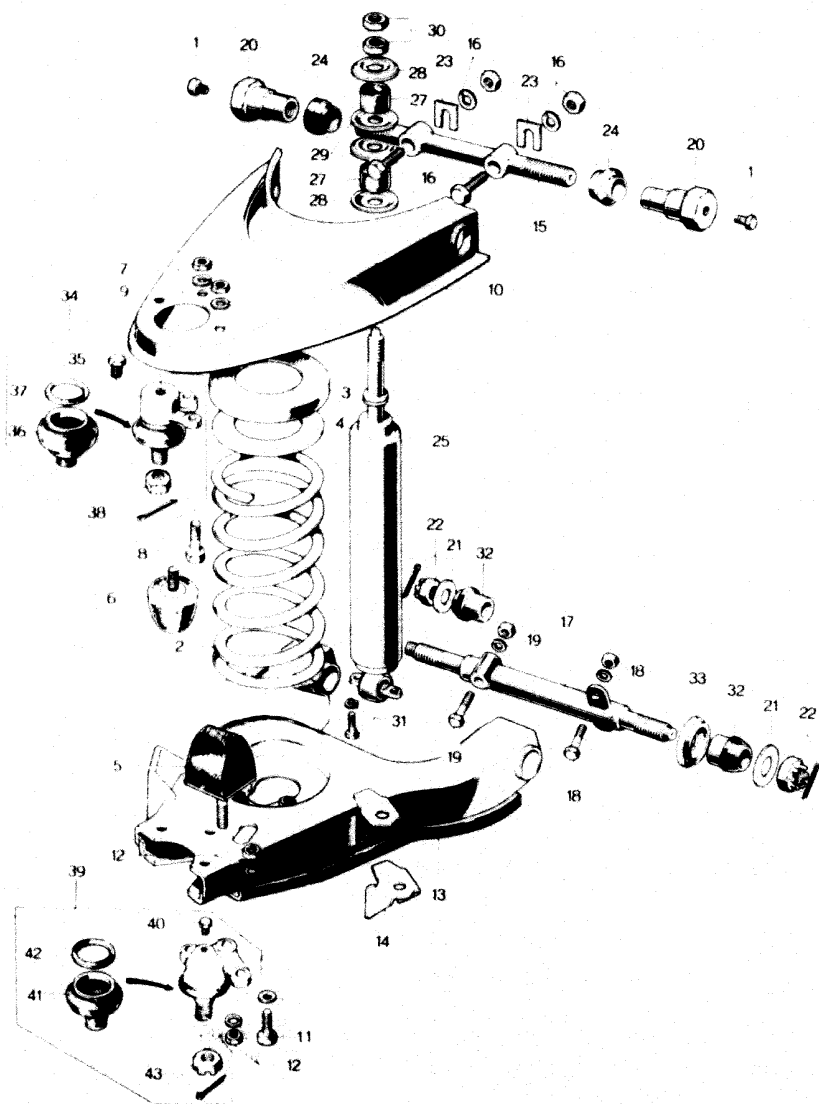

No.	Part Number	Description	Q'ty	Remarks
23	0187 34 665	Shim, Adjust (No. 1)		Selective use 8
	0187 34 666	Shim (No. 2)		
	0187 34 667	Shim (No. 3)		
	0187 34 668	Shim, Adjust (No. 4)		
24	0633 34 673	Seal, Dust-Upper Arm Shaft	4	
25	3874 34 700	Damper, Front	2	
26	0603 34 780	Bush, Rubber	2	
27	0187 34 797	Bush, Rubber	4	
28	0187 34 798	Retainer	4	
29	0187 34 799	Washer, Centering	4	
30	99921 1000	Nut	2	
	99922 1000	Nut	2	
31	99801 0822	Bolt, Front Damper Bush	4	
	99971 0800	Washer, Spring	4	
32	0193 34 820	Bush, Rubber-Lower Spindle	4	
33	0193 34 940	Stopper, Side-Lower Spindle	2	
34	3874 99 354	Joint Set, Upper Ball	2	

FRONT SUSPENSION (SPRING)

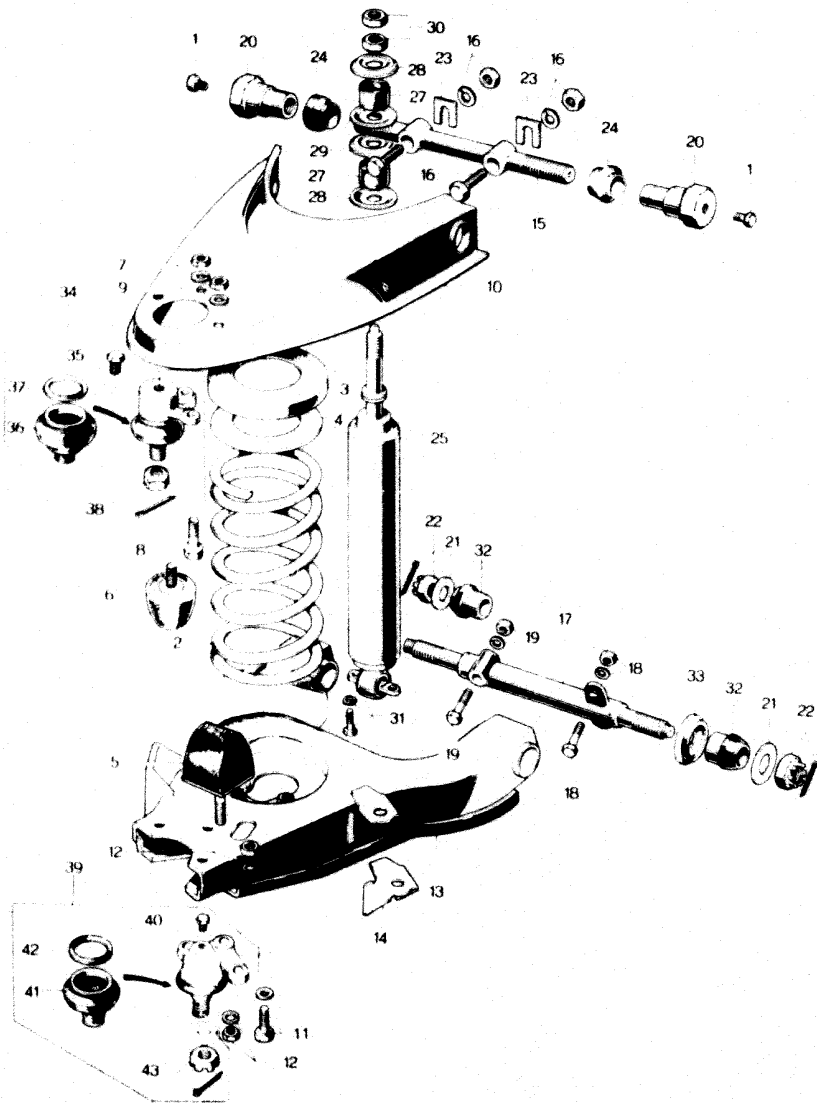

FRONT SUSPENSION (SPRING)

No.	Part Number	Description	Q'ty	Remarks
35	0208 32 278	Plug	2	
36	0187 32 279A	Seal, Dust	2	
37	0187 32 289	Ring Set, Dust Seal	2	
38	99924 1200	Nut	2	
	99221 3020	Pin, Split	2	
39	3874 99 356	Joint Set, Lower Ball	2	
40	0208 32 278	Plug	2	
41	0603 34 515	Seal, Dust	2	
42	0187 34 536	Ring Set, Dust Seal	2	
43	99923 1400	Nut	2	
	99221 3025	Pin, Split	2	

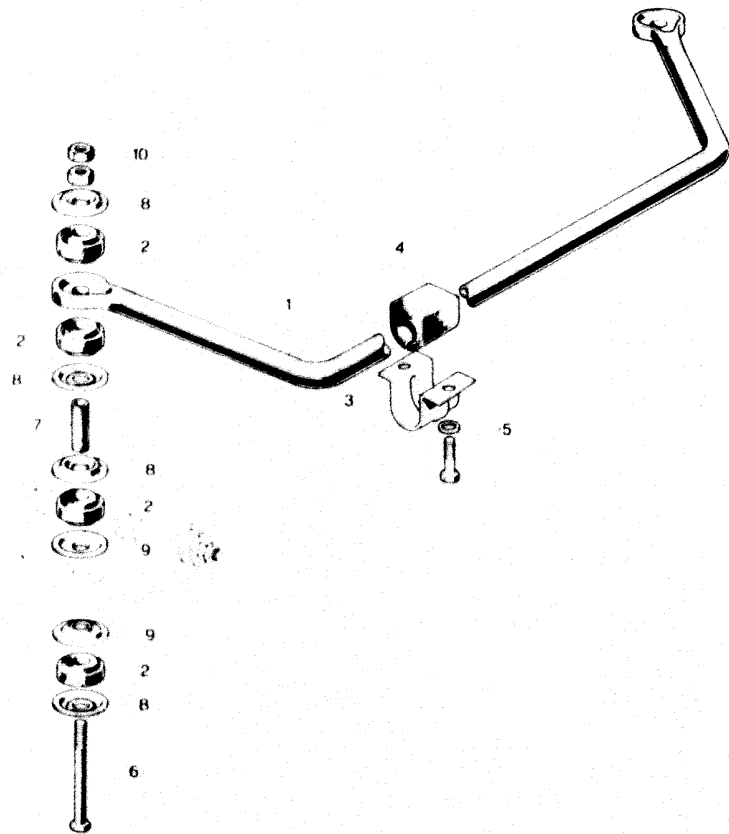

No.	Part Number	Description	Q'ty	Remarks
1	1854 34 151	Bar, Stabilizer	1	
2	0603 34 153	Bush, Rubber	8	
3	0603 34 155	Plate, Stabilizer	2	
4	0603 34 156	Rubber, Stabilizer	2	
5	99794 0830	Bolt, Plate	4	
	99971 0800	Washer, Spring	4	
6	0603 34 157A	Bolt, Stabilizer	2	
7	0603 34 158	Spacer	2	
8	0187 34 776	Retainer	8	
9	0187 34 777	Washer, Centering	4	
10	99921 1000	Nut	2	
	99922 1000	Nut	2	

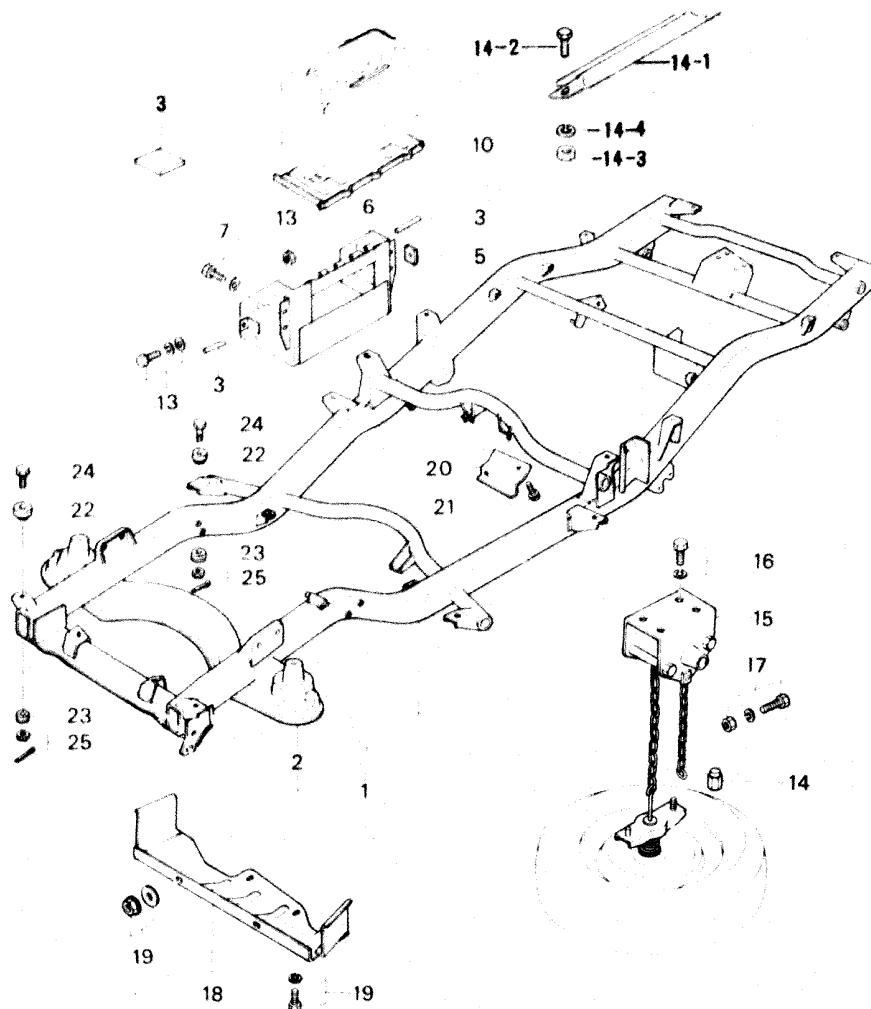

No.	Part Number	Description	Qty	Remarks
1	3790 38 010A	Frame, Main	1	
2	3790 38 200	Member, Cross	1	
3	1859 38 551	Stopper, Battery	2	
4	1854 38 555A	Spring	1	
5	1854 38 558	Rubber	2	
6	3790 38 560	Carrier, Battery	1	
7	99784 1020	Bolt, Battery Carrier	4	
	99951 1022	Washer, Plain	4	
8	1854 38 570C	Cover, Front Battery	1	
9	1854 38 580B	Cover, Upper-Battery	1	
10	3790 38 590	Tray, Battery	1	
11	1854 38 600	Lock, Battery Carrier	1	
12	99940 0803	Nut, Lock	4	
13	99806 0610	Bolt, Battery Carrier	2	
	99952 0600	Washer, Plain	2	
	99971 0600	Washer, Spring	2	
	99911 0600	Nut	2	
14	1854 26 161B	Nut, Hub-Tire Carrier	1	
14-1	3790 38 581	Clamp, Battery Carrier	1	
14-2	0559 66 526C	Set Bolt	2	
14-3	99906 0600	Nut	4	
14-4	99952 0618	Washer	2	

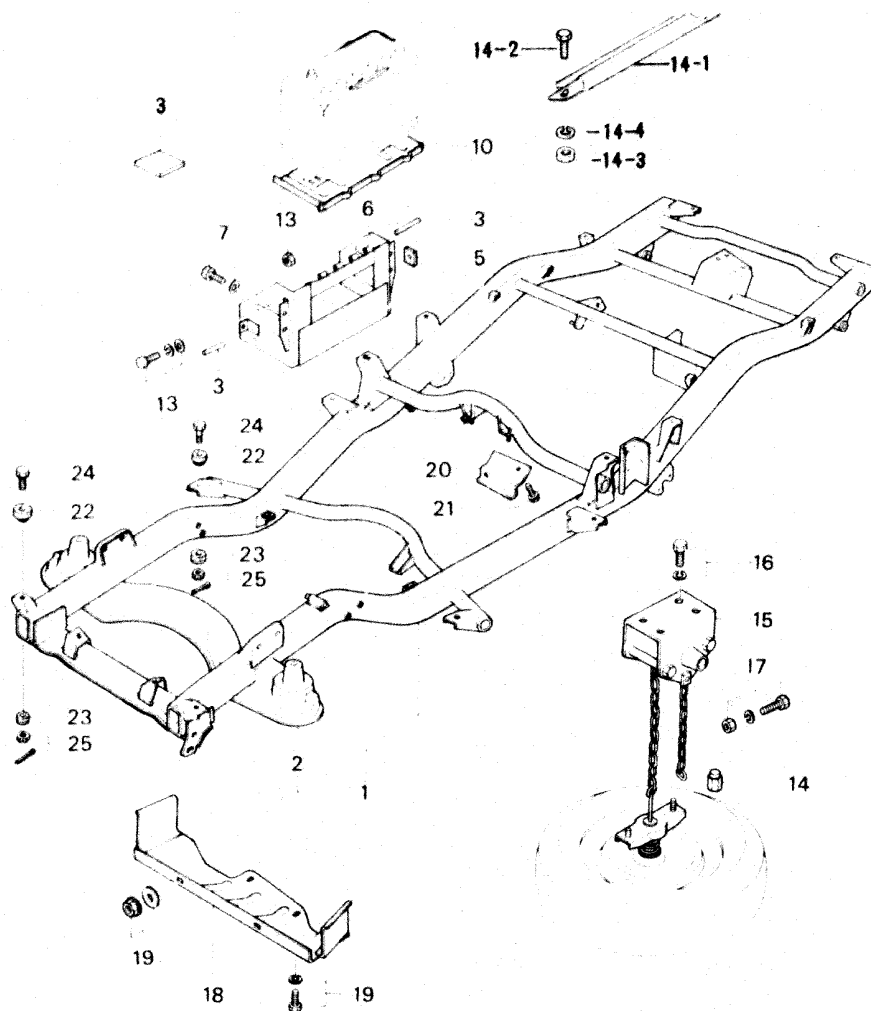

No.	Part Number	Description	Q'ty	Remarks
15	1854 38 610B	Carrier, Tire	1	
	1854 38 650A	Plate, Anchor	1	
	0193 69 770A	Bracket, Hanger	1	
	0600 69 784	Spring, Return	1	
	0727 69 785	Spring, Release	1	
16	99801 0816	Bolt, Tire Carrier	4	
	99971 0800	Washer, Spring	4	
17	99806 0630	Bolt, Tire Carrier	1	
	99906 0600	Nut	1	
	99971 0600	Washer, Spring	1	
18	1854 38 810	Protector, Oil Pan	1	
19	99786 0816	Bolt, Protector	2	
	99952 0800	Washer, Plain	2	
	99971 0800	Washer, Spring	2	
	99940 0800	Nut	2	
20	1854 38 851A	Insulator	1	
21	99796 0612	Bolt, Insulator	2	
22	0603 53 950A	Rubber, Mounting - Upper	6	
23	0603 53 970	Rubber, Mounting - Lower	6	

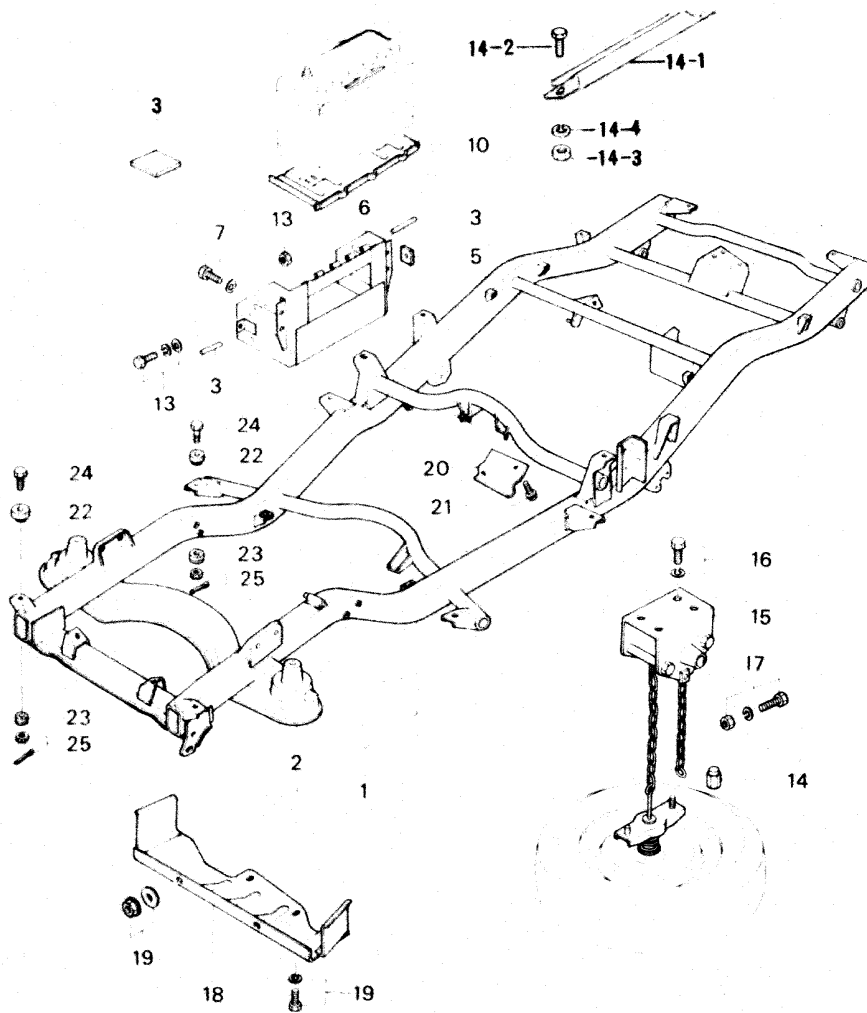

No.	Part Number	Description	Qty	Remarks
24	0603 53 984 A	Bolt, Mount Set	6	
25	99903 0800	Nut, Mount Set	6	
	99951 1030	Washer, Plain	6	
	99221 2015	Pin, Split	6	

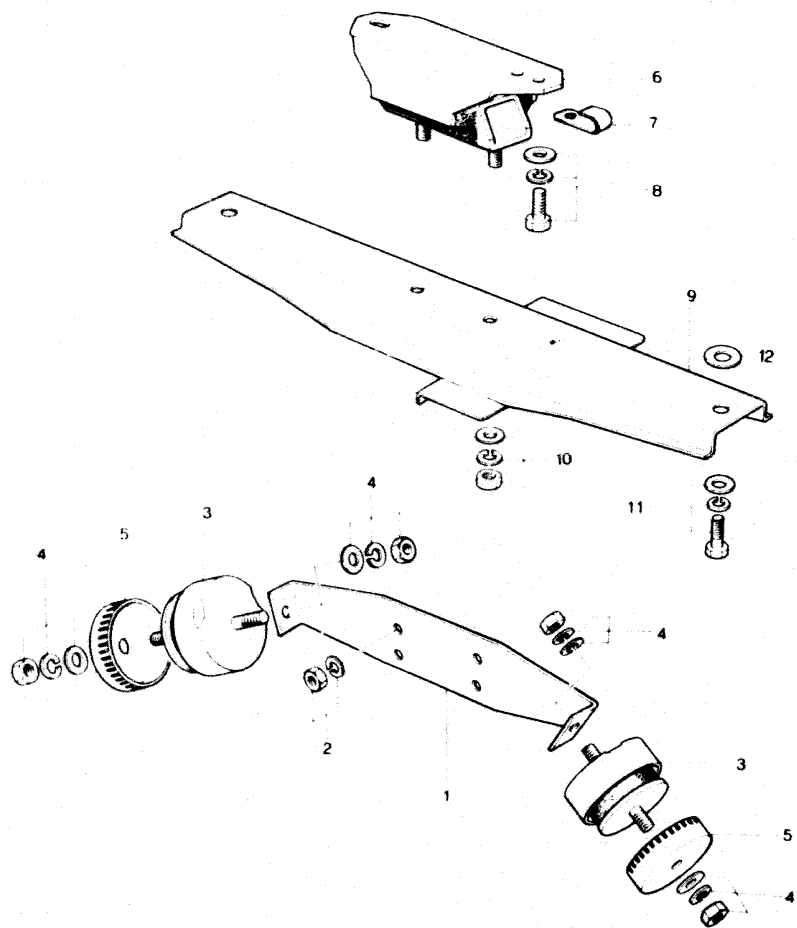

No.	Part Number	Description	Q'ty	Remarks
1	1854 39 020A	Bracket, Engine	1	
2	99921 1000	Nut, Engine Bracket	4	
	99971 1000	Washer, Spring	4	
3	1668 39 040C	Rubber, Engine Mounting	2	
	● 1668 39 040D	Rubber, Engine Mounting	2	77/4 ~ Δ
4	99921 1000	Nut, Engine Mounting Rubber	4	
	99951 1030	Washer, Plain	4	
	99971 1000	Washer, Spring	4	
	0884 39 387	Washer	2	
5	1668 39 045A	Casing, Stopper	2	
	● 1668 39 045B	Casing, Stopper	2	77/5 ~ Δ
6	1011 39 340A	Rubber, Mounting	1	
7	99276 1208	Clip, Mounting Rubber	1	
8	99801 0820	Bolt, Mounting Rubber	2	
	99952 0800	Washer, Plain	2	
	99971 0800	Washer, Spring	2	
9	1854 39 320B	Member, Mounting-T mission	1	
10	99921 1000	Nut, Mounting Member	2	
	99951 1030	Washer Plain	2	
	99971 1000	Washer, Spring	2	
11	99811 1030	Bolt, Mounting Member	2	
	99951 1030	Washer, Plain	2	

No.	Part Number	Description	Q'ty	Remarks
	99971 1000	Washer, Spring	2	
12	99952 1442	Washer, Plain	2	

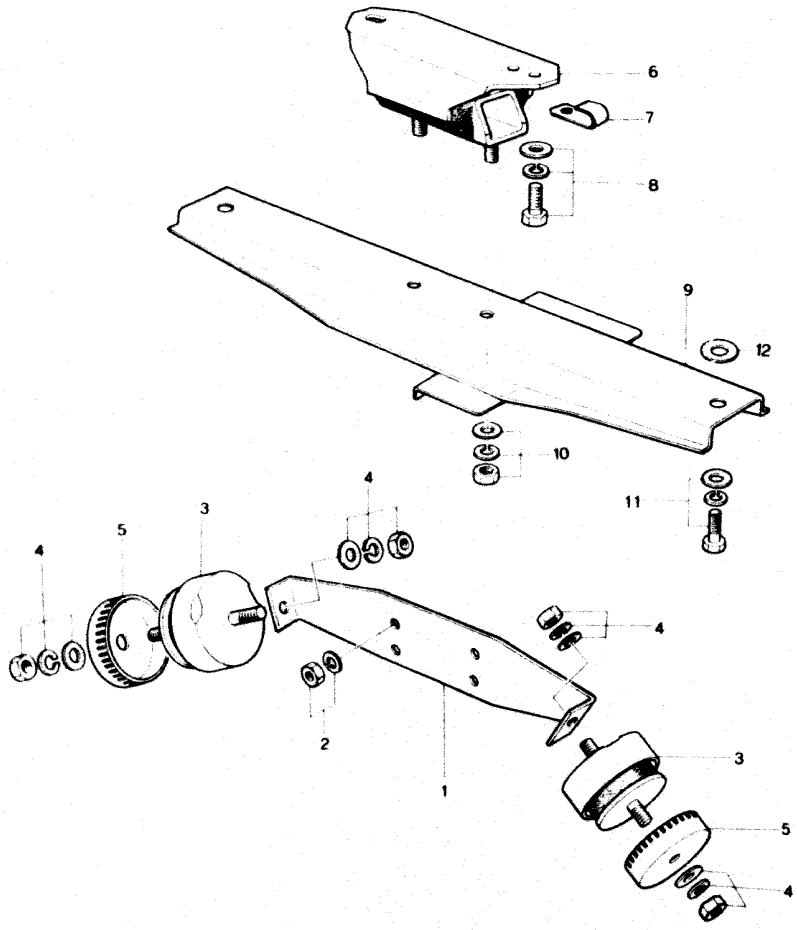

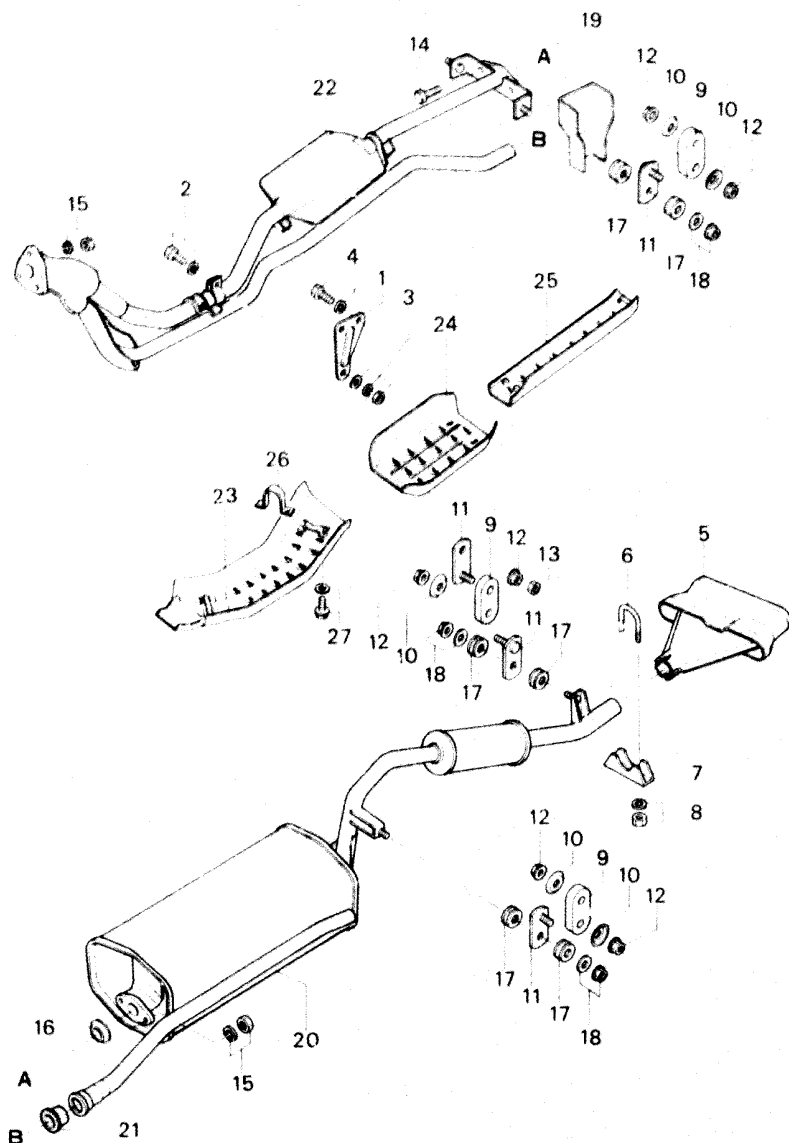

No.	Parr Number	Description	Q'ty	Remarks
1	1854 40 081	Bracket, Pre-Silencer	1	
2	99801 0830	Bolt, Bracket - Pre-Silencer	1	
	99951 0822	Washer, Plain	1	
	99971 0800	Washer, Spring	1	
3	99901 0800	Nut, Bracket	1	
	99951 0822	Washer, Plain	1	
4	99801 0816	Bolt, Bracket	2	
	99971 0800	Washer, Spring	2	
5	3900 40 090	Diffuser, Main Silencer	1	
6	1854 40 096A	Bolt, "U"-Diffuser	1	
7	1854 40 097A	Clamp, "U" Bolt	1	
8	99901 0800	Nut, "U" Bolt	2	
	99971 0800	Washer, Spring	2	
9	3900 40 160	Hanger, Silencer	4	
10	0820 40 166	Washer, Silencer Hanger	8	
11	1114 40 170	Plate, Silencer Hanger	5	
12	99940 0800	Nut, Silencer Hanger	9	
13	99901 0800	Nut, Plate	1	
14	99801 1045	Bolt, Pre-Silencer	2	
15	2158 40 355	Nut, Silencer	5	

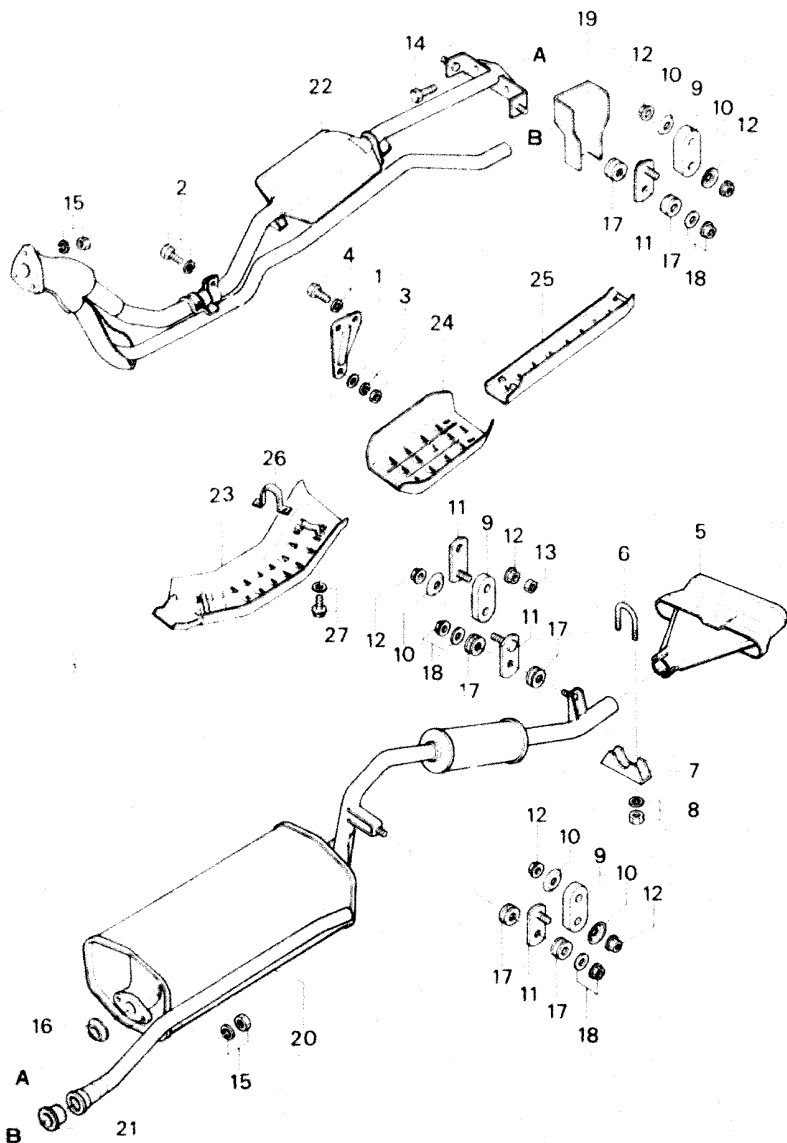

No.	Part Number	Description	Qty	Remarks
	99971 1000	Washer, Spring	5	
16	1757 40 356	Gasket, EX Pipe	1	
17	0824 40 401	Insulator, Silencer, Hanger, Plate	8	
18	99949 0800	Nut, Silencer, Hanger	4	
	99951 0822	Washer, Plain	4	
19	1854 40 405	Insulator	2	
●	1854 40 405A	Insulator	2	77/2 ~ Δ
20	3900 40 500B	Silencer, Main	1	
21	2090 40 508A	Joint, Rubber - Silencer	1	
22	3790 40 600A	Silencer, Pre-	1	
23	1854 40 810C	Protector, No. 1	1	
24	1854 40 821A	Protector, No. 2	1	
25	3790 40 830	Protector, No. 3	1	
26	1114 40 850B	Band, Protector	3	
27	99796 0612	Bolt, Protector	14	
	99952 0618	Washer, Plain	14	

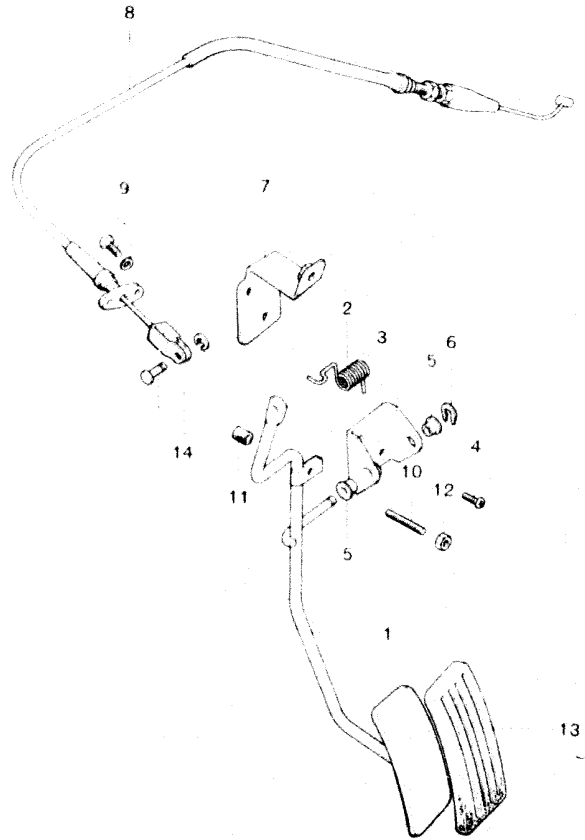

No.	Part Number	Description	Q'ty	Remarks
1	1854 41 610B	Pedal, Accel.	1	
2	2158 41 619	Spring	1	
3	0305 41 641	Retainer, Accel Rod	1	
4	99786 0616	Screw, Tapping - Retainer	2	
5	0259 41 644	Bush	2	
6	99575 0600	Ring, Retaining	1	
7	1856 41 650	Retainer, Accel. Rod (Automatic)	1	
8	1854 41 660C	Cable, Accel.	1	
9	99786 0620	Screw, Tapping - Accel Cable	2	
	99952 0618	Washer, Plain	2	
10	0118 41 681	Stop, Pedal	1	
11	0118 41 682	Rubber, Stopper	1	
12	99940 0600	Nut, Stopper	1	
13	3792 41 711A	Pad, Pedal	1	
14	99230 0511	Pin, Joint Cable & Pedal Rod	1	
	99575 0300	Ring, Snap	1	

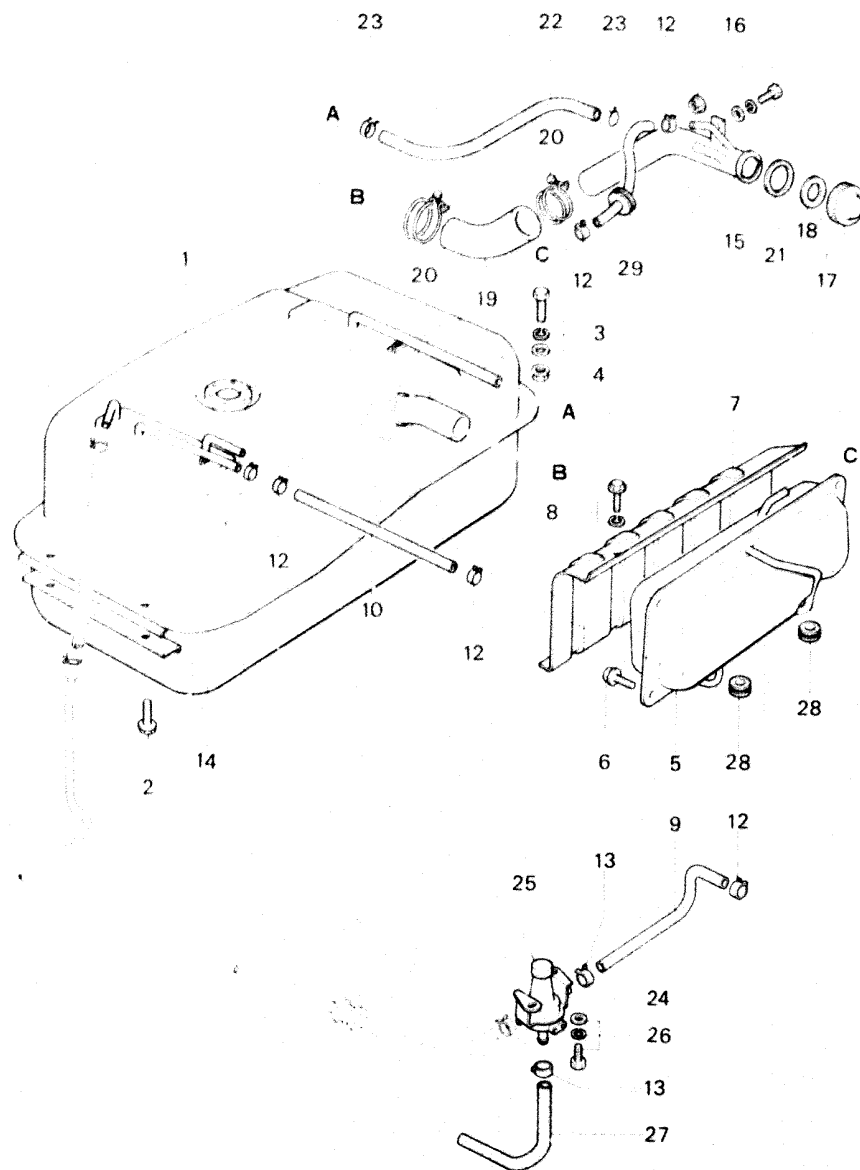

No.	Part Number	Description	QTY	Remarks
1	3787 42 310A	Tank, Fuel	1	
2	99786 0820	Bolt, Fuel Tank - Front Side	2	
3	99601 0820	Bolt, Fuel Tank - Rear Side	2	
	99952 0800	Washer, Plain	2	
	99971 0800	Washer, Spring	2	
4	99940 0802	Nut, Fuel Tank - Rear Side	2	
5	1854 42 330	Tank, Condense	1	
6	99786 0612	Bolt, Condense Tank	4	
7	1854 42 338A	Protector, Condense Tank	1	
8	99786 0616	Bolt, Protector	(Fed. Manual) 7	
	99971 0600	Washer, Spring	7	
9	1854 42 339A	Hose, Condense Tank - Check Valve	1	
10	99348 06340	Hose, Condense Tank - Fuel Tank (ℓ - 340%)	1	Ord By 99349 06750 (ℓ - 1.75m)
11	99336 06030	Hose, Condense Tank - Filler Pipe	1	
	99340 60300	Hose, Condense Tank - Filler Pipe	1	Selective use (Fed. Automatic)
	99348 06200	Hose, Condense Tank - Filler Pipe (ℓ - 200%)	1	Ord By 99349 06750 (Fed. Manual) (ℓ - 1.75m)
12	99283 1000	Clip, Hose - Tank Side	5	
13	99283 1100	Clip, Hose - Check Valve Side	2	
14	1854 42 342A	Seat, Fuel Tank	2	
15	3787 42 350	Pipe, Filler	1	

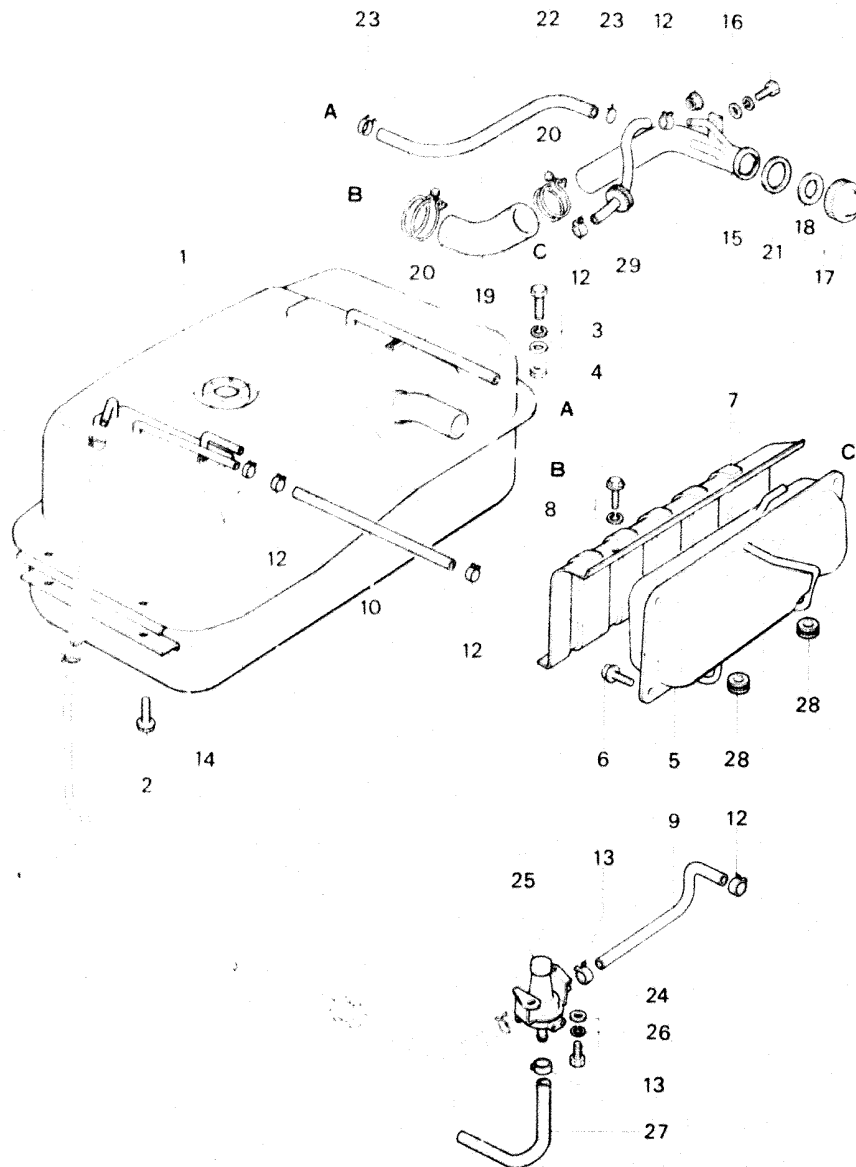

No.	Part Number	Description	Qty	Remarks
16	99801 0816	Bolt, Filler Pipe	1	
	99952 0800	Washer, Plain	1	
	99971 0800	Washer, Spring	1	
	99940 0800	Nut	1	
17	1823 42 430	Cap, Filler	1	
18	0136 42 434	Gasket	1	
19	3870 42 441	Hose, Filler	1	
20	99282 5800	Clamp, Hose-Filler Hose	2	
21	0136 42 449	Supporter, Filler Pipe	1	
22	3900 42 451	Hose, Filler Pipe Fuel Tank	1	
23	99282 2201	Clamp, Hose-Filler Hose	2	
24	3648 42 910	Valve, Check	1	
25	1854 42 717	Cap, Check Valve	1	
26	99797 0512	Bolt, Check Valve	1	
	99952 0500	Washer, Plain	1	
	99971 0500	Washer, Spring	1	

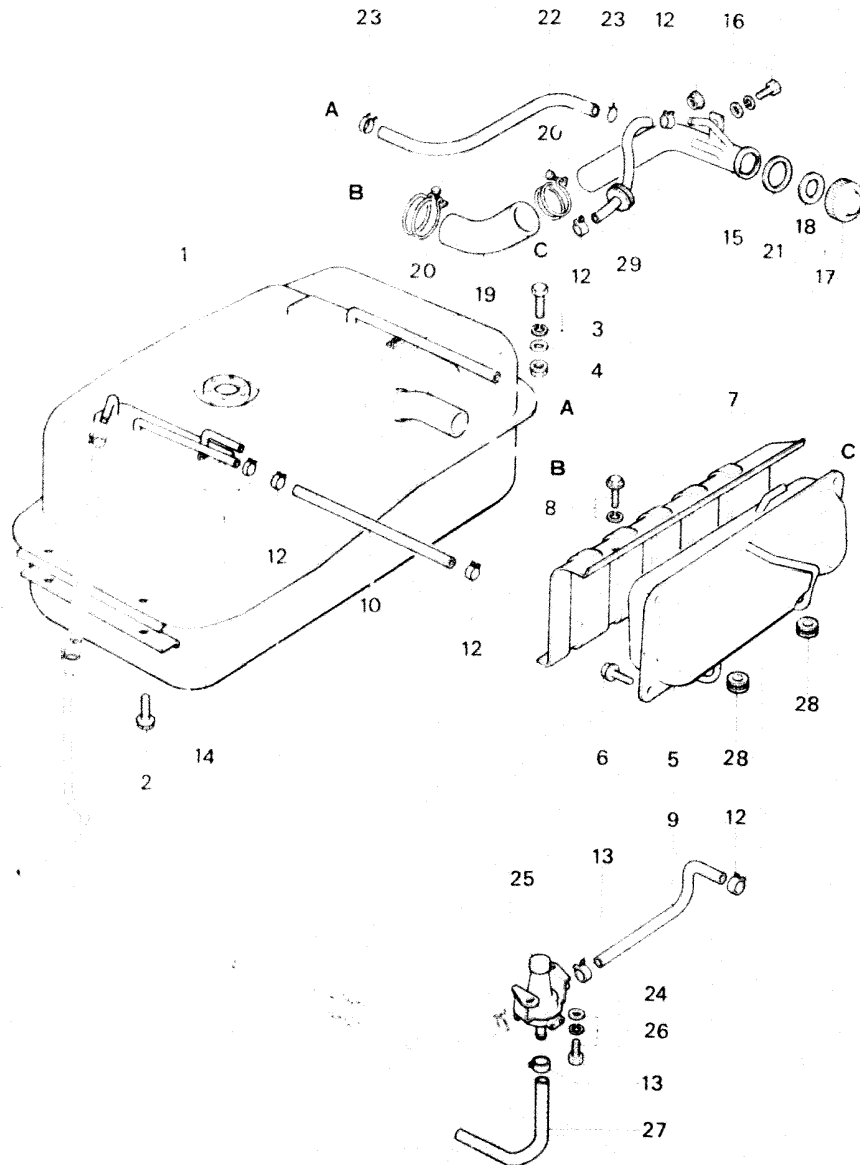

No.	Part Number	Description	Qty	Remarks
27	99348 0628	Hose, Check Valve Floor (ℓ 360%)	1	Ord By 99349 06750 (ℓ 1.75m)
28	99681 1001	Protector, Condense Tank Pipe (Fed. Manual)	2	
29	99681 1501	Protector, Hose (Fed. Manual)	1	

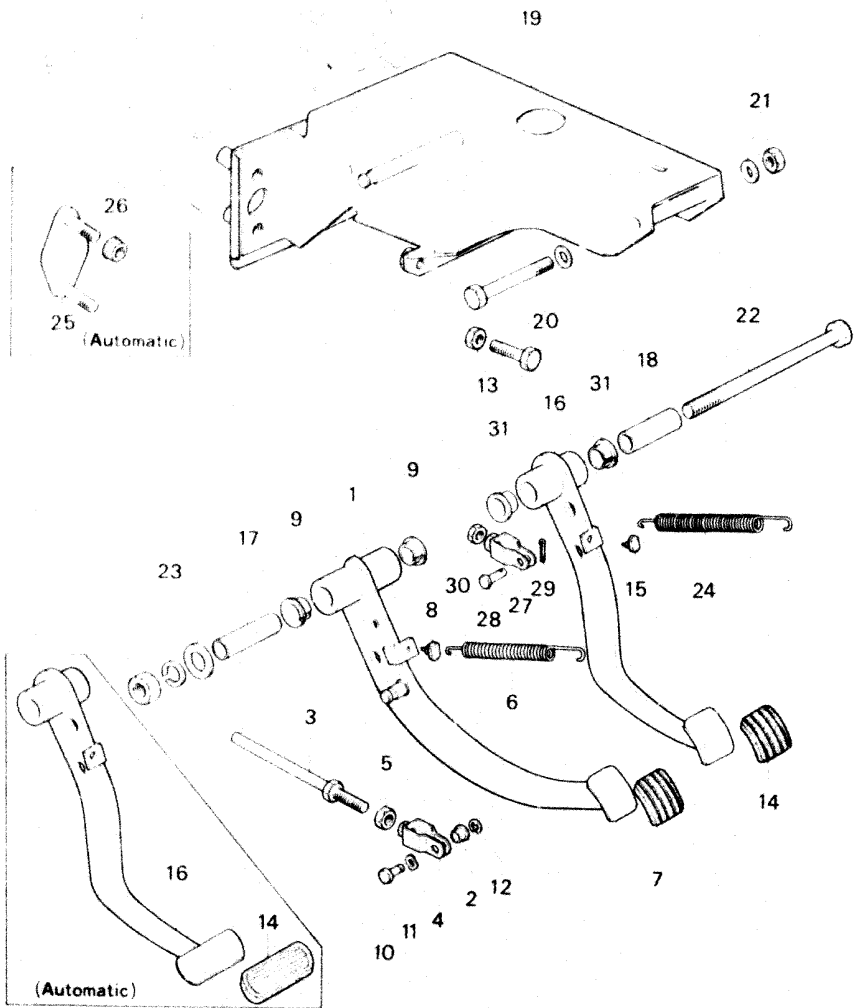

No.	Part Number	Description	Q'ty	Remarks
1	1854 41 030A	Pedal, Clutch	1	
2	0727 41 023	Bush Push Rod Fork - Clutch	1	
3	0824 41 131	Rod, Push - Clutch	1	
4	1872 41 140	Fork, Push Rod	1	
5	1872 41 142	Nut, Push Rod	1	
6	0180 41 308	Spring, Clutch Pedal	1	
7	3792 43 028	Pad, Pedal - Clutch	1	(Manual)
8	0187 43 029	Stopper, Pedal	1	
9	1015 46 085	Bush, Pedal	2	
10	0223 46 683	Pin	1	
11	99972 0800	Washer, Wave	1	
12	99575 0600	Ring, Retaining	1	
13	99795 1032	Bolt, Pedal Stopper	1	
	99922 1000	Nut	1	
14	3792 43 028	Pad, Pedal - Brake (Manual)	1	
	0225 43 028A	Pad, Pedal - Brake (Automatic)	1	
15	0187 43 029	Stopper, Pedal - Brake Pedal	1	
16	1854 43 030B	Pedal, Brake (Manual)	1	
	1856 43 030A	Pedal, Brake (Automatic)	1	
17	0866 43 061	Pipe (Manual)	1	

41

43

CLUTCH & BRAKE PEDAL

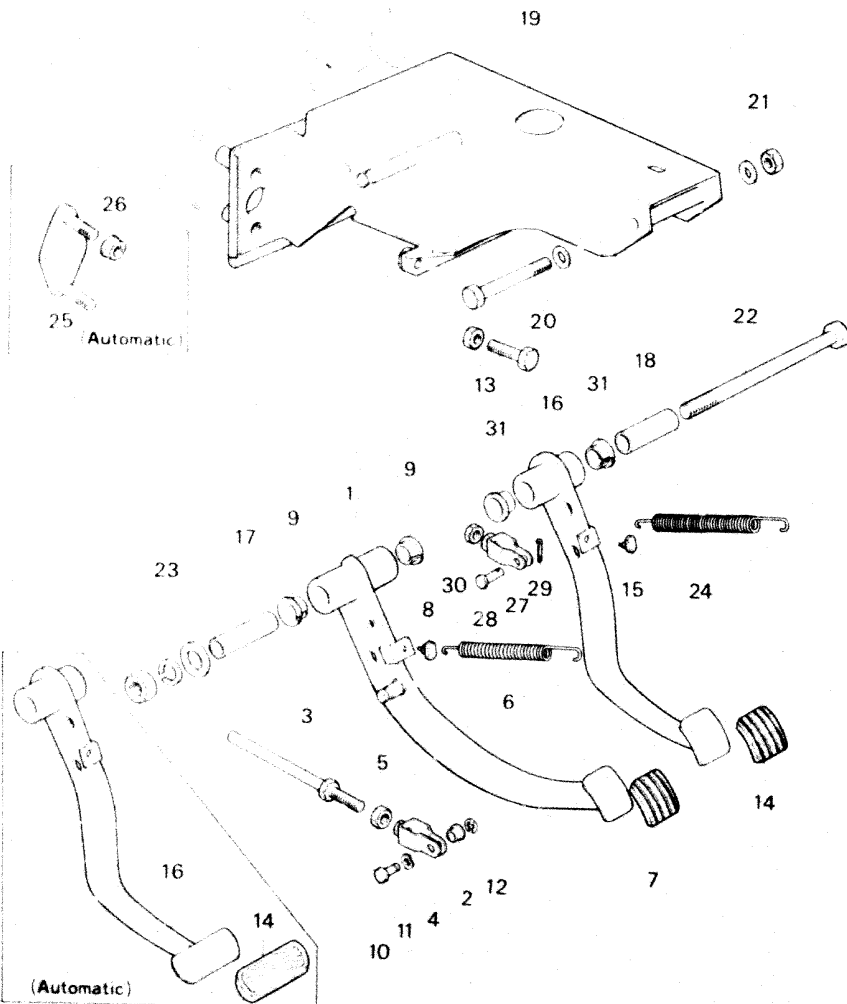

-150-

2-D9

41

43

CLUTCH & BRAKE PEDAL

No.	Part Number	Description	Qty	Remarks
18	0866 43 062	Pipe	1	
19	3790 43 070	Bracket, Master Cylinder	1	
20	99801 0890	Bolt, Bracket	1	
	99952 0822	Washer, Plain	1	
21	99940 0800	Nut, Bracket	1	
	99952 0822	Washer, Plain	1	
22	99813 10180	Bolt, Pedal (Manual)	1	
	99813 10140	Bolt, Pedal (Automatic)	1	
	99952 1000	Washer, Plain	1	
23	99921 1000	Nut, Pedal	1	
	99952 1000	Washer, Plain	1	
	99971 1000	Washer, Spring	1	
24	0603 43 081	Spring, Brake Pedal	1	
25	1015 43 090	Plate, Bracket	1	(Automatic)
26	99940 0800	Nut, Plate	2	
27	1854 43 140	Fork, Brake	1	
28	99231 0822	Pin, Joint-Fork	1	
29	99221 2020	Pin, Split	1	
30	99922 0800	Nut, Fork	1	
31	1015 46 085	Bush, Brake Pedal	2	

-152-

CLUTCH RELEASE & MASTER CYLINDER
(MANUAL)

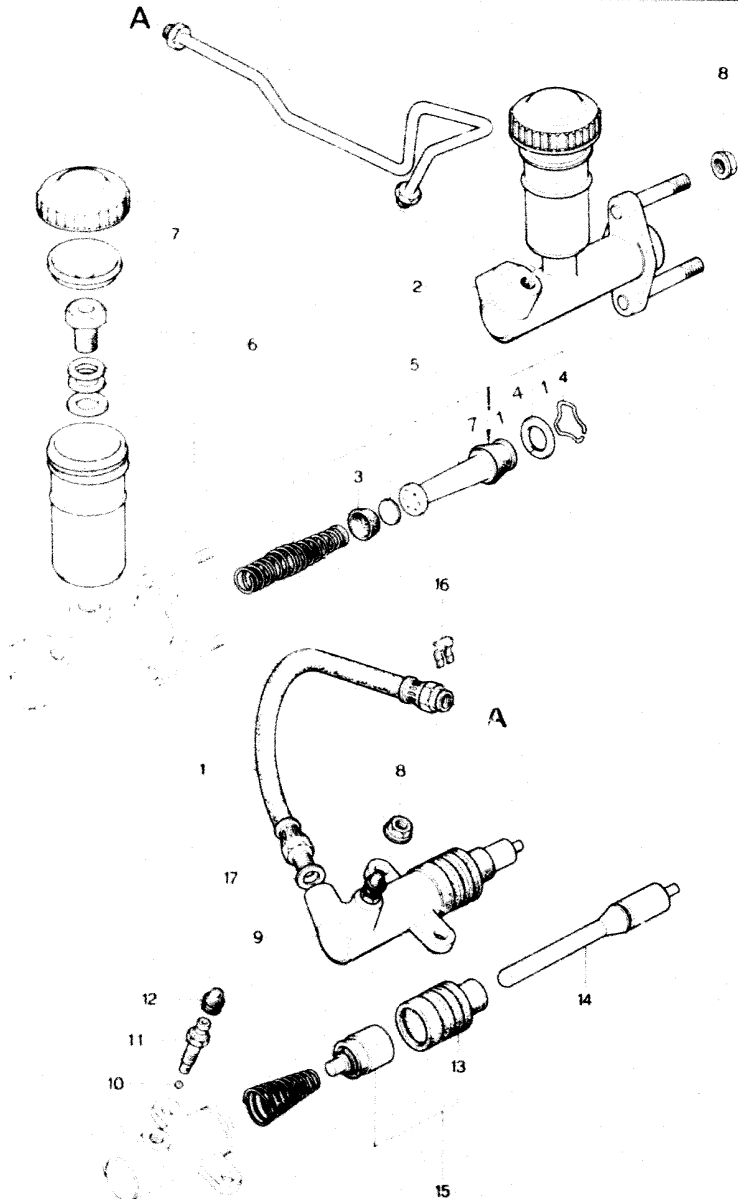

CLUTCH RELEASE & MASTER CYLINDER
(MANUAL)

No.	Part Number	Description	Qty	Remarks
1	0118 41 380A	Hose, Flexible	1	
2	1011 41 400A	Cylinder, Clutch Master	1	
3	0839 41 461	Cup, Primary	1	
4	0111 43 432	Wire, Piston Stop	1	
4-1	0111 43 433	Washer	1	
5	1052 89 411A	Repair Kit	1	
6	0391 89 435	Tank Set, Reserve	1	
7	0317 89 436A	Cup Set, Reserve Tank	1	
7-1	0305 41 451	Cup, secondary	1	
8	99940 0800	Nut, Cylinder	4	
9	1881 41 920A	Cylinder, Clutch Release	1	
10	99611 1500	Ball, Steel	1	
11	0259 33 691	Valve, Bleeder	1	
12	0259 33 693	Cap, Bleeder	1	
13	0603 41 331	Boot	1	
14	1881 41 341	Rod, Push	1	

CLUTCH RELEASE & MASTER CYLINDER
(MANUAL)

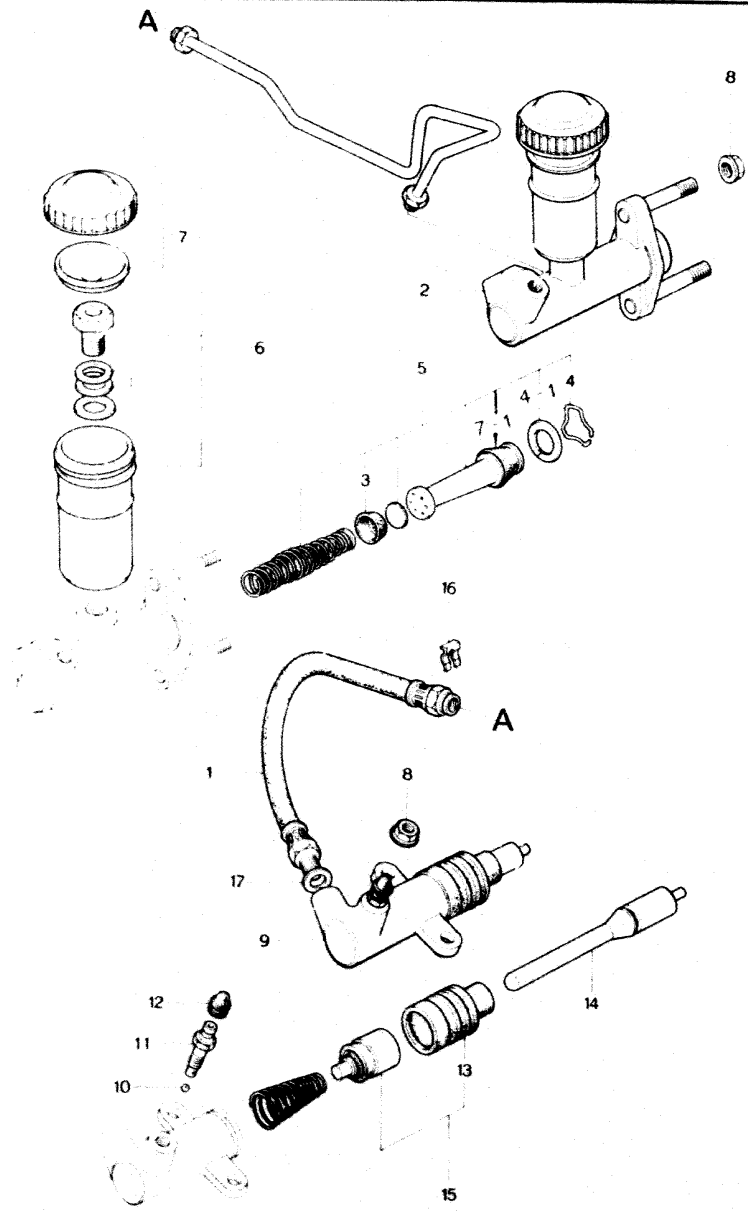

CLUTCH RELEASE & MASTER CYLINDER
(MANUAL)

No.	Part Number	Description	Q'ty	Remarks
-----	-------------	-------------	------	---------

15	1052 89 411 A	Repair Kit	1	
16	0136 43 635	Clip, Flexible Hose	1	
17	99564 1000	Packing, Flexible Hose	1	

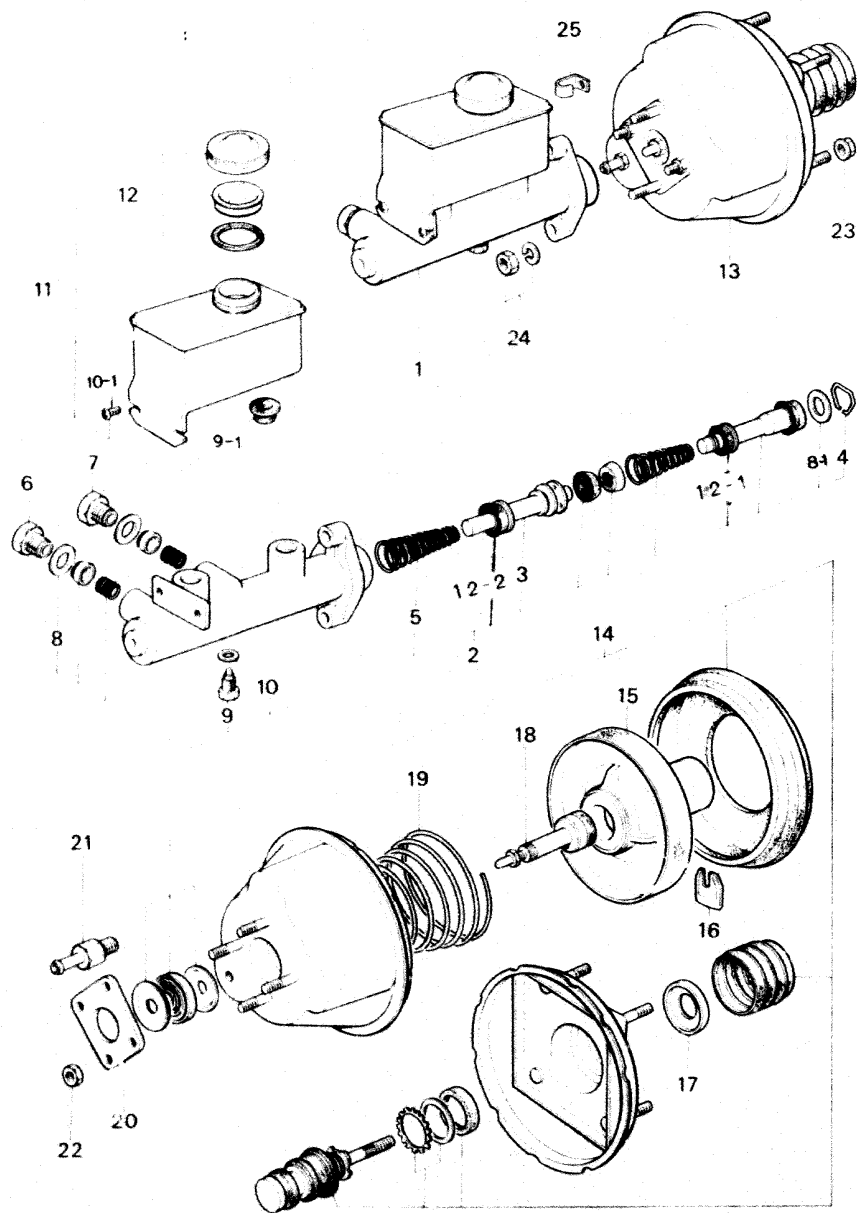

No.	Part Number	Description	Q'ty	Remarks
1	1854 43 400	Cylinder, Tandem Master	1	
2	1708 49 610	Parts Kit, Inner (Fig. No. 3 ~ 5, 8 ~ 10 Included)	1	
3	1708 49 630	Piston, Floating (Fig. No. 5 Included)	1	
4	0305 49 638	Wire, Piston Stop	1	
5	1708 49 642	Spring, Floating	1	
6	0512 49 651	Bolt, Joint	1	
7	0512 49 652	Bolt, Joint	1	
8	0305 49 656	Gasket, Joint Bolt	2	
8-1	0305 49 666	Washer, Stop	Selective Use	1
	0512 49 667	Washer, Stop		
	0512 49 668	Washer, Stop		
9	0512 49 676	Bolt, Set (A)	Selective use	1
	0512 49 677	Bolt, Set (B)		
	0512 49 678	Bolt, Set (C)		
9-1	0305 49 686B	Bush	2	
10	0512 49 696	Gasket, Set Bolt	1	
• 10-1	0391 49 692	Bolt, Tank Set	2	
11	0391 89 435	Tank Set	1	
12	0317 89 436A	Cap Set, Tank	1	
12-1	0305 49 626	Cup, Primary	1	

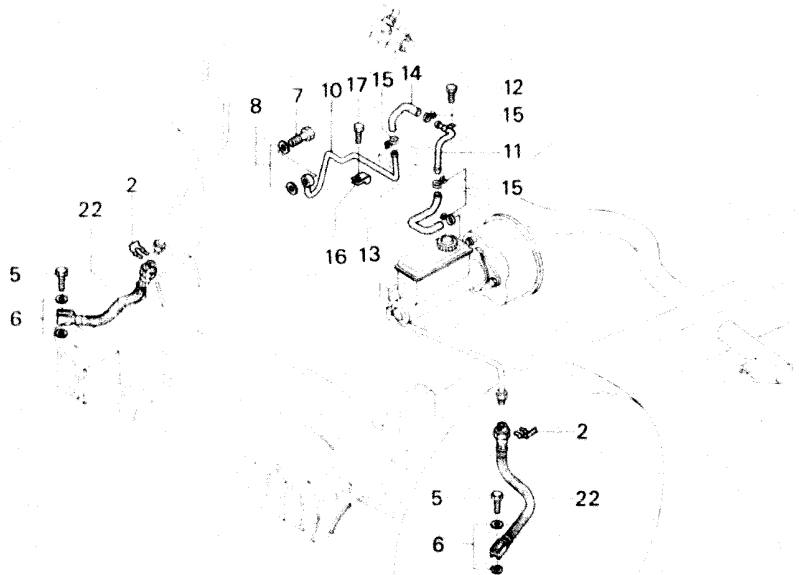
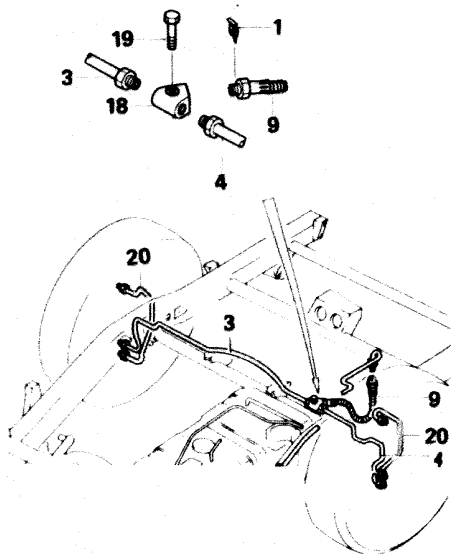

No.	Part Number	Description	Q'ty	Remarks
1	0136 43 635	Clip, Flexible Hose	1	
2	0305 43 635	Clip, Flexible Hose	2	
3	3790 43 650	Pipe, Brake Oil (R)-Rear	1	
4	3790 43 660	Pipe, Brake Oil (L)-Rear	1	
5	1570 43 694A	Bolt, Connector-Front Flexible Hose 2		
6	99562 1000	Gasket	5	
7	1570 43 694 A	Bolt, Connector	1	
8	99562 1200	Gasket, Connector Bolt	2	
9	1854 43 810	Hose, Flexible Rear	1	
10	1757 43 830 A	Pipe, Vacuum	1	
11	1854 43 830	Pipe, Vacuum	1	
12	99796 0610	Bolt, Vacuum Pipe	1	
13	1854 43 836	Hose, Vacuum	1	
14	1854 43 842	Hose, Vacuum	1	
15	99282 1901	Band, Hose-Vacuum Hose	4	
16	1757 43 848	Holder, Pipe	1	
17	99796 0812	Bolt, Pipe Holder	1	
18	0118 43 853	Joint, Pipe-Rear	1	
19	99796 0625	Bolt, Joint	1	
20	3874 43 950	Pipe, Rear-Brake Oil	2	

BRAKE PIPING (WHEEL SIDE)

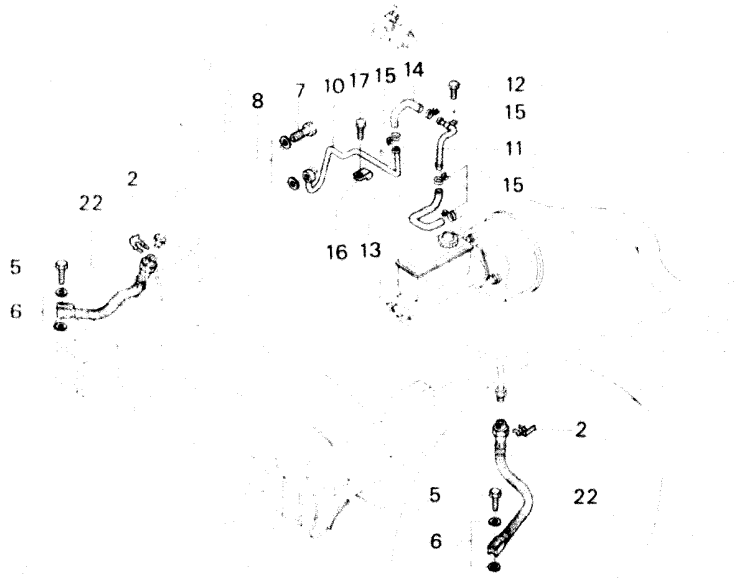
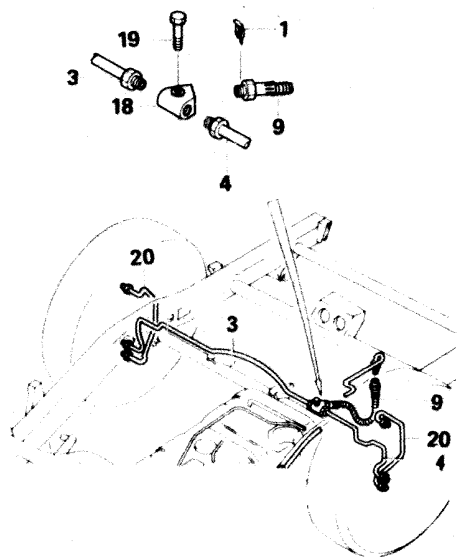

BRAKE PIPING (WHEEL SIDE)

No.	Part Number	Description	Q'ty	Remarks
22	1854 43 970	Hose, Flexible	2	Ord By 1854 43 820
23	0187 45 221	Joint, Pipe-Rear	2	
24	99800 0025	Bolt, Pipe Joint	2	
	99840 0000	Nut	2	

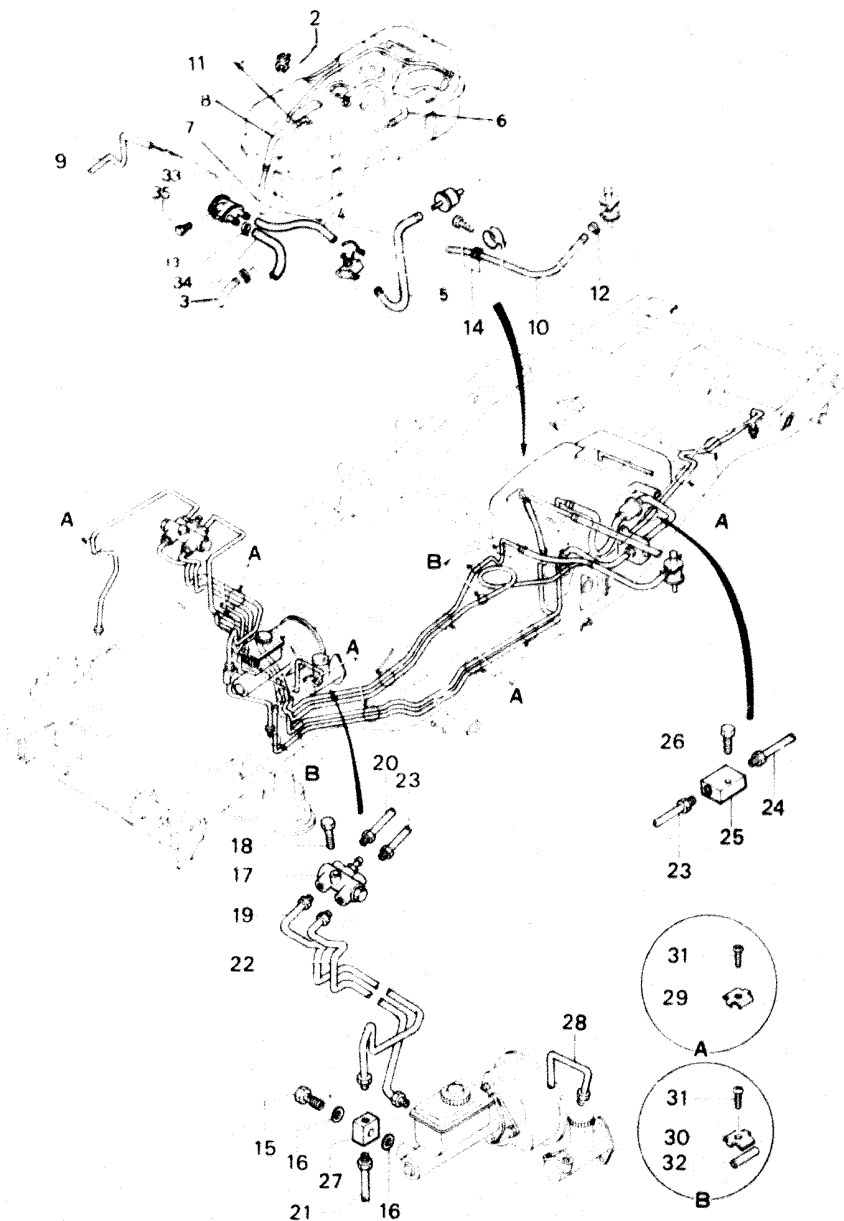

No.	Part Number	Description	Qty	Remarks
2	0707 43 390	Clip	1	
3	3790 45 061	Pipe Fuel Main	1	
4	99348 0826	Hose Fuel Man Man Pipe Fuel Pump 2 318%	1	Ord By 99349 08750 2 1.75m
5	99348 0832	Hose Fuel Man Fuel Pump Fuel Filter	1	
6	99348 0826	Hose Fuel Man Fuel Filter Fuel Tank	1	
7	1854 45 631B	Pipe Fuel Return	1	
8	99348 06290	Hose Fuel Return Return Pipe Fuel Tank 2 250%	1	Ord By 99349 06750 2 1.75m
9	3790 45 731	Pipe Evaporation	1	
10	99348 06570	Hose Evaporation Evaporation Pipe Check Valve 2 318%	1	Ord By 99349 06750 2 1.75m
11	99283 1000	Clip Hose	3	
12	99283 1100	Clip Hose	1	
13	99283 1200	Clip Hose	6	
14	99686 1400	Protector Hose	2	
15	0118 43 505A	Bolt Connector	1	
16	99562 1000	Gasket Connector Bolt	2	
17	1011 43 890A	Indicator Brake Fail	1	
18	99786 0635	Bolt Indicator	1	
19	1854 45 210	Pipe Front Main Brake	1	
20	3790 45 280	Pipe Front Brake (R)	1	

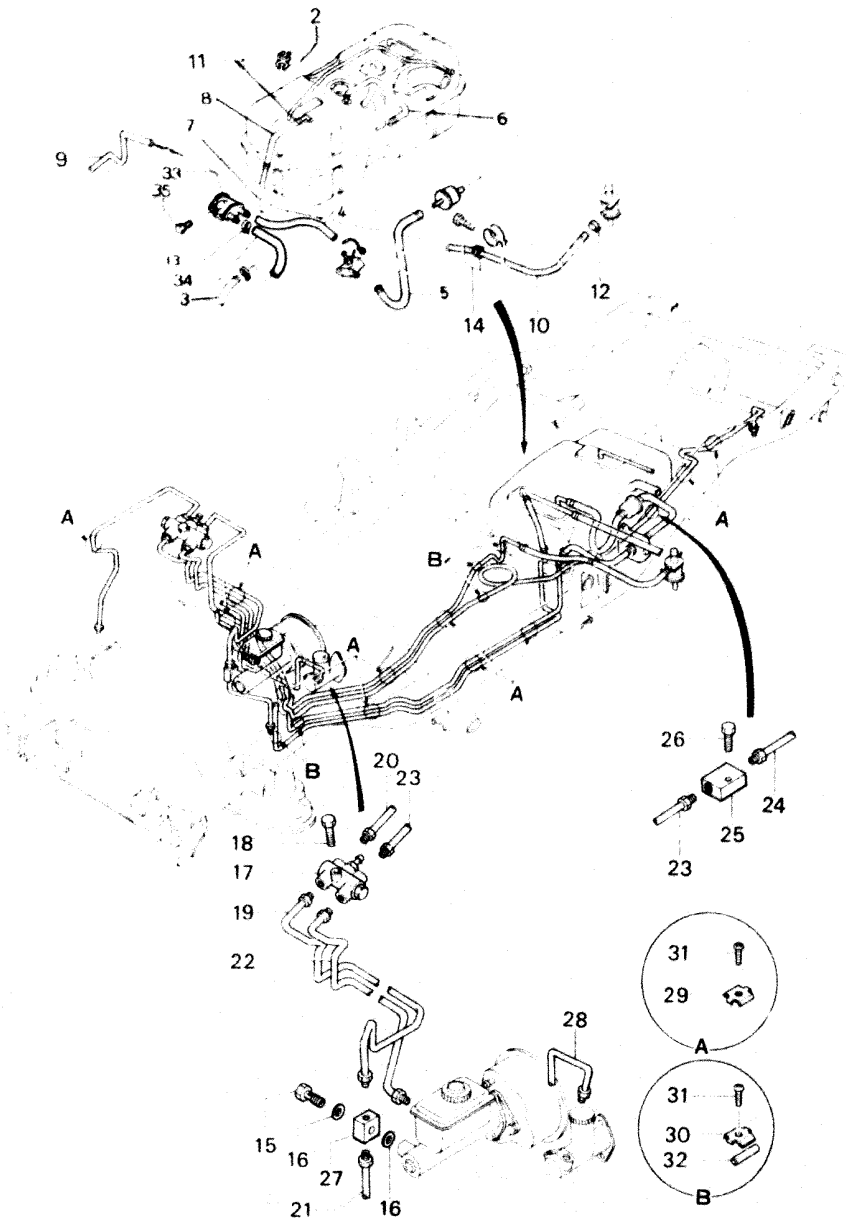

No.	Part Number	Description	Qty	Remarks
21	3790 45 320	Pipe Front Brake (L)	1	
22	1854 45 340	Pipe Rear Main Brake	1	
23	3790 45 350	Pipe Rear Brake No 1	1	
24	3790 45 360	Pipe Rear Brake No 2	1	
25	0571 45 451	Joint Pipe	1	
26	99786 0630	Bolt Pipe Joint	1	
27	0866 45 452	Joint Pipe	1	
28	1854 45 550 A	Pipe Clutch (Manual)	1	
29	0866 45 903 A	Clip Pipe	12	
30	1304 45 903	Clip Pipe	6	
31	99786 0612	Screw	18	
32	1854 45 995	Protector	5	
33	3919 45 170	Valve, Fuel Cut	1	
34	99348 0816	Hose	1	
35	99860 0516	Screw, Tapping	2	

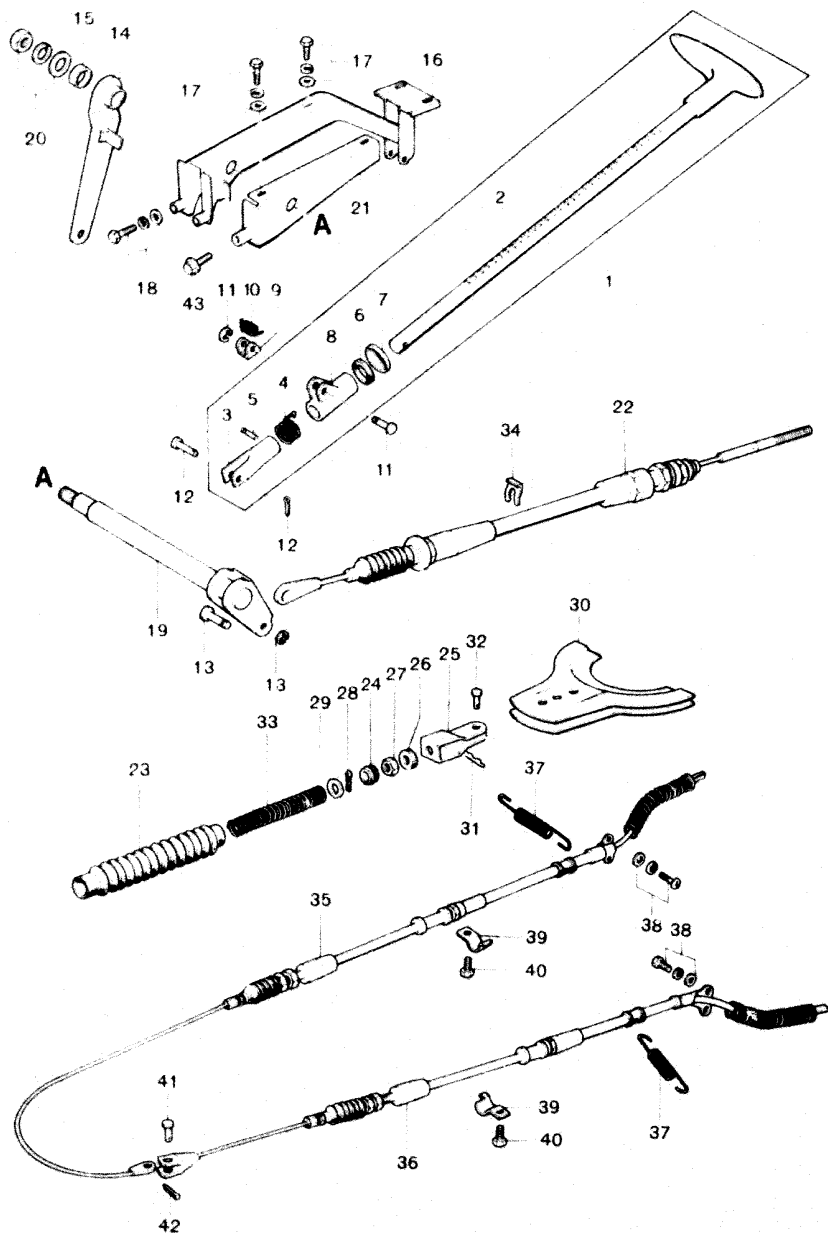

No.	Part Number	Description	Q'ty	Remarks
15	2541 44 063	Spacer	1	
16	1854 44 080	Bracket, Parking Brake	1	
17	99830 0612B	Screw, Bracket	5	
	99953 0600	Washer, Plain	5	
	99971 0600	Washer, Spring	5	
18	99785 0645	Screw, Bracket	2	
	99951 0618	Washer, Plain	2	
	99971 0600	Washer, Spring	2	
19	1845 44 090	Lever, Spindle	1	
20	99922 1000	Nut, Spindle Lever	1	
	99952 1000	Washer, Plain	1	
	99971 1000	Washer, Spring	1	
21	1845 44 110	Bracket, Parking Brake	1	
22	3874 44 150	Cable, Front	1	
23	0603 44 158 A	Boot	1	
24	0603 44 167	Ring, Guide	1	
25	0603 44 261	Joint, Fork	1	
26	0603 44 262	Nut, Adjust	1	
27	99906 0600	Nut	1	

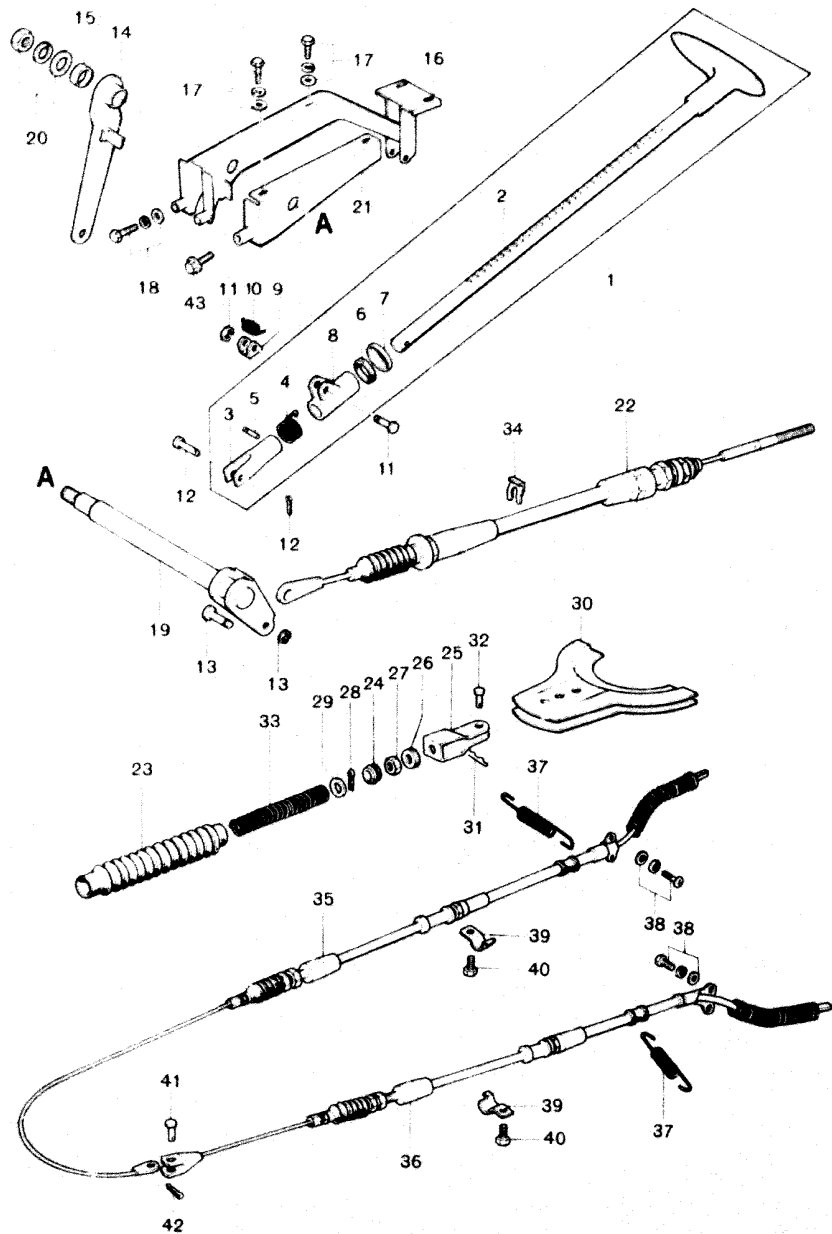

No.	Part Number	Description	Qty	Remarks
28	99221 1610	Pin, Split	1	
29	99203 2000	Washer, Plain	1	
30	0603 44 270	Plate, Equalizer	1	
31	99231 0822	Pin, Joint-Equalizer Plate	1	
32	0603 44 272	Pin	1	
33	0603 44 357	Spring, Joint Fork	1	
34	0118 44 375	Clip, Cable	1	
35	3790 44 410	Cable (R), Rear	1	
36	3870 44 420	Cable (L), Rear	1	
37	0578 44 431	Spring, Cable	2	
38	99833 0510	Screw, Setting Plate	4	
	99952 0500	Washer, Plain	4	
	99971 0500	Washer, Spring	4	
39	0866 44 439	Clip, Rear Cable	2	
40	99786 0616	Screw, Tapping-Clip	2	
41	99231 0620	Pin, Joint Rear Cable	1	
42	99221 1610	Pin, Split-Joint Pin	1	
43	99786 0845	Screw, Tapping-Parking Brake Bracket	1	

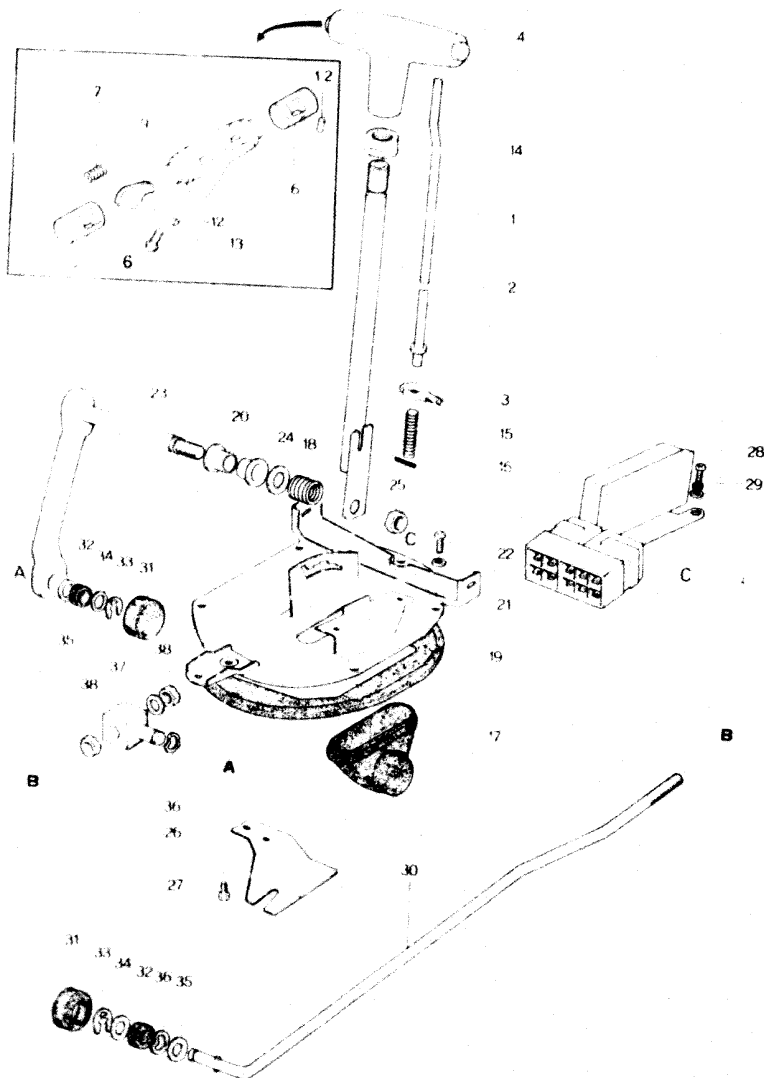

No.	Part Number	Description	Q'ty	Remarks
19	1015 46 083A	Rubber, Seal	1	
20	1015 46 085	Bush, Lever	2	
21	1856 46 110	Bracket, Selector Lever	1	
22	99865 0516	Screw, Lever Bracket	6	
23	1015 46 150A	Lever	1	
24	99953 1400	Washer, Plain	1	
25	99940 1000	Nut, Lever	1	
26	1856 46 201	Insulator, Heat	1	
27	99796 1016	Bolt, Heat Insulator	2	
28	1015 66 520A	Switch, Inhibitor	1	
29	1015 66 520B	Switch, Inhibitor	1	77/9 ~ Δ
29	99763 0610	Screw, inhibitor Switch	2	
30	1856 46 571	Rod	1	
31	1015 46 648	Cover, Dust	2	
32	1015 46 684	Bush	2	
33	99575 0600	Ring, Retaining	2	
34	99952 0816	Washer, Plain	2	
35	99953 0800	Washer, Plain	2	
36	99972 0800	Washer, Wave	2	
37	1015 46 691	Joint, "T"	1	
38	99902 0800	Nut, "T" Joint	2	
	99971 0800	Washer, Spring	1	

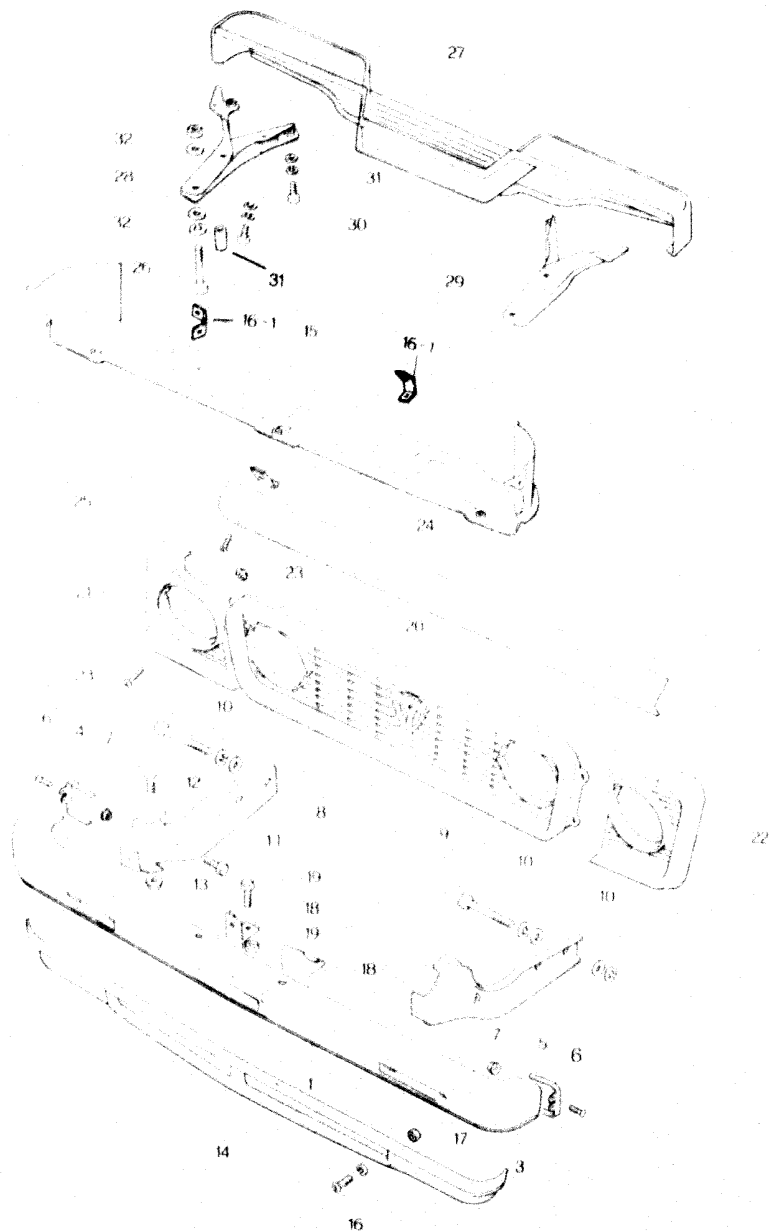

No.	Part Number	Description	Q'ty	Remarks
1	1854 50 031	Bumper (C), Front	1	
2	1854 50 060	Bumper (R), Front	1	
3	1854 50 070	Bumper (L), Front	1	
4	1854 50 062	Extension (R)	1	
5	1854 50 072	Extension (L)	1	
6	0223 50 275	Screw, Extension	4	
7	99940 0602	Nut, Extension	4	
8	1854 50 110A	Stay (R), Bumper	1	
9	1854 50 120A	Stay (L), Bumper	1	
10	99811 1245	Bolt, Stay - Body	4	
	99951 1226	Washer, Plain	4	
	99971 1200	Washer, Spring	4	
11	99786 0825	Bolt, Stay - Bumper	2	
	99952 1030	Washer, Plain	2	
12	0223 50 275	Screw, Bumper	12	
13	99940 0602	Nut, Bumper	12	
14	1854 50 091	Panel, Front Skirt	1	
15	1854 50 130A	Intake, Air	1	
16	99834 0512	Screw, Skirt Panel & Air Intake	13	
16-1	1854 50 165	Bracket, Air Intake	2	

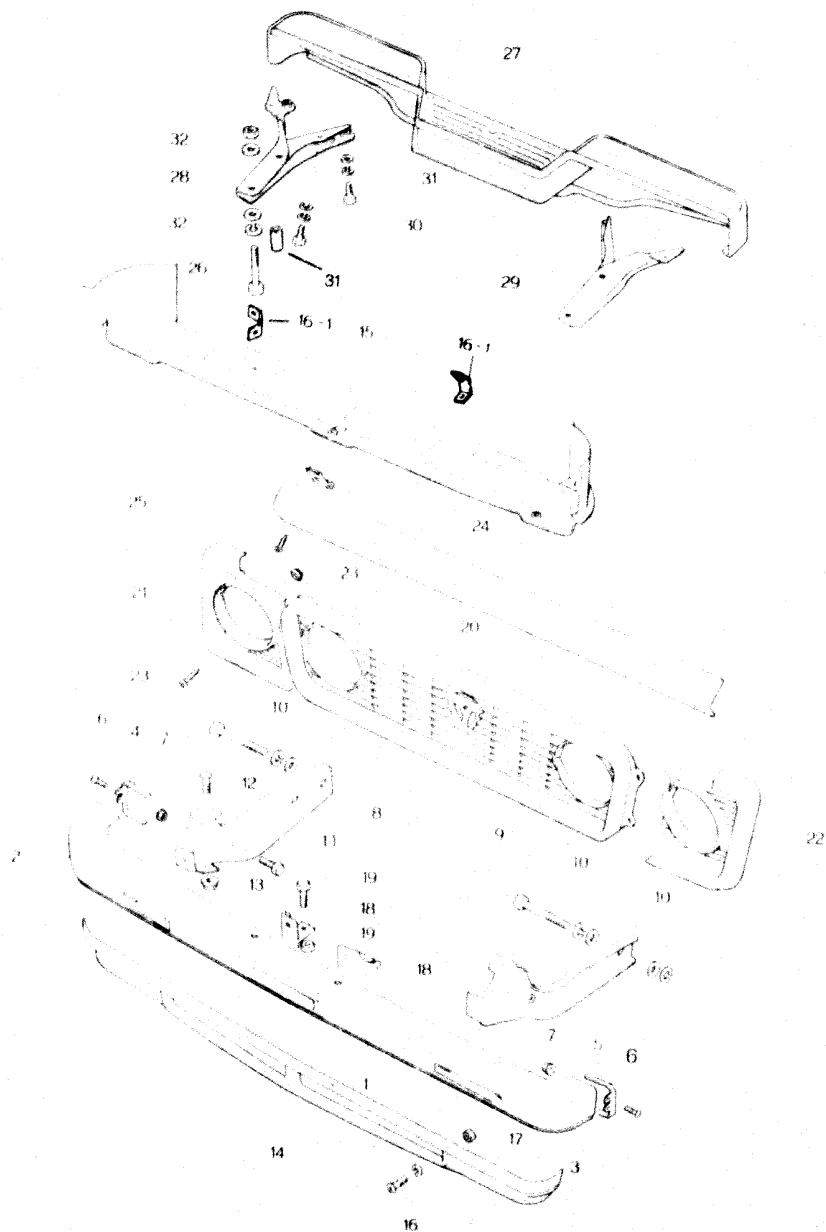

No.	Part Number	Description	Qty	Remarks
	99951 0618	Washer, Plain	13	
17	99940 0502	Nut, Skirt Panel & Air Intake	8	
18	1823 50 098	Holder, Number Plate	2	
19	99806 0616	Bolt, Number Plate Holder	2	
	99940 0602	Nut	2	
20	1854 50 511	Grille, Radiator	1	
21	1854 50 521	Bezel (R), Head Lamp (BLK)	1	
22	1854 50 531	Bezel (L), Head Lamp (BLK)	1	
23	99769 0425B	Screw, Grille & Bezel	12	
	99910 0403	Grommet, Screw	12	
24	1854 50 551	Garnish, Upper	1	
25	99769 0416	Screw, Garnish	4	
	99896 0400	Nut, Spring	4	
26	1854 78 615	Bolt, Rear Bumper	4	
	1823 78 620B	Bumper, Rear	1	
28	1854 78 640A	Stay (R), Rear Bumper	1	
29	1854 78 650A	Stay (L), Rear Bumper	1	
30	99781 1025	Bolt	6	
	99951 1022	Washer, Plain	6	
	99971 1000	Washer, Spring	6	
31	1855 78 616	Spacer	2	

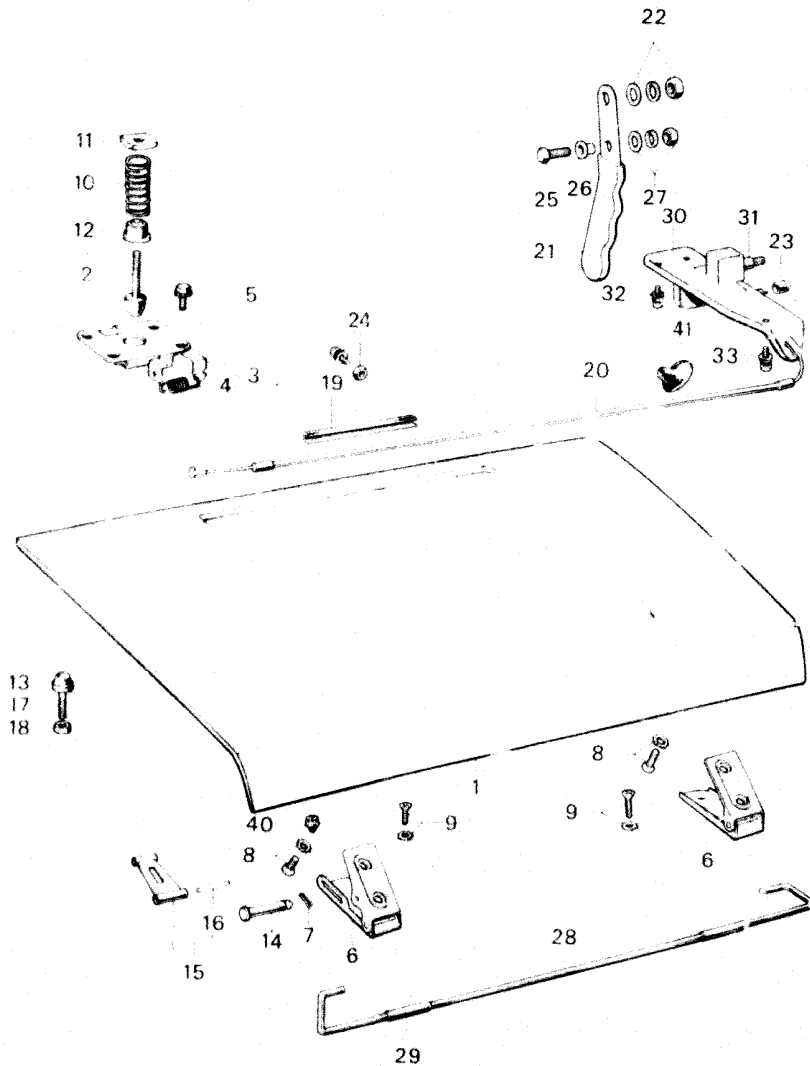

No.	Part Number	Description	Q'ty	Remarks
1	3790 52 010	Bonnet	1	
2	0187 52 141	Hook Bonnet	1	
3	0603 52 160B	Lock, Bonnet	1	
4	0305 52 331	Spring Return-Lock	1	
5	99796 0616	Bolt, Bonnet Lock	4	
	99953 0600	Washer, Plain	4	
	99971 0600	Washer, Spring	4	
6	0603 52 210B	Hinge (R), Bonnet	1	
	0603 52 260A	Hinge (L), Bonnet	1	
7	99221 1610	Pin, Split-Bonnet Hinge	1	
8	99831 0820	Screw, Hinge Upper	4	
	99975 0800	Washer, Toothed	4	
9	99837 0825	Screw, Hinge Lower	4	
	99975 0800	Washer, Toothed	4	
10	0603 52 142	Spring, Lift	1	
11	0603 52 143	Nut, Lock	1	
12	0187 52 144	Seat, Lower-Spring	1	

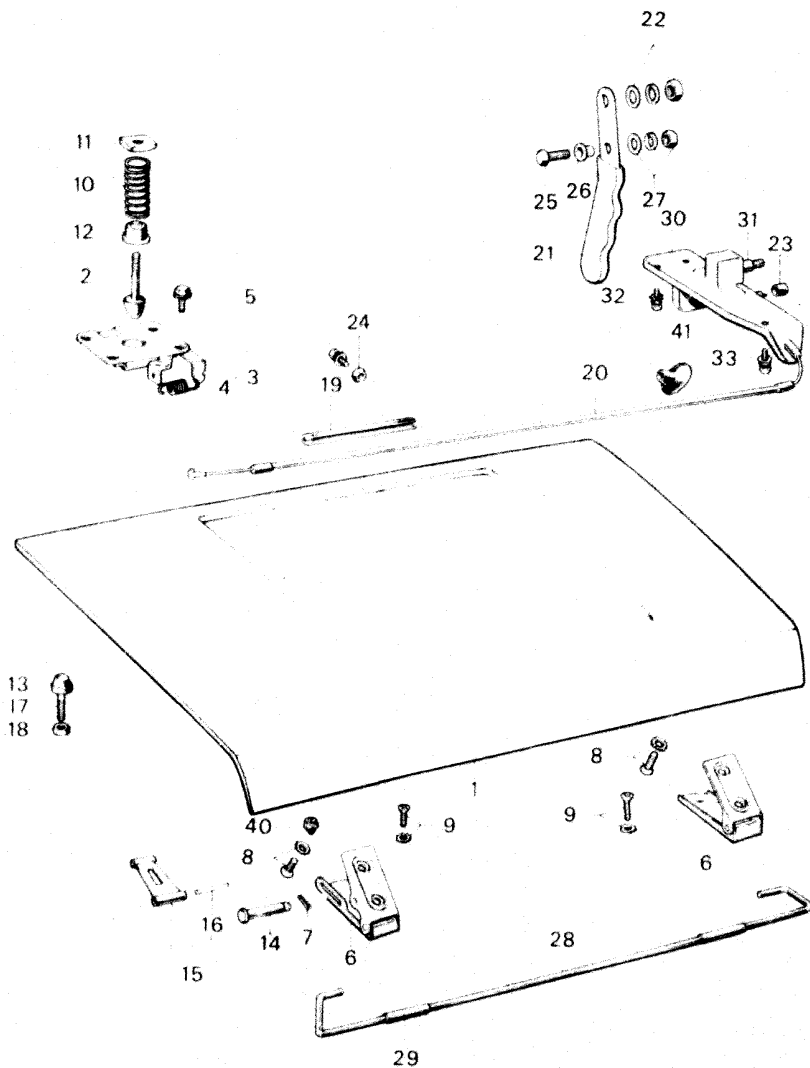

No.	Part Number	Description	Qty	Remarks
13	0603 52 451 A	Rubber. Cushion-Bonnet	2	
14	0603 52 214	Pin No 2. Stop	1	
15	0603 52 230	Plate. Stop	1	
16	0603 52 232A	Pin No 1. Stop	1	
17	99831 0830	Screw. Cushion Rubber	2	
18	99902 0800	Nut. Cushion Rubber	2	
19	0603 52 472	Rubber. Seal-Bonnet	1	
20	0603 52 510	Wire. Release-Bonnet	1	
21	0208 52 520	Handle. Release Wire	1	
22	99906 0600	Nut. Release Handle	1	
	99952 0600	Washer. Plain	1	
	99972 0800	Washer. Wave	1	
23	0187 52 523	Rubber. Stopper-Release Handle	1	
24	99797 0516	Bolt. Release Wire	1	
	99952 0500	Washer. Plain	1	
	99971 0500	Washer. Spring	1	
	99906 0500	Nut	1	
25	0187 52 531	Bolt. Release Wire Handle	1	

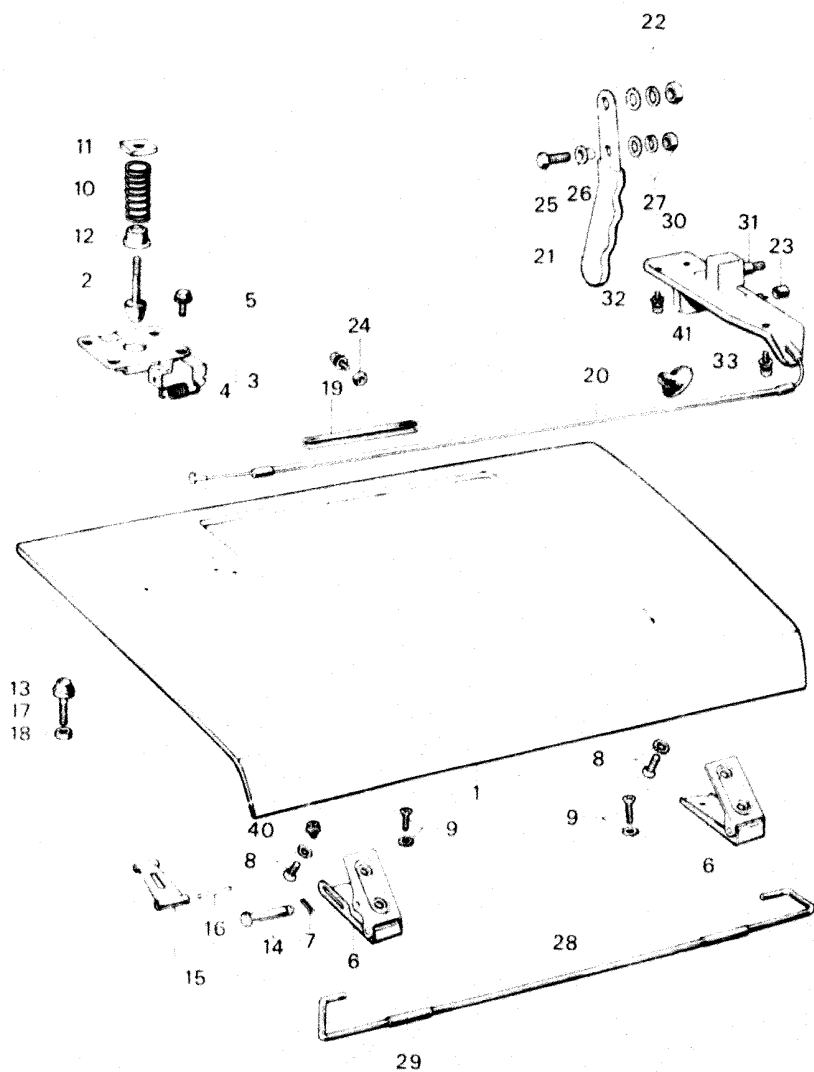

No.	Part Number	Description	Qty	Remarks
26	0187 52 532	Spacer Release Wire Stop	1	
27	99906 0600	Nut Release Wire Handle	1	
	99952 0600	Washer Plain	1	
	99971 0600	Washer Spring	1	
28	0603 52 351A	Bar Torsion	1	
29	0603 52 353	Support Torsion Bar	2	
30	2677 52 540A	Bracket Release Handle	1	
31	0603 52 543	Pin Handle Set	1	
32	99834 0512	Screw Release Handle Bracket	2	
	99975 0500	Washer Toothed	2	
33	99830 0512	Screw Release Handle Bracket	1	
	99953 0500	Washer Plain	1	
	99971 0500	Washer Spring	1	
34	1854 52 811	Rubber Seal	1	
35	1854 52 812	Plate "A" Rubber Set	1	
36	1854 52 813C	Plate "B" Rubber Set (Rotary)	1	
37	1854 52 814B	Plate "C" Rubber Set	1	
38	1854 52 815C	Rubber No. 2 Seal	2	

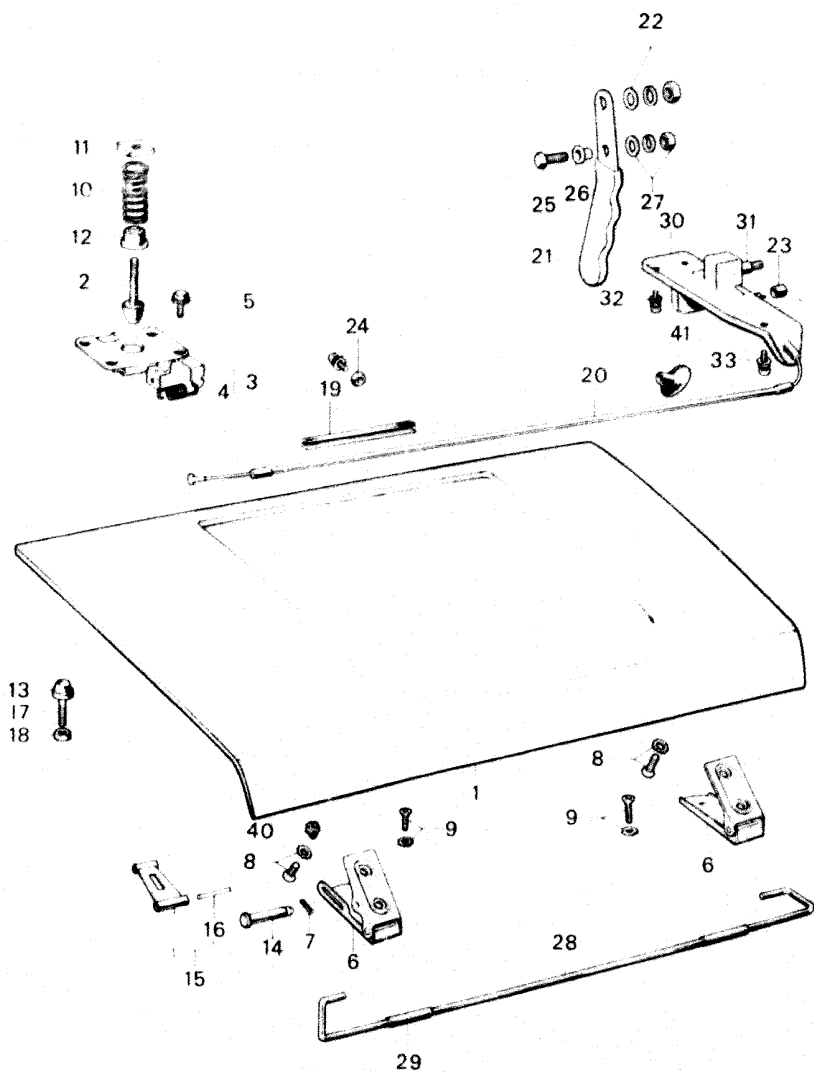

No.	Part Number	Description	Q'ty	Remarks
39	99865 0510	Screw, Tapping	11	
40	0118 58 931	Rubber, Stop-Bonnet Hinge	1	
41	2677 52 505	Protector, Bonnet Release Wire (Recipro)	1	
	0118 70 531	Protector, Bonnet Release Wire	1	
42	0866 52 388A	Pad, Bonnet (1800 cc)	1	

BODY PANELS (FRONT)

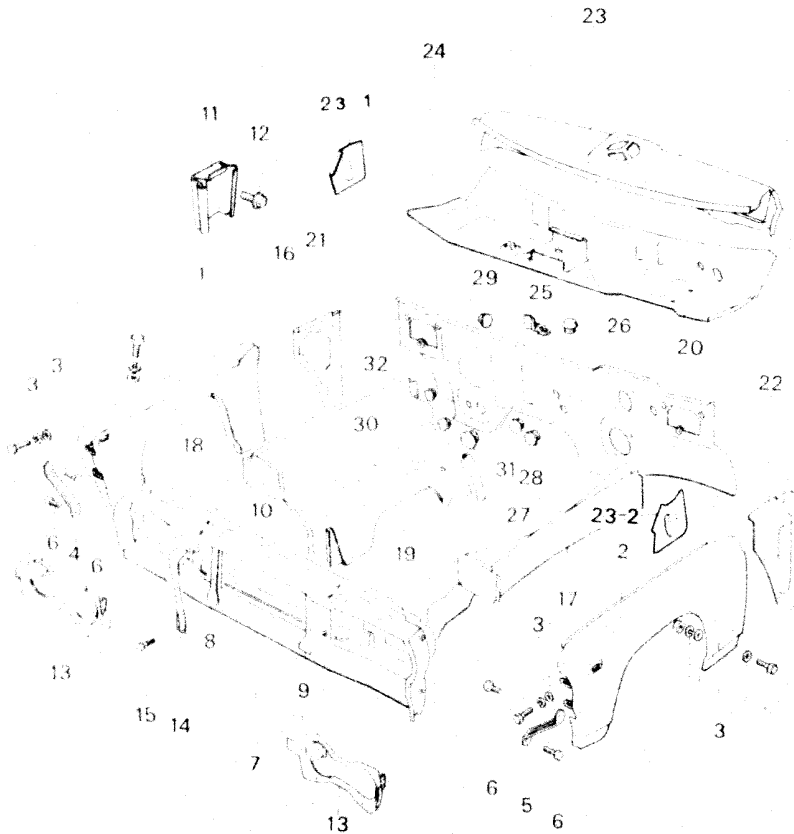

BODY PANELS (FRONT)

No.	Part Number	Description	Q'ty	Remarks
1	1854 51 020B	Panel (R), Fender	1	
2	1854 51 520B	Panel (L), Fender	1	
3	99806 0614	Bolt, Fender Panel	20	
	99953 0600	Washer, Plain	20	
	99971 0600	Washer, Spring	20	
	99940 0602	Nut	2	
4	1823 51 050	Plate (R), Junction	1	
5	1823 51 550	Plate (L), Junction	1	
6	99786 0610	Bolt, Junction	4	
7	3790 53 030	Panel, Shroud-Radiator	1	
8	1854 53 050A	Member (R), Radiator	1	
9	1854 54 050A	Member (L), Radiator	1	
10	1854 53 036	Member No. 2, Cross	1	
11	0483 53 241	Bracket, Reserve Tank	1	
12	99796 0612	Bolt, Reserve Tank Bracket	2	
13	1854 53 070	Bracker, Head Lamp	2	
14	1854 53 091B	Member, Grille Set	2	
15	99796 0612	Bolt, Grille Set Member	8	
16	3790 53 110	Panel (R), Tire Apron-Front	1	
17	3790 54 110	Panel (L), Tire Apron-Front	1	

51 ~ 56 BODY PANELS (FRONT)

51 ~ 56 BODY PANELS (FRONT)

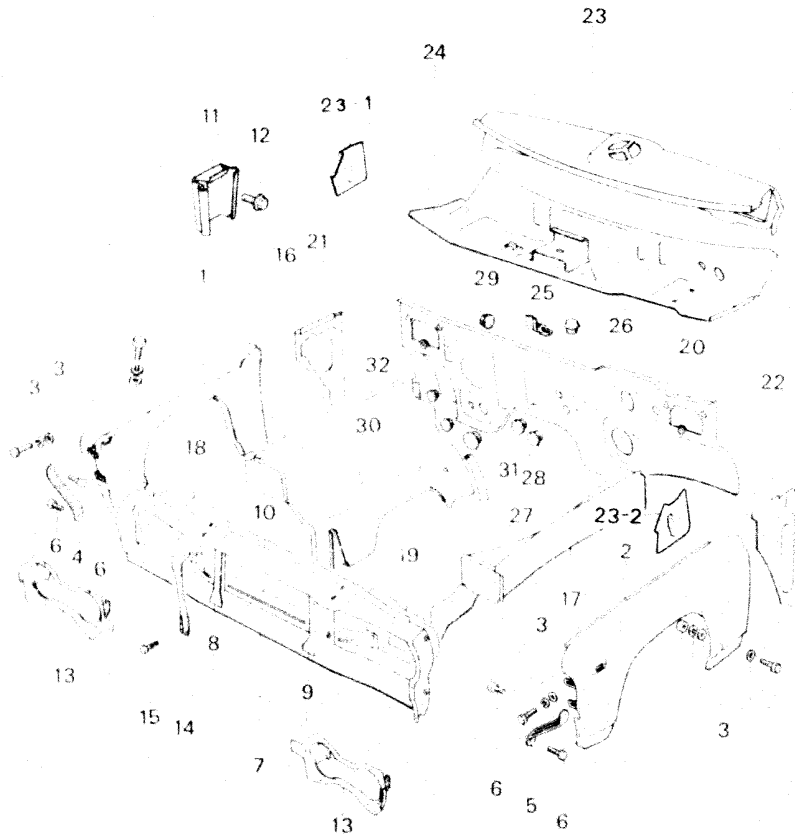

No.	Part Number	Description	Q'ty	Remarks
18	1854 53 160B	Panel (R), Shroud	1	
19	1854 54 160C	Panel (L), Shroud	1	
20	1854 53 200	Panel, Dash-Lower	1	
21	2541 53 220A	Panel (R), Cowl Side	1	
22	3792 54 220	Panel (L), Cowl Side	1	
23	1854 53 230C	Panel, Instrument	1	
• 23	1854 53 230D	Panel, Instrument	1	77/12 ~ X
23-1	1854 53 181	Bracket, Dash panel (R)	1	
23-2	1854 54 181	Bracket, Dash panel (L)	1	
24	3790 53 380	Panel, Dash-Upper	1	
25	1823 53 410A	Bracket, Tuner Set	1	
26	0187 53 134	Rubber, Dust Seal	1	
27	99336 08038	Pipe, Drain	2	
28	0208 56 615	Plug, Drain (W/O Heater)	2	
29	0613 63 105A	Cover, Service Hole	1	
30	0187 53 134	Rubber, Dust Seal	1	} (W/O Cooler)
31	1708 61 031	Plug, Hole	1	
32	1004 72 873	Grommet	2	

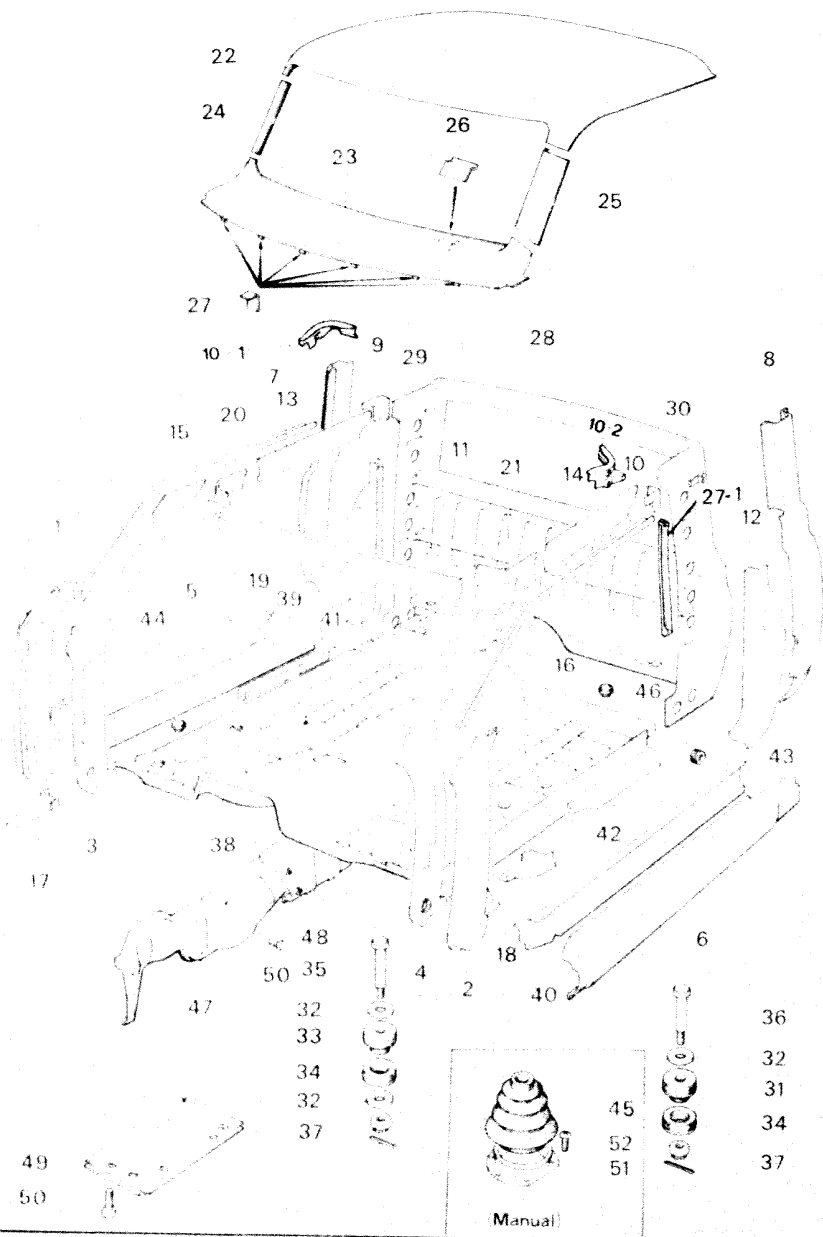

No.	Part Number	Description	Qty	Remarks
1	3792 53 510	Pillar (R), Front-Lower	1	
2	3792 54 510	Pillar (L), Front-Lower	1	
3	0603 53 520A	Pillar (R), Front-Inside	1	
4	0603 54 520A	Pillar (L), Front-Inside	1	
5	0603 53 531	Pillar (R), Side Sill-Outer	1	
6	0603 54 531	Pillar (L), Side Sill-Outer	1	
7	3792 53 551C	Pillar (R), Rear-Outer	1	
8	3792 54 551C	Pillar (L), Rear-Outer	1	
9	0603 53 552	Plate (R), Rear Pillar Corner	1	
10	0603 54 552	Plate (L), Rear Pillar Corner	1	
10-1	3790 53 591	Junction, Rear Corner (R)	1	
10-2	3790 54 590	Junction, Rear Corner (L)	1	
11	2540 53 560A	Pillar (R), Rear-Front Side	1	
12	2540 54 560A	Pillar (L), Rear-Front Side	1	
13	3792 53 571	Member (R), Roof Side	1	
14	3792 54 571	Member (L), Roof Side	1	
15	3792 53 572	Rail (R), Rain	1	
16	3792 54 572	Rail (L), Rain	1	
17	0603 53 573	Plate (R), Cowl Set	1	
18	0603 54 573	Plate (L), Cowl Set	1	

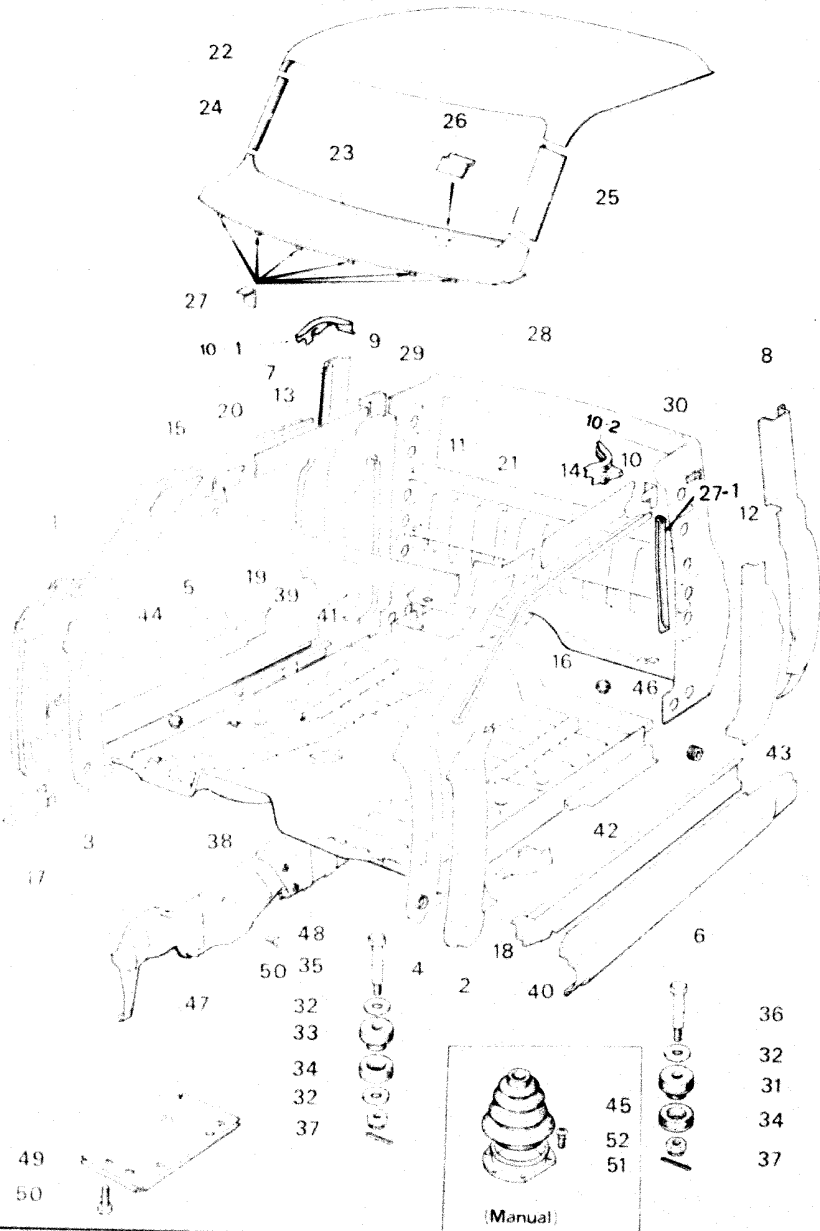

No.	Part Number	Description	Q'ty	Remarks
19	3792 53 600	Member, Roof Cross	1	
20	0603 53 611	Plate (R), Junction	1	
21	0603 54 611	Plate (L), Junction	1	
22	3792 53 681A	Panel, Roof	1	
23	2651 53 682A	Panel, Cowl	1	
24	0603 53 683A	Pillar (R), Front	1	
25	0603 53 684A	Pillar (L), Front	1	
26	0578 53 685	Stopper, Cowl Panel	1	
27	0221 53 916	Clip	6	
27-1	3792 53 581	Rain, Rail (R)	1	
	3792 54 581	Rain, Rail (L)	1	
28	3790 53 700	Plate, Back	1	
•	3790 53 700A	Plate, Back	1	77/5 ~ Δ
29	3790 53 710A	Pillar (R), Rear Inner	1	
30	3792 54 710A	Pillar (L), Rear Inner	1	
31	0603 53 950A	Rubber, Mounting Lower	2	
32	99951 1030	Washer, Plain-Mounting Rubber	6	
33	0603 53 950A	Rubber No. 3, Mounting Upper	4	
34	0603 53 970	Rubber, Mounting Lower	6	
35	0603 53 984A	Bolt, Mounting	4	

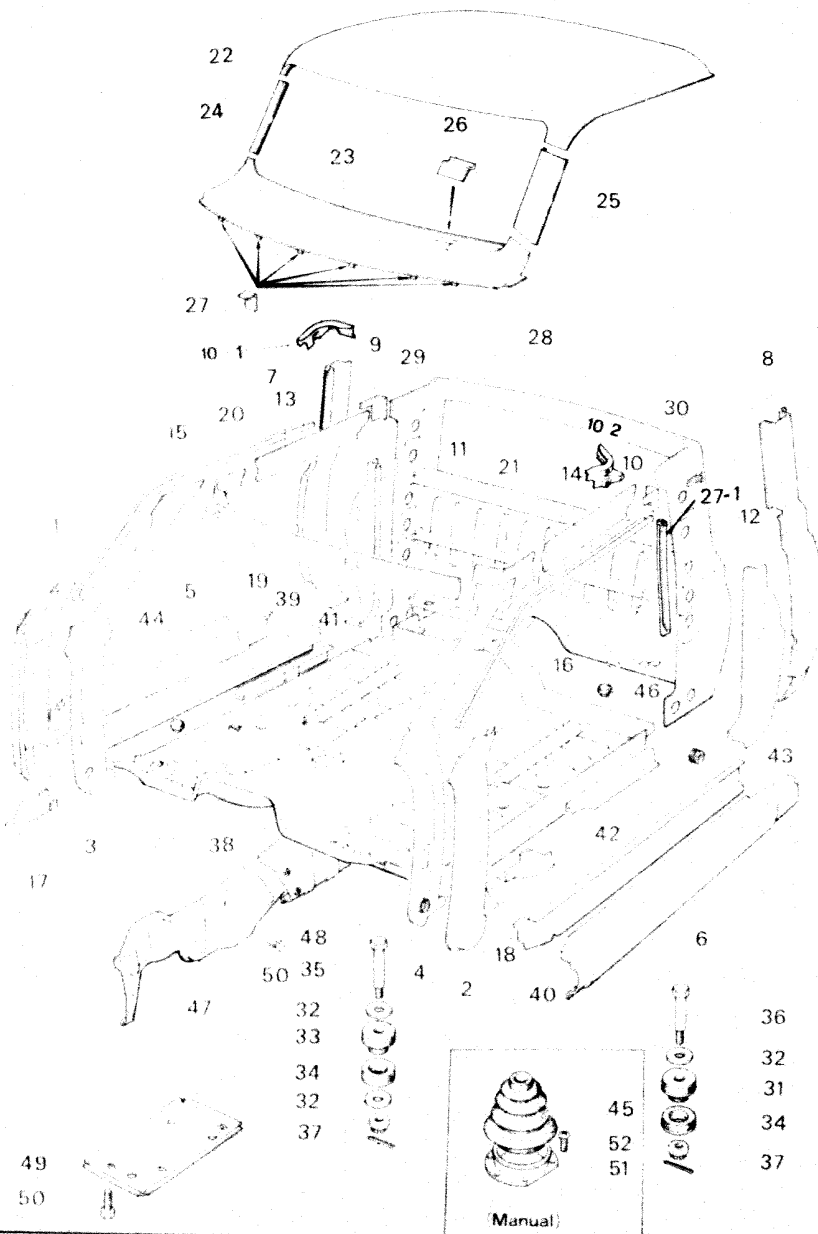

No.	Part Number	Description	Q'ty	Remarks
36	0603 53 984A	Bolt Mounting	2	
37	99903 0800	Nut, Grooved	6	
	99221 2015	Pin, Split	6	
38	3790 56 010	Board, Floor	1	
●	3790 56 010A	Board, Floor	1	77/5 ~ Δ
39	3875 56 031	Panel (R), Side Sill-Inner	1	
●	3875 56 031A	Panel (R), Side Sill-Inner	1	77/9 ~ Δ
40	3875 56 531	Panel (R), Side Sill-Inner	1	
●	3875 56 531A	Panel (R), Side Sill-Inner	1	77/9 ~ Δ
41	3792 56 200	Bracket (R), Seat	1	
42	3792 56 700	Bracket (L), Seat	1	
43	0111 41 692	Protector, Cord	4	
44	0118 56 241	Plug, Drain	10	
45	0247 56 274A	Boot, Change Lever (Manual)	1	
46	0208 56 615	Plug, Drain	6	
47	1854 56 811	Insulator, Heat	1	
48	1854 56 840C	Insulator No. 2, Heat	1	
49	1854 56 851A	Insulator No. 3, Heat	1	
50	99796 0610	Bolt, Heat Insulator	7	
	99796 0612	Bolt, Heat Insulator	4	
	99952 0618	Washer, Plain	11	

53 ~ **56** **BODY PANELS (FLOOR & ROOF)**

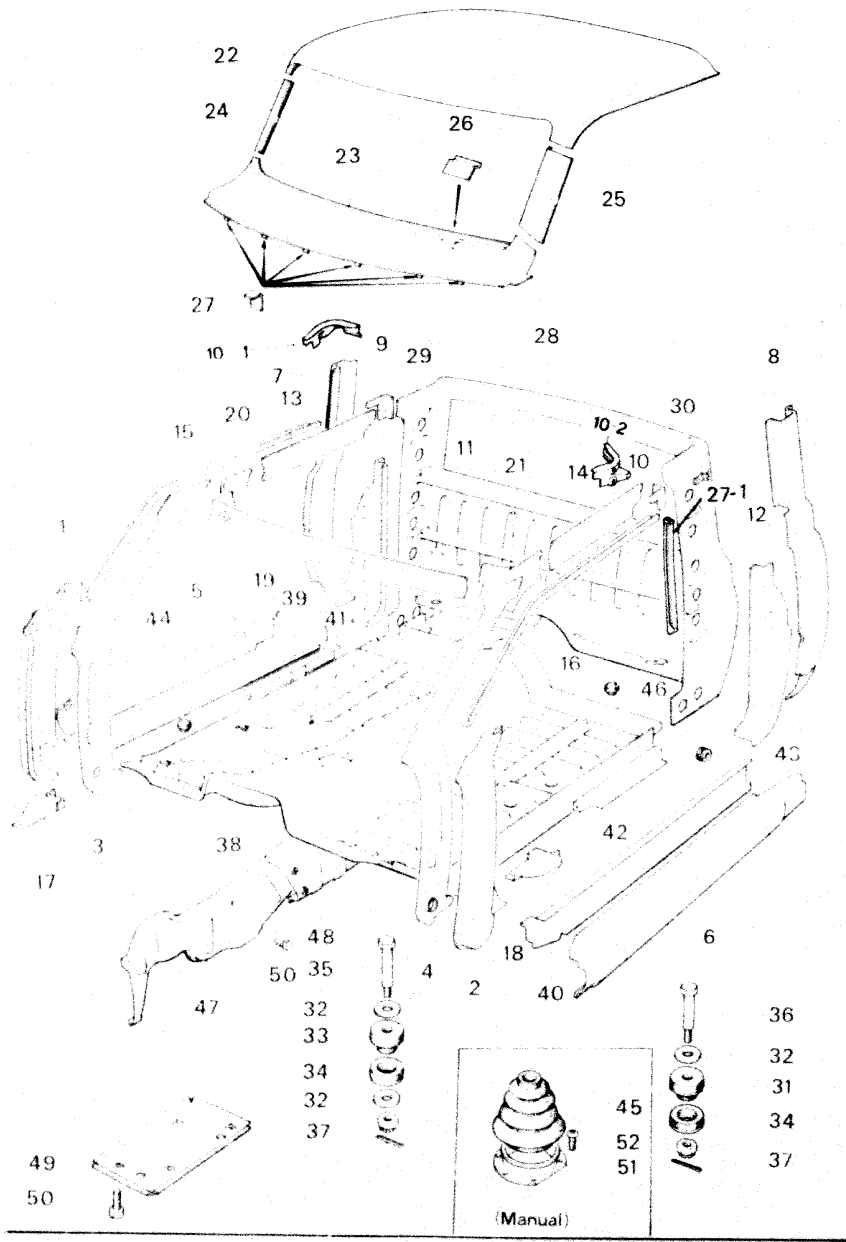

3-H2

53 ~ **56** **BODY PANELS (FLOOR & ROOF)**

No.	Part Number	Description	Qty	Remarks
51	1002 64 491	Seat, Boot	1	(Manual)
52	99865 0512	Screw, Boot Seat		
			6	

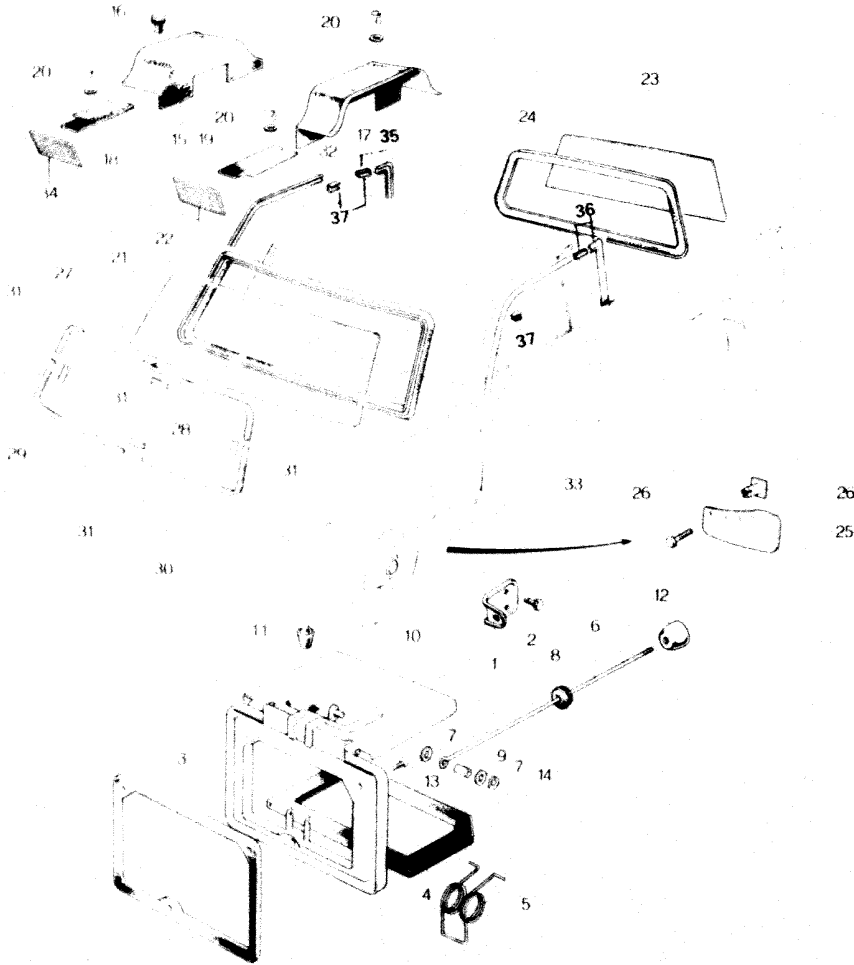

No.	Part Number	Description	Qty	Remarks
1	1854 54 234	Holder, Rod (R), Side	1	
2	99830 0612	Bolt, Rod Holder	2	
3	0603 53 431D	Gasket, Ventilator	2	
4	0603 53 432A	Rubber, Seal	2	
5	0603 53 433A	Spring, Ventilator	2	
6	0603 53 434B	Rod (R), Ventilator	1	
	0617 54 434	Rod (L), Ventilator	1	
•	0603 53 434B	Rod (L), Ventilator	1	
7	0603 53 435	Washer, Rod	4	
8	0603 53 436	Grommet, Rod	2	
9	0603 53 438	Bush, Ventilator Rod	2	
10	0603 53 440B	Ventilator	2	
11	0208 70 713	Rubber, Stopper-Ventilator	2	
12	0118 70 722A	Knob, Ventilator Rod	2	
13	99833 0512	Screw, Ventilator	6	
14	99576 0400	Ring, Stop-Rod	2	
15	2677 53 811A	Cover (R), Dust	1	
16	99786 0512	Screw, Dust Cover	3	
17	0603 53 811B	Cover (L), Dust	1	
18	0603 53 821	Cover No. 2 (R), Dust	1	

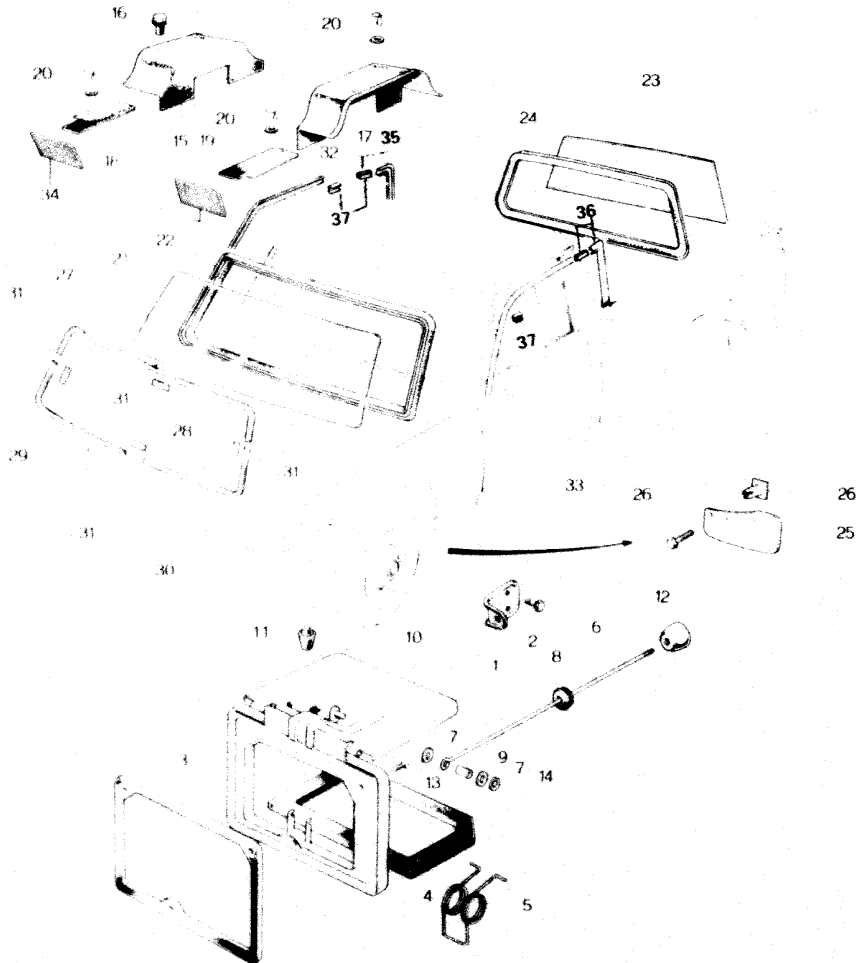

No.	Part Number	Description	Q'ty	Remarks
19	2677 54 821	Cover No. 2 (L.), Dust	1	
20	0193 53 462	Fastener, Dust Cover	8	
	99953 0600	Washer, Plain	8	
21	1823 53 901	Glass, Front Window (Blue Pane)	1	
•	1823 53 901A	Glass, Front Window (Blue Pane)	1	Selective use 77/2 ~ Δ (France) 77/2 ~ ○ (Except France)
	2651 53 901A	Glass, Front Window (Transparent)	1	
•	2651 53 901B	Glass, Front Window (Transparent)	1	77/2 ~ Δ
22	0603 53 902	Weatherstrip, Front Window Glass (W/O Mould)	1	Selective use
	2541 53 902	Weatherstrip, Front Window Glass (With Mould)	1	
23	3760 53 941	Glass, Back Window (Blue Pane)	1	
•	3760 53 941A	Glass, Back Window	1	77/2 ~ Δ (France) 77/2 ~ ○ (Except France)
	3764 53 941	Glass, Back Window (Transparent)	1	
•	3764 53 941A	Glass, Back Window (Transparent)	1	77/2 ~ Δ
24	3792 53 912	Weatherstrip, Back Window Glass	1	
25	1854 53 891A	Flap, Front	2	
26	99769 0616B	Bolt, Front Flap	8	
	99910 0601	Grommet, Screw	8	
27	2541 53 991	Mould (R), Upper-Front Window	1	
28	2541 54 991	Mould (L), Upper-Front Window	1	

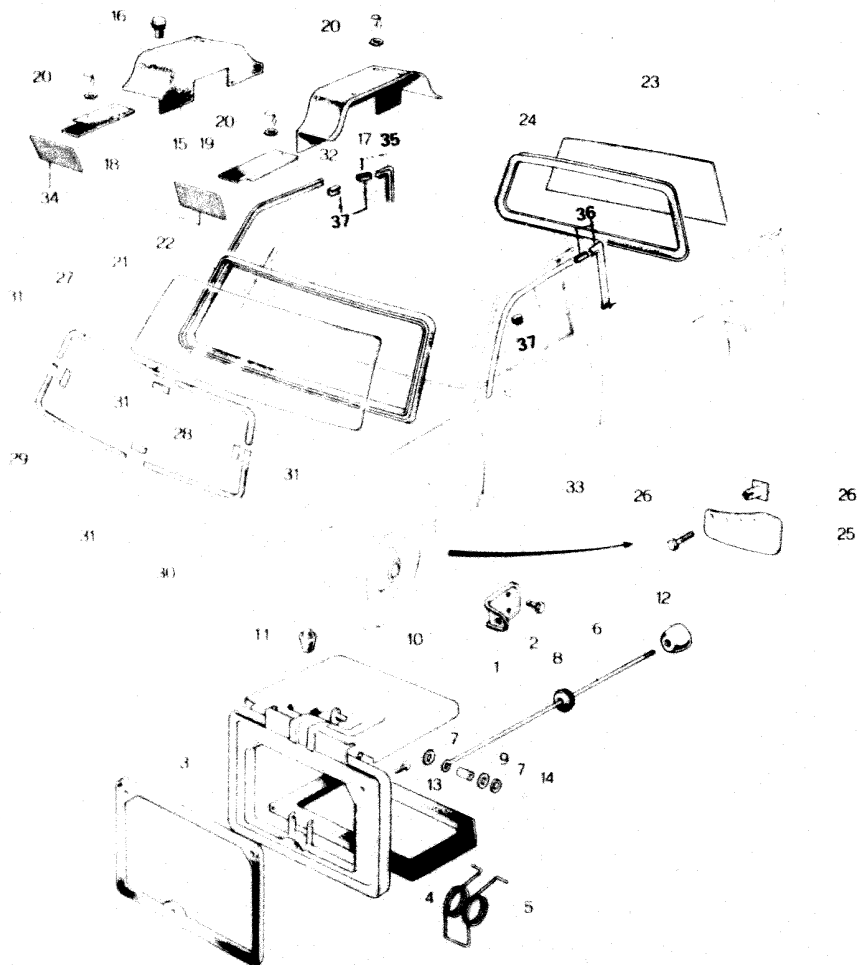

No.	Part Number	Description	Q'ty	Remarks
29	2541 53 992	Mould (R), Lower-Front Window	1	(With Mould)
30	2541 54 992	Mould (L), Lower-Front Window	1	
31	0735 70 425A	Junction, Front Window Mould	4	
32	3792 99 731	Mould Set (R), Drip Front	1	
33	3792 99 736	Mould Set (L), Drip Front	1	
34	0208 58 925	Screen, Side Seal	2	
35	3792 99 732	Mould Set (R), Drip Rear	1	
36	3792 99 737	Mould Set (L), Drip Rear	1	
37	0223 70 827	Clip, Drip Moulding	16	

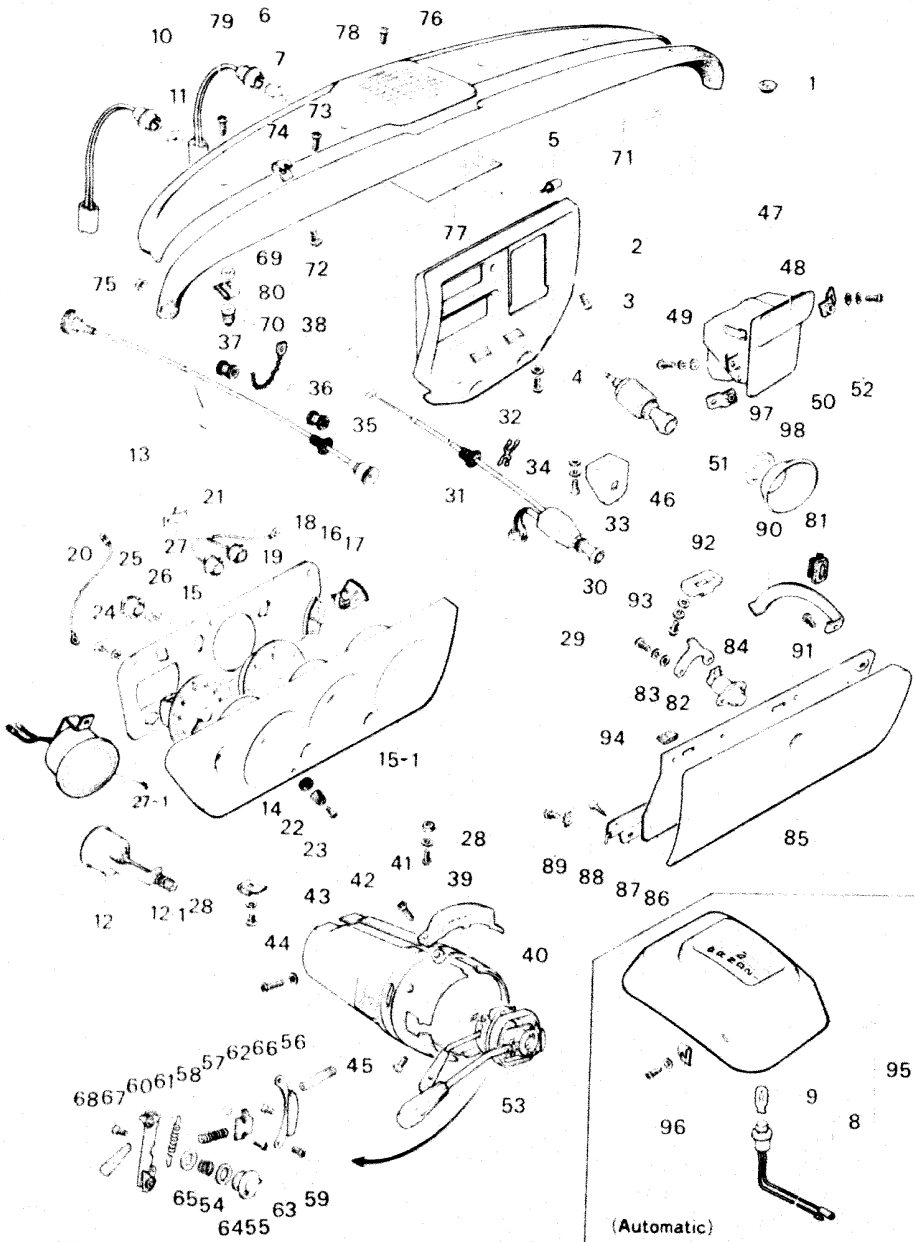

No.	Part Number	Description	Qty	Remarks
1	0613 53 105A	Cover, Service Hole	2	
2	1854 55 220	Panel, Center	1	
3	99862 0516B	Screw, Center Panel	2	
4	99860 0512	Screw, Center Panel	1	
	99952 0500	Washer, Plain	1	
5	99896 0500	Nut, Spring	3	
6	1011 55 240	Bulb & Socket	1	
7	99701 1030	Bulb	1	
8	1840 55 240	Bulb & Socket Indicator	1	(Automatic)
9	99701 6030	Bulb	1	
10	1011 55 280	Lamp	1	
11	99701 6030	Bulb	1	
12	1854 55 490	Resistor	1	
12-1	1011 60 241A	Knob, Resistor	1	
13	3787 55 430	Meter Set (Manual)	1	
	3790 55 430	Meter Set (Automatic)	1	

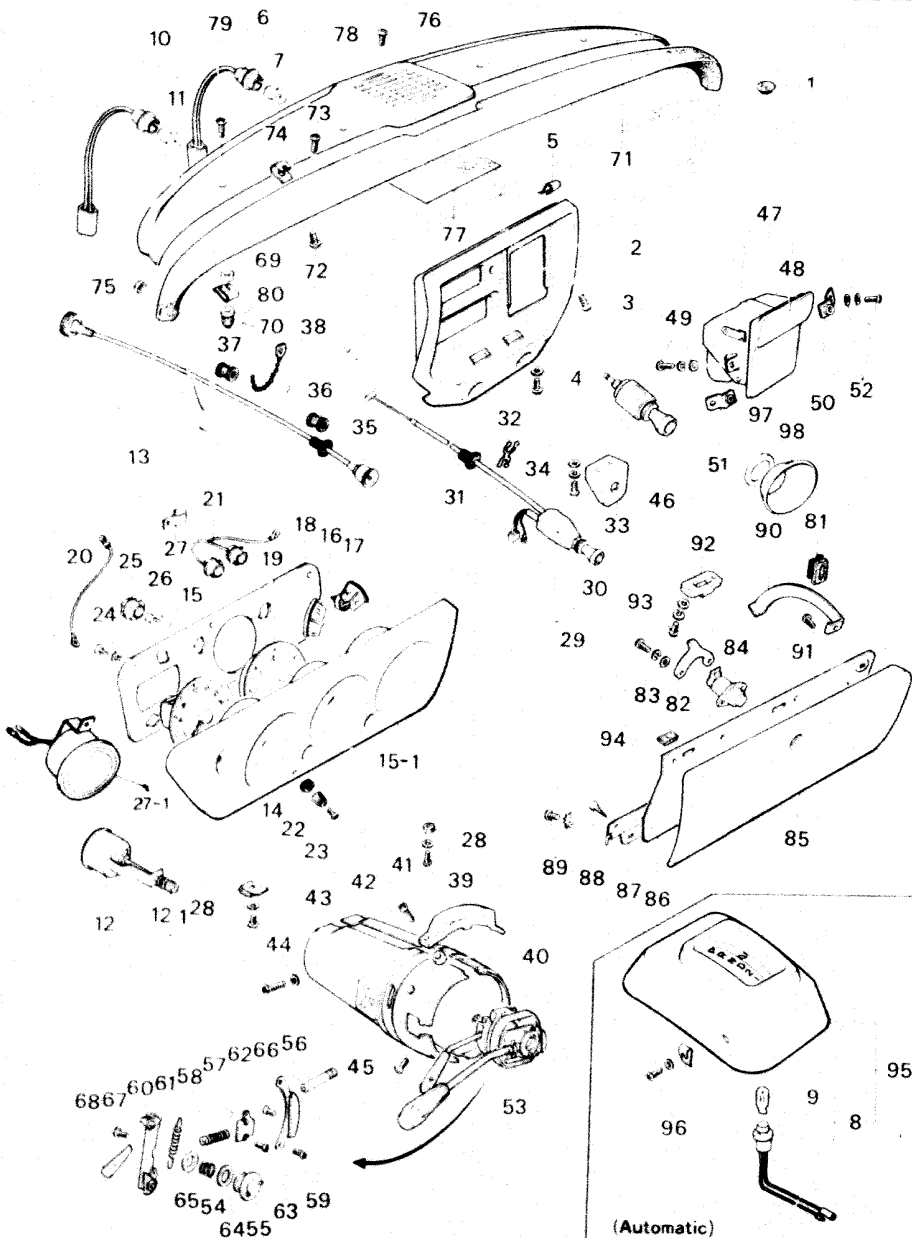

No.	Part Number	Description	Qty	Remarks
14	0326 75 011	Grommet	1	
15	3790 75 021	Speedometer	1	
15-1	3775 75 010 A	Hood Meter	1	
16	0483 75 022	Meter, Fuel	1	
17	0317 75 023	Meter, Temp.	1	
18	3900 75 025 A	Plate, Bottom	1	
19	3787 75 026	Tachometer (Manual)	1	
	3790 75 026	Tachometer (Automatic)	1	
20	3900 75 030 A	Cord	1	
21	0492 75 060	Harness, Wiring	1	
22	0824 75 149	Knob, Trip Meter	1	
23	0824 75 150	Screw, Knob	1	
24	0710 75 436	Screw, Tapping	5	
25	0259 55 261	Socket	10	
26	99701 6030	Bulb	12	
27	3900 75 035	Clip	2	
27-1	1568 75 029	Buzzer (Manual)	1	
28	99864 0520 B	Screw, Meter	4	
	99952 0500 B	Washer, Plain	4	
	0820 56 905	Washer, Spring	2	

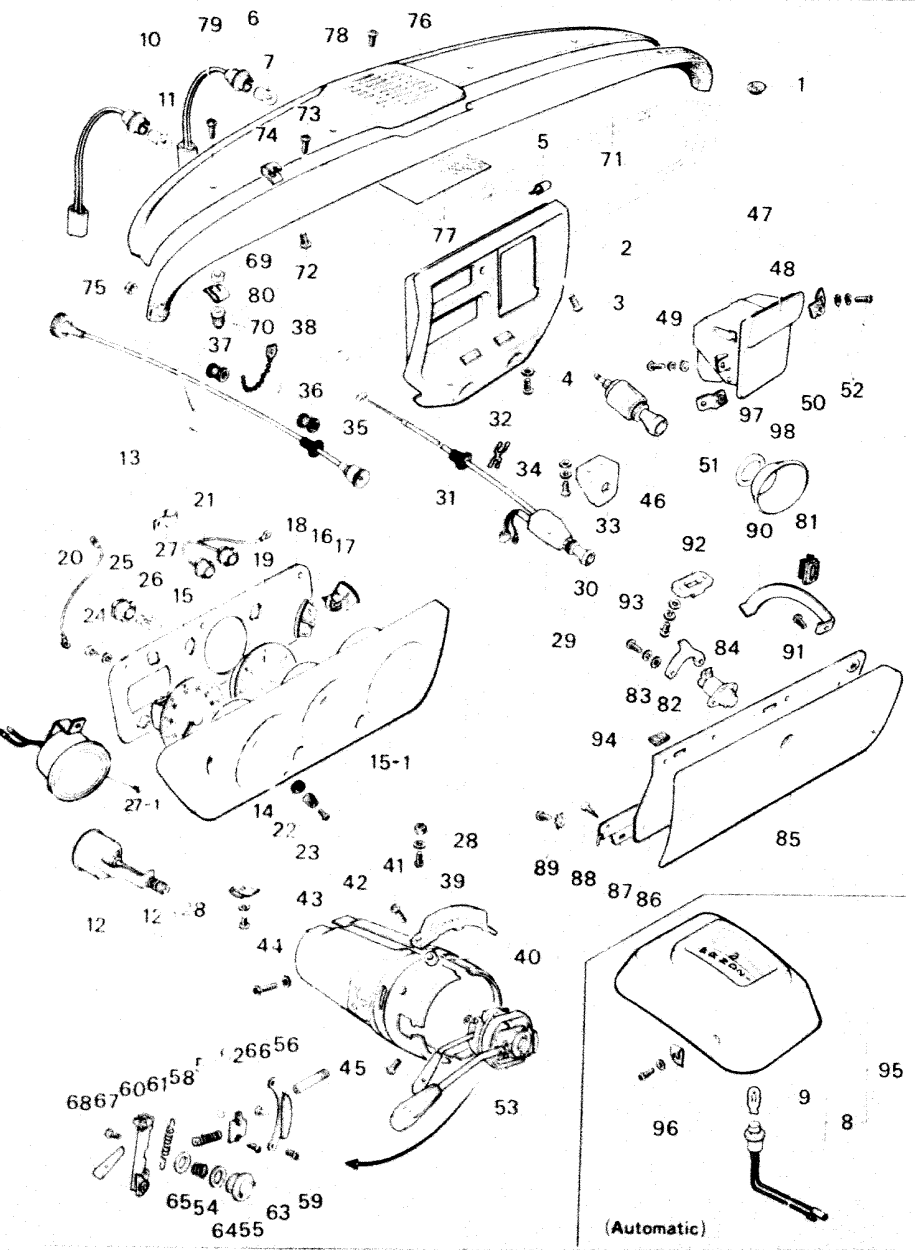

No.	Part Number	Description	Q'ty	Remarks
	99896 0500	Nut. Spring	2	
29	3787 60 050	Wire. Choke	1	
30	3597 60 053	Knob. Choke Wire	1	
31	0259 52 301	Grommet. Choke Wire	1	
32	99288 0808	Clip. Choke Wire	1	
33	1854 55 161	Bracket. Choke Wire	1	
34	99830 0510	Screw. Bracket	2	
35	1011 60 070 A	Cable. Speedometer	1	
36	99682 0801	Grommet. Speedometer Cable	1	
37	99686 0800	Grommet. Speedometer Cable	3	
38	99709 0108	Band. Speedometer Cable	1	
39	1907 60 311	Plate. Name. Column Cover	1	
40	1611 60 312	Spacer. Name Plate	2	
41	99832 0414 B	Screw. Name Plate	2	
42	1854 60 331 A	Cover (R.) Column (BLK)	1	
43	1854 60 341 A	Cover (L.) Column (BLK)	1	
44	99833 0412 B	Screw. Column Cover	1	
	99971 0400 B	Washer. Spring	1	

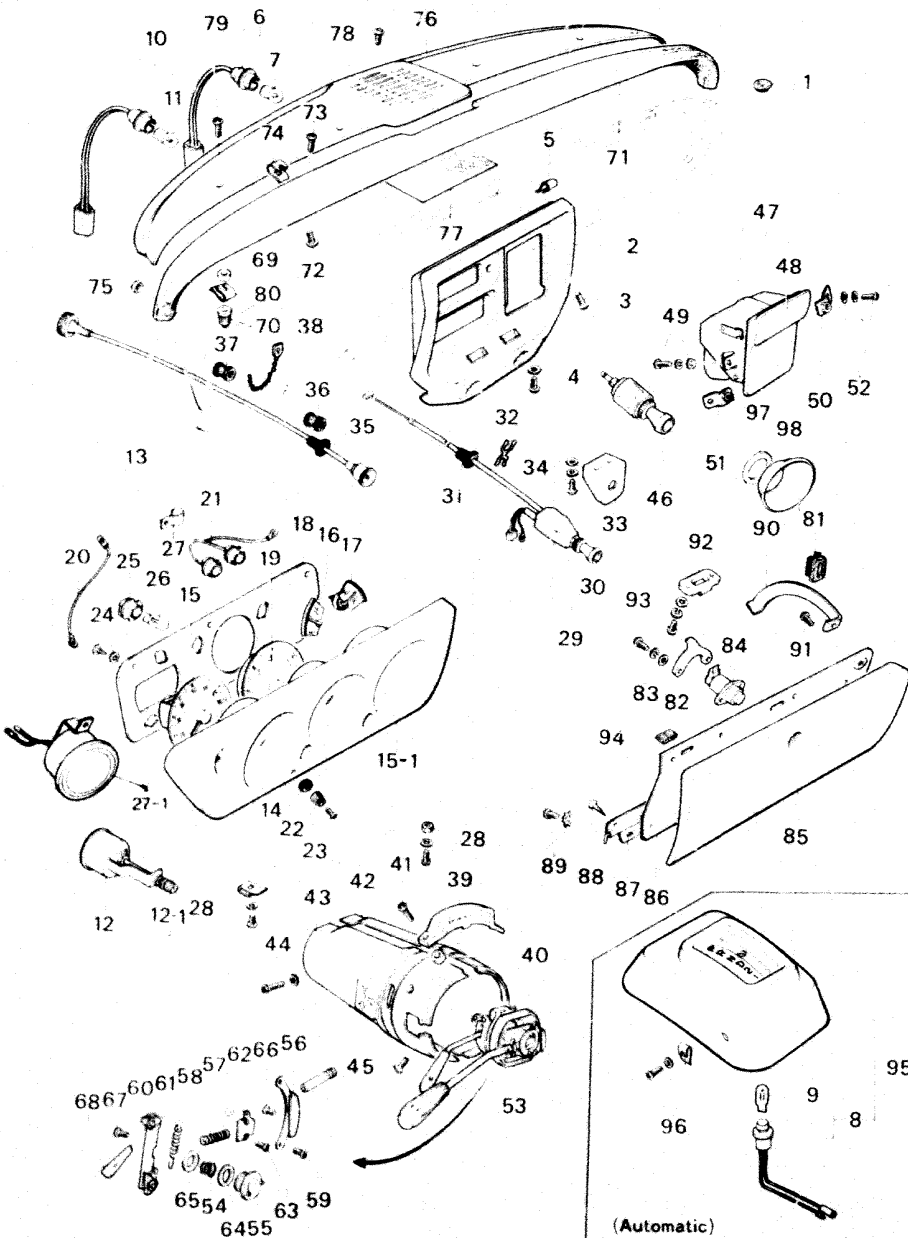

No.	Part Number	Description	Qty	Remarks
45	99832 0412B	Screw, Column Cover	2	
46	0866 60 720 A00	Lighter, Cigar (BLK)	1	
47	1854 64 620 A	Tray, Ash	1	
48	1854 64 640 A	Case, Inner	1	
49	99830 0508	Screw, Ash Tray	2	
50	1854 64 650	Bracket, Ash Tray	1	
51	1854 64 660	Bracket, Ash Tray	1	
52	99830 0508	Screw, Bracket	2	
53	3790 66 120	Switch, Combination	1	
54	0317 60 252	Spring, Cancel Cam	1	
55	0317 60 253	Cam, Cancel	1	
56	1634 60 254	Bracket, Fixing	1	
57	0317 60 255	Ball, Steel	1	
58	0317 60 256	Spring, Arm Set	1	
59	0317 60 257	Screw, Bracket	2	
60	0317 60 258	Arm	1	
61	0317 60 259	Spring, Ratchet	1	

DASHBOARD

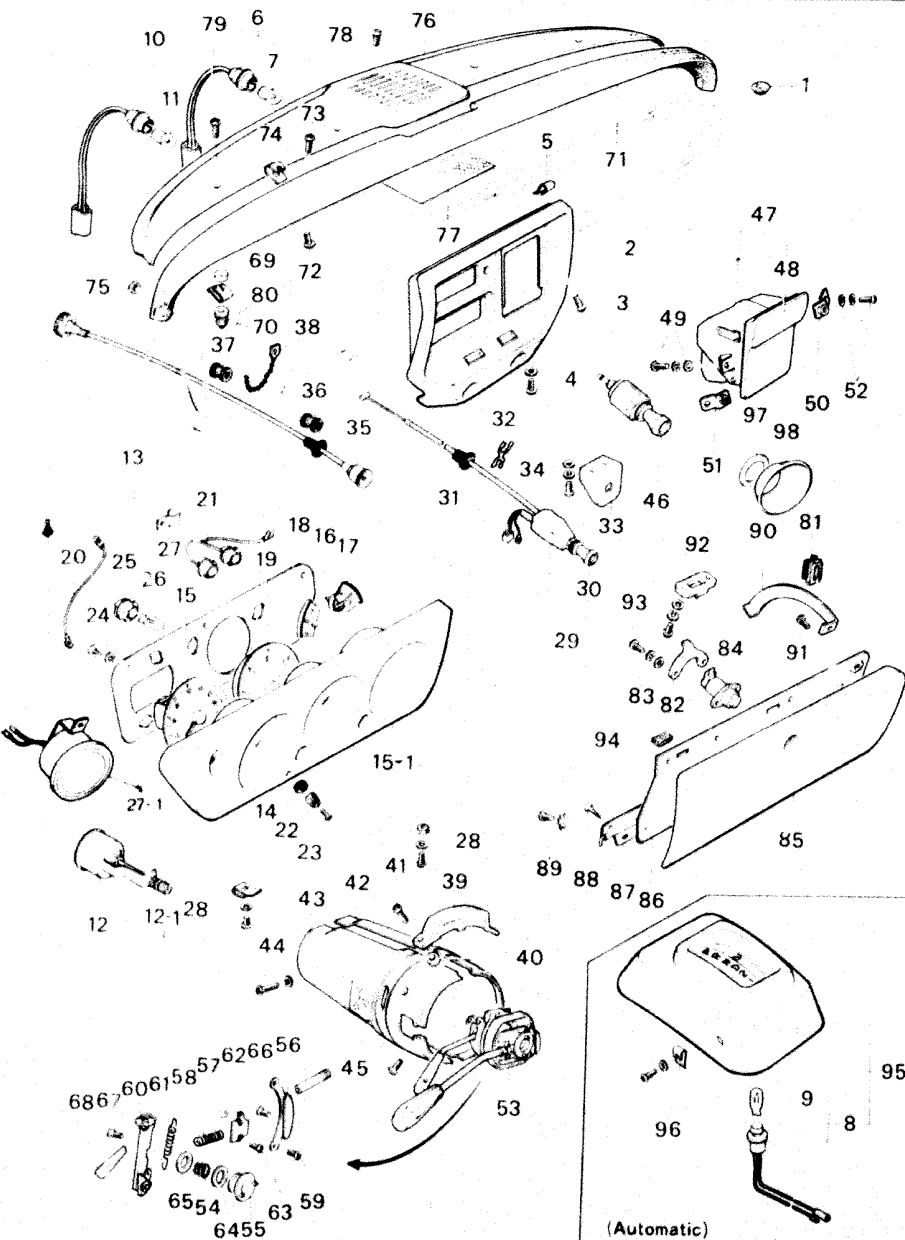

(Automatic)

DASHBOARD

No.	Part Number	Description	Q'ty	Remarks
81	0603 53 305	Guide, Glove Box	1	
82	2280 55 182	Guide, Glove Box	1	
83	99833 0416	Screw, Guide	2	
	99952 0400	Washer, Plain	2	
	99971 0400	Washer, Spring	2	
84	0274 55 200	Lock, Glove Box	1	
85	1879 70 220 A	Lid, Outer - Glove Box	1	
86	2370 70 231 A	Lid, Inner - Glove Box	1	
87	1854 70 240	Hinge, Glove Box	1	
88	99862 0410 B	Screw, Glove Box Lid & Hinge	9	
89	99834 0410 B	Screw, Hinge - Body	3	
	99973 0400	Washer, Toothed	3	
90	2370 70 261	Stopper, Glove Box Lid	1	
91	99832 0408 B	Screw, Stopper	1	
92	0317 70 262 A	Striker, Glove Box Lid	1	
93	99838 0516 B	Screw, Striker	2	
	99952 0500 B	Washer, Plain	2	
	99971 0500 B	Washer, Spring	2	
94	0317 70 269	Cushion, Glove Box Lid	3	
95	1856 68 860	Indicator (Automatic)	1	

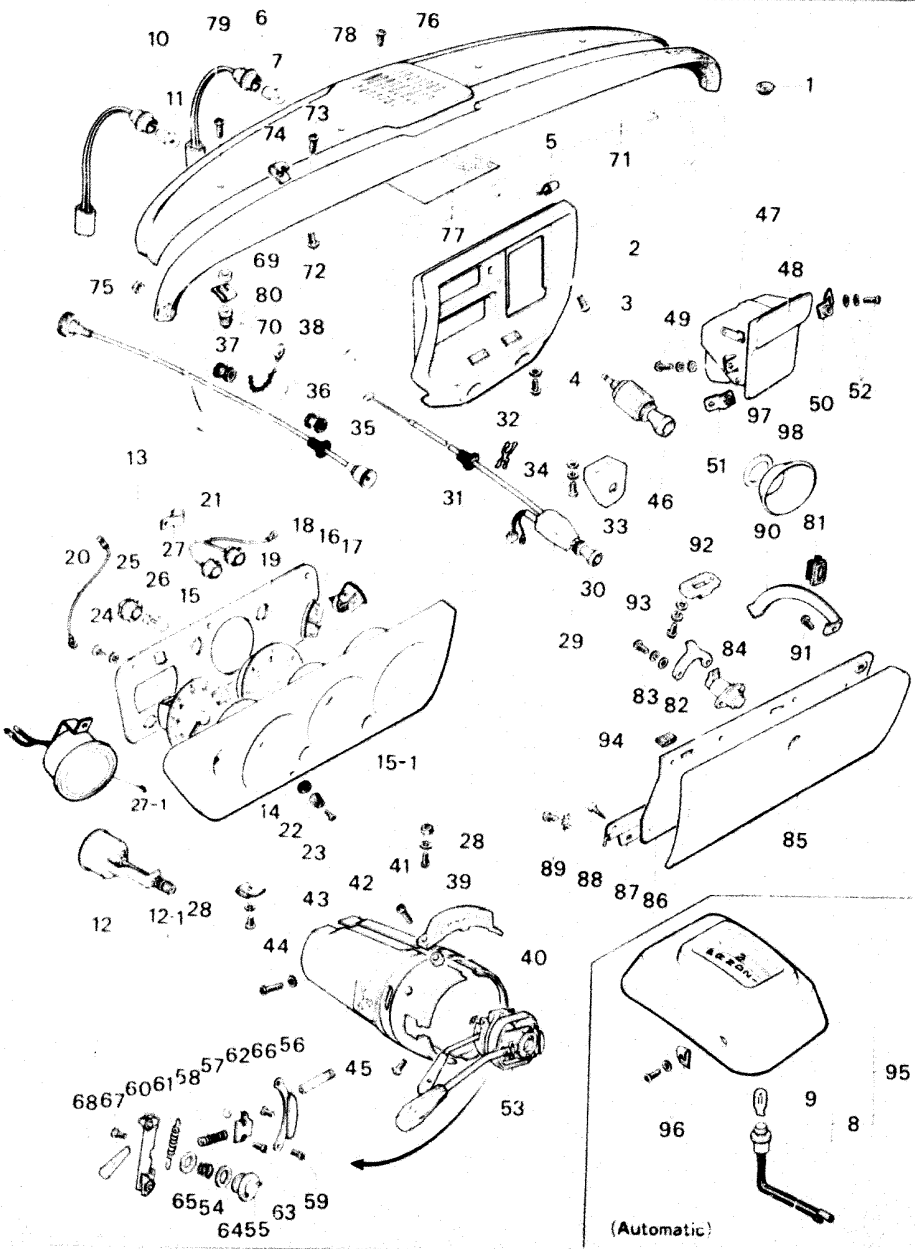

No.	Part Number	Description	Q'ty	Remarks
96	99862 0516B	Screw, Indicator	3	
	99967 0500B	Washer	3	(Automatic)
	99096 0500B	Nut, Spring	3	
97	0305 60 715	Insulator	1	
98	0317 60 721	Protector	1	

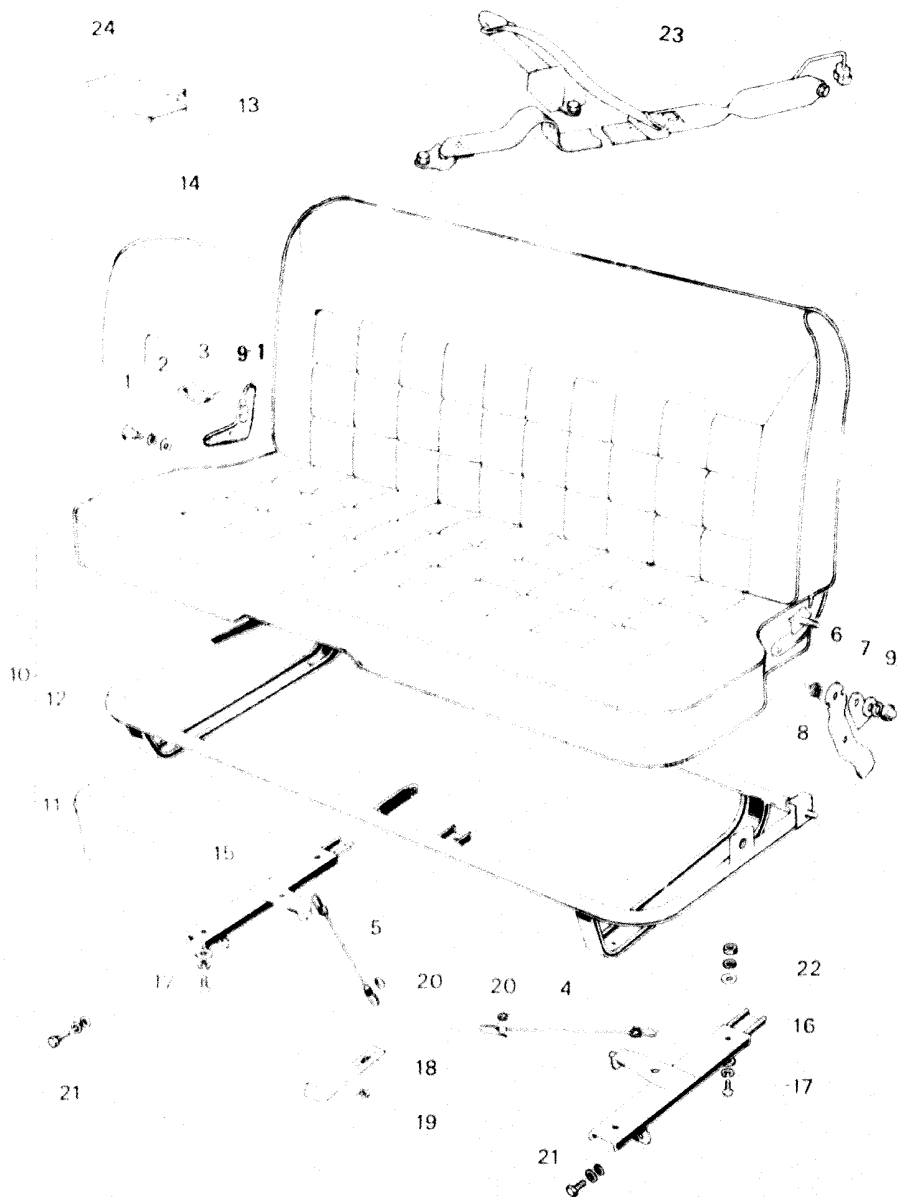

No.	Part Number	Description	Qty	Remarks
-----	-------------	-------------	-----	---------

When ordering the following Seat & Trim,
Add colour code nos. given below after parts number.

- 03 (BLK) - 22 (BEIG) - 52 (BLU)

1	0603 57 102	Pin, Hinge	2	
2	99951 0822	Washer, Plain	2	
	99952 1030	Washer, Plain	2	
3	0603 57 109	Rubber, Stop	2	
•	3875 57 126	Plate, Set	2 77/8 ~ x	
4	0603 57 111	Wire No. 1, Adjuster	1	
5	0603 57 112	Wire No. 2, Adjuster	1	
6	2541 57 121	Plate, Lock	2	
•	3874 57 121	Plate, Lock	1 77/8 ~ x	
7	2541 57 122	Plate, Stopper	2	
•	3874 57 122	Plate, Stopper	2 77/8 ~ x	
8	2541 57 123	Spring (R), Return	1	
•	3874 57 123	Spring (R), Return	1 77/8 ~ x	
	2541 57 124	Spring (L), Return	1	
•	3874 57 124	Spring (L), Lock	1 77/8 ~ x	
9	99945 0600	Nut, Cap	2	
•	99576 0600	Ring, Retaining	2 77/8 ~ x	
	99952 0816	Washer, Plain	4	

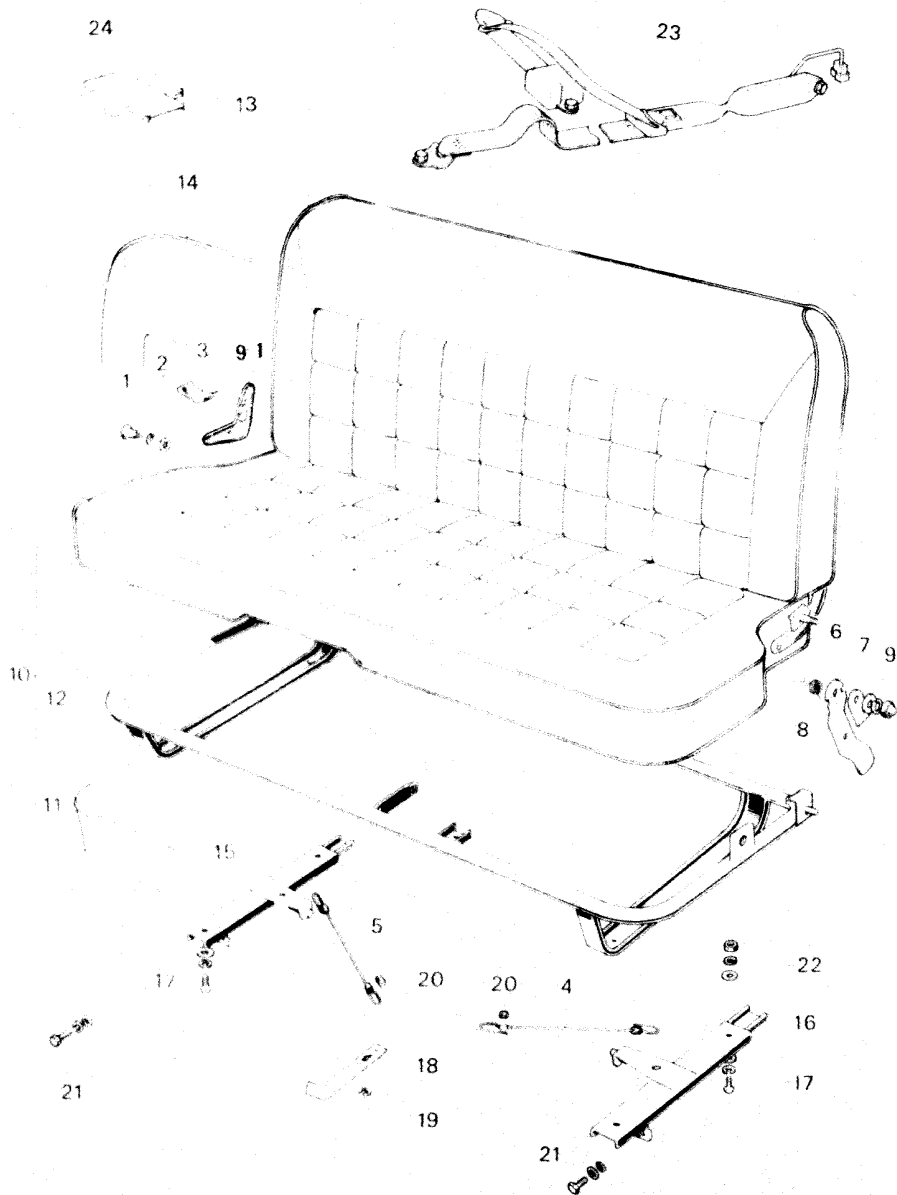

No.	Part Number	Description	Q'ty	Remarks
	99971 0600	Washer, Spring	2	
•	3874 57 125	Shaft, Hinge	2	77/8 ~ X
9-1	3875 57 101	Cover, Seat Hinge (R)	1	
	3875 57 102	Cover, Seat Hinge (L)	1	
10	3875 57 200	©Cushion	1	
•	3875 57 200A	©Cushion	1	77/8 ~ X
11	3875 57 220	© Trim	1	
12	3874 57 400	Frame	1	
•	3874 57 400A	Frame	1	77/8 ~ X
13	3875 57 300	©Seat Back	1	
•	3875 57 300A	©Seat Back	1	77/8 ~ X
14	3875 57 320	© Trim, Seat Back	1	
15	3874 57 650	Slide (R)	1	
16	3874 57 680	Slide (L)	1	
17	99801 0816	Bolt, Slide	4	
	99952 0800	Washer, Plain	4	
	99971 0800	Washer, Spring	4	
18	0662 88 024	Lever, Adjuster	1	

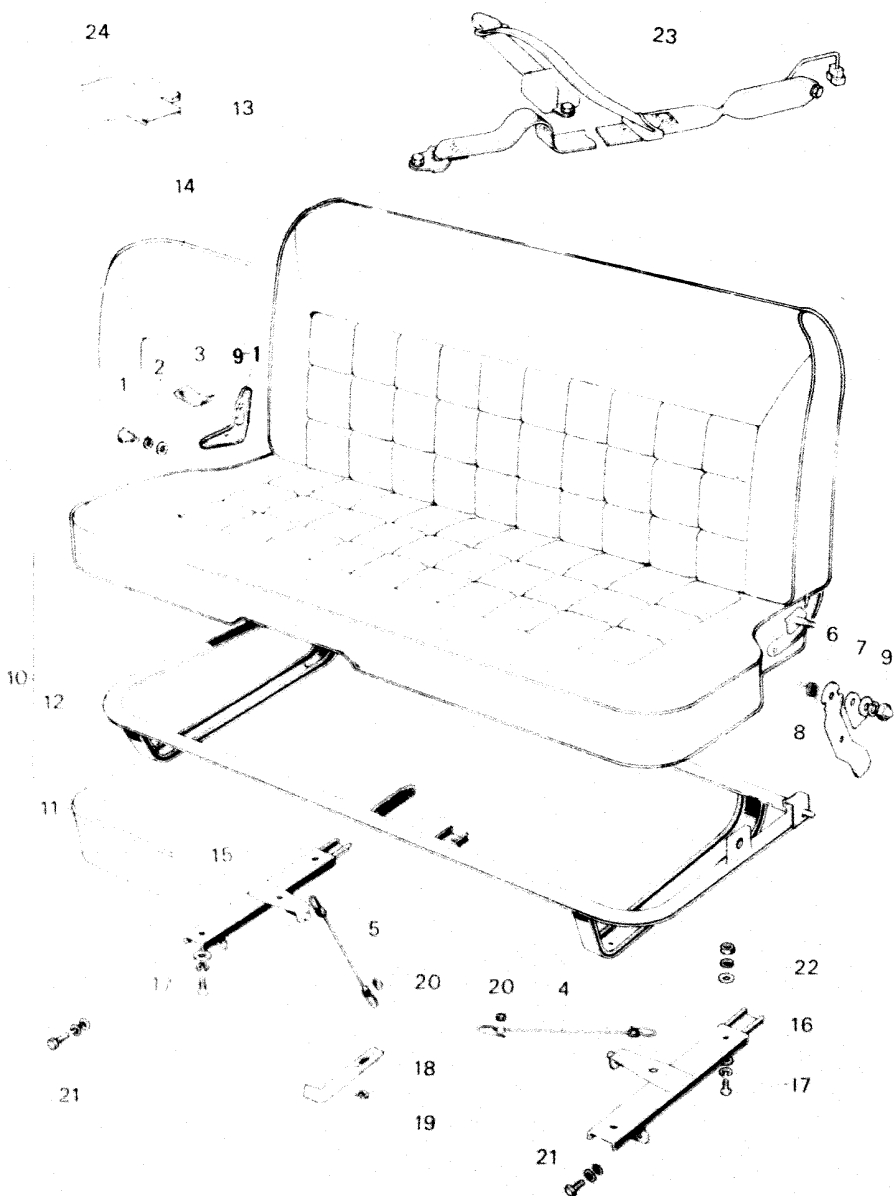

No.	Part Number	Description	Q'ty	Remarks
19	99576 0700	Ring, Retaining-Adjuster Lever	1	
20	0738 57 109	Clip, Adjuster Wire	4	
21	99796 0820	Bolt, Seat	2	
	99952 0800	Washer, Plain (Recipro)	2	
22	99901 0800	Nut, Seat	2	
	99971 0800	Washer, Spring	2	
23	3916 57 900A-00	Belt, Seat (R) TAKATA MAKE	1	
	3770 57 900A-00	Belt, Seat (R) NSK MAKE	1	
•	3770 57 900B-00	Belt, Seat (R) NSK MAKE	1	77/9 ~ Δ
	3916 57 920A-00	Belt, Seat (L) TAKATA MAKE	1	
	3770 57 920A-00	Belt, Seat (L) NSK MAKE	1	77/9 ~ Δ
•	3770 57 920B-00	Belt, Seat (L) NSK MAKE	1	77/9 ~ Δ
24	3794 57 991	Holder	1	

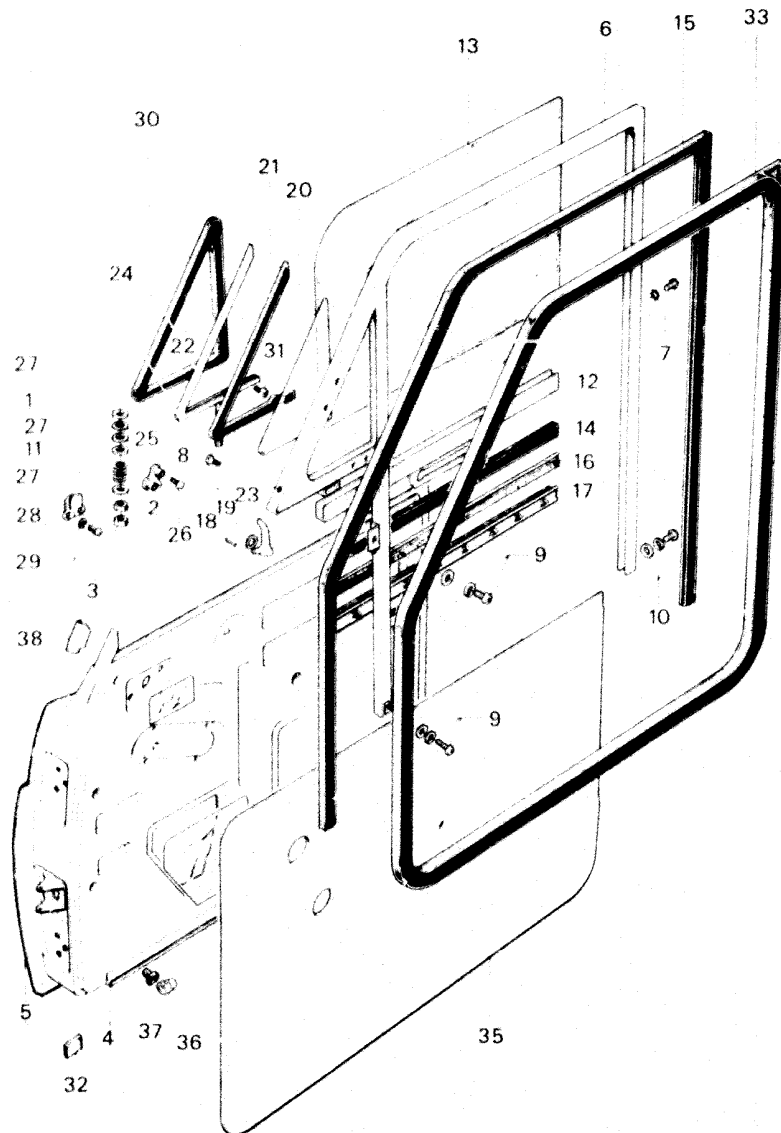

No.	Part Number	Description	Q'ty	Remarks
1	0820 52 403	Washer	4	
2	99906 0600	Nut	2	
3	99907 0600	Nut	2	
4	3790 58 010	Body (R), Door	1	(Fig. No. 5 included)
	3790 59 010	Body (L), Door	1	
5	1819 58 020	Panel (R), Outer	1	
	3790 59 020	Panel (L), Outer	1	
6	0603 58 110A	Frame (R), Sash	1	
	0603 59 110A	Frame (L), Sash	1	
7	99834 0506	Screw, Sash Frame	4	
	99974 0500	Washer, Toothed	4	
8	99831 0612	Screw, Ventilator	4	
9	99833 0612	Screw, Sash Frame	4	
	99951 0618	Washer, Plain	4	
	99971 0600	Washer, Spring	4	
10	99834 0612	Screw, Sash Frame Lower	2	
	99952 0618	Washer, Plain	2	
	99974 0600	Washer, Toothed	2	
11	0115 58 171	Spring, Ventilator	2	
12	0603 58 210	Holder, Door Glass	2	

FRONT SIDE DOOR (GLASS)

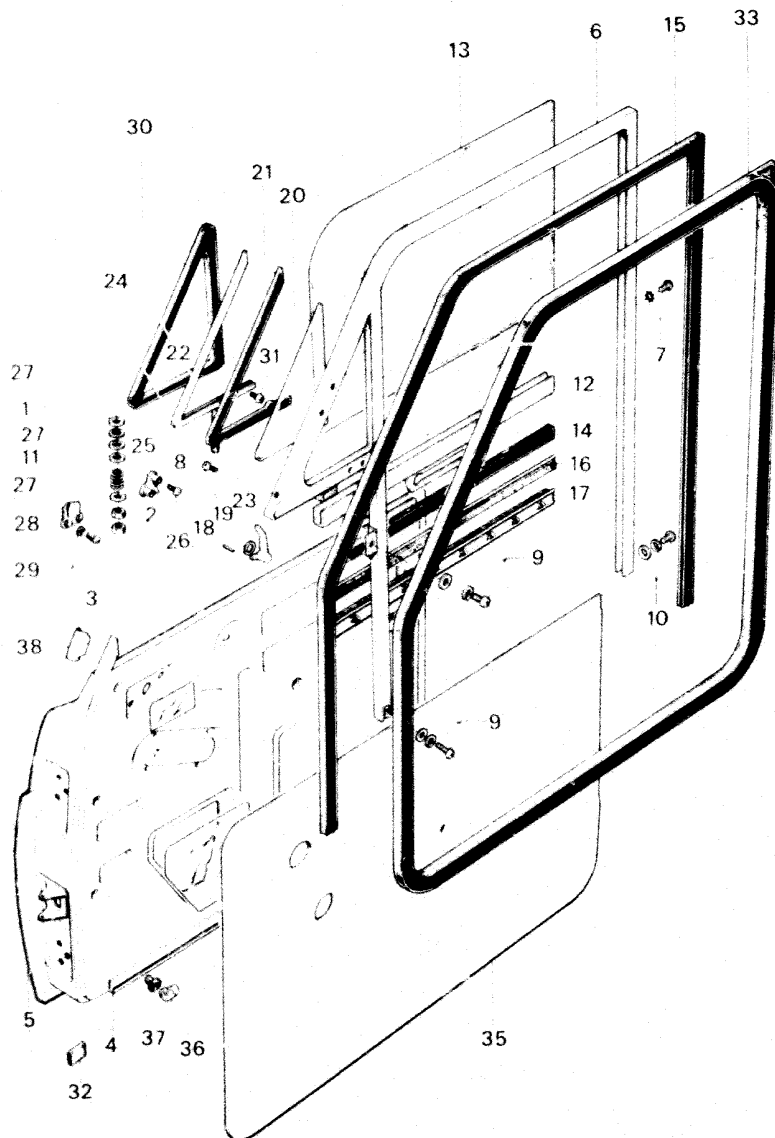

FRONT SIDE DOOR (GLASS)

No.	Part Number	Description	Qty	Remarks
13	0588 58 221B	Glass, Door (Transparent)	2	
•	0588 58 221C	Glass, Door (Transparent)	2 77/2 ~ Δ	Selective use
	1823 58 221A	Glass, Door (Blue Pane)	2	
•	1823 58 221B	Glass, Door (Blue Pane)	2 77/2 ~ Δ (France ○ (Except France))	
14	0588 58 231	Rubber, Holding-Door Glass	2	
15	0588 58 241	Run Channel, Glass	2	
16	0603 58 280A	Weatherstrip, Outer	2	
17	0603 58 290A	Weatherstrip, Inner	2	
	0603 58 410C	Ventilator (R), Door (Transparent)	1	
•	0603 58 410D	Ventilator (R), Door (Transparent)	1 77/2 ~ Δ	
	1823 58 410	Ventilator (R), Door (Blue Pane)	1	Selective use Fig. No. 18 ~ 24 included
•	1823 58 410A	Ventilator (R), Door (Blue Pane)	1 77/2 ~ Δ (France) ○ (Except France)	
	0603 59 410C	Ventilator (L), Door (Transparent)	1	
•	0603 59 410D	Ventilator (L), Door (Transparent)	1 77/2 ~ Δ	
	1823 59 410	Ventilator (L), Door (Blue Pane)	1	
•	1823 59 410A	Ventilator (L), Door (Blue Pane)	1 77/2 ~ Δ (France) ○ (Except France)	
18	0115 58 214	Pin, Spring	2	
19	99972 1000	Washer, Wave	2	
20	0603 58 411B	Glass, Ventilator (Transparent)	2	

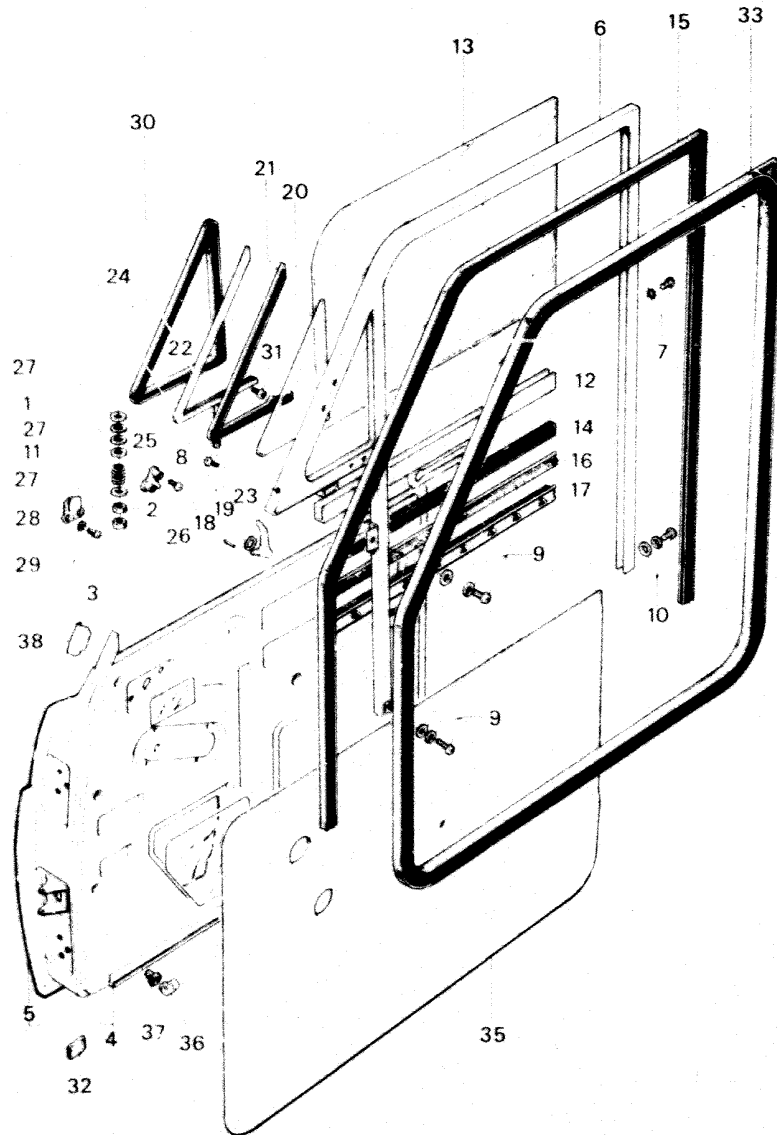

No.	Part Number	Description	Q'ty	Remarks
•	0603 58 411C	Glass, Ventilator (Transparent)	2	77/2 ~ Δ
	1823 58 411	Glass, Ventilator (Blue Pane)	2	
•	1823 58 411A	Glass, Ventilator (Blue Pane)	2	77/2 ~ Δ (France) ○ (Except France)
21	0603 58 412A	Rubber (R), Holding-Glass	1	
	0603 59 412A	Rubber (L), Holding-Glass	1	
22	0603 58 420B	Sash (R), Ventilator	1	
	0603 59 420B	Sash (L), Ventilator	1	
23	0183 58 451	Handle (R), Ventilator Lock	1	
	0183 59 451	Handle (L), Ventilator Lock	1	
24	0603 58 460A	Sash (R), Ventilator	1	Fig. No. 18, 19, 22, 23 included
	0603 59 460A	Sash (L), Ventilator	1	
25	0603 58 430A	Hinge (R), Ventilator	1	
	0603 59 430A	Hinge (L), Ventilator	1	
26	99772 0410	Screw, Ventilator Hinge	4	
27	0187 58 471	Washer	8	
28	0193 58 481	Plate, Lock	2	
29	99833 0408	Screw, Lock Plate	4	
	99971 0400	Washer, Spring	4	
30	0603 58 491C	Rubber (R), Sash-Ventilator	1	

58

59

FRONT SIDE DOOR (GLASS)

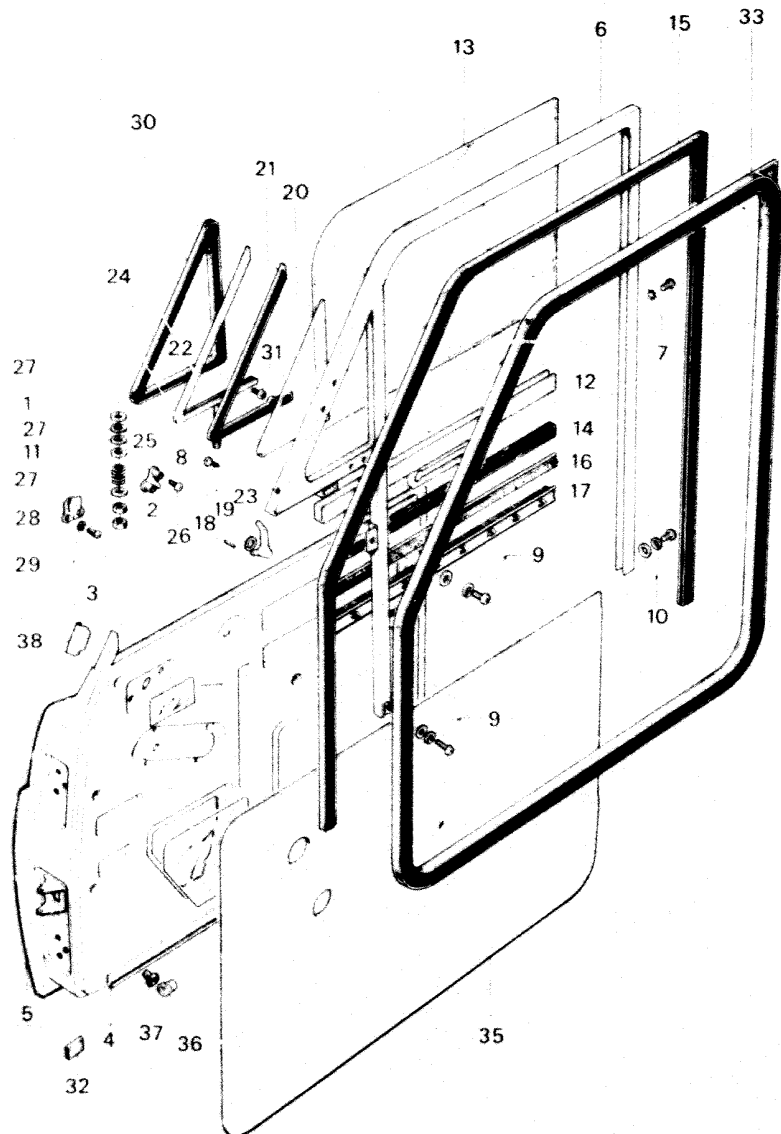

58

59

FRONT SIDE DOOR (GLASS)

No.	Part Number	Description	Qty	Remarks
	0603 59 491C	Rubber (L), Sash-Ventilator	1	
31	99772 0514	Screw, Ventilator	2	
32	0208 58 497	Cushion	2	
33	3874 58 901	Weatherstrip (R)	1	
•	3874 58 901A	Weatherstrip (R)	1	76/12 ~ Δ
	3874 59 901	Weatherstrip (L)	1	
•	3874 59 901A	Weatherstrip (L)	1	76/12 ~ Δ
34	0603 58 904	Pad, Weatherstrip (Rotary)	2	
35	3790 58 910 03	Trim (R), Door (BLK)	1	
	3790 58 910 22	Trim (R), Door (BEIG)	1	
	3790 58 910 52	Trim (R), Door (BLU)	1	
	3790 59 910 03	Trim (L), Door (BLK)	1	
	3790 59 910 22	Trim (L), Door (BEIG)	1	
	3790 59 910 52	Trim (L), Door (BLU)	1	
36	0208 58 921	Fastener, Door Trim	16	
37	0187 58 922	Rubber, Seal-Fastener	16	
38	1854 58 951A	Pad (R), Door Body	1	
	1854 59 951A	Pad (L), Door Body	1	

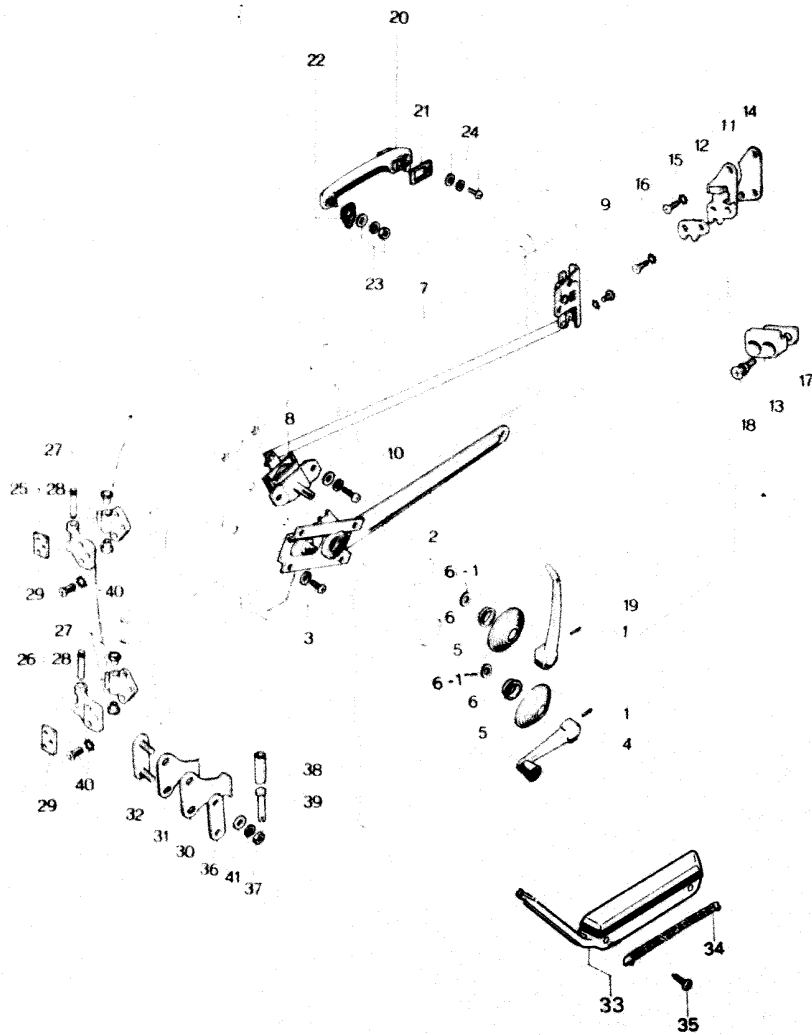

No.	Part Number	Description	Q'ty	Remarks
1	0100 58 272A	Pin, Tapered	2	
2	0603 58 300A	Regulator (R), Window	1	
	0603 59 300A	Regulator (L), Window	1	
3	99833 0512	Screw, Regulator	8	
	99971 0600	Washer, Spring	8	
4	0118 58 370A01	Handle (R), Regulator (BLK)	1	
	0118 59 370A01	Handle (L), Regulator (BLK)	1	
5	0118 58 391 01	Escutcheon, Regulator Handle (BLK)	4	
•	0118 58 391A01	Escutcheon, Regulator Handle (BLK)	4	77/10 ~ Δ
•	0118 58 392	Crown, Escutcheon	4	77/10 ~ Discarded
6-1	0259 58 305B	Gasket, Regulator Handle	4	
7	2651 58 500B	Lock (R), Door	1	
	2651 59 500B	Lock (L), Door	1	
8	2651 58 600	Lock, Inner	2	
9	99832 0612	Screw, Door Lock	6	
	99974 0600	Washer, Toothed	6	
10	99833 0616	Screw, Inner Lock	4	
	99952 0600	Washer, Plain	4	
	99971 0600	Washer, Spring	4	
11	0259 58 570	Striker (R), Door Lock	1	

58

59

FRONT SIDE DOOR (LOCK)

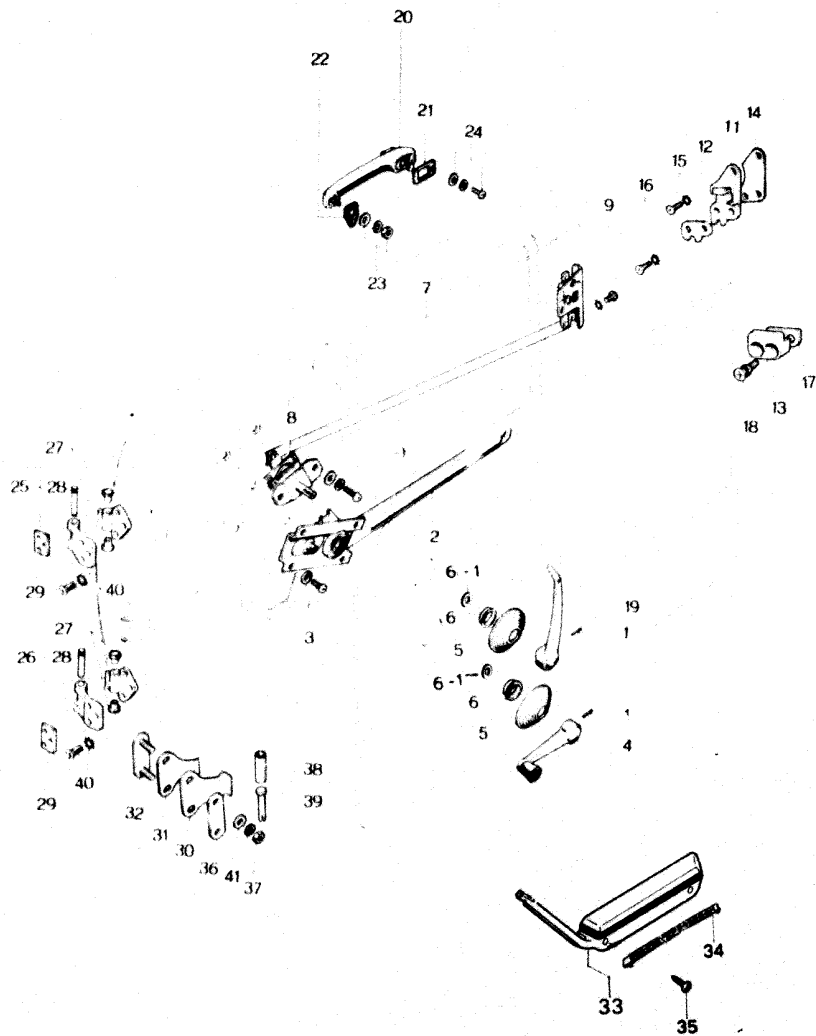

58

59

FRONT SIDE DOOR (LOCK)

No.	Part Number	Description	Q'ty	Remarks
	0259 59 570	Striker (L), Door Lock	1	
12	0259 58 581	Rack (R), Door Striker	1	
	0259 59 581	Rack (L), Door Striker	1	
13	2350 58 582	Block, Antiburst	2	
14	0187 58 592A	Seat, Striker	2	
15	99761 0620	Screw, Door Striker	2	
	99974 0600	Washer, Toothed	2	
	99975 0600	Washer, Toothed	2	
16	99761 0630	Screw, Door Striker	4	
	99974 0600	Washer, Toothed	4	
	99975 0600	Washer, Toothed	4	
17	2350 58 593	Shim, Antiburst Block	2	
18	99761 0630	Screw, Antiburst Block	4	
	99974 0600	Washer, Toothed	4	
19	0115 58 651B	Handle (R), Inner	1	
	0115 59 651B	Handle (L), Inner	1	
20	2651 58 670	Handle, Outer	2	
21	0603 58 674	Seat No. 1	2	
22	0603 58 675	Seat No. 2	2	
23	99906 0600	Nut, Outer Handle	2	

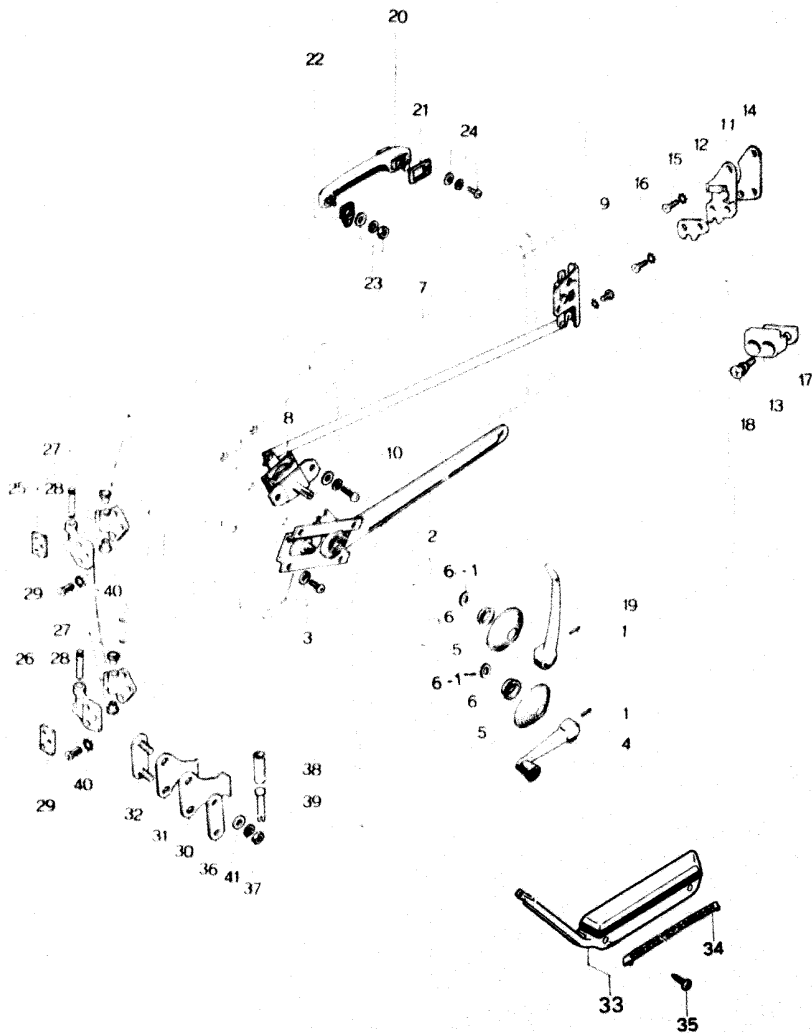

No.	Part Number	Description	Q'ty	Remarks
	99952 0600	Washer, Plain	2	
	99971 0600	Washer, Spring	2	
24	99833 0612	Screw, Outer Handle	2	
	99952 0600	Washer, Plain	2	
	99971 0600	Washer, Spring	2	
25	0588 58 710	Hinge "A", Upper	2	
26	0588 58 760	Hinge "B", Lower	2	
27	0223 58 721	Bush	8	
28	0187 58 731	Pin, Hinge	4	
29	0603 58 741A	Spacer	4	
30	0603 58 811	Spring, Check-Door	2	
31	0603 58 812	Spring, Check Sub-Door	2	
32	0603 58 820A	Plate, Set-Door Checker	2	
33	3875 69 370-00	Rest (R), Arm (BLK)	1	
•	3875 69 370-20	Rest (R), Arm (BEIG)	1	
	3875 69 370-50	Rest (R), Arm (BLU)	1	
	3875 69 390-00	Rest,(L), Arm (BLK)	1	
•	3875 69 390-20	Rest (L), Arm (BEIG)	1	
	3875 69 390-50	Rest (L), Arm (BLU)	1	
34	3875 69 373-00	Cover (BLK)	2	
•	3875 69 373-20	Cover (BEIG)	2	
	3875 69 373-50	Cover (BLU)	2	
35	99830 0620	Screw, Arm Rest	4	

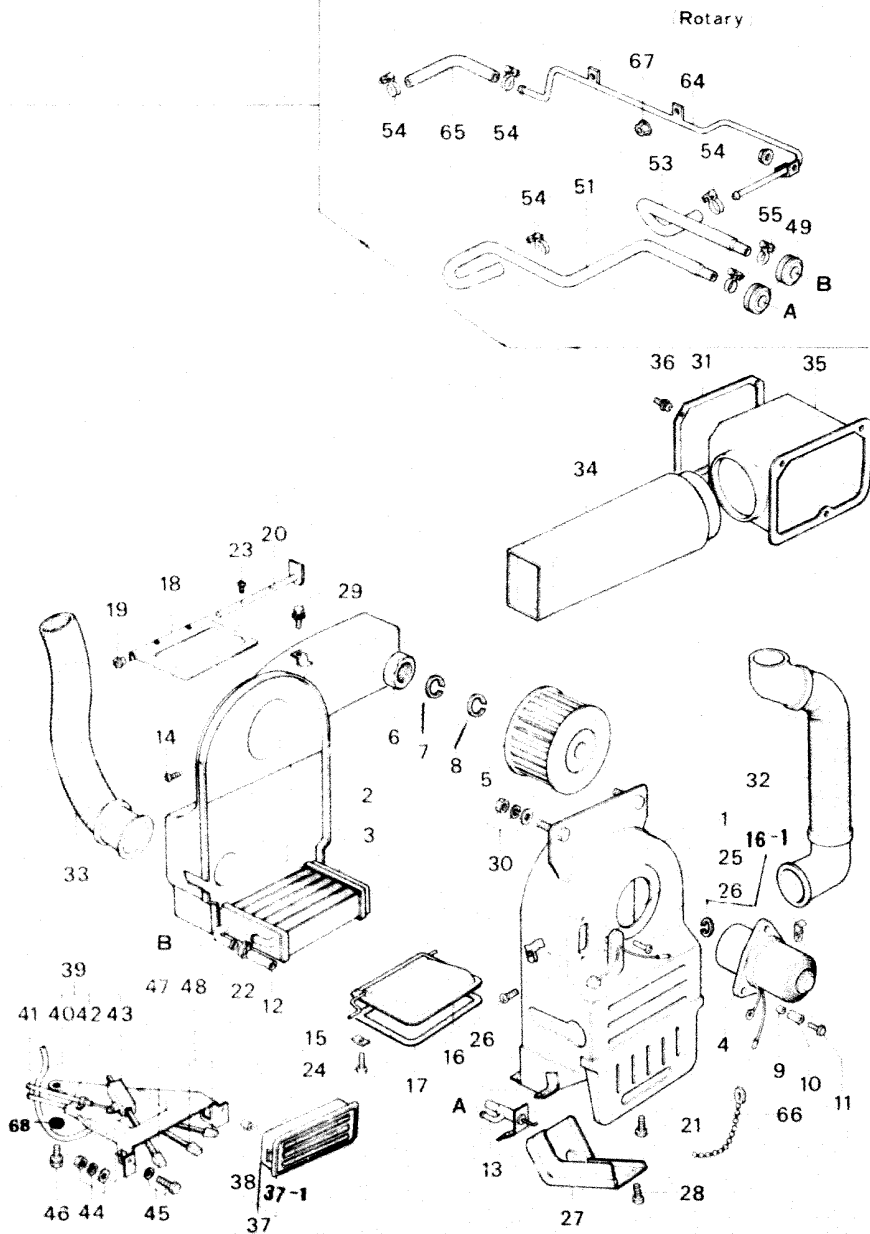

No.	Part Number	Description	Q'ty	Remarks
	1854 61 080D	Heater Set	1	
	1854 61 080E	Heater Set	1	77/6 ~ Δ
•	3792 61 140B	Heater Unit (Fig. No. 1, ~ 26 included)	1	
•	3792 61 140C	Heater Unit (Fig. No. 1, ~ 26 included)	1	77/6 ~ x
1	2677 76 121B	Case	1	
2	2677 76 122A	Plate	1	
3	2677 76 123	Core	1	
4	3792 76 124A	Motor	1	
5	3792 76 456	Fan	1	
6	0866 76 472A	Nut	1	
7	0866 76 475	Washer, Plain	1	
8	0866 76 476	Washer, Plain	1	
9	2677 76 129	Bush	3	
10	2677 76 130	Ring, Rubber	3	
11	3792 76 131	Screw, Set	3	
12	2677 76 133	Hose, Water	1	
13	2677 76 134A	Valve, Water	1	
14	0260 76 135	Screw	0	
15	2677 76 135	Spring	2	
16	2677 76 136B	Valve, Air	1	
16-1	0866 76 474	Washer, Plain	1	

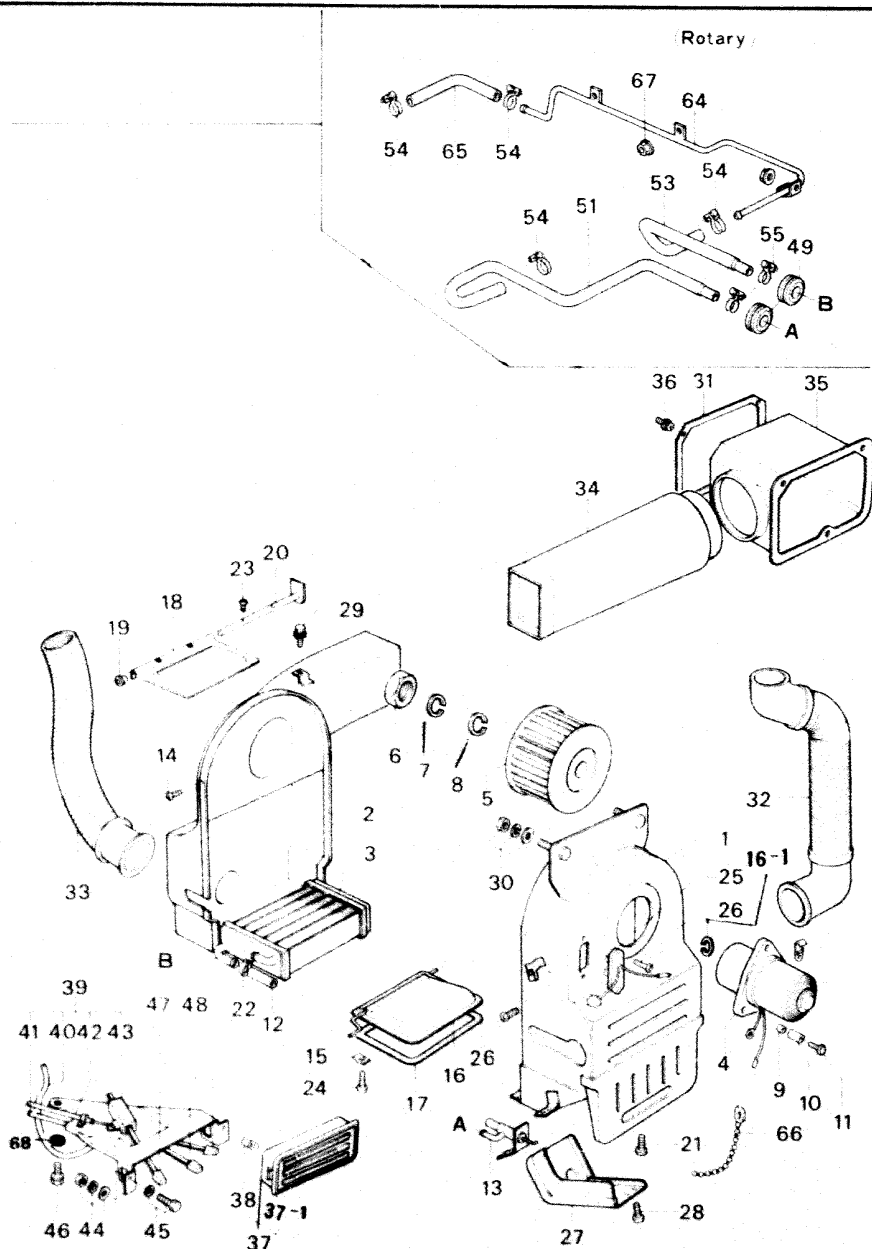

No.	Part Number	Description	Qty	Remarks
17	2677 76 143	Gasket	1	
18	2677 76 145	Valve, Air	1	
19	2677 76 146	Bush	2	
20	2677 76 147 A	Shaft	1	
21	99833 0412	Screw	2	
	99971 0400	Washer Spring	2	
22	99282 2200	Band Hose	2	
23	99833 0306	Screw	2	
24	99833 0410	Screw	2	
25	3792 76 150	Resistance	1	
26	99833 0510	Screw	3	
27	2677 61 145 A	Cover	1	
28	99833 0412	Screw	3	
29	99796 0812	Bolt, Heater Unit & Body	1	
30	99940 0800	Nut, Heater Unit	2	
31	3874 61 155	Packing	1	
32	2677 61 240 A	Hose (R) Defroster	1	

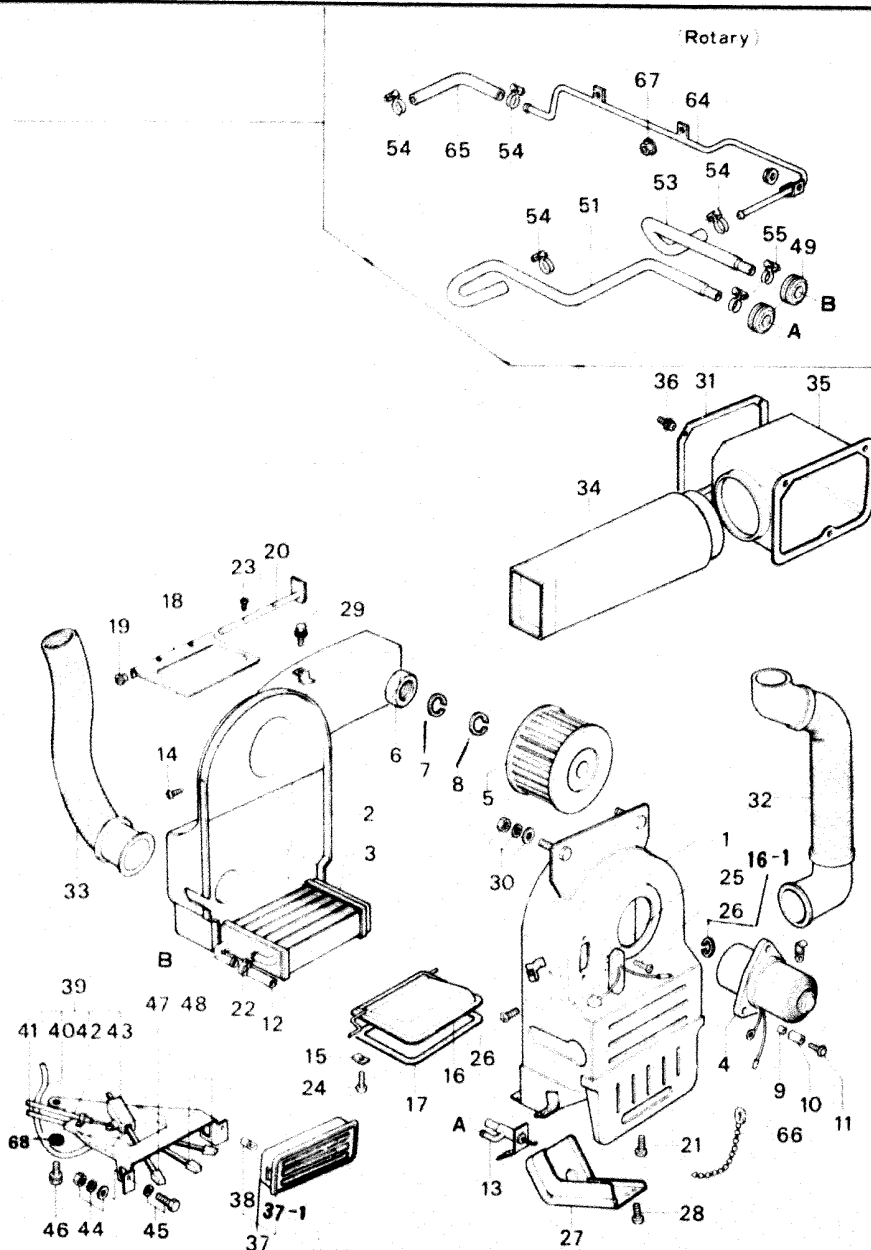

No.	Part Number	Description	Q'ty	Remarks
46	99786 0520	Bolt, Heater Control	1	
47	1823 76 442	Knob No. 1	1	
48	1823 76 443	Knob No. 2	2	
49	0233 61 479	Grommet	2	
50	2844 61 211C	Hose No. 1, Water (1600cc)	1	(Recipro)
1820	61 211B	Hose No. 1, Water (1800cc)	1	
51	1854 61 211	Hose No. 1, Water	1	
52	2844 61 215D	Hose No. 2, Water (1600cc)	1	(Recipro)
1820	61 215B	Hose No. 2, Water (1800cc)	1	
53	1854 61 212	Hose No. 2, Water	1	
54	99282 2600	Band, Hose	4	
55	99282 2200	Band, Hose	2	
56	0395 13 170A	Connector, Hose (Fig No 57 included)	1	
57	99922 2900	Nut	1	
58	99564 2900	Gasket, Connector	1	
59	1820 61 125	Clip	2	(1800cc)
60	1823 61 126	Clip	1	(Recipro)
61	1304 61 241	Clip (1600cc)	1	
62	99794 0620	Bolt	2	(1800cc)
99871	0600	Washer, Spring	2	

(Rotary)

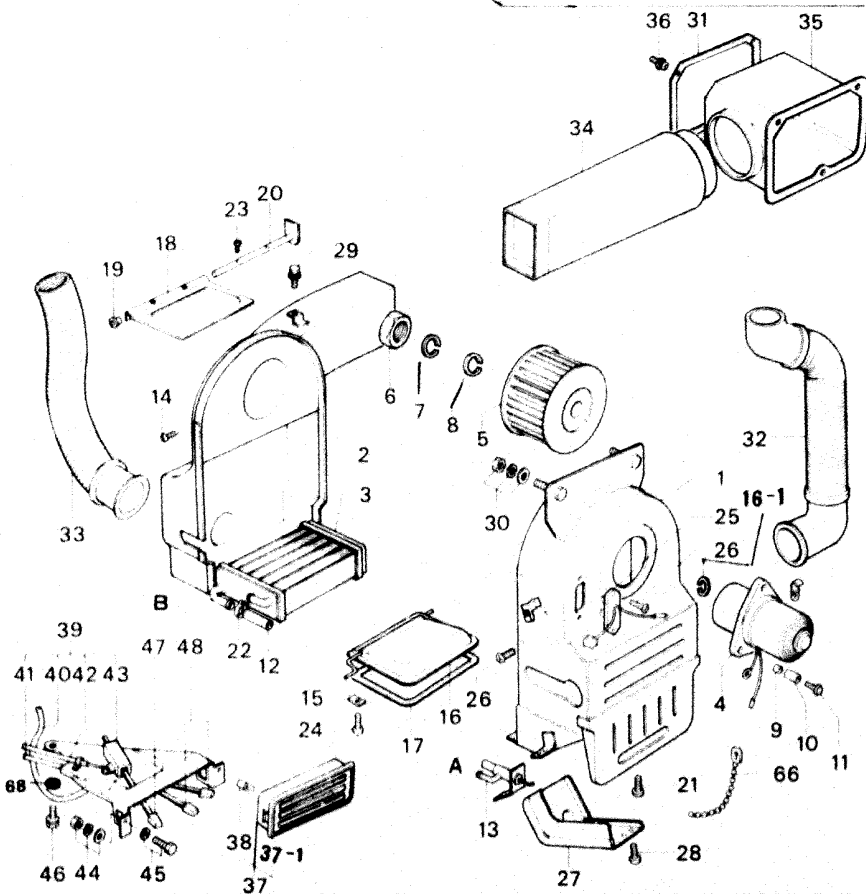
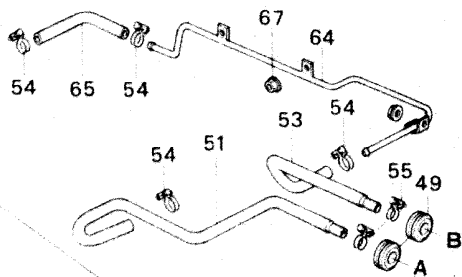

No.	Part Number	Description	Q'ty	Remarks
63	99953 0600	Washer, Flan (1600cc)	2	(Recipro)
63	99786 0612	Bolt, Clip (1600cc)	1	
64	1854 61 220A	Pipe, Water	1	
65	0824 61 183B	Hose, Water	1	
66	99288 1608	Band	1	
67	99940 0602	Nut	2	
68	0193 65 627	Washer	1	

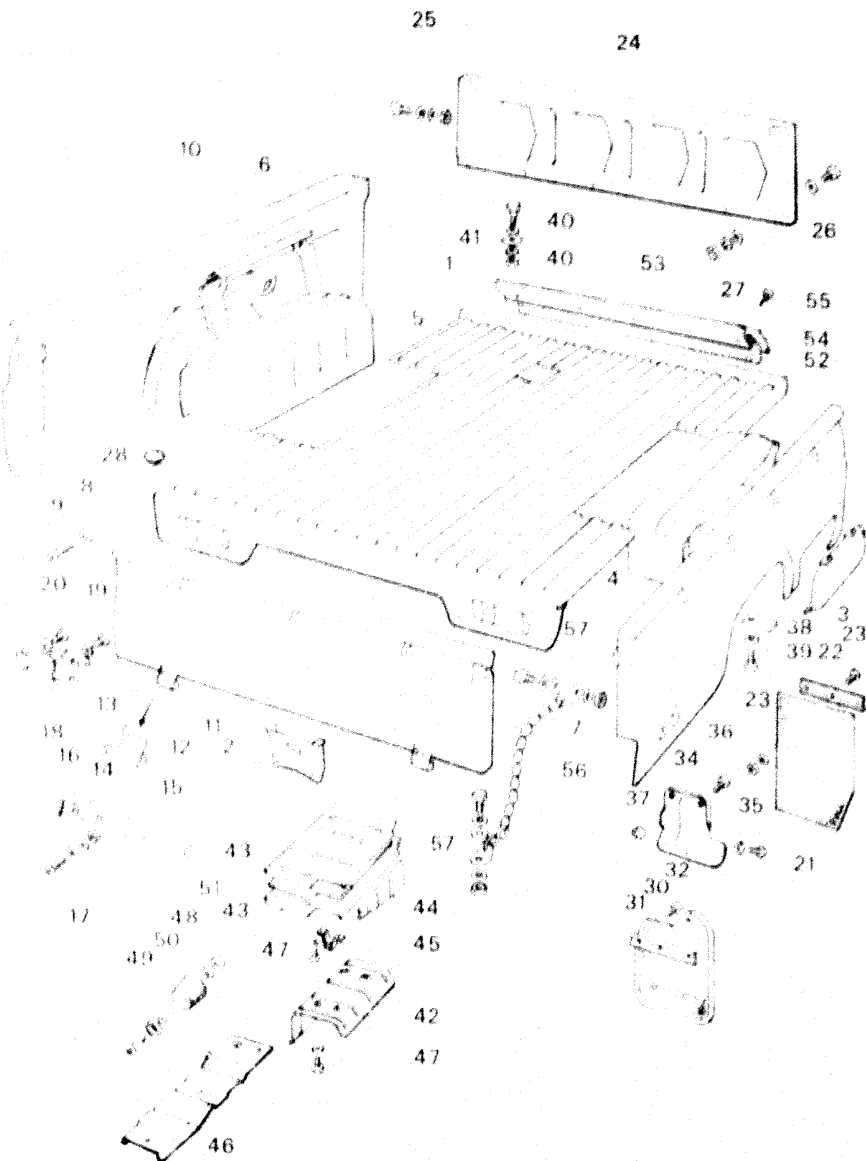

No.	Part Number	Description	Q'ty	Remarks
	3790 65 010	Box	1	
1	3790 65 020	Board Floor (Fig. No.2, included)	1	
2	2651 65 140A	Bracket Number Plate Holder	1	
3	3790 65 500	Cover Service	1	
• 3-1	1854 65 531A	Rubber, Service Cover	1	
4	1854 65 201A	House (R), Tire	1	
5	1854 65 210A	House (L), Tire	1	
6	1854 65 310	Bracket Condense Tank	1	
7	3790 65 430	Plate (R), Side	1	
8	1823 65 437A	Protector	2	
9	99864 0408	Screw Tapping Protector	2	
10	3790 65 460	Plate (L), Side	1	
11	0603 65 490C	Door, Rear (Fig. No. 12, ~ 16, included)	1	
12	0183 65 551	Hinge	2	

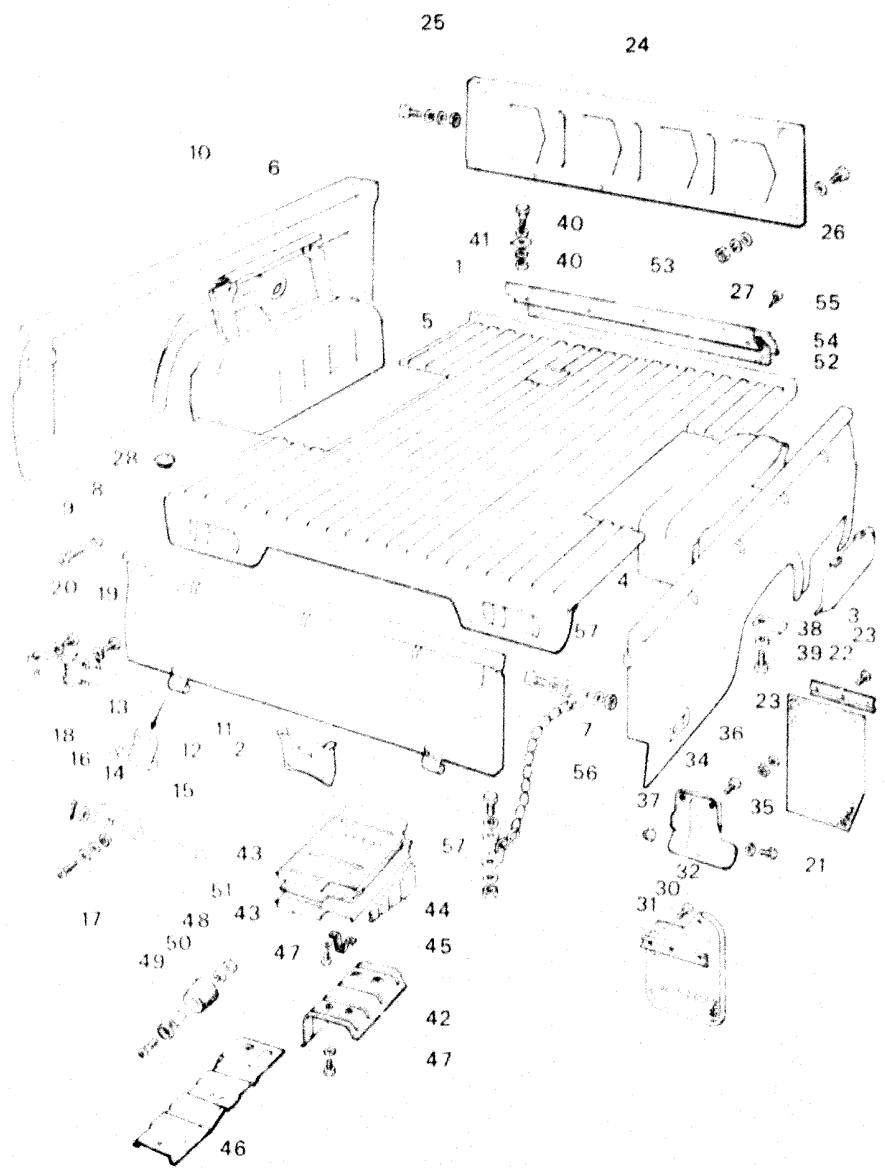

No.	Part Number	Description	Qty	Remarks
13	99251 0818	Rivet	4	
14	0183 65 552	Hinge, Box Rear Door	2	
15	83 65 553	Pin, Hinge	2	
16	0024 65 554	Washer, Hinge	2	
	99221 3020	Pin, Split	2	
17	99833 0820	Screw Door Hinge	4	
	99901 0800	Nut	4	
	99952 0800	Washer, Plain	4	
	99971 0800	Washer, Spring	4	
18	0603 65 560A	Shutter Door	2	
19	99834 0820	Screw, Shutter	2	
	99971 0800	Washer, Spring	2	
20	99834 0835	Screw, Shutter	2	
	99971 0800	Washer, Spring	2	
21	1854 65 855B	Flap	1	
22	1854 65 856	Washer	1	
23	99833 0618	Screw, Flap	3	
	99906 0600	Nut	3	
	99953 0600	Washer, Plain	3	
24	1823 65 900	Plate, Front	1	

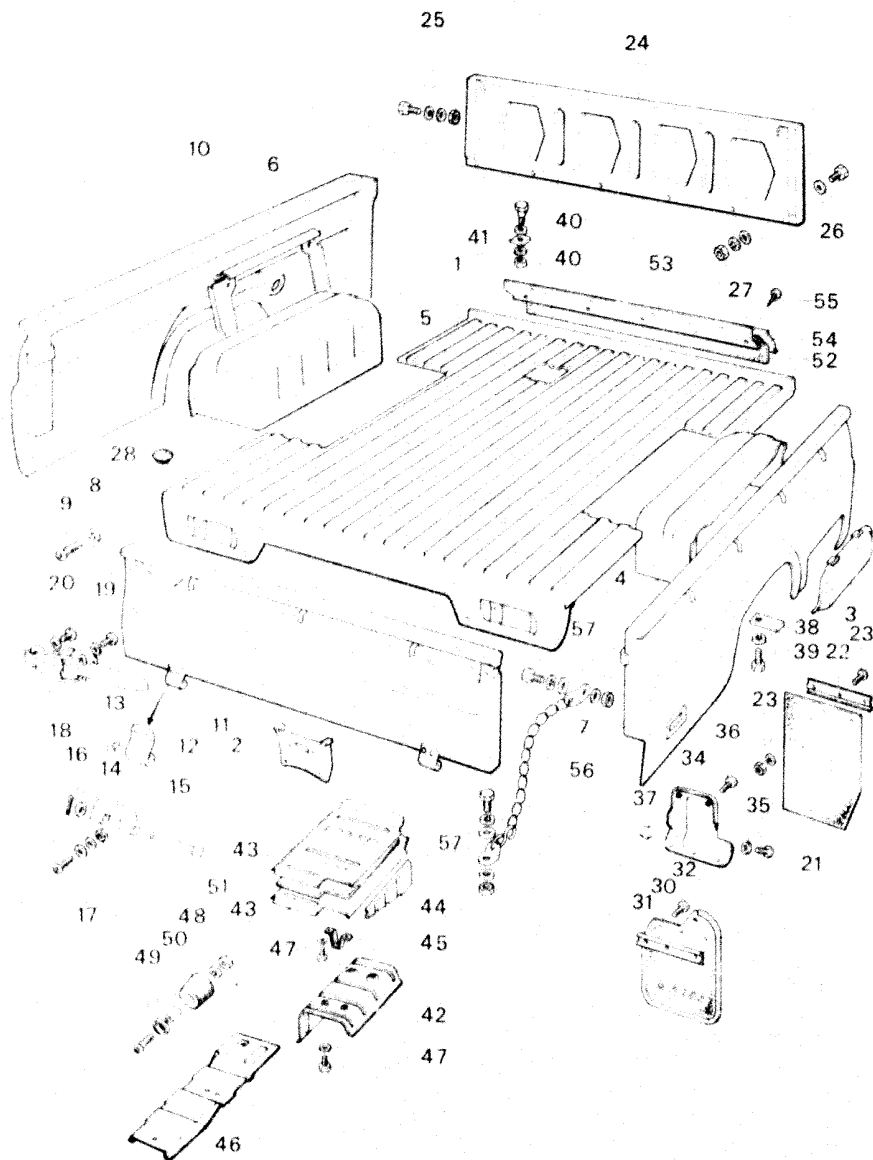

No.	Part Number	Description	Q'ty	Remarks
25	99795 0820	Bolt, Front Plate	4	
	99906 0800	Nut	6	
	99952 0800	Washer, Plain	10	
	99971 0800	Washer, Spring	6	
26	99795 0816	Bolt, Front Plate	4	
	99952 0800	Washer, Plain	4	
27	99906 0800	Nut	4	
	99952 0800	Washer, Plain	4	
	99971 0800	Washer, Spring	4	
28	0222 66 971	Rubber Seal (Rotary)	4	
29	0603 65 851	Flap, Mud Guard (Recipro)	2	
30	1854 65 851B	Flap (R), Mud Guard	1	
	1854 65 951B	Flap (L), Mud Guard	1	
31	1854 65 853	Washer, Flap Set	2	
32	99796 0616	Screw, Flap	6	
33	99906 0600	Nut	6	
		(Recipro)		
99953 0600	Washer, Plain		6	

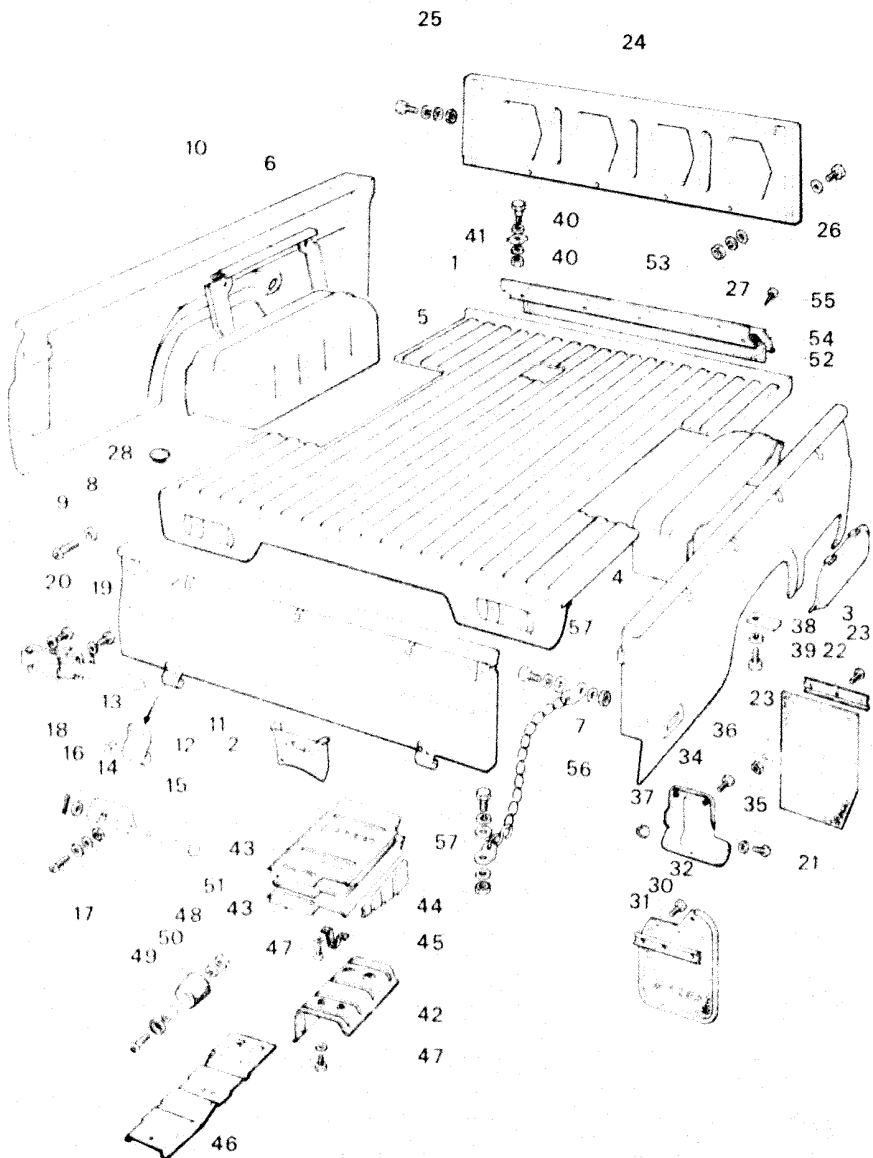

No.	Part Number	Description	Q'ty	Remarks
99940	0600	Nut	6	
34	1854 65 870	Bracket (R). Flap	1	
	1854 65 970	Bracket (L). Flap	1	
35	99769 0616B	Bolt, Bracket	2	
	99952 0618B	Washer, Plain	2	
36	99796 0616	Bolt, Bracket	4	
37	99910 0601	Grommet, Screw	2	
38	3874 65 014	Shim, Box Set	8	
39	997501 1235	Bolt, Box Set	4	
	99940 1200	Nut	4	
40	997501 1235	Bolt, Box Set	4	
	99940 1200	Nut	4	
41	3874 65 014	Shim, Box Set	8	
42	1854 65 711A	Insulator, Lower	1	
43	1854 65 721	Insulator No 1 - Upper	2	
44	1854 65 722	Insulator No 2 - Upper	1	
45	1854 65 730	Bracket, Insulator	1	

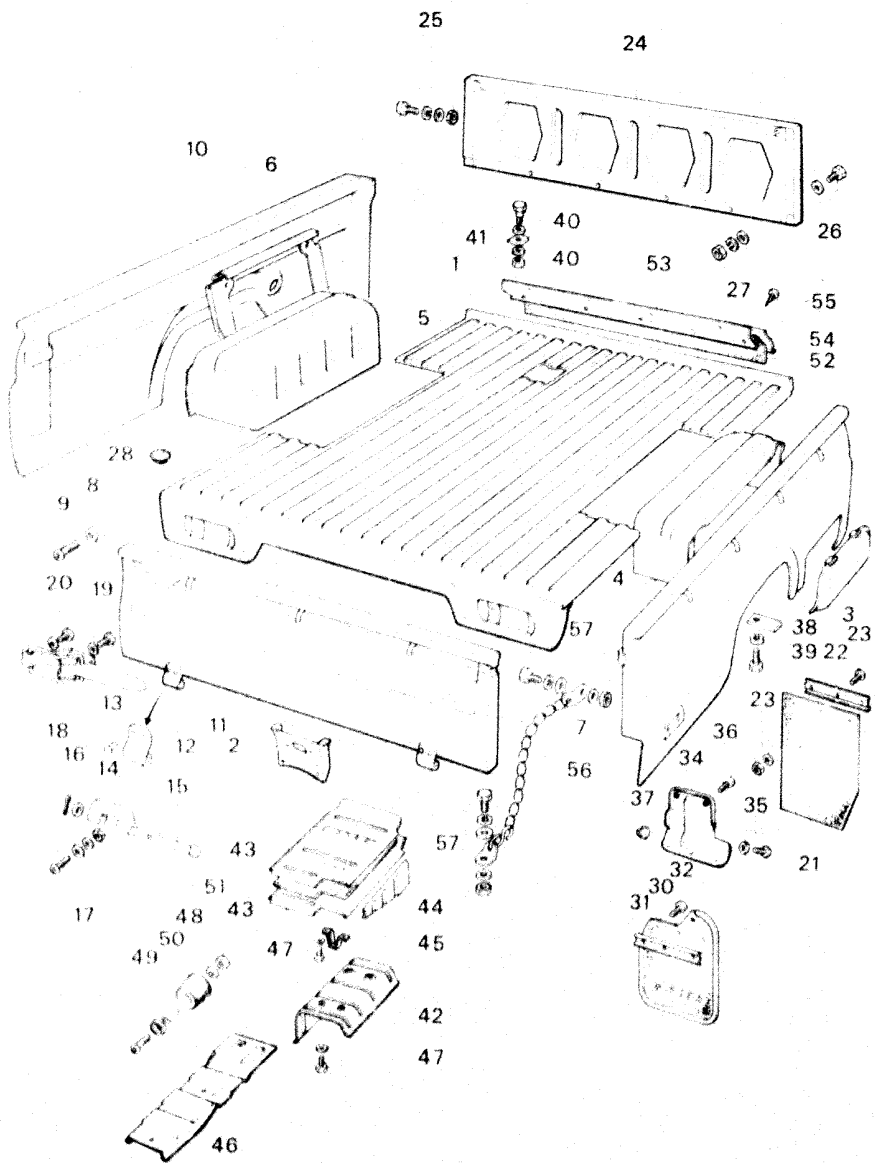

No.	Part Number	Description	Q'ty	Remarks
46	1854 65 741	Insulator No. 3	1	
47	99796 0616	Bolt, Insulator	14	
	99952 0618	Washer, Plain	14	
	99952 1030	Washer, Plain	2	
	0111 40 358	Insulator	2	
48	0559 65 055	Rubber, Stop-Door	2	
49	99834 0830	Screw, Stop Rubber	2	
	0014 65 734	Seat, Screw	2	
50	0727 65 052A	Spacer, Door Stop Rubber	2	
51	99901 0800	Nut, Door Stop Rubber	2	
	99971 0800	Washer, Spring	2	
52	3790 65 751	Rubber, Seal	1	
53	3790 65 752	Plate, Seal No. 1	1	
54	1854 65 753	Plate, Seal No. 2	1	
55	99864 0512	Screw, Tapping	6	
56	1823 65 810C	Chain	2	
57	99811 1025	Bolt	4	
	99921 1000	Nut	4	
	99951 1030	Washer, Plain	4	
	99952 1000	Washer, Plain	4	
	99971 1000	Washer, Spring	4	

LAMPS (FRONT SIDE)

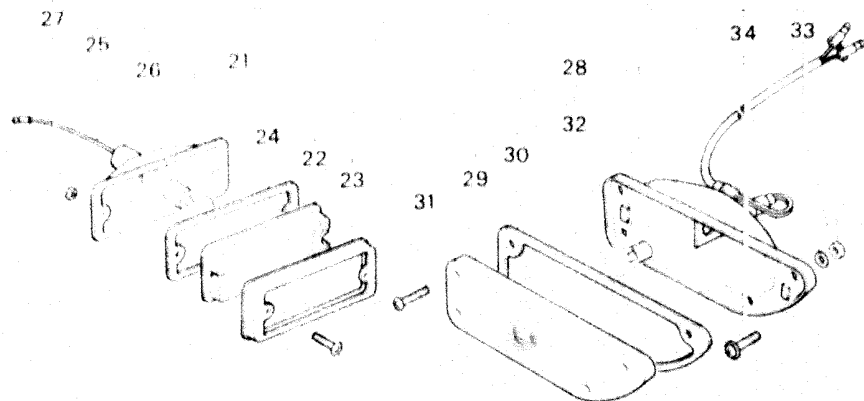
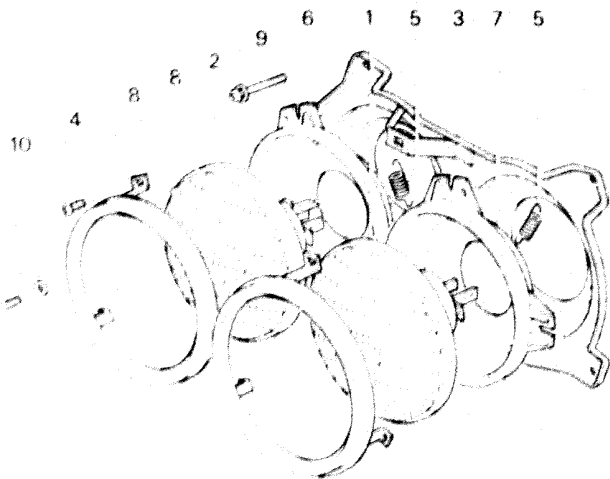

LAMPS (FRONT SIDE)

No.	Part Number	Description	Qty	Remarks
1	0183 66 021	Beam Sealed 12V 37.5W	2	
2	2801 66 022	Beam Sealed 12V 37.5 50W	2	Ord By 2980 87 012
3	1854 66 031	Housing R	1	
	1854 66 041	Housing L	1	
4	0275 87 007	Screw	12	
5	2850 87 012	Spring	4	
6	0727 87 012	Holder R Lamp	1	
	0727 87 022	Holder L Lamp	1	
7	0727 87 013	Holder R Lamp	1	
	0727 87 023	Holder L Lamp	1	
8	0727 87 014	Holder Lamp Front	4	
9	0727 87 016	Screw Adjust	8	
10	99786 0616B	Screw	8	
	99953 0600	Washer Plain	8	
	99971 0600	Washer Spring	8	
	2885 89 661	Lamp (R) Head	1	
	2885 89 666	Lamp (L) Head	1	
				(Recipro)
11	0183 66 021	Beam Sealed (12V 37.5W)	2	
12	2801 66 022	Beam Sealed (12V 37.5 50W)	2	Ord By 2980 87 012

66

87

LAMPS (FRONT SIDE)

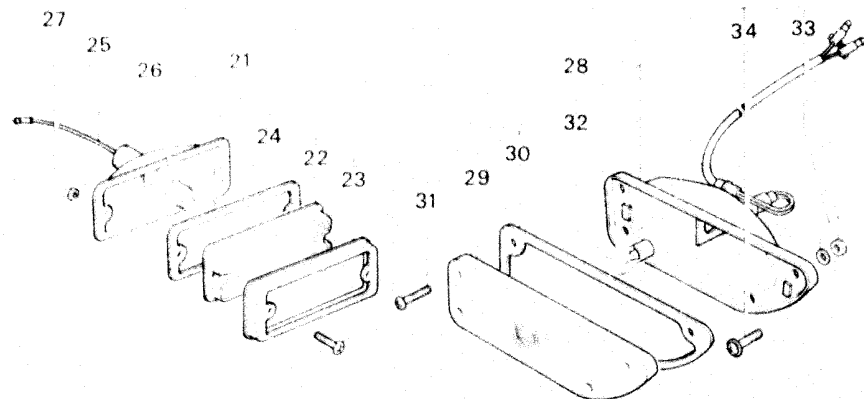
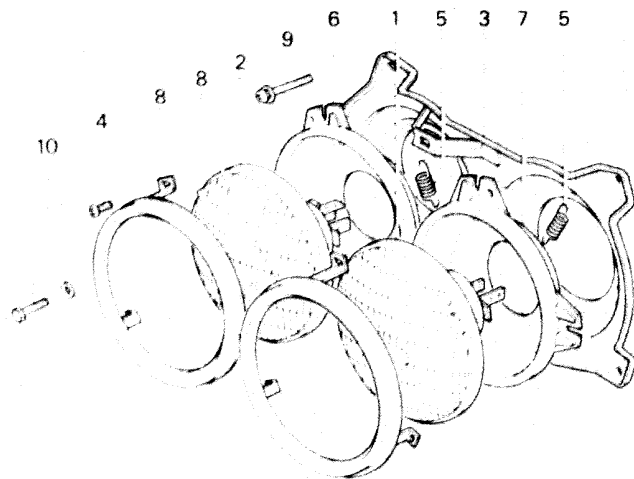

-224-

3-D9

66

87

LAMPS (FRONT SIDE)

No.	Part Number	Description	Qty	Remarks
13	2651 66 024	Ring, Retaining	4	
14	2651 66 025	Ring No. 1 (R), Mounting	1	
	2651 66 055	Ring No. 1 (L), Mounting	1	
15	2651 66 026	Ring No. 2 (R), Mounting	1	
	2651 66 056	Ring No. 2 (L), Mounting	1	
16	2651 66 031	Screw, Adjust	8	
17	2651 66 032	Spring	4	Recipro
18	0223 66 025A	Screw	12	
19	0223 66 070	Cord, Head Lamp	2	
20	00833 0512	Screw	8	
	00052 0500	Washer, Plain	8	
	00071 0500	Washer, Spring	8	
21	2244 89 663	Lamp (R), Side Marker	1	
	2244 89 668	Lamp (L), Side Marker	1	
22	2244 87 191	Globe	2	
23	2244 87 192	Rim	2	
24	2244 87 194	Rubber (R), Seal	1	
	2244 87 195	Rubber (L), Seal	1	
25	2244 87 196	Cord	2	

-226-

66

87

LAMPS (FRONT SIDE)

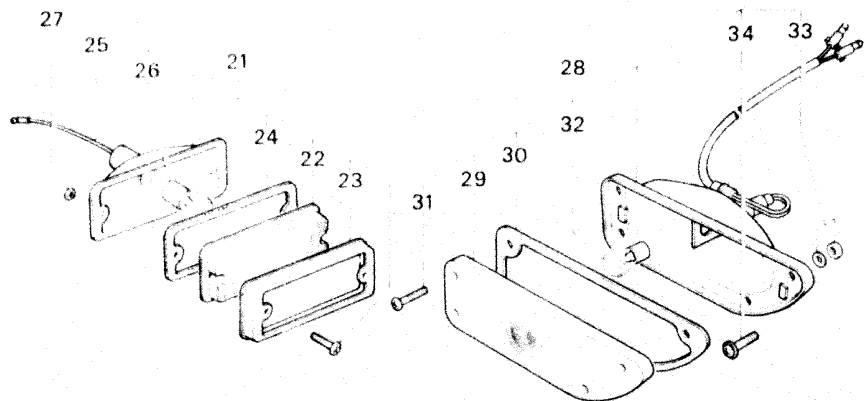
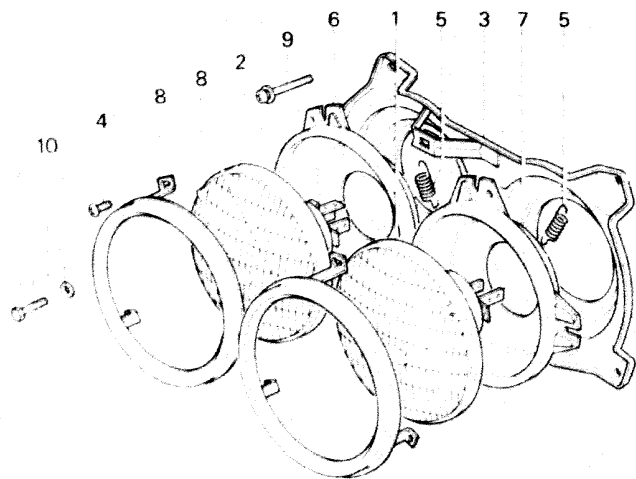

-224-

3-E9

LAMPS (FRONT SIDE)

66

87

No.	Part Number	Description	Q'ty	Remarks
26	99701 2080	Bulb	2	
27	99773 0420	Screw Side Marker Lamp	4	
	99906 0400	Nut	4	
28	1854 89 662	Lamp (R) Front Turn Signal	1	
	1854 89 667	Lamp (L) Front Turn Signal	1	
29	2244 66 091	Lens (R)	1	
	2244 66 111	Lens (L)	1	
30	0259 66 094 A	Rubber (R) Seal	1	
	0259 66 114	Rubber (L) Seal	1	
31	0259 66 095	Screw Lamp Globe	8	
32	99701 4278	Bulb	2	

-227-

66 87

LAMPS (FRONT SIDE)

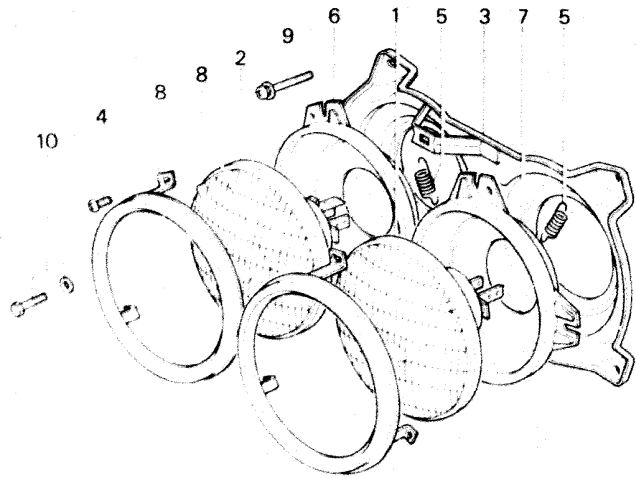

66 87

LAMPS (FRONT SIDE)

No.	Part Number	Description	Q'ty	Remarks
33	99906 0500	Nut, Front Turn Signal Lamp	4	
	99952 0500	Washer, Spring	4	
84	88740 0512	Screw, Front Turn Signal Lamp (Recipro)	4	

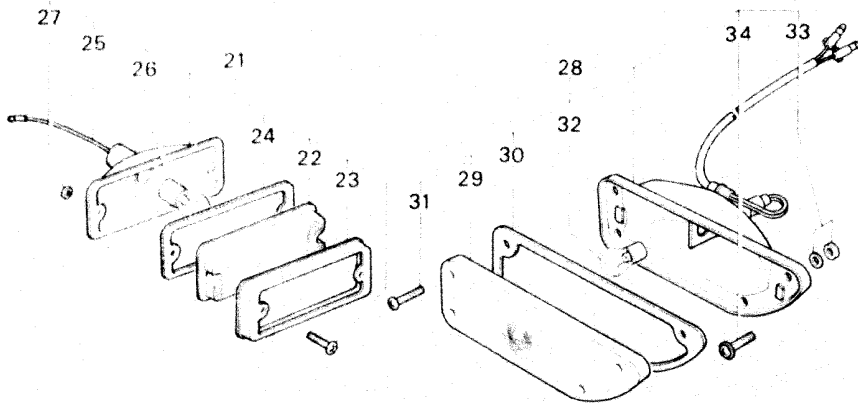

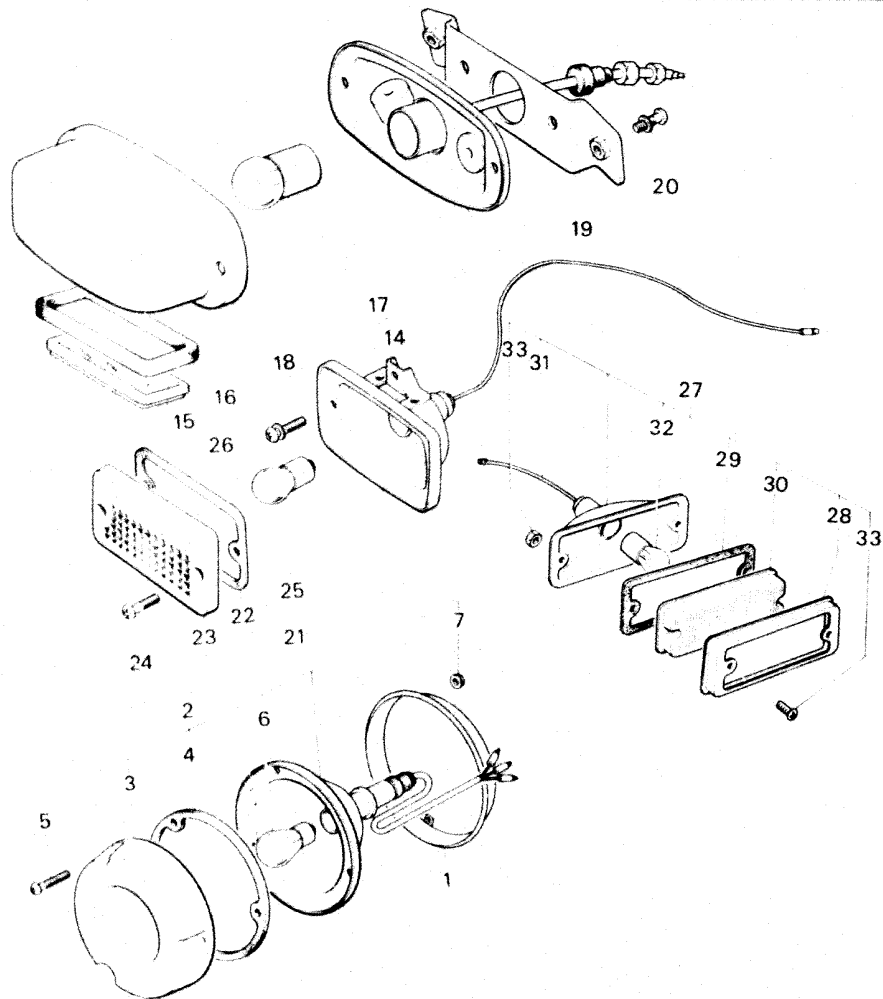

No.	Part Number	Description	Q'ty	Remarks
1	2627 66 201A	Ring, Rear Combination Lamp	4	
2	1854 89 664	Lamp, Rear Combination	4	
3	0738 87 061	Lens	4	
4	0738 87 063	Gasket	4	
5	0710 87 126	Screw	12	
6	99701 4278	Bulb	4	
7	99940 0500	Nut	12	
8	3906 89 664	Lamp, Rear Combination	2	
9	99773 0410	Screw	4	
10	1823 66 212	Gasket	2	
11	1823 66 213	Lens	2	(Recipro)
12	99701 4237	Bulb	2	
13	99940 0502	Nut	4	
14	3900 89 665	Lamp, Licence	1	
15	0136 66 091A	Lens	1	
16	0136 66 092	Gasket	1	
17	99701 2080	Bulb	1	

66

87

LAMPS (REAR SIDE)

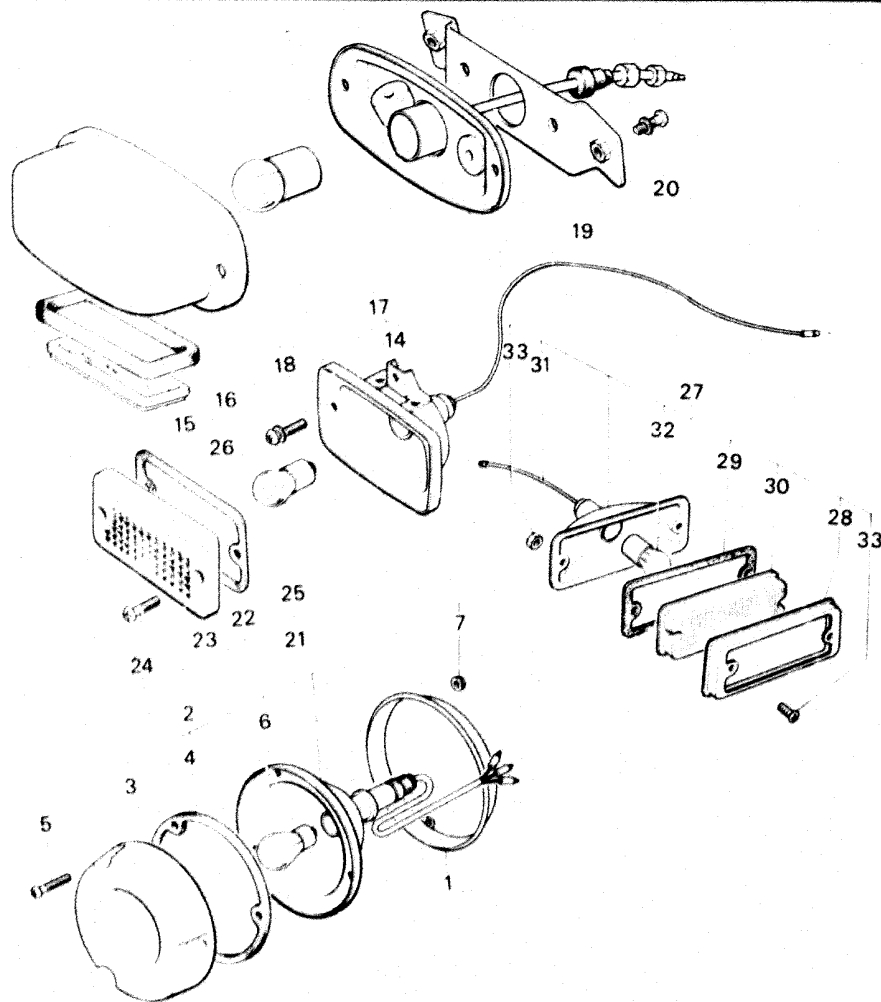

66

87

LAMPS (REAR SIDE)

No.	Part Number	Description	Qty	Remarks
18	0136 66 094A	Cover	1	
19	2651 66 220A	Holder, Licence Lamp	1	
20	99833 0620	Screw, Holder	2	
	99971 0600	Washer, Spring	2	
	99906 0600	Nut	2	
21	1823 66 330 A	Lamp, Back Up	2	
22	0710 87 102	Gasket	2	
23	0710 87 103	Lens	2	
24	0710 87 104	Screw	4	
25	99700 8120	Bulb	2	
26	99797 0512	Bolt, Back Up Lamp	1	
	99952 0516	Washer, Plain	1	
27	2244 89 673	Lamp (R), Side Marker	1	
	2244 89 678	Lamp (L), Side Marker	1	
28	2244 87 192	Rim	2	
29	2244 87 194	Rubber (R), Seal	1	
	2244 87 195	Rubber (L), Seal	1	

LAMPS (REAR SIDE)

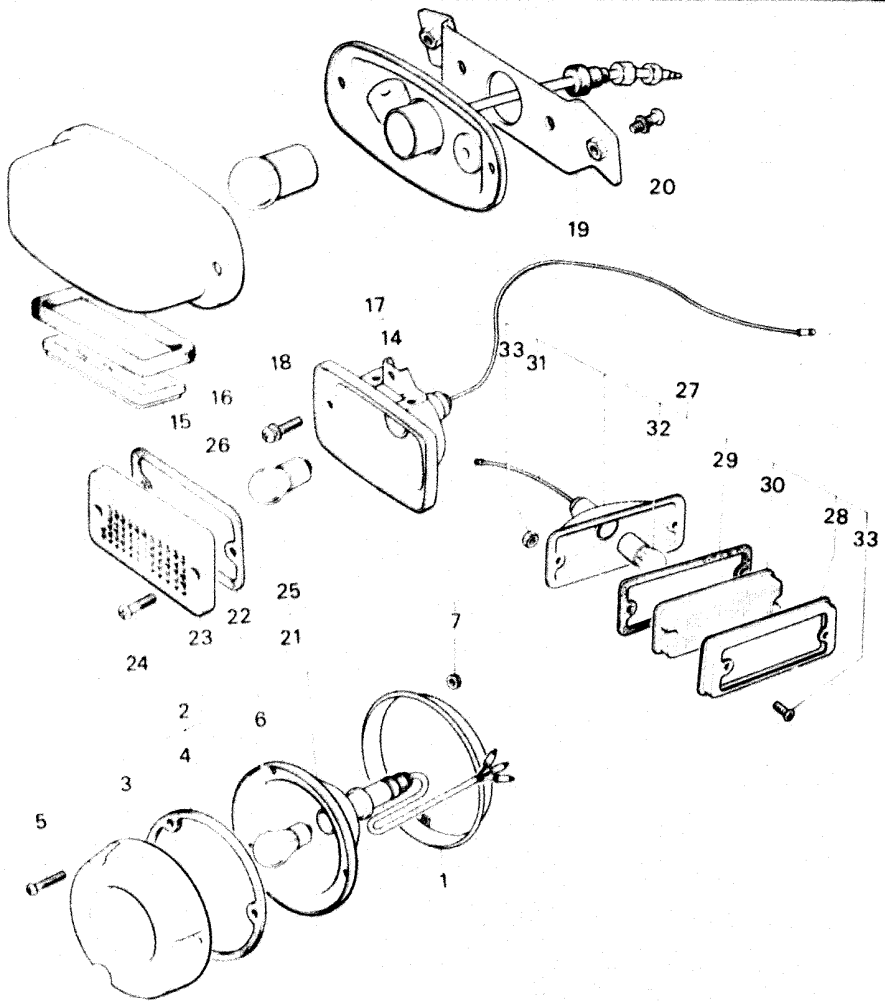

LAMPS (REAR SIDE)

No.	Part Number	Description	Qty	Remarks
30	2244 87 201	Globe	2	
31	2244 87 206	Cord	2	
32	99701 2080	Bulb	1	
33	99773 0420	Screw	4	
	99906 0400	Nut	4	

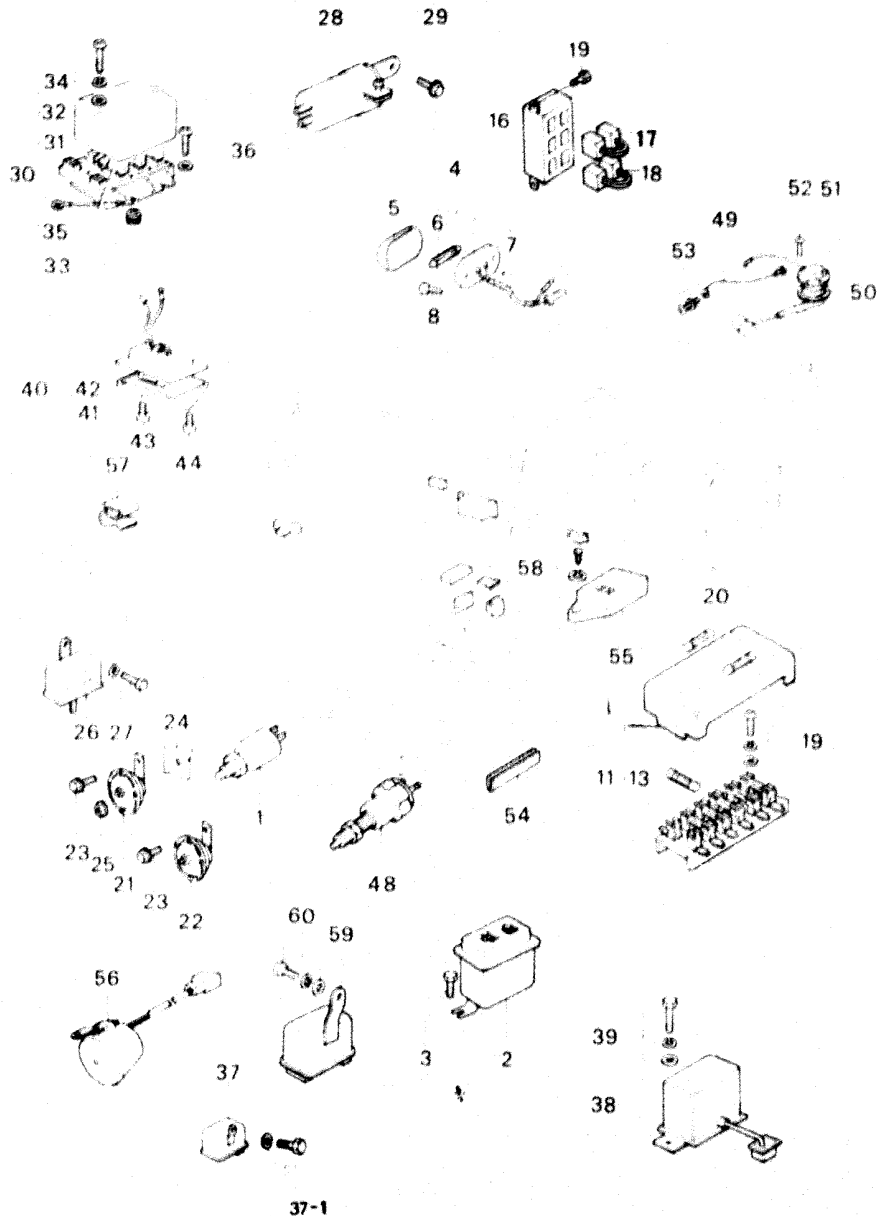
ELECTRIC EQUIPMENT (BODY)
(SWITCH & RELAY)

37-1

ELECTRIC EQUIPMENT (BODY)
(SWITCH & RELAY)

No.	Part Number	Description	Q'ty	Remarks
1	2691 18 660	Switch Kick Down (Automatic)	1	
2	1540 60 930	Relay Turn Signal	1	
3	99796 0610	Bolt Turn Signal Relay	2	
4	0702 66 290	Lamp Interior	1	
5	0243 66 152	Globe	1	
6	99701 5050	Bulb	1	
7	1854 66 295	Cord	1	
8	99863 0412	Screw Interior Lamp	2	
9	1881 66 840	Unit Flasher Hazard	1	(Recipro)
10	99796 0610	Bolt Unit	1	
11	3790 66 730	Block Fuse	1	
12	3776 66 732	Cover (Recipro)	1	
	3775 66 732	Cover (Rotary)	1	

66 **67** **ELECTRIC EQUIPMENT (BODY)**
(SWITCH & RELAY)

66 **67** **ELECTRIC EQUIPMENT (BODY)**
(SWITCH & RELAY)

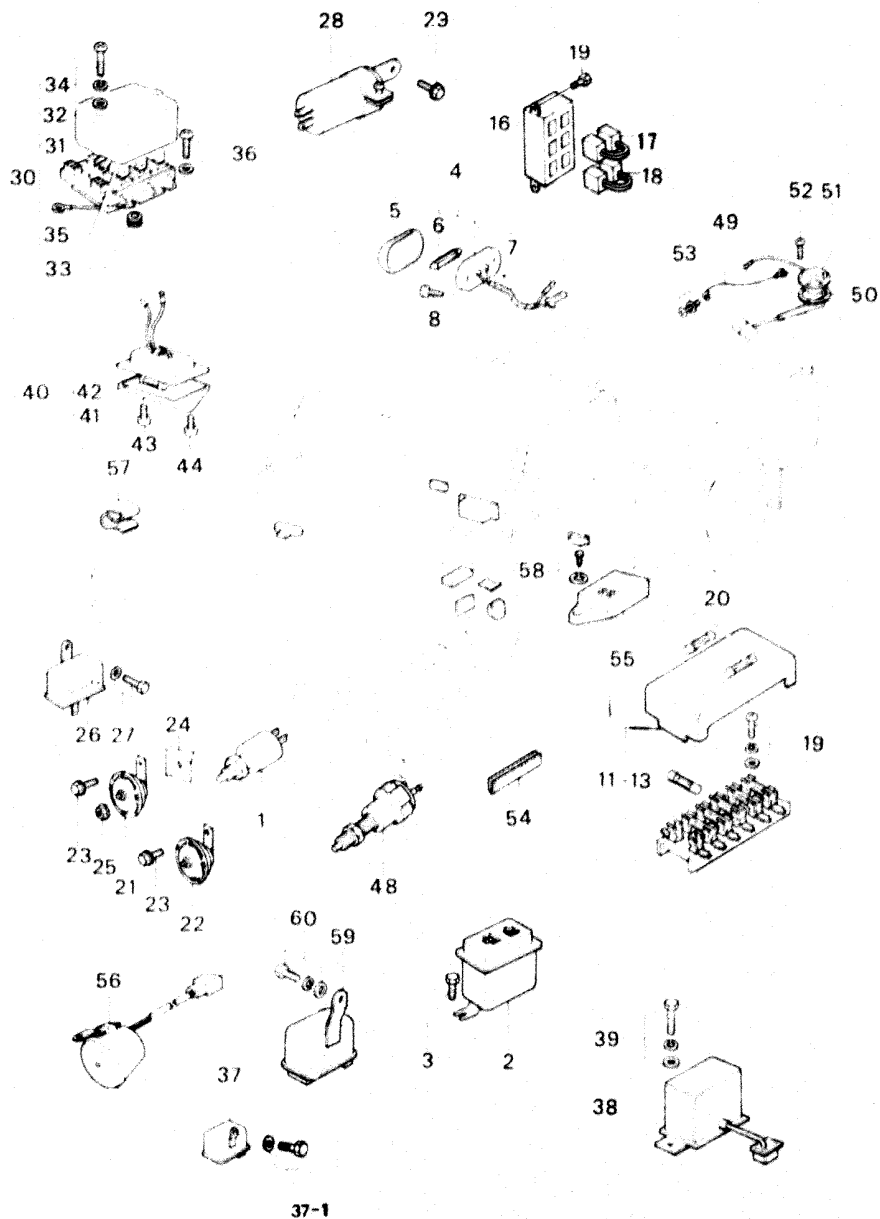

No. Part Number	Description	Qty	Remarks
13 99706 0115	Fuse (15A)	3	
99706 0110	Fuse (10A)	3	
14 3792 66 740	Bracket, Fuse Box	1	
15 99830 0512	Screw, Bracket	2	
16 8531 66 780	Block, Fuse	1	
17 3778 67 099	Link, Fusible	1	
18 3775 67 099	Link, Fusible	1	
19 99797 0516B	Bolt	2	
99952 0500	Washer, Plain	2	
20 1011 66 130	Spare Fuse Set	1	
21 1720 66 790B	Horn, Electric-Low Tone	1	
● 1720 66 790C	Horn, Electric-Low Tone	1	77/4 - Δ
22 1720 66 780B	Horn, Electric-High Tone	1	
● 1720 66 780C	Horn, Electric-High Tone	1	77/4 - Δ
23 99786 0816	Bolt, Electric Horn	2	

**ELECTRIC EQUIPMENT (BODY)
(SWITCH & RELAY)**

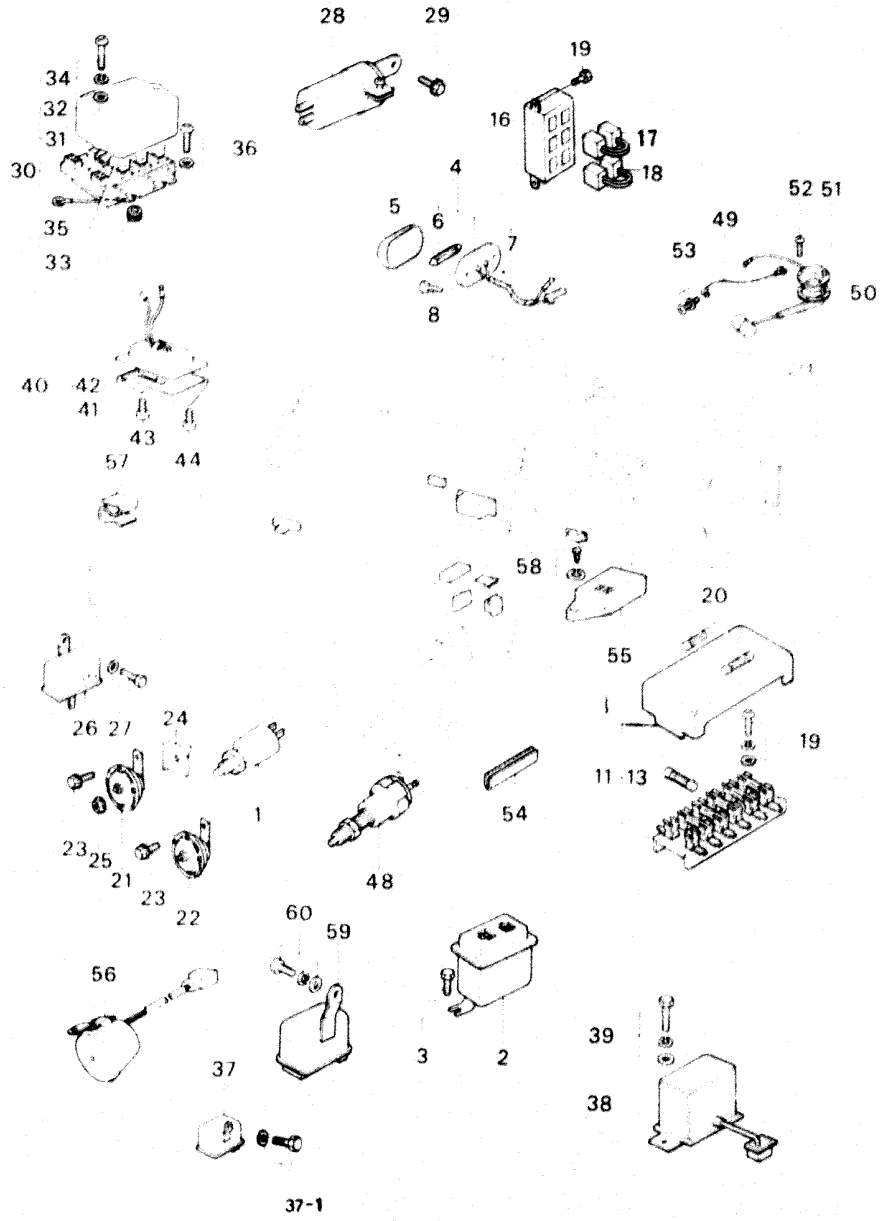

**ELECTRIC EQUIPMENT (BODY)
(SWITCH & RELAY)**

No.	Part Number	Description	Qty	Remarks
24	3996 66 771	Bracket, Horn	1	
25	99940 0900	Nut, Electric Horn	2	
26	1524 66 810	Relay, Horn	1	
27	99785 0612	Bolt	2	
	99952 0600	Washer, Plain	2	
28	3919 66 830	Unit, Flasher	1	
29	99940 0601	Nut, Flasher Unit	1	
	99953 0600	Washer, Plain	1	
30	1757 67 560	Unit, Central Control	1	
31	1757 67 562	Unit, Flasher	1	
32	1757 67 566	Cover	1	
33	0966 67 717	Gush	4	
34	0966 67 718	Screw	2	
	99952 0500B	Washer, Plain	2	
	99971 0500B	Washer, Spring	2	
35	0966 67 719	Relay	4	
36	99786 0630	Screw, Central Control Unit	3	
	99952 0600	Washer, Plain	3	
37	0839 67 880	Relay, Ignition	1	
37-1	99786 0616	Screw	1	
	99953 0600	Washer, Plain	1	

66

67

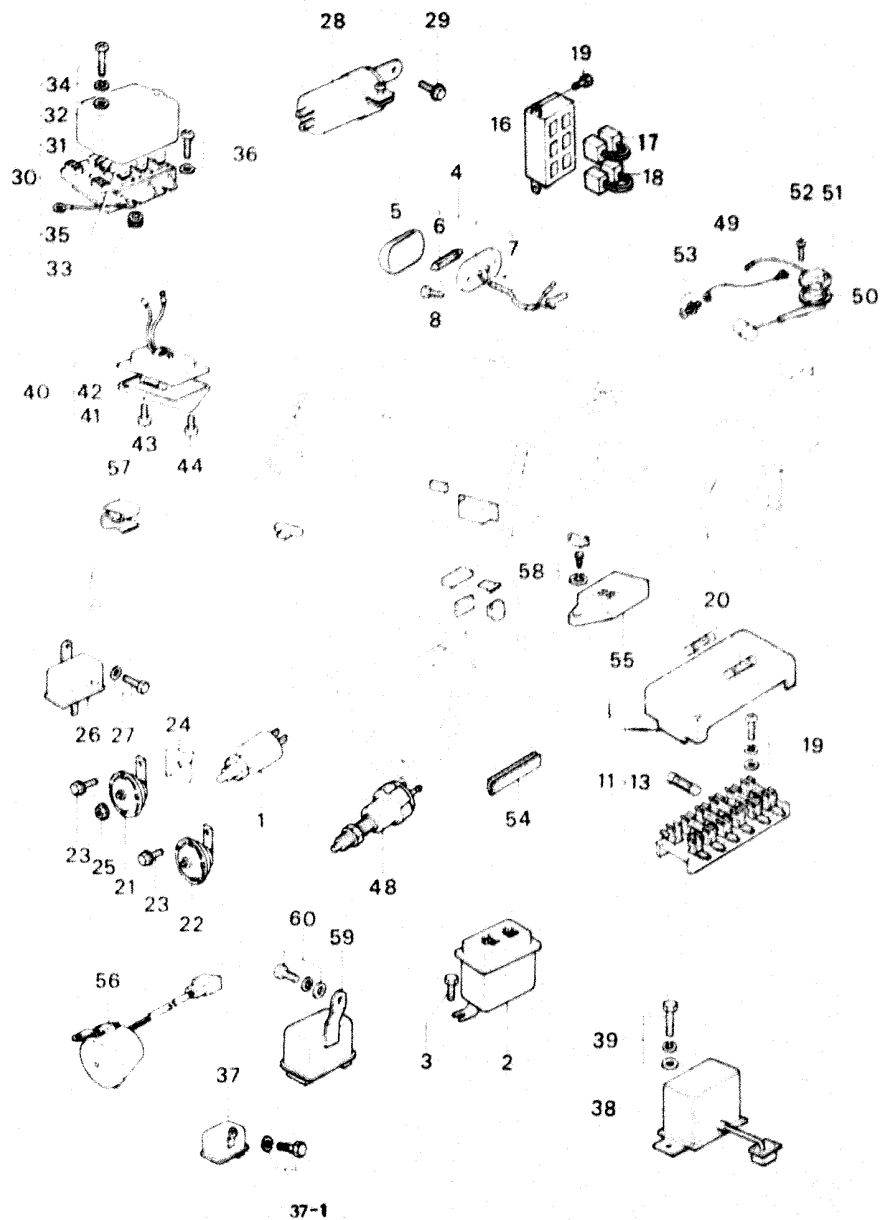
**ELECTRIC EQUIPMENT (BODY)
(SWITCH & RELAY)**

37-1

-233-

3-F10

66

67

**ELECTRIC EQUIPMENT (BODY)
(SWITCH & RELAY)**

No.	Part Number	Description	Qty	Remarks
38	0820 66 870A	Relay, Wiper	1	
		(Recipro)		
39	99786 0610	Belt, Wiper, Relay	2	
40	1650 66 620	Lamp, Warning	1	
41	1650 66 621	Lens	1	
42	99701 5050	Bulb	1	
43	99863 0310B	Screw	1	
44	99865 0412	Screw	2	
45	3776 67 090	Link, Fusible	1	
46	3776 67 765	Clip, Link	1	
47	09830 0516	Screw, Clip (Recipro)	1	
	09832 0520	Screw, Clip	1	
	09874 0600	Washer	1	(Rotary)
	09875 0500	Washer	1	
49	0233 66 790	Switch, Stop	1	
49	0189 66 795	Core, Earth (Recipro)	1	
• 50	3874 60 96?	Gasket (Nippon Denso Make)	1	
•	8531 60 962	Gasket (Yusin Make)	1	77/8 ~ Added Anew
•	8531 60 962A	Gasket (Yusin Make)	1	78/1 ~ Δ
51	1854 67 180A	Gauge, Fuel Tank	1	
•	1854 67 180B	Gauge, Fuel Tank	1	77/7 ~ Δ

AUG. 1978 Rotary Pick-up ('77)

-237-

Final Edition

66 **67** **ELECTRIC EQUIPMENT (BODY)**
(SWITCH & RELAY)

ELECTRIC EQUIPMENT (BODY)
(SWITCH & RELAY) **66** **67**

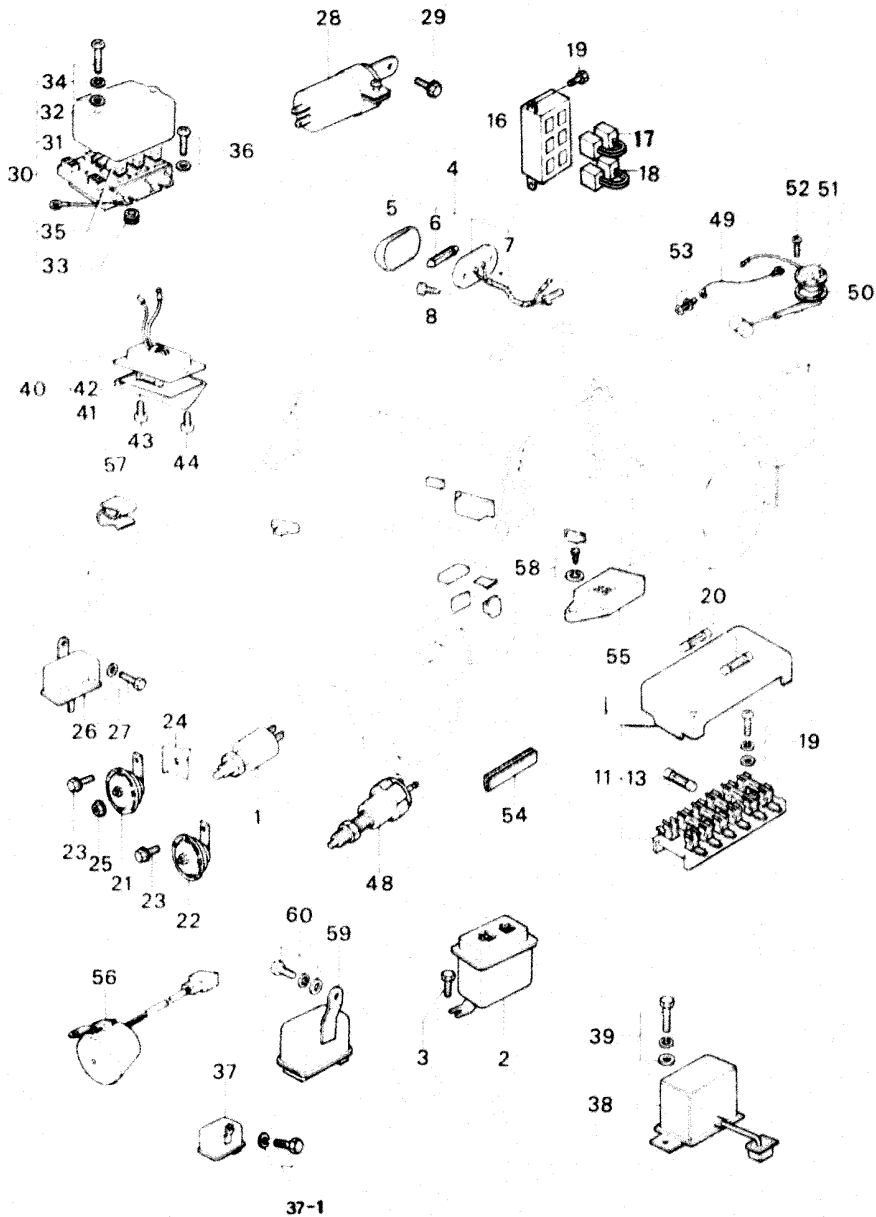

No.	Part Number	Description	Q'ty	Remarks
52	99833 0408	Screw Gauge	6	
53	99830 0500	Screw	1	(Recipro)
	99833 0410	Screw	1	
54	1011 42 901	Protector	1	
55	3564 67 700	Timer	1	
56	0735 67 730 A	Buzzer	1	
57	1011 67 923	Clip	5	
58	99786 0816	Screw	2	
	99953 0600	Washer, Plain	2	
59	1016 67 620	Relay Fast Idle	1	
60	99796 0610	Bolt Relay	1	

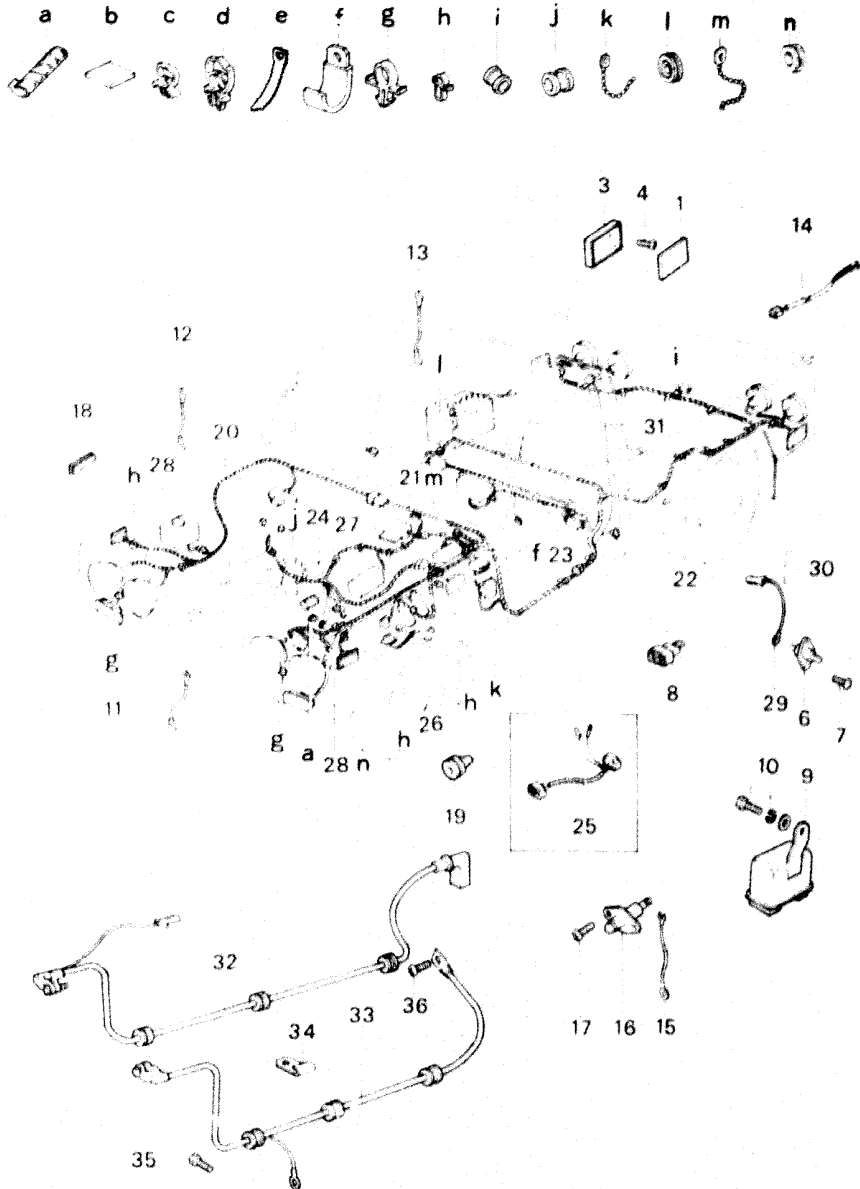

No.	Part Number	Description	Q'ty	Remarks
1	0419 51 571 A	Reflector, Reflex	2	
2	0527 66 651	Reflector, Reflex (Recipro)	2	
3	2627 66 601	Base, Reflex Reflector	2	
4	99865 0412	Screw, Reflex Reflector	4	
5	99940 0500	Nut, Reflex Reflector (Recipro)	2	
6	0305 60 690	Switch Door	2	
7	99864 0512	Screw, Door Switch	4	
8	1220 67 985 8715 67 985	Connector, Short (Federal) Connector, Short (Federal)	1 1	(Fed. Manual) 2 (Calif. Manual & Fed. Automatic) 3 (Calif. Automatic) 4 (California) 1
9	1220 67 740 3848 67 740	Relay 3P 2E Relay (3P)	2 2	(Fed. Manual) 2 (Calif. Manual) 4 (Calif. Automatic) 5 (Fed. Automatic) 3
10	99797 0616	Bolt, Relay	2	(Fed. Manual) 4 (Calif. Automatic) 5 (Fed. Automatic) 3
	99952 0600	Washer, Plain	2	(Fed. Manual) 4 (Calif. Manual) 5 (Fed. Automatic) 3
	99971 0600	Washer, Spring	2	(Fed. Manual) 4 (Calif. Manual) 5 (Fed. Automatic) 3
11	0553 67 143 A	Cord, Earth	1	
12	0710 66 868 A	Cord, Earth	1	
13	0603 66 723	Cord, Earth	1	
• 15	0188 66 731A	Cord	1	
16	0820 66 950	Switch	1	
17	99865 0408	Screw, Switch	2	
18	1907 67 151	Protector	1	

66 **67** **ELECTRIC EQUIPMENT
(HARNESS & CLIP)**

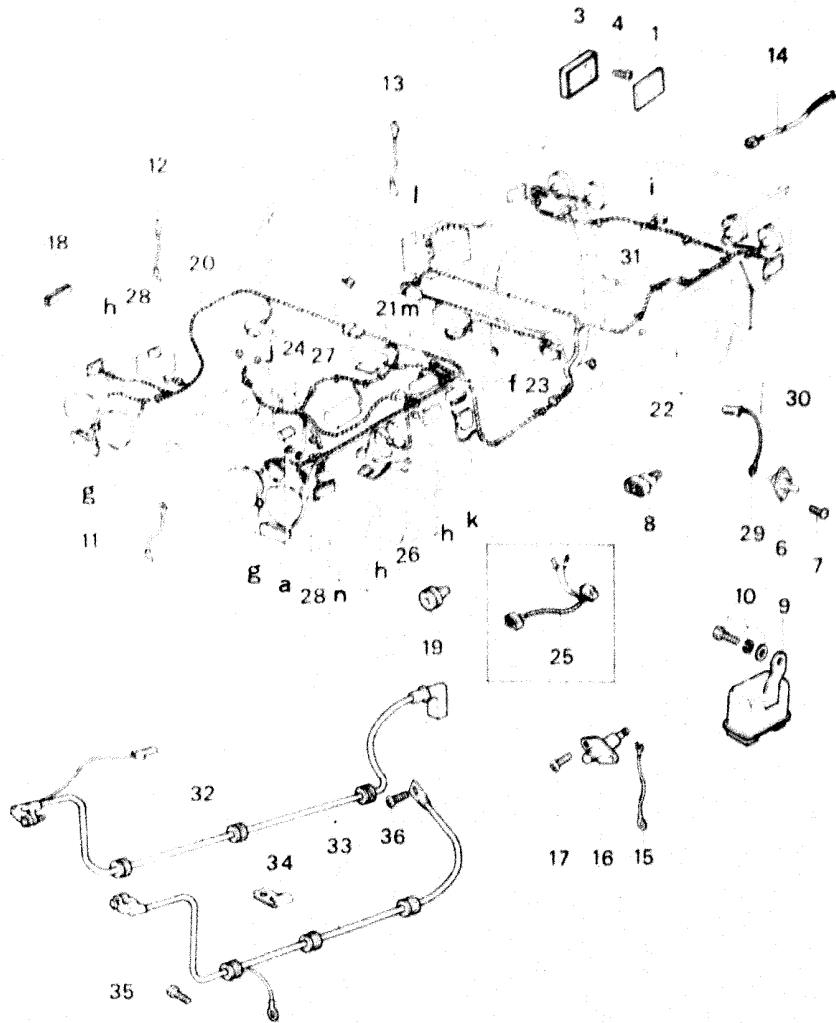
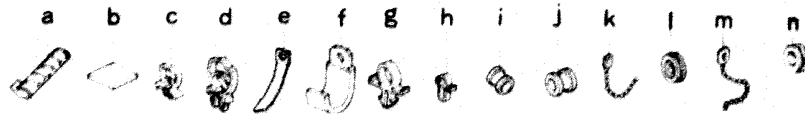

66 **67** **ELECTRIC EQUIPMENT (BODY)
(HARNESS & CLIP)**

No.	Part Number	Description	Qty	Remarks
19	0000 67 152	Protector (Recipro)	2	
20	3790 67 010 B	Harness (Frt.) Wire	1	
21	3775 67 020	Harness (Frt. L.) Wire	1	
22	3790 67 030 A	Harness (Rr.) Wire	1	
23	3790 67 040 A	Harness (Emission) Wire	1	
24	3790 67 060 A	Harness (Engine) Wire	1	
25	3791 67 070	Harness (Wire-Inhibitor) Automatic	1	
26	3775 67 080	Harness (Wire-Ig. Coil) (Rotary)	1	
27	1011 67 090	Harness (Wire-T. Mission) (Manual)	1	
28	1054 67 100	Harness (Wire-Head Lamp)	2	
29	0316 67 135	Cord (Door) Switch	2	
30	0301 67 157	Tape	2	
31	3906 67 240	Cord (Warning) Lamp	1	
32	2844 67 100 D	Cable (Battery Positive) (Recipro)	1	

**ELECTRIC EQUIPMENT
(HARNESS & CLIP)**

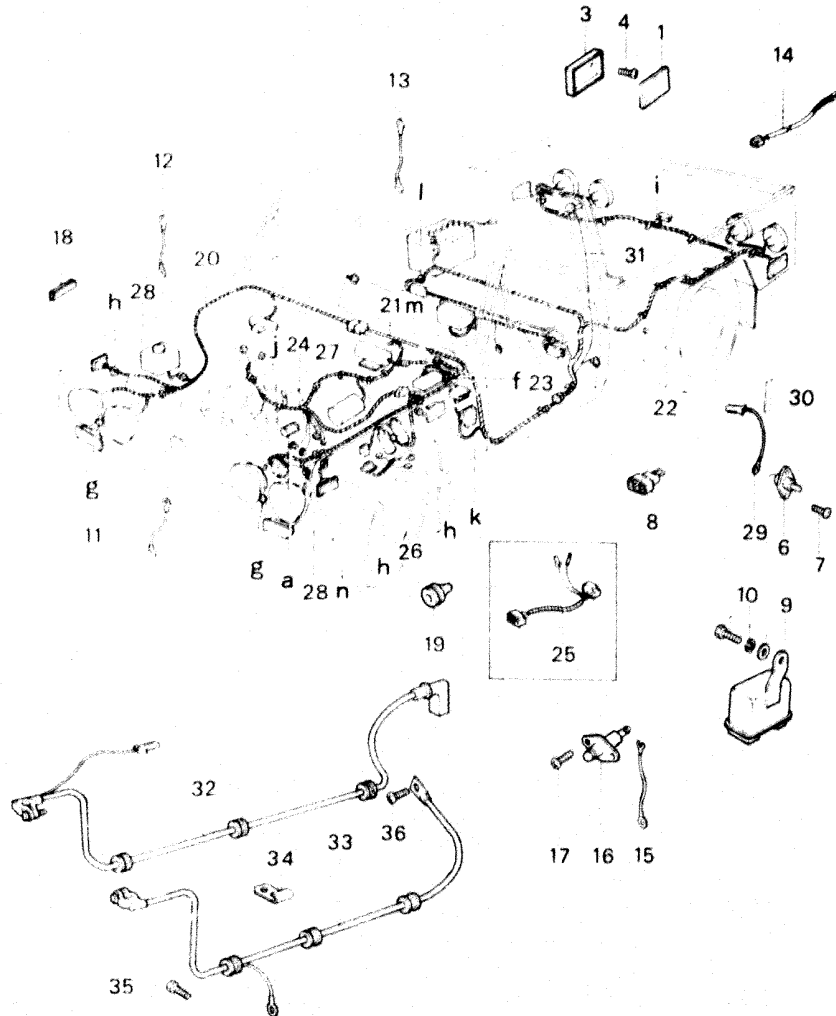
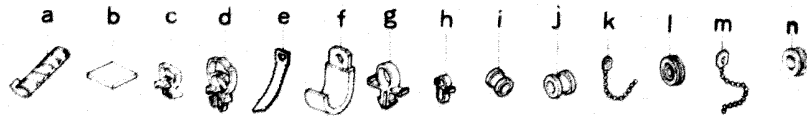

**ELECTRIC EQUIPMENT (BODY)
(HARNESS & CLIP)**

No.	Part Number	Description	Qty	Remarks
	379067 100A	Cable, Battery Positive	1	
33	379067 110	Wire, Earth-Battery	1	
	0223 66 722	Wire, Earth-Battery	1	
34	2844 67 991A	Clip	1	
35	99811 0816	Bolt, Earth Wire	1	Recipro.
	99852 0800	Washer, Plain	1	
	99971 0800	Washer, Spring	1	
36	99811 0816	Screw, Earth Wire (Rotary)	1	
	99788 0812	Bolt, Earth Wire	1	Recipro.
	99852 0800	Washer, Plain	1	
a	0923 18 111	Supporter, Engine Wire Harness	1	Recipro.
b	0305 67 994	Supporter, Engine Wire Harness	2	
b	0208 66 949	Pad, Protector	25	
c	1011 67 911	Clip, Wire Harness	7	
d	1011 67 912	Clip, Wire Harness	5	
e	0305 67 994	Supporter, Wire Harness	2	
f	1011 67 923	Clip, Wire Harness	1	
g	99279 0803	Clip, Wire Harness	2	
h	99270 1105	Clip, Wire Harness	1	
i	99684 1000	Protector, Cord	2	

66

67

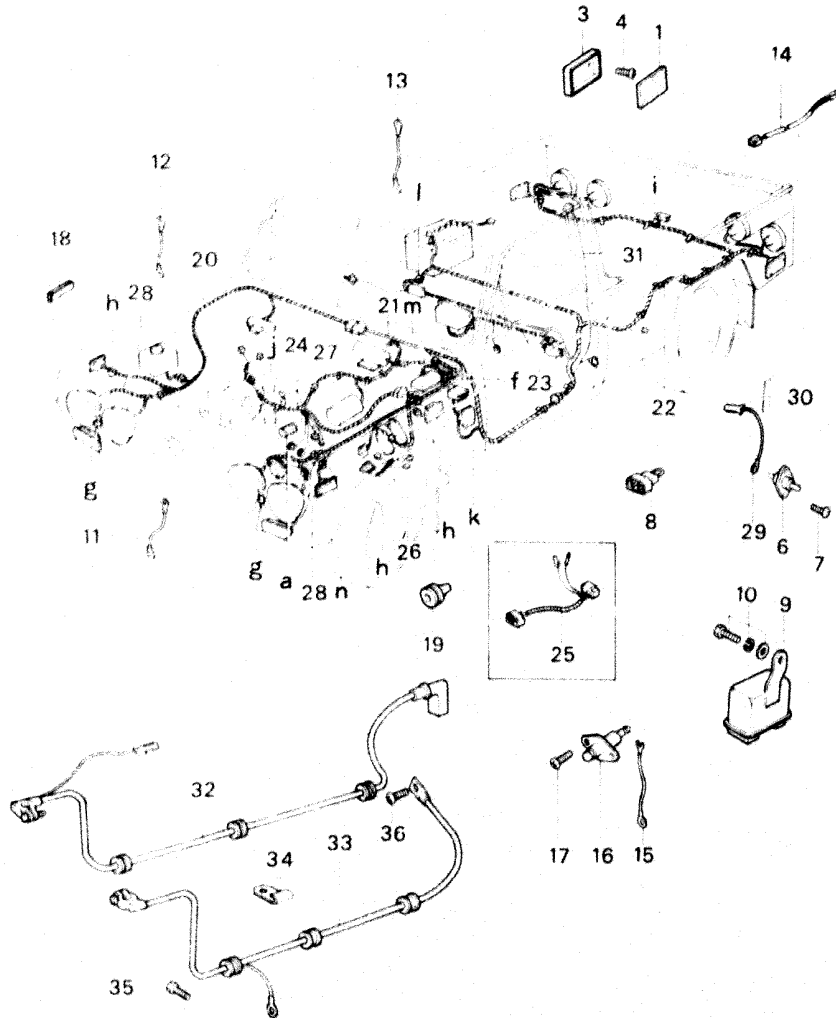
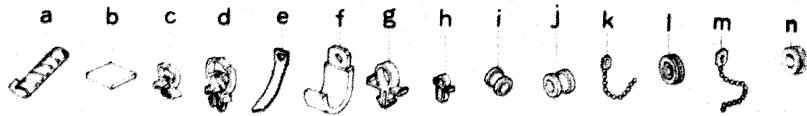
ELECTRIC EQUIPMENT
(HARNESS & CLIP)

66

67

ELECTRIC EQUIPMENT (BODY)
(HARNESS & CLIP)

No.	Part Number	Description	Qty	Remarks
j	99682 2001	Protector, Cord	2	
k	99709 3140	Band	7	
l	99686 2000	Protector	2	
m	99709 3250	Band	1	



No.	Part Number	Description	Qty	Remarks
1	0118 13 431	Washer, Rubber	2	
3	99794 0616	Bolt, Wiper	2	
	99953 0600	Washer, Plain	2	
	99971 0600	Washer, Spring	2	
4	2158 66 366 D	Arm, Wiper	2	
4-1	8532 76 641	Cover, Wiper Arm	2	
5	1823 67 350A	Motor & Link	1	
●	1823 67 350B	Motor & Link	1	77/6 ~ Δ
6	0212 66 371	Cap, Rubber	2	
●	7 0223 66 371	Nut	2	77/1 ~ Discarded
8	0212 66 372	Nut, Decoration	2	
9	1823 67 351	Bush	2	
10	1823 67 352	Bush	2	
11	1823 67 370 A	Motor, Wiper	1	
12	1823 67 380	Frame	1	
13	1823 67 390	Link, Wiper	1	
14	1823 76 602	Box, Gear	1	
15	0259 87 101A	Plate, Holder	1	
16	0259 87 103	Gasket	1	
17	2158 87 104	Plate, End	1	

66

87

WINDSHIELD WIPER

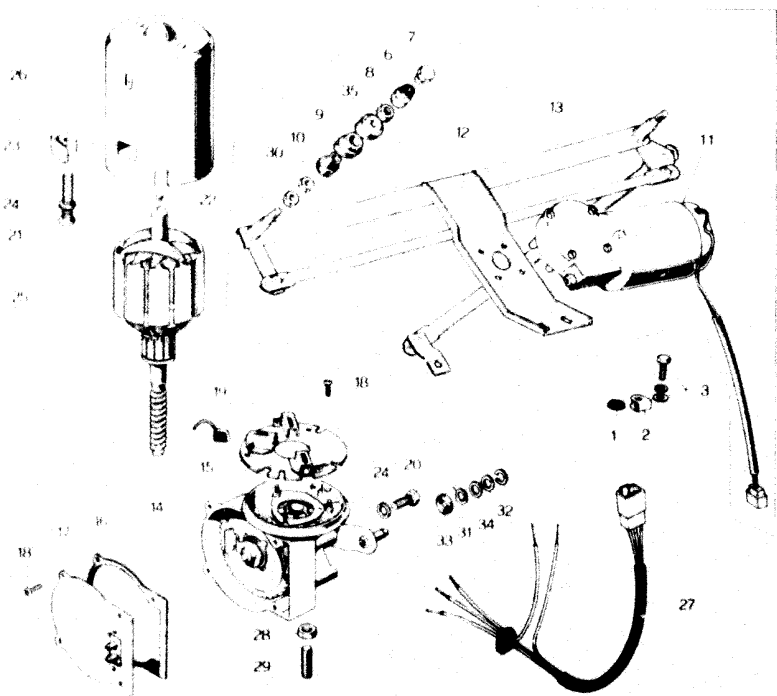
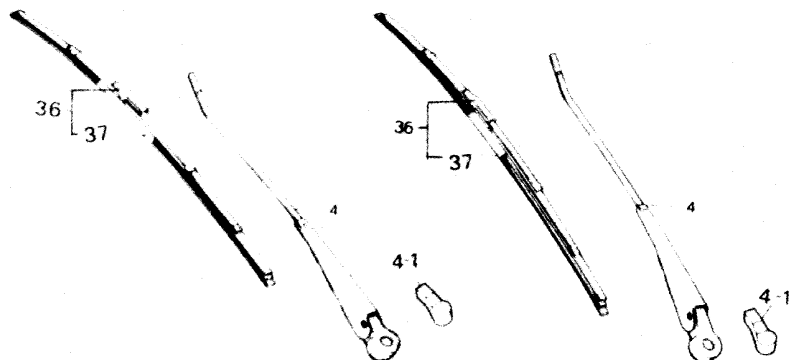

66

87

WINDSHIELD WIPER

No.	Part Number	Description	Q'ty	Remarks
18	0259 87 105	Screw	7	
19	0259 87 106	Brush	3	
20	99806 0510	Bolt	4	
21	0257 87 107	Screw	2	
22	0259 87 107	Ball	2	
23	0257 87 108	Nut	2	
24	99971 0500	Washer	6	
25	0259 87 108A	Rotor	1	
26	0259 87 109A	Starter	1	
27	2158 87 112B	Wire. Harness	1	
28	0259 87 119	Nut	1	
29	0259 87 120	Screw	1	
30	0259 87 134	Nut	4	
31	0702 87 135	Washer. Wave	1	
32	0702 87 138	Ring. Retaining	1	
33	0738 87 803	Felt	1	
34	0738 87 804	Washer	2	
35	0305 87 906	Washer. Cap	2	
36	1823 67 330	Blade. Wiper	2	
37	1823 76 631	Rubber, Wiper Blade	2	

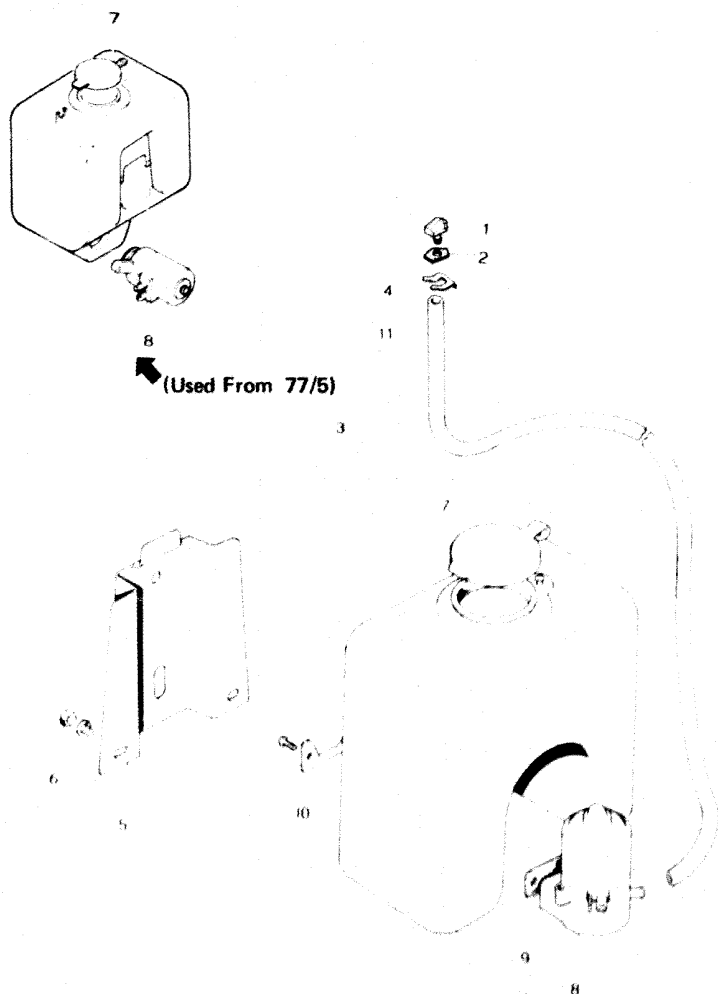

No.	Part Number	Description	Qty	Remarks
1	1011 67 510	Nozzle Washer	1	
2	1011 67 511A	Gasket	1	
3	0317 67 480	Tank	1	
•	0317 67 480A	Tank	1	77/5 ~ Δ
4	1011 67 515	Clip	1	
•	1011 67 515A	Clip	1	77/6 ~ ○
5	0866 67 521	Bracket	1	
6	99786 0612	Bolt Bracket	2	
7	0727 87 992	Cap	1	
•	1391 76 673	Cap	1	77/5 ~ Δ
8	0305 87 993	Pump	1	
•	8532 76 672	Pump	1	77/5 ~ Δ
•	9 0727 87 994	Gasket	1	77/5 ~ Discarded
•	10 0727 87 995	Plate	1	77/5 ~ Discarded
11	99335 04185	Proe	1	Ord. By 99335 04250

No.	Part Number	Description	Qty	Remarks
	1854 66 900	Tuner (AM)	1	
	1857 66 900	Tuner (AM FM)	1	
• 10	0395 87 084	Knob	2	
• 11	0398 66 965	Fuse	1	
12	1854 66 903	Bracket, Tuner	1	
13	1854 66 905	Panel, Decoration	1	
14	0866 66 960	Speaker, Loud	1	
15	0866 66 965	Cord, Loud Speaker	1	
16	0820 66 992	Condenser	2	
17	99709 0108	Band	1	
18	99940 0500	Nut	2	
19	99786 0510	Bolt, Bracket	2	

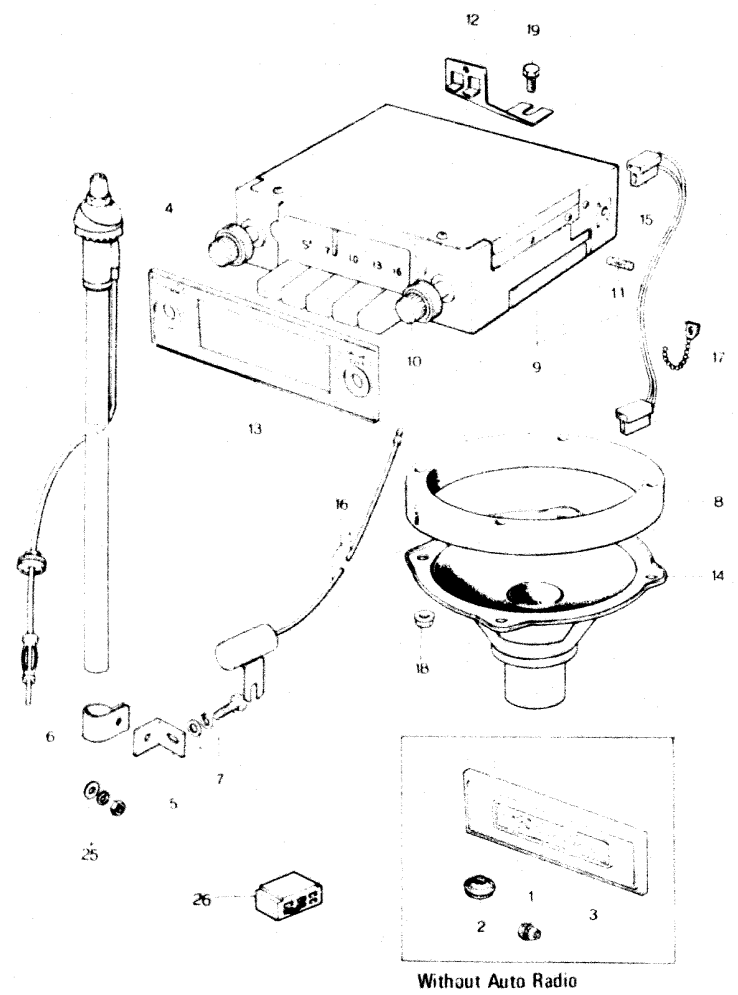

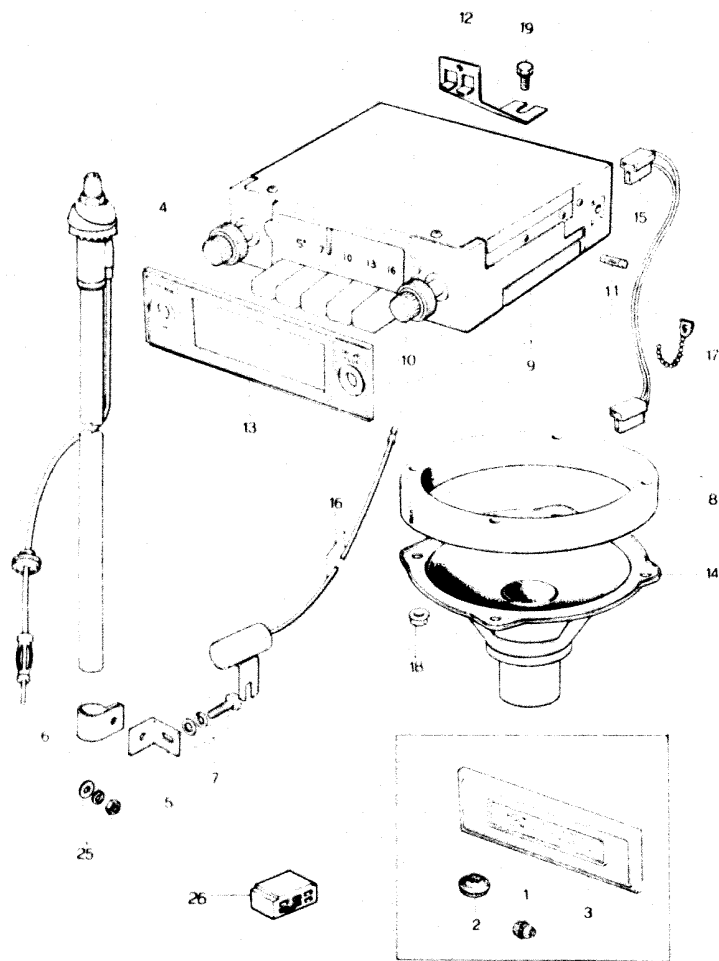

Without Auto Radio

No.	Part Number	Description	Qty	Remarks
	99971 0500	Washer, Spring (Recipro)	2	
	20 1820 66 873	Cord, Condenser (AM) (Recipro)	1	
	21 1820 66 871	Wire, Earth	1	
	22 1820 66 872	Tab, Earth	1	
	23 99796 0612	Bolt	1	
	99953 0600	Washer, Plain	1	
	99971 0600	Washer, Spring	1	
	24 99940 0600	Nut	1	
	25 99940 0500	Nut, Clip (Rotary)	1	
	99906 0500	Nut	1	
	99957 0500	Washer, Plain (Recipro)	1	
	99971 0500	Washer, Spring	1	
26	1010 66 980	Cord, Short	1	

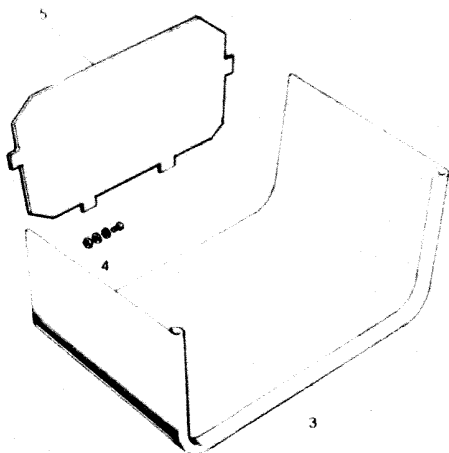
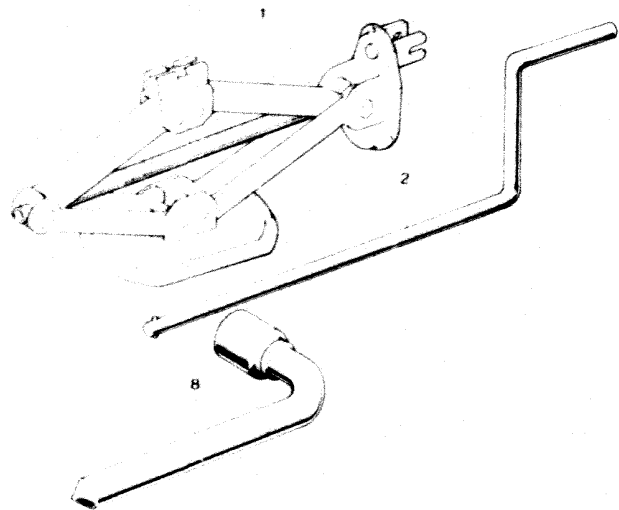

No.	Part Number	Description	Q'ty	Remarks
1	1854 37 790A	Jack, Pantograph	1	
2	0603 68 240	Lever, Jack Crank	1	
3	3792 68 610B	Shelf, Parcel	1	
4	99834 0512	Screw, Parcel Shelf	4	
	99971 0500	Washer, Spring	4	
	99952 0500	Washer, Plain	8	
	99906 0500	Nut	4	
5	3792 68 615	Plate, End-Parcel Shelf	1	
	1819 68 660	Tools (Recipro)	1	
	1854 68 660	Tools (Rotary)	1	
6	0866 68 680	Wrench, Monkey (Recipro)	1	
	0110 68 050A	Wrench, Monkey (Rotary)	1	
7	0672 68 060A	Spanner, Set	1	
8	0810 68 070A	Wrench, Hub Nut	1	
9	0187 68 110A	Screw Driver, Set	1	
10	2677 68 110	Screw Driver, Set	1	
11	0672 68 120A	Screw Driver, Set	1	
12	0118 68 180A	Plier	1	
13	1819 68 670	Bag, Tool (Recipro)	1	

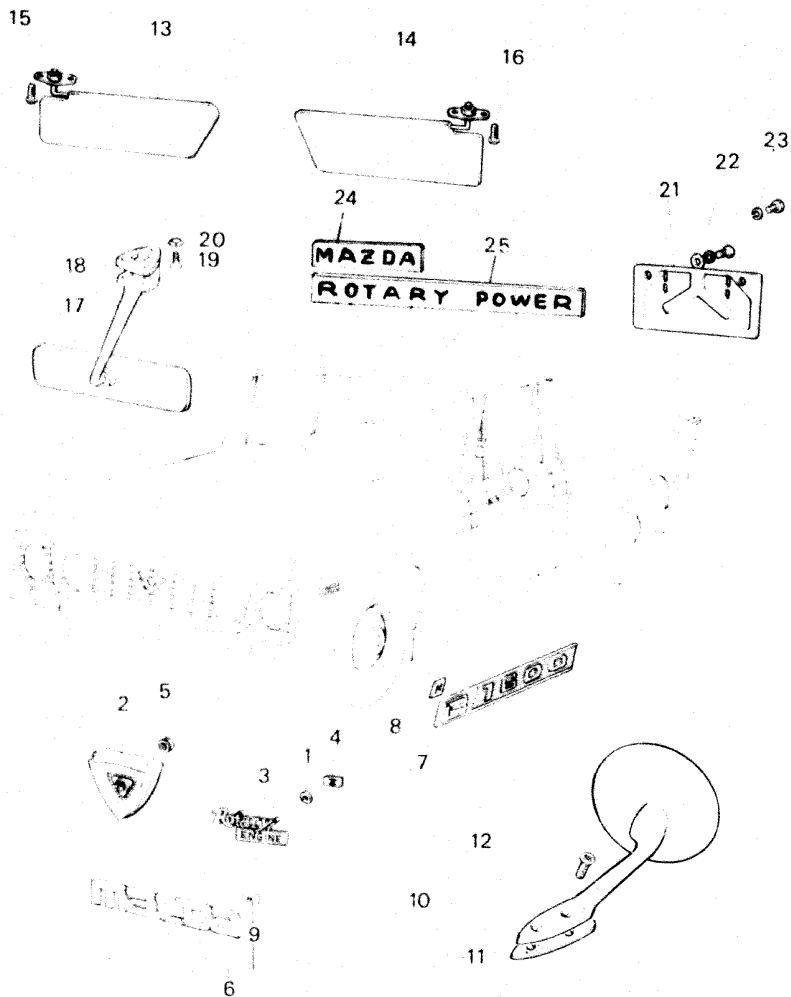

No.	Part Number	Description	Q'ty	Remarks
1	0730 69 057A	Gasket	2	
2	1128 69 071A02	Emblem, Front (SILV M)	1	
3	1881 69 076	Mark, Rotary Engine	1	
4	99578 3000	Nut, Speed	2	
5	99940 0500	Nut, Front Emblem	1	
6	0587 89 804	Ornament, Front	1	
7	2877 69 053A	Name, Side (1800 cc)	2	
	2844 69 053A	Name, Side (1600 cc) (Recipro)	2	
8	99579 3000	Nut, Speed-Side Name	4	
9	0187 69 049A	Nut, Speed	2	
10	2850 69 090	Mirror, Rear View	1	
11	2850 69 101	Gasket	1	
12	99772 0516	Screw	2	
13	1823 69 150B31	Sun Visor (R) (BEIG)	1	
14	1823 69 170B31	Sun Visor (L) (BEIG)	1	
15	99764 0416	Screw, Tapping-Sun Visor	2	
16	99764 0416	Screw, Tapping-Sun Visor	2	
17	0222 69 190A	Mirror, Interior	1	

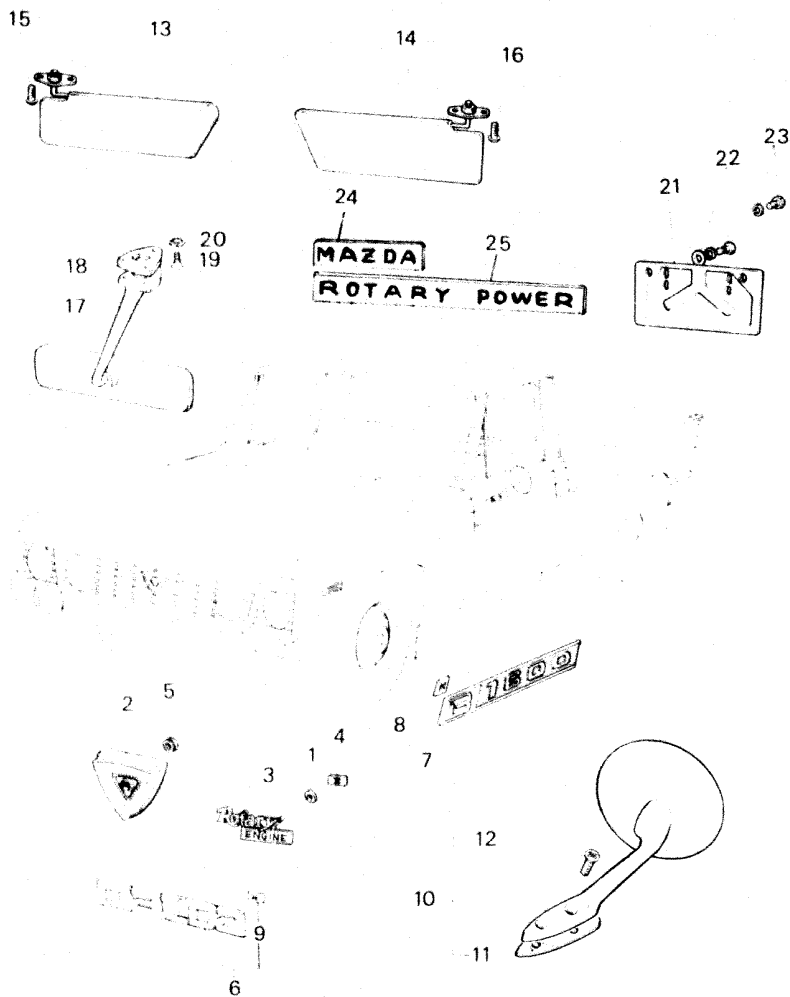

No.	Part Number	Description	Q'ty	Remarks
● 18	0223 69 181	Base, Interior Mirror	1	
19	99831 0416	Screw, Interior Mirror	3	
20	99975 0400	Washer	3	
21	2651 69 810	Holder, Number Plate	1	
22	99806 0616	Bolt, Number Plate Holder	2	
	99971 0600	Washer, Spring	2	
23	99806 0612	Bolt, Number Plate Holder	2	
	99971 0600	Washer, Spring	2	
24	1854 69 088	Label, MAZDA	1	
25	1854 69 087A-00	Label, ROTARY POWER (WHITE)	1	
	1854 69 087A-02	Label, ROTARY POWER (BLUE)	1	

No.	Part Number	Description	Q'ty	Remarks
1	3874 69 310 31	Ceiling, Top (BEIG)	1	
2	3790 69 321	Plate (R), Fixing	1	
3	3790 69 322	Plate (L), Fixing	1	
4	99862 0410	Screw, Tapping-Fixing Plate	6	
5	99863 0512	Screw, Tapping	3	
	99952 0500	Washer, Plain	3	
	99971 0500	Washer, Spring	3	
6	0603 69 323A	Cushion, Listing	1	
7	1854 69 411	Trim (R), Pillar	1	
8	1854 69 412	Trim (L), Pillar	1	
9	1854 69 461B	Trim (R), Rear Pillar	1	
10	1854 69 471B	Trim (L), Rear Pillar	1	
11	99867 0516B	Screw	6	
	99967 0500B	Washer	6	
12	3792 69 511A06	Trim (R), Cowl Side (BLK)	1	
13	3792 69 521B06	Trim (L), Cowl Side (BLK)	1	
14	99862 0416B	Screw, Tapping	10	
	99968 0400B	Washer	10	

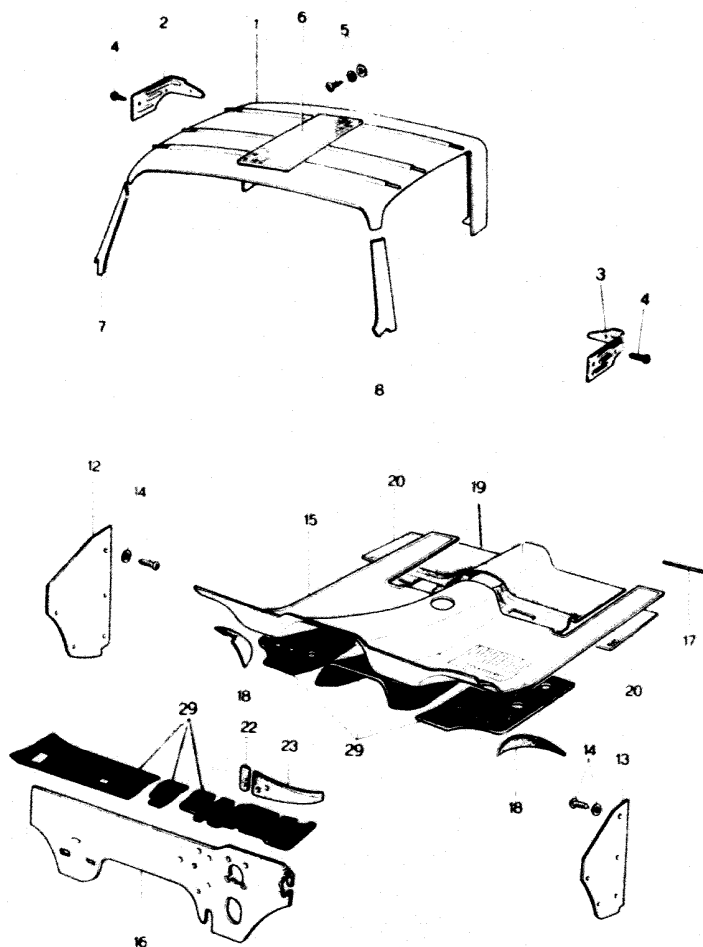

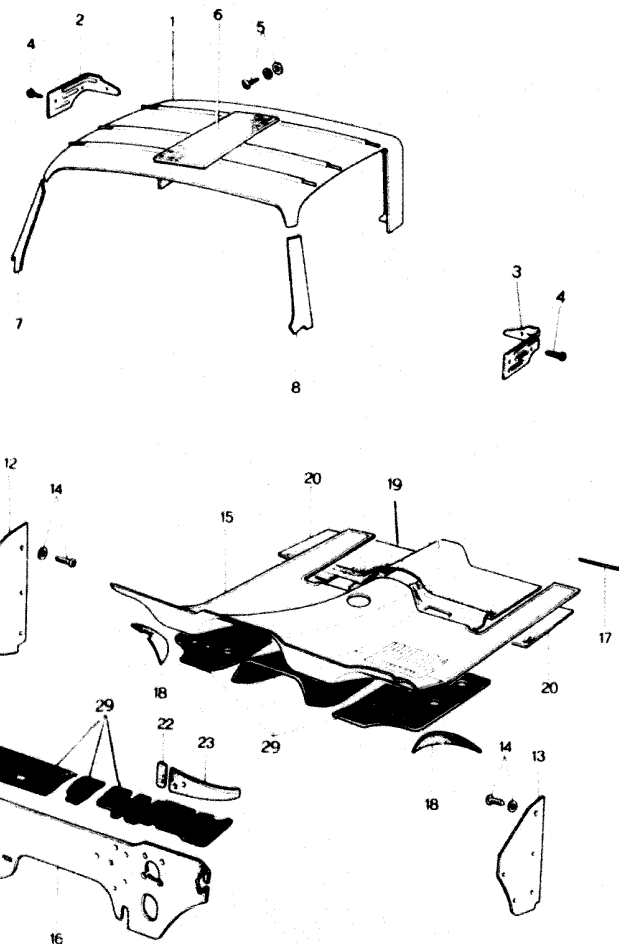

No.	Part Number	Description	Qty	Remarks
-----	-------------	-------------	-----	---------

When ordering the following Mat.
add colour code nos. given below after parts number.
-00 (BLK) -20 (BRN) -50 (BLU)

15	1854 69 611 A C	Mat. Floor (Manual)	1	
	1856 69 611 A C	Mat. Floor (Automatic)	1	
16	1854 69 660 B	Insulation	1	
17	0727 69 662	Wire, No. 2	4	
18	1854 69 683	Pad, Tire House	2	
19	1854 69 684 B	Pad, Seat Lower	1	
20	1854 69 685	Pad, Floor - Seat Side	2	
22	1854 69 688	Pad, Dashboard No 3	1	
23	1854 69 689 A	Pad, Dashboard No 4	1	
24	1854 69 691 B	Pad, Seat Lower Rear	1	
25	1854 69 692 D	Pad, Back Plate	1	
26	0603 69 637 C	Pad, Floor Side	2	
27	2495 69 681 A	Pad, Floor Center (Recipro)	1	
28	0167 69 691	Rubber	6	
29	0208 76 071	Silencer (A 30cm square sheet)	-	

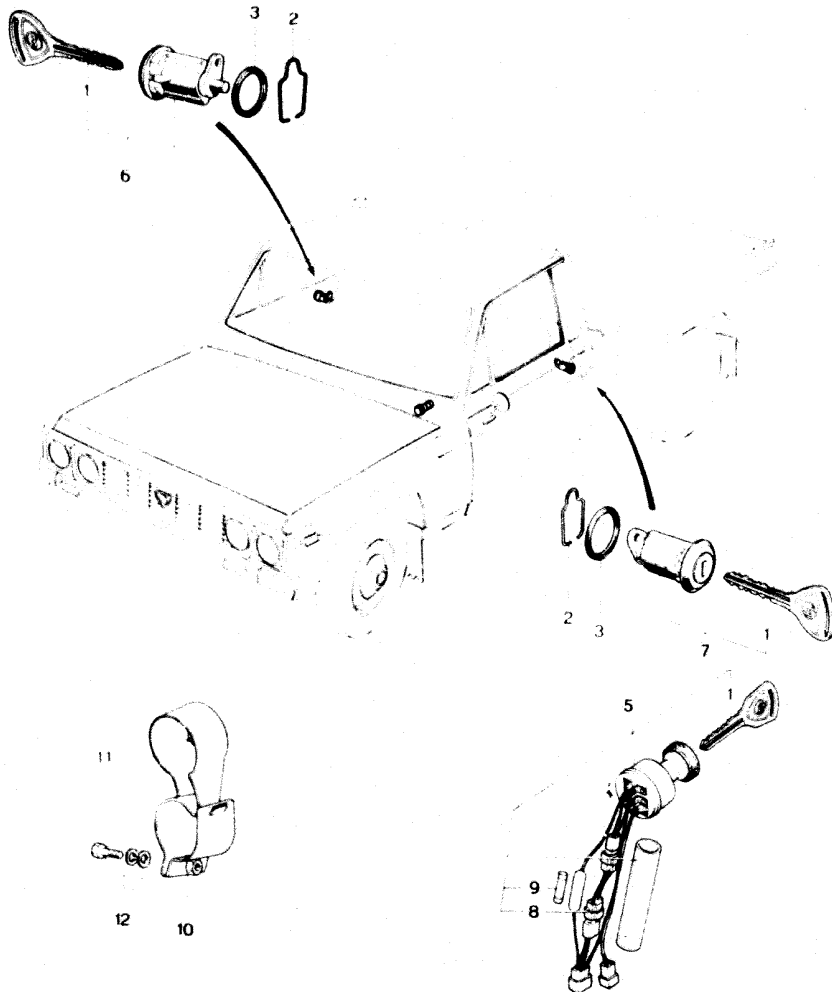

No.	Part Number	Description	Q'ty	Remarks
	3775 09 010 B	Key Set	1	
● 1	2119 58 668	Key	2	Discarded
2	0223 58 961	Fastener, Key Cylinder	2	
3	0223 58 962	Gasket, Door Key Cylinder	2	
4	3917 75 980	Key Sub Set, Ignition Switch (Recipro)	1	
5	3775 75 980	Key Sub Set, Ignition Switch	1	
6	1819 75 910	Key Sub Set (R), Door	1	
7	1819 75 920	Key Sub Set (L), Door	1	
8	1175 66 710	Link, Fusible	1	
●	1175 66 710A	Link, Fusible	1	77/9 - Δ
9	99706 0110	Fuse (10A)	1	
10	0370 60 425A	Bracket, Ignition Switch	1	
11	0370 60 500B	Bracket, Ignition Switch	1	
12	99273 0620	Bolt, Bracket	1	
	99952 0600	Washer, Plain	1	
	99971 0600	Washer, Spring	1	
●	2119 74 158	Key Blank (5000 - 6099)	1	

PARTS NUMBER	PARTS COMP. LIST PAGE	FIG. NO.	FICHE INDEX	PARTS NUMBER	PARTS COMP. LIST PAGE	FIG. NO.	FICHE INDEX
3775 09 010B	262		3-H13	1757 10 600B	004	045	1-E1
3775 10 100	002	001	1-C1	0820 10 605	004	046	1-E1
0839 10 105	002	002	1-C1	1757 10 609	004	047	1-E1
1757 10 111	002	006	1-C1	0820 10 631B	004	048	1-E1
1757 10 120	002	003	1-C1	8527 10 641	005	060	1-F1
1757 10 171A	002	007	1-C1	8527 10 641	008	085	1-I1
1757 10 171A	007	085	1-H1	1757 10 711	008	085	1-I1
1757 10 172	002	008	1-C1	3565 10 730A	007	080	1-H1
1757 10 172	007	085	1-H1	3565 10 830	006	069	1-G1
0813 10 173	002	009	1-C1	1757 10 845	006	070	1-G1
0813 10 173	008	085	1-I1	3565 10 860B	006	071	1-G1
8527 10 174	002	010	1-C1	1757 10 862	006	074	1-G1
8527 10 174	008	085	1-I1	3565 10 865B	006	072	1-G1
3646 10 200	002	011	1-C1	0820 10 872A	158	025	2-H9
0820 10 203	003	027	1-D1	1011 11 111	013	051	1-M1
0839 10 203	002	012	1-C1	1202 11 300A	010	009	1-J1
2329 10 204	002	013	1-C1	1202 11 302	010	010	1-J1
0839 10 205	002	014	1-C1	1757 11 304	010	011	1-J1
0839 10 205	003	028	1-D1	1056 11 307A	010	009	1-J1
1757 10 206A	002	015	1-C1	0820 11 317	010	012	1-J1
1757 10 207	002	016	1-C1	1202 11 321	010	013	1-J1
1757 10 208	003	020	1-D1	1202 11 323	010	014	1-J1
0324 10 250	003	024	1-D1	0820 11 341	008	085	1-I1
0453 10 250	003	024	1-D1	0820 11 341	010	015	1-J1
0324 10 252	003	025	1-D1	1202 11 343	008	085	1-I1
1029 10 305	004	037	1-E1	1202 11 343	010	016	1-J1
1757 10 305	004	040	1-E1	1011 11 351	011	017	1-K1
1757 10 309	003	029	1-D1	1011 11 353A	011	018	1-K1
0866 10 320A	003	050	1-D1	1011 11 361	011	019	1-K1
1757 10 351	004	041	1-E1	1011 11 363A	011	020	1-K1
3565 10 410A	007	076	1-H1	3648 11 400	011	021	1-K1
2329 10 417	007	077	1-H1	8501 11 400	011	021	1-K1
1757 10 451	004	043	1-E1	1881 11 403	011	022	1-K1
1757 10 452	004	043	1-E1	1881 11 404	011	023	1-K1
0839 10 455	004	044	1-E1	0813 11 405	011	024	1-K1
0839 10 455	008	085	1-I1	0839 11 411A	011	026	1-K1
2306 10 481	032	040	1-E4	0839 11 412	011	027	1-K1
3648 10 500	010	001	1-J1	1011 11 501	011	029	1-K1
0820 10 502B	010	002	1-J1	0839 11 502	011	031	1-K1
0820 10 502B	010	005	1-J1	1011 11 504	012	032	1-L1
0839 10 504	010	003	1-J1	0813 11 505B	012	033	1-L1
3648 10 550	010	004	1-J1	0839 11 506	011	031	1-K1
0813 10 555	008	085	1-I1	1011 11 507	012	034	1-L1
0813 10 555	010	008	1-J1	0839 11 508	012	031	1-L1
1668 10 555	010	006	1-J1	0839 11 509	012	031	1-L1

PARTS NUMBER	PARTS COMP. LIST PAGE	FIG. NO.	FICHE INDEX	PARTS NUMBER	PARTS COMP. LIST PAGE	FIG. NO.	FICHE INDEX
1757 11 511	012	035	1-L1	0866 13 402B	034	005	1-F4
1854 11 511	012	035	1-L1	0118 13 431	245	001	3-C11
0839 11 531	012	037	1-L1	1757 13 445	034	005	1-F4
0839 11 551A	012	038	1-L1	8503 13 446A	034	007	1-F4
3790 11 600	012	039	1-L1	1570 13 447	034	008	1-F4
0820 11 611B	012	040	1-L1	8527 13 447	034	009	1-F4
1854 11 700	012	042	1-L1	1883 13 448	034	010	1-F4
0866 11 702	012	043	1-L1	1757 13 449	034	012	1-F4
0820 11 705	012	045	1-L1	8527 13 449	035	035	1-G4
0810 11 711	013	046	1-M1	8527 13 459	035	035	1-G4
0820 11 712	013	047	1-M1	0222 13 470B	035	019	1-G4
1029 11 750	015	048	1-M1	0381 13 481	035	020	1-G4
3565 13 1000	015	001	1-C2	1757 13 510B	022	001	1-G2
1010 13 104	032	041	1-E4	1881 13 515A	022	002	1-G2
8712 13 104	032	042	1-E4	1757 13 527B	022	004	1-G2
1757 13 111A	008	085	1-I1	8712 13 531	022	005	1-G2
1757 13 111A	015	009	1-C2	0839 13 614	016	019	1-D2
3787 13 200	024	001	1-C3	1757 13 710A	030	001	1-C4
3789 13 200	024	001	1-C3	1757 13 714	030	004	1-C4
1757 13 201A	027	065	1-F3	1757 13 715	030	007	1-C4
8527 13 205	027	068	1-F3	0136 13 717A	024	002	1-C3
8712 13 220A	027	066	1-F3	1757 13 717	030	008	1-C4
1757 13 221A	006	085	1-I1	3565 13 718	030	009	1-C4
1757 13 221A	027	066	1-F3	8712 13 720	030	010	1-C4
8712 13 231A	027	069	1-F3	3565 13 724	008	085	1-I1
3597 13 240	018	001	1-E2	3790 13 724	030	012	1-C4
3597 13 240A	018	001	1-E2	3648 13 725	031	025	1-D4
8735 13 240	018	009	1-E2	2329 13 726	030	013	1-C4
8735 13 240A	018	009	1-E2	3790 13 730	030	014	1-C4
3648 13 270	035	034	1-G4	8501 13 740	030	015	1-C4
3648 13 290	016	006	1-E2	2090 13 742B	016	017	1-D2
8501 13 2950	016	002	1-E2	1757 13 744	030	017	1-C4
3648 13 300B	020	001	1-F2	2090 13 746	031	018	1-D4
1617 13 305A	020	007	1-F2	1757 13 750	031	019	1-D4
3648 13 310A	020	008	1-F2	8715 13 750	031	019	1-D4
3565 13 330A	015	011	1-C2	8712 13 752	031	022	1-D4
2850 13 331	076	001	1-C9	1757 13 753C	031	023	1-D4
1757 13 341A	015	013	1-C2	8735 13 754	031	024	1-D4
1757 13 351A	020	002	1-F2	8712 13 757	031	026	1-D4
0223 13 363	034	001	1-F4	3648 13 759	031	021	1-D4
1757 13 371B	015	014	1-C2	3790 13 759A	031	021	1-D4
3565 13 380B	016	022	1-D2	8735 13 772B	031	030	1-D4
3565 13 390	016	023	1-D2	1757 13 780	035	022	1-G4
1854 13 400A	034	002	1-F4	3565 13 785	035	024	1-G4
1854 13 400B	034	002	1-F4	1757 13 786B	035	025	1-G4

PARTS NUMBER		PARTS COMP. LIST PAGE	FIG. NO.	FICHE INDEX	PARTS NUMBER		PARTS COMP. LIST PAGE	FIG. NO.	FICHE INDEX
0114	13 768A	024	003	1-C3	1757	14 740	042	010	1-C6
3565	13 768A	035	026	1-G4	1758	14 740	042	010	1-C6
1757	13 790	035	028	1-G4	0839	14 745	042	011	1-C6
1757	13 790A	033	028	1-G4	1757	14 810	042	003	1-C6
1854	13 792A	035	029	1-G4	1757	14 821	042	004	1-C6
3565	13 795	035	030	1-G4	1757	14 822	042	005	1-C6
3567	13 800A	016	016	1-D2	1757	14 823	042	006	1-C6
3597	13 863	018	007	1-E2	8527	15 010	043	018	1-D6
2329	13 875	016	018	1-D2	8527	15 010A	043	018	1-D6
2329	13 882	016	019	1-D2	8553	15 010B	043	018	1-D6
1757	13 889B	008	085	1-I1	2090	15 104	043	019	1-D6
1757	13 889B	016	020	1-D2	1757	15 105A	008	085	1-I1
1757	13 891	008	085	1-I1	1757	15 105A	044	035	1-E6
1757	13 891	016	021	1-D2	1757	15 106	008	085	1-I1
8501	14 100	037	008	1-C5	1757	15 106	044	036	1-E6
8501	14 110	037	014	1-C5	1757	15 114	043	020	1-D6
1757	14 112	037	009	1-C5	1757	15 118	043	021	1-D6
0810	14 113	037	010	1-C5	1757	15 120	043	022	1-D6
0839	14 115	004	049	1-E1	3648	15 130	043	028	1-D6
0839	14 117	037	011	1-C5	3648	15 130A	043	028	1-D6
8501	14 118	037	012	1-C5	3648	15 130B	043	028	1-D6
0839	14 119B	037	013	1-C5	1757	15 132	043	023	1-D6
0839	14 141A	036	016	1-D5	1757	15 151B	044	038	1-E6
0839	14 142	036	017	1-D5	1757	15 152A	043	024	1-D6
0866	14 160E	036	016	1-D5	1757	15 152B	043	024	1-D6
0810	14 171	038	019	1-D5	0839	15 171A	043	025	1-D6
3648	14 250	036	021	1-D5	8553	15 171	043	025	1-D6
0839	14 273A	004	050	1-E1	8519	15 172	043	026	1-D6
0839	14 274	004	051	1-E1	1757	15 173	043	027	1-D6
1757	14 600	038	028	1-D5	3648	15 200	044	042	1-E6
1757	14 611	039	038	1-E5	0766	15 205	045	047	1-F6
0820	14 620A	039	040	1-E5	1202	15 210	045	043	1-F6
0813	14 623	039	041	1-E5	1907	15 211	044	040	1-E6
0820	14 625A	039	042	1-E5	1907	15 211A	044	040	1-E6
0813	14 641	039	043	1-E5	3648	15 250	044	041	1-E6
1757	14 651	039	044	1-E5	1854	15 310D	045	046	1-F6
1757	14 652	040	048	1-F5	1856	15 310E	045	046	1-F6
1757	14 653	040	048	1-F5	1715	15 312	042	001	1-C6
3565	14 660A	040	049	1-F5	1854	15 312	045	049	1-F6
3565	14 662A	044	034	1-E6	3565	15 350B	045	052	1-F6
3565	14 670A	040	050	1-F5	1854	15 351C	046	055	1-G6
1854	14 700	042	002	1-C6	3565	15 370	045	053	1-F6
0813	14 715	042	007	1-C6	3900	15 411	046	056	1-G6
0865	14 720	042	008	1-C6	3900	15 421	046	057	1-G6
1570	14 730A	042	009	1-C6	1854	15 511	046	061	1-G6

			PARTS COMP. LIST							PARTS COMP. LIST			
PARTS NUMBER			PAGE	FIG. NO.	FICHE INDEX	PARTS NUMBER			PAGE	FIG. NO.	FICHE INDEX		
1854	15	521	046	062	1-G6	0839	17	287	056	027	1-G7		
0603	16	102B	048	001	1-H6	0839	17	288	056	027	1-G7		
0603	16	103	048	005	1-H6	0821	17	297	056	028	1-G7		
0222	16	103	048	006	1-H6	0862	17	301A	056	029	1-G7		
0813	16	112	048	003	1-H6	0821	17	302	056	030	1-G7		
1861	16	210B	048	004	1-H6	3648	17	302	056	030	1-G7		
0866	16	214A	048	007	1-H6	0821	17	303	056	031	1-G7		
0222	16	222	048	012	1-H6	0884	17	304	056	032	1-G7		
0895	16	410	048	008	1-H6	0839	17	305	056	033	1-G7		
0839	16	432	048	009	1-H6	0839	17	305A	056	033	1-G7		
0895	16	460B	048	011	1-H6	3648	17	308	056	035	1-G7		
0820	16	510	048	012	1-H6	3648	17	310	057	037	1-H7		
0820	16	515	049	013	1-I6	0118	17	313	060	001	1-J7		
0454	16	520	049	014	1-I6	0118	17	313	061	036	1-K7		
0839	17	111	051	001	1-C7	0821	17	313	057	038	1-H7		
0839	17	111	053	040	1-E7	0884	17	315	057	039	1-H7		
0107	17	121	051	002	1-C7	0884	17	316A	057	040	1-H7		
3778	17	200A	051	003	1-C7	0884	17	317A	057	040	1-H7		
1853	17	201	055	001	1-F7	0884	17	318A	057	040	1-H7		
0810	17	204	055	005	1-F7	4059	17	323	057	042	1-H7		
0810	17	205	055	006	1-F7	0884	17	325B	057	044	1-H7		
3648	17	221	055	007	1-F7	0305	17	327	057	046	1-H7		
0317	17	225	055	009	1-F7	0305	17	328	057	046	1-H7		
3778	17	231	055	010	1-F7	3778	17	330B	051	014	1-C7		
1853	17	241	055	011	1-F7	0398	17	333	051	015	1-C7		
0187	17	243	055	008	1-F7	0437	17	335	052	016	1-D7		
1853	17	243	055	012	1-F7	0437	17	335	081	035	1-G9		
0103	17	244A	055	013	1-F7	0862	17	341	057	047	1-H7		
1853	17	244	055	014	1-F7	1281	17	341	091	001	1-H10		
0862	17	245A	055	015	1-F7	0114	17	351	060	003	1-J7		
1853	17	245	055	016	1-F7	0862	17	351	052	018	1-D7		
3778	17	251	055	019	1-F7	0862	17	351	080	001	1-F9		
1853	17	261A	056	020	1-G7	0187	17	352	052	019	1-D7		
1853	17	262	056	021	1-G7	0187	17	352	080	002	1-F9		
1853	17	264	055	017	1-F7	0111	17	354	052	020	1-D7		
1853	17	265	055	018	1-F7	0111	17	354	080	003	1-F9		
3778	17	271	056	022	1-G7	1281	17	371	052	022	1-D7		
0884	17	274	056	023	1-G7	0862	17	375	052	023	1-D7		
0884	17	275A	056	024	1-G7	0862	17	375	053	040	1-E7		
3648	17	275	056	025	1-G7	0810	17	381A	052	025	1-D7		
0839	17	276	056	026	1-G7	0810	17	385	052	026	1-D7		
0839	17	277	056	026	1-G7	0810	17	385	053	040	1-E7		
0839	17	276	056	026	1-G7	3778	17	393	052	029	1-D7		
3648	17	281B	057	051	1-H7	3778	17	393	053	040	1-E7		
3648	17	281C	057	051	1-H7	1853	17	402A	060	004	1-J7		

PARTS NUMBER	PARTS COMP. LIST PAGE	FIG. NO.	FICHE INDEX	PARTS NUMBER	PARTS COMP. LIST PAGE	FIG. NO.	FICHE INDEX		
1853	17 404	060	005	1-J7	0221	17 552	062	040	1-L7
3778	17 406	060	006	1-J7	3648	17 611	057	049	1-H7
3648	17 410	060	007	1-J7	0884	17 612	057	050	1-H7
0103	17 411	060	008	1-J7	3648	17 621	058	056	1-I7
0498	17 411A	060	009	1-J7	3648	17 622A	058	057	1-I7
3648	17 414	062	046	1-L7	3648	17 626	058	058	1-I7
3648	17 415	062	047	1-L7	3648	17 629	057	052	1-H7
3648	17 416	062	048	1-L7	0884	17 633A	058	053	1-I7
0498	17 421B	060	010	1-J7	0834	17 634A	058	053	1-I7
0498	17 422	060	011	1-J7	0884	17 635A	058	053	1-I7
3648	17 431	060	012	1-J7	0884	17 636A	058	053	1-I7
3648	17 432	060	013	1-J7	0862	17 641	058	055	1-I7
0821	17 433	060	014	1-J7	0862	17 642	058	055	1-I7
0221	17 441	060	015	1-J7	0862	17 643	058	055	1-I7
0259	17 441	060	016	1-J7	0862	17 644	058	055	1-I7
3790	17 441	052	030	1-D7	0862	17 660A	051	005	1-C7
3790	17 441	060	005	1-F9	1562	18 100A	064	001	1-C8
0862	17 442	052	031	1-D7	1672	18 100A	064	002	1-C8
0862	17 442	060	006	1-F9	0578	18 101	065	016	1-D8
3778	17 450A	061	020	1-K7	0845	18 101	065	016	1-D8
860*	17 461	061	021	1-K7	3648	18 101	065	017	1-D8
0398	17 462A	061	022	1-K7	0823	18 107	064	003	1-C8
3648	17 463	061	023	1-K7	3790	18 110A	064	004	1-C8
3648	17 463A	061	023	1-K7	3648	18 111	064	005	1-C8
3648	17 464	061	024	1-K7	0820	18 114	064	010	1-C8
3648	17 465	061	025	1-K7	3790	18 115	064	006	1-C8
0498	17 470	061	027	1-K7	1854	18 120	064	007	1-C8
0647	17 473	061	030	1-K7	1757	18 130A	064	011	1-C8
0303	17 474	053	040	1-E7	1757	18 140B	064	012	1-C8
0303	17 474	062	043	1-L7	1757	18 150D	064	009	1-C8
0862	17 475	061	032	1-K7	1854	18 160	064	008	1-C8
0271	17 475	053	040	1-E7	1757	18 170A	064	013	1-C8
0271	17 475	061	033	1-K7	1757	18 180A	064	014	1-C8
0303	17 482	062	044	1-L7	3648	18 190	064	015	1-C8
0824	17 483	061	034	1-K7	3790	18 200	065	020	1-D8
0163	17 491	061	035	1-K7	0107	18 216A	065	021	1-D8
0821	17 505A	062	041	1-L7	0810	18 276	040	051	1-F5
3794	17 510	061	037	1-K7	0810	18 277	040	051	1-F5
1274	17 520	061	038	1-K7	1011	18 300	069	001	1-G8
0884	17 530	053	040	1-E7	1757	18 311	070	020	1-H8
0862	17 531A	053	035	1-E7	1881	18 361A	070	023	1-H8
0862	17 535	053	036	1-E7	0222	18 375	070	026	1-H8
0862	17 535	053	040	1-E7	0222	18 376	070	026	1-H8
0862	17 540B	053	038	1-E7	0222	18 377	070	026	1-H8
3648	17 551A	062	039	1-L7	1672	18 381A	070	027	1-H8

PARTS NUMBER	PARTS COMP. LIST PAGE	FIG. NO.	FICHE INDEX	PARTS NUMBER	PARTS COMP. LIST PAGE	FIG. NO.	FICHE INDEX
0453 18 391	066	039	1-E8	0338 19 337	080	014	1-F9
1757 18 4000	072	001	1-I8	0338 19 338	080	015	1-F9
1757 18 4000	072	001	1-I8	1758 19 341	080	018	1-F9
1758 18 4000	072	001	1-I8	0378 19 344	080	016	1-F9
1758 18 401A	074	026	1-K8	0338 19 360	085	001	1-C10
1757 18 510A	003	032	1-D1	0338 19 360A	085	001	1-C10
1881 18 510	003	032	1-D1	0338 19 361	081	019	1-G9
0504 18 520B	074	025	1-K8	0338 19 363	081	020	1-G9
8715 18 520	074	025	1-K8	0842 19 381	081	021	1-G9
3743 18 600	066	041	1-E8	0338 19 384	081	022	1-G9
2691 18 660	234	001	3-C10	0842 19 385	081	023	1-G9
3648 18 810	066	042	1-E8	1758 19 386	081	024	1-G9
3648 18 860	074	029	1-K8	0338 19 388A	081	025	1-G9
3648 18 861A	074	030	1-K8	0338 19 389	081	026	1-G9
3597 18 862	018	003	1-E2	1758 19 391A	081	027	1-G9
3597 18 862	018	010	1-E2	1758 19 392A	081	028	1-G9
1881 18 860A	074	032	1-K8	0842 19 394	081	029	1-G9
1259 18 890	066	044	1-E8	1758 19 394A	081	030	1-G9
8712 18 940B	067	047	1-F8	0338 19 395	081	031	1-G9
8735 18 940A	067	047	1-F8	0338 19 397	081	032	1-G9
8736 18 940A	067	047	1-F8	0338 19 397	092	025	1-I10
1758 19 020	076	002	1-C9	1758 19 397	081	033	1-G9
0842 19 025	076	004	1-C9	1181 19 431B	095	003	1-K10
1908 19 027	076	006	1-C9	1758 19 440A	095	005	1-K10
0454 19 028A	076	007	1-C9	1758 19 443	095	006	1-K10
1758 19 028	076	009	1-C9	0338 19 449	095	007	1-K10
1015 19 031	095	001	1-K10	1758 19 450	095	008	1-K10
1758 19 036A	096	019	1-L10	1758 19 460	085	002	1-C10
1758 19 055	096	020	1-L10	0338 19 470	085	003	1-C10
3649 19 064	076	003	1-C9	0338 19 475	085	004	1-C10
3649 19 090A	078	044	1-E9	0338 19 475	086	016	1-D10
8501 19 100	076	012	1-C9	0338 19 475	088	047	1-F10
1758 19 211B	076	013	1-C9	0338 19 476	085	005	1-C10
1758 19 215	076	014	1-C9	0338 19 476	086	017	1-D10
0338 19 216	076	015	1-C9	0338 19 476	088	047	1-F10
1758 19 220	076	016	1-C9	0338 19 480	085	006	1-C10
0338 19 223	076	017	1-C9	0338 19 480	086	018	1-D10
1758 19 240	076	018	1-C9	0338 19 486	085	007	1-C10
0338 19 245A	077	019	1-D9	0338 19 486	086	019	1-D10
0338 19 256	077	020	1-D9	0338 19 486	088	047	1-F10
0338 19 257	077	021	1-D9	0338 19 487	085	008	1-C10
0338 19 256	077	022	1-D9	0338 19 487	086	020	1-D10
1181 19 310B	080	010	1-F9	0338 19 487	088	047	1-F10
0338 19 331A	080	011	1-F9	0338 19 488	085	009	1-C10
0338 19 336	080	013	1-F9	0338 19 488	086	021	1-D10

PARTS NUMBER	PARTS COMP. LIST PAGE	FIG. NO.	FICHE INDEX	PARTS NUMBER	PARTS COMP. LIST PAGE	FIG. NO.	FICHE INDEX
0338 19 488	088	047	1-F10	0338 19 601	091	012	1-H10
0338 19 498	085	010	1-C10	0338 19 603	091	013	1-H10
0338 19 498	086	022	1-D10	0338 19 604	091	014	1-H10
0338 19 498	088	047	1-F10	0338 19 605	091	015	1-H10
0338 19 499	085	011	1-C10	0338 19 606	091	016	1-H10
0338 19 499	086	023	1-D10	0338 19 607	091	017	1-H10
0338 19 499	088	047	1-F10	0338 19 608	092	018	1-I10
0338 19 500	085	012	1-C10	0338 19 609	092	019	1-I10
0338 19 500	086	024	1-D10	0338 19 610	092	020	1-I10
0338 19 500	088	047	1-F10	0338 19 610A	092	020	1-I10
0338 19 500A	085	012	1-C10	1758 19 613	092	021	1-I10
0338 19 500A	086	024	1-D10	1758 19 614	092	021	1-I10
0338 19 500A	088	047	1-F10	1758 19 615	092	021	1-I10
1758 19 503	085	013	1-C10	1758 19 616	092	021	1-I10
1758 19 504	085	013	1-C10	1758 19 617	092	021	1-I10
1758 19 505	085	013	1-C10	1758 19 618	092	021	1-I10
1758 19 506	085	013	1-C10	0338 19 619	092	022	1-I10
1758 19 507	085	013	1-C10	0338 19 621	087	040	1-E10
1758 19 508	085	013	1-C10	0338 19 621	089	047	1-E10
0338 19 509	085	014	1-C10	0338 19 622	087	041	1-E10
0338 19 509	086	025	1-D10	0338 19 622	092	023	1-I10
0338 19 509	086	047	1-F10	0338 19 623	087	042	1-E10
1758 19 510	086	015	1-D10	0338 19 624	087	043	1-E10
1758 19 511	086	026	1-D10	0338 19 631	087	044	1-E10
0378 19 515	086	027	1-D10	0338 19 632	087	044	1-E10
0338 19 530	086	028	1-D10	0338 19 633	087	044	1-E10
0338 19 531	086	029	1-D10	0338 19 634	087	044	1-E10
0338 19 533	086	030	1-D10	0338 19 635	087	044	1-E10
0338 19 534	086	031	1-D10	0338 19 636	087	044	1-E10
0338 19 540	087	032	1-E10	0338 19 638	088	045	1-F10
0338 19 550	087	033	1-E10	0338 19 638	089	047	1-G10
0338 19 560	087	034	1-E10	0338 19 639	088	046	1-F10
0338 19 565	087	035	1-E10	0338 19 641	088	047	1-F10
0338 19 566	087	036	1-E10	0338 19 642	088	047	1-F10
0338 19 567	087	037	1-E10	0338 19 643	088	047	1-F10
0338 19 570	087	038	1-E10	0338 19 644	088	047	1-F10
0338 19 580	091	004	1-H10	0338 19 645	088	047	1-F10
0338 19 581	091	005	1-H10	0338 19 646	088	047	1-F10
0338 19 590	091	006	1-H10	0338 19 647	088	047	1-F10
0338 19 591	091	007	1-H10	0842 19 650	092	024	1-I10
0338 19 593	091	008	1-H10	0338 19 651	092	026	1-I10
0338 19 594	091	009	1-H10	0338 19 655	092	027	1-I10
0338 19 595	091	010	1-H10	0338 19 656	092	028	1-I10
0338 19 596	091	011	1-H10	0436 19 656	092	045	1-F10
0338 19 598	087	039	1-E10	0436 19 656	089	045	1-G10

PARTS NUMBER	PARTS COMP. LIST PAGE	FIG. NO.	FICHE INDEX	PARTS NUMBER	PARTS COMP. LIST PAGE	FIG. NO.	FICHE INDEX
0842 19 660	092	029	1-I10	1053 19 920B	077	030	1-D9
0338 19 661	092	030	1-I10	1053 19 930B	077	031	1-D9
0338 19 663	092	031	1-I10	1015 19 934C	077	032	1-D9
0338 19 664	093	032	1-J10	1098 19 939	077	035	1-D9
0842 19 665	093	033	1-J10	1015 19 945A	077	033	1-D9
0338 19 666	093	034	1-J10	2579 19 989	077	034	1-D9
0338 19 667	093	035	1-J10	0397 22 200	088	047	1-F10
0338 19 670A	093	036	1-J10	0881 22 297	058	059	1-I7
0338 19 676	093	037	1-J10	0866 23 025	007	085	1-H1
0338 19 678	077	023	1-D9	0866 23 025	008	085	1-I1
0338 19 701A	095	009	1-K10	1757 23 040A	007	085	1-H1
0338 19 702A	095	010	1-K10	1757 23 040B	007	085	1-H1
0338 19 703	095	011	1-K10	3648 23 050A	003	026	1-D1
0338 19 704	095	012	1-K10	3648 23 070	006	075	1-G1
0338 19 706	095	013	1-K10	8712 23 075	005	061	1-F1
1840 19 710	081	034	1-G9	1757 23 103	013	050	1-M1
0338 19 731	095	015	1-K10	1011 23 151A	013	052	1-M1
0338 19 732	095	016	1-K10	8735 23 180	013	053	1-M1
0338 19 733C	095	017	1-K10	3790 23 200	007	085	1-H1
0338 19 734A	096	018	1-L10	3791 23 200	007	085	1-H1
0338 19 755	081	036	1-G9	8503 23 318	024	004	1-C3
0338 19 737	082	037	1-H9	8712 23 319	027	064	1-F3
0338 19 739	082	037	1-H9	3787 23 323	027	064	1-F3
3649 19 750	082	038	1-H9	3648 23 324	024	006	1-C3
0338 19 768	082	039	1-H9	3565 23 325	024	007	1-C3
1758 19 815	082	040	1-H9	3565 23 326	024	008	1-C3
1675 19 821	082	044	1-H9	3565 23 327	024	009	1-C3
0338 19 822	082	045	1-H9	3787 23 331	024	010	1-C3
1758 19 823	082	046	1-H9	3565 23 332	024	011	1-C3
0338 19 825	082	047	1-H9	3648 23 337	027	064	1-F3
0338 19 826	082	047	1-H9	3565 23 349	024	012	1-C3
0338 19 827	082	047	1-H9	8527 23 350	024	013	1-C3
0338 19 828	082	047	1-H9	3787 23 353	024	014	1-C3
0338 19 829	082	047	1-H9	3565 23 354	024	015	1-C3
0338 19 831	082	041	1-H9	0187 23 356	024	016	1-C3
0338 19 832	082	042	1-H9	0291 23 366	024	017	1-C3
0338 19 833	082	043	1-H9	3648 23 370	024	018	1-C3
1758 19 835	082	048	1-H9	8501 23 374	024	019	1-C3
1758 19 836	083	049	1-I9	3648 23 375	025	020	1-D3
0338 19 837	083	050	1-I9	8712 23 380	025	021	1-D3
1856 19 870A	083	051	1-I9	8504 23 390	025	022	1-D3
1758 19 880	083	052	1-I9	8712 23 393	025	023	1-D3
0338 19 904A	077	026	1-D9	3565 23 394	025	024	1-D3
0808 19 910	077	027	1-D9	1208 23 395	025	025	1-D3
0842 19 915A	077	028	1-D9	8503 23 401	025	027	1-D3

PARTS NUMBER		PARTS COMP. LIST PAGE	FIG. NO.	FICHE INDEX	PARTS NUMBER		PARTS COMP. LIST PAGE	FIG. NO.	FICHE INDEX
3787 23 409	025	028	1-D3	3648 23 693A	020	006	1-F2		
3787 23 410	025	029	1-D3	1757 23 713	030	002	1-C4		
3789 23 410	025	029	1-D3	1757 23 725	031	020	1-D4		
1029 23 411	025	030	1-D3	0839 23 801	038	025	1-D5		
8712 23 420	025	031	1-D3	0813 23 802B	038	022	1-D5		
8712 23 422	025	032	1-D3	0813 23 803	038	023	1-D5		
3565 23 423	025	033	1-D3	0820 23 832B	038	029	1-D5		
3626 23 424	025	034	1-D3	0730 23 837	039	034	1-E5		
3565 23 426	025	035	1-D3	0730 23 839	039	035	1-E5		
3565 23 427	025	036	1-D3	8501 23 882	037	014	1-C5		
3565 23 428	025	037	1-D3	1757 24 302	065	022	1-D8		
8712 23 430	027	063	1-F3	3648 24 303	065	023	1-D8		
1757 23 433	027	064	1-F3	3648 24 304	066	036	1-E8		
8501 23 440	025	038	1-D3	3648 24 305	066	036	1-E8		
3565 23 446	026	039	1-E3	8735 24 308	065	024	1-D8		
3787 23 446	026	039	1-E3	1757 24 310	065	025	1-D8		
1757 23 450	026	040	1-E3	8735 24 313	065	026	1-D8		
1757 23 455	026	041	1-E3	1757 24 314	065	027	1-D8		
3565 23 460	026	042	1-E3	1757 24 317	065	028	1-D8		
3787 23 460	026	042	1-E3	8735 24 319	065	029	1-D8		
3787 23 461	026	043	1-E3	1757 24 322	066	030	1-E8		
3565 23 462	026	044	1-E3	3648 24 323	066	036	1-E8		
3565 23 464	026	045	1-E3	8735 24 330	066	032	1-E8		
1757 23 470	026	046	1-E3	1757 24 334	066	035	1-E8		
5900 23 471	026	047	1-E3	3648 24 340	066	034	1-E8		
1029 23 480	026	048	1-E3	3775 24 350	066	035	1-E8		
1757 23 481	026	049	1-E3	3790 24 351	066	036	1-E8		
3565 23 490	026	050	1-E3	8650 24 351	066	036	1-E8		
8501 23 491	026	051	1-E3	1011 24 501	069	002	1-G8		
3565 23 495	026	052	1-E3	0820 24 503	069	008	1-G8		
3565 23 496	026	053	1-E3	1011 24 510	069	013	1-G8		
3787 23 500	026	054	1-E3	0208 24 514	069	010	1-G8		
3565 23 501	026	055	1-E3	0866 24 526	069	011	1-G8		
1757 23 507	026	056	1-E3	1011 24 527	069	003	1-G8		
3565 23 508	027	057	1-F3	0866 24 530	069	004	1-G8		
3787 23 510	027	058	1-F3	0866 24 533	069	005	1-G8		
8527 23 519	027	064	1-F3	1011 24 533	069	014	1-G8		
3787 23 520	027	059	1-F3	1011 24 534	069	015	1-G8		
3788 23 522	026	069	1-G3	0866 24 535	069	006	1-G8		
3787 23 540	028	069	1-G3	0866 24 540A	069	007	1-G8		
3565 23 549	027	061	1-F3	1011 24 541	069	016	1-G8		
3565 23 652	027	062	1-F3	0866 24 550	069	009	1-G8		
1757 23 672	020	003	1-F2	1011 24 560	069	012	1-G8		
3648 23 673	020	004	1-F2	1011 24 563	069	017	1-G8		
1757 23 680	020	005	1-F2	8028 24 581	069	018	1-G8		

PARTS NUMBER	PARTS COMP. LIST PAGE	FIG. NO.	FICHE INDEX	PARTS NUMBER	PARTS COMP. LIST PAGE	FIG. NU.	FICHE INDEX
0866 24 704	072	002	1-18	0259 26 051	101	003	2-E1
1758 24 705	072	003	1-18	0419 26 060	101	004	2-E1
3648 24 705	072	003	1-18	1854 26 111A	101	010	2-E1
1758 24 706	073	021	1-J8	1854 26 113A	101	012	2-E1
1757 24 709	072	004	1-18	1854 26 115A	101	010	2-E1
3648 24 709	072	004	1-18	0604 26 125B	102	013	2-F1
1757 24 710B	072	005	1-18	0604 26 129	102	014	2-F1
1757 24 710C	072	005	1-18	0603 26 131A	102	015	2-F1
1758 24 710A	072	005	1-18	0603 26 152	102	017	2-F1
0426 24 712	072	006	1-18	0603 26 153	102	018	2-F1
0426 24 715A	072	007	1-18	0603 26 154	102	019	2-F1
0866 24 716	072	008	1-18	0603 26 155	102	020	2-F1
0845 24 720	072	009	1-18	0603 26 156	102	017	2-F1
0426 24 725	072	010	1-18	0603 26 157	102	021	2-F1
0426 24 726	072	011	1-18	1854 26 161B	106	032	2-I1
1758 24 726	072	011	1-18	1854 26 161B	124	001	2-C4
0222 24 730	072	008	1-18	1854 26 161B	135	014	2-C6
1757 24 730A	072	012	1-18	0603 26 165	102	022	2-F1
1758 24 730B	072	012	1-18	0603 26 166	102	022	2-F1
0426 24 731	072	013	1-18	0603 26 167	102	022	2-F1
1758 24 731A	072	013	1-18	0603 26 168	102	022	2-F1
1758 24 735	073	020	1-J8	0603 26 251A	104	001	2-G1
0222 24 743	072	009	1-18	0603 26 281B	104	003	2-G1
0222 24 741	073	014	1-J8	0589 26 287A	104	004	2-G1
1758 24 750	073	015	1-J8	0603 26 288	104	005	2-G1
0222 24 753	073	017	1-J8	0603 26 291B	104	005	2-G1
0426 24 753	073	018	1-J8	0589 26 297A	104	004	2-G1
0426 24 754	073	019	1-J8	0603 26 301	104	006	2-G1
1757 24 760	073	020	1-J8	1823 26 310B	104	007	2-G1
2677 25 015	098	002	2-C1	1823 26 312B	104	008	2-G1
2677 25 071	098	005	2-C1	0603 26 341	104	009	2-G1
2677 25 072	098	005	2-C1	0223 26 345A	104	010	2-G1
2677 25 073	098	005	2-C1	0223 26 391	104	011	2-G1
2677 25 074	098	005	2-C1	0604 26 465	105	013	2-H1
2677 25 075	098	005	2-C1	3874 26 510	105	012	2-H1
2677 25 076	098	005	2-C1	1854 26 570A	107	034	2-J1
2677 25 077	098	005	2-C1	0647 26 610A	104	012	2-G1
3790 25 100	098		2-C1	0208 26 671	105	014	2-H1
0578 25 130	098	003	2-C1	0647 26 710A	105	012	2-H1
0290 25 151	098	006	2-C1	0603 26 800A	105	024	2-H1
3790 25 210	098	007	2-C1	0603 26 810A	105	024	2-H1
2677 25 220	098	008	2-C1	0603 26 821A	106	026	2-I1
1856 25 300A	099	009	2-D1	0604 26 832	105	025	2-H1
1856 25 314	099	014	2-D1	0118 26 834	106	027	2-I1
3790 26 010	101	001	2-E1	0603 26 898	106	029	2-I1

PARTS NUMBER	PARTS COMP. LIST PAGE	FIG. NO.	FICHE INDEX	PARTS NUMBER	PARTS COMP. LIST PAGE	FIG. NO.	FICHE INDEX
0012 27 012	109	001	2-C2	0603 28 140	113	007	2-F2
0604 27 018	109	002	2-C2	0603 28 142	113	008	2-F2
3790 27 100	109		2-C2	0603 28 151	114	011	2-G2
3790 27 110	109	003	2-C2	0603 28 152	114	012	2-G2
0579 27 120A	109	004	2-C2	0603 28 161	114	013	2-G2
0578 27 130A	109	005	2-C2	0603 28 171	114	011	2-G2
0603 27 141	109	006	2-C2	0603 28 320	114	015	2-G2
0604 27 142	109	007	2-C2	3874 28 330	113	006	2-F2
0578 27 150B	109	008	2-C2	3874 28 350	113	010	2-F2
0305 27 171	109	010	2-C2	3874 28 700	114	016	2-G2
3874 27 231	110	011	2-D2	3874 28 981	114	021	2-G2
0603 27 251	110	014	2-D2	1854 32 018	116	002	2-C3
0578 27 252	110	015	2-D2	1175 32 030	116	003	2-C3
0578 27 253	110	015	2-D2	1175 32 041	116	004	2-C3
0578 27 254	110	015	2-D2	1175 32 042	116	005	2-C3
0603 27 255	110	016	2-D2	1175 32 043	116	006	2-C3
0578 27 261	110	017	2-D2	1175 32 044	116	007	2-C3
0114 27 262	110	018	2-D2	1854 32 049	116	008	2-C3
0603 27 263	110	019	2-D2	1854 32 050A	116	014	2-C3
0110 27 301	111	020	2-E2	0208 32 059	117	016	2-D3
0578 27 302	111	021	2-E2	0259 32 071	117	017	2-D3
0110 27 303	111	023	2-E2	1854 32 080	117	018	2-D3
0223 27 401A	111	024	2-E2	1854 32 110	117	018	2-D3
0223 27 402A	111	024	2-E2	0603 32 122	117	019	2-D3
0223 27 403A	111	024	2-E2	0603 32 122	117	020	2-D3
0223 27 404A	111	024	2-E2	1854 32 130	117	021	2-D3
0223 27 405A	111	024	2-E2	1854 32 141	117	022	2-D3
0223 27 406A	111	024	2-E2	1854 32 151	117	023	2-D3
0223 27 407A	111	024	2-E2	1854 32 154	117	024	2-D3
0223 27 408A	111	024	2-E2	1854 32 155	117	024	2-D3
0223 27 409A	111	024	2-E2	1854 32 156	117	024	2-D3
0223 27 411A	111	024	2-E2	1854 32 157	117	024	2-D3
0223 27 412A	111	024	2-E2	1854 32 158	117	024	2-D3
0223 27 413A	111	024	2-E2	1854 32 159	117	024	2-D3
0223 27 414A	111	024	2-E2	1854 32 161	117	025	2-D3
0223 27 415A	111	024	2-E2	1854 32 163	117	026	2-D3
3874 28 010A	113	001	2-F2	0180 32 165A	117	027	2-D3
3874 28 011	113	001	2-F2	0180 32 171A	117	028	2-D3
3874 28 012	113	001	2-F2	0180 32 172A	118	028	2-E3
3874 28 013	113	001	2-F2	0180 32 173A	118	028	2-E3
3874 28 014	113	001	2-F2	0180 32 174A	118	028	2-E3
3874 28 015	113	001	2-F2	0183 32 182	118	030	2-E3
3874 28 016	113	001	2-F2	0180 32 184	118	031	2-E3
0603 28 110	113	002	2-F2	0603 32 186	118	036	2-E3
0603 28 114	113	005	2-F2	0208 32 188	118	038	2-E3

PARTS NUMBER	PARTS COMP. LIST PAGE	FIG. NO.	FICHE INDEX	PARTS NUMBER	PARTS COMP. LIST PAGE	FIG. NO.	FICHE INDEX
0820 32 190	118	033	2-E3	1854 33 192	107	037	2-J1
3874 32 226	113	039	2-E3	1854 33 192	125	021	2-D4
3790 32 250	121	001	2-G3	0305 33 235	126	039	2-E4
1854 32 267	121	005	2-G3	1854 33 251	125	022	2-D4
0208 32 278	121	008	2-G3	1854 33 260	125	023	2-D4
0206 32 278	126	001	2-C5	1854 33 270	125	023	2-D4
0208 32 278	131	035	2-F5	3874 33 280	125	027	2-D4
0208 32 278	131	040	2-F5	0304 33 352A	105	021	2-H1
0187 32 279A	131	036	2-F5	3874 33 610	125	028	2-D4
1823 32 279	121	002	2-G3	0305 33 626A	126	040	2-E4
1823 32 279	122	026	2-H3	0296 33 636	126	041	2-E4
0187 32 289	131	037	2-F5	0296 33 646	126	041	2-E4
1823 32 289	121	003	2-G3	2981 33 651	126	029	2-E4
1823 32 289	122	027	2-H3	0187 33 671A	105	014	2-H1
3874 32 301	124	002	2-C4	2981 33 671	126	030	2-E4
3874 32 311	124	002	2-C4	1312 33 673	105	015	2-H1
2541 32 320	121	007	2-G3	0803 33 681A	105	016	2-H1
0208 32 324B	121	009	2-G3	2981 33 681A	126	031	2-E4
0208 32 326	121	010	2-G3	0305 33 685A	126	032	2-E4
0208 32 328A	121	011	2-G3	0233 33 691	126	033	2-E4
0208 32 329	121	012	2-G3	0259 33 691	105	017	2-H1
0208 32 331A	121	013	2-G3	0259 33 691	154	011	2-E9
0208 32 340A	121	014	2-G3	0259 33 693	105	018	2-H1
2541 32 351A	122	016	2-H3	0259 33 693	154	012	2-E9
0603 32 355	122	019	2-H3	0600 33 693	126	034	2-E4
0208 32 360A	122	017	2-H3	0305 33 695	126	035	2-E4
0603 32 365B	122	021	2-H3	0305 33 695	126	035	2-E4
1757 32 411A	119	041	2-F3	0305 33 696	126	036	2-E4
1757 32 411B	119	041	2-F3	0221 33 698	125	024	2-D4
1854 32 421	119	043	2-F3	0305 33 698A	126	037	2-E4
1793 32 800	119	047	2-F3	0305 33 699	125	025	2-D4
1727 32 811	119	046	2-F3	3874 33 710	126	028	2-E4
1854 32 888	116	015	2-C3	3874 33 980	125	026	2-D4
1854 32 980	116	001	2-C3	3874 33 990	125	026	2-D4
0223 33 021B	124	007	2-C4	3874 34 011	128	002	2-C5
0223 33 031B	124	007	2-C4	3874 34 013	128	004	2-C5
0110 33 041	124	009	2-C4	0603 34 110C	128	003	2-C5
0662 33 042	124	011	2-C4	0603 34 130B	128	006	2-C5
0662 33 049	124	012	2-C4	1854 34 151	133	001	2-G5
1854 33 061A	125	016	2-D4	0603 34 153	114	017	2-G2
1854 33 062A	125	017	2-D4	0603 34 153	133	002	2-G5
3900 33 065	125	018	2-D4	0603 34 153	133	003	2-G5
1854 33 071	125	019	2-D4	0603 34 156	133	004	2-G5
1854 33 191	107	036	2-J1	0603 34 157A	133	006	2-G5
1854 33 191	125	020	2-D4	0603 34 158	133	007	2-G5

3874 34 310	128	013	2-C5	1854 40 096A	142	006	2-C7
3874 34 360	129	013	2-D5	1854 40 097A	142	007	2-C7
0223 34 411	129	013	2-D5	3900 40 160	142	009	2-C7
0603 34 416	129	016	2-D5	0820 40 160	142	010	2-C7
3874 34 431	129	017	2-D5	1114 40 170	142	011	2-C7
0602 34 471A	129	020	2-D5	2158 40 355	016	019	1-02
0603 34 515	131	041	2-F5	2158 40 355	142	013	2-C7
0187 34 536	131	042	2-F5	1757 40 356	143	016	2-D7
0193 34 662	129	021	2-D5	0111 40 358	223	047	3-G8
0187 34 665	130	023	2-E5	0824 40 401	143	017	2-D7
0187 34 666	130	023	2-E5	1854 40 405	143	019	2-D7
0187 34 667	130	023	2-E5	1854 40 405A	143	019	2-D7
0187 34 668	130	023	2-E5	3900 40 500B	143	020	2-D7
0633 34 673	130	024	2-E5	2090 40 508A	143	021	2-D7
3874 34 700	130	025	2-E5	3790 40 600A	143	022	2-D7
0187 34 776	114	018	2-G2	1854 40 810C	143	023	2-D7
0187 34 776	133	008	2-G5	1854 40 821A	143	024	2-D7
0187 34 777	114	019	2-G2	3790 40 830	143	025	2-D7
0187 34 797	130	027	2-E5	1114 40 850B	143	026	2-D7
0187 34 798	130	028	2-E5	0727 41 023	151	002	2-C9
0187 34 799	130	029	2-E5	1854 41 030A	151	001	2-C9
0193 34 820	130	032	2-E5	0824 41 131	151	003	2-C9
0193 34 940	130	033	2-E5	1872 41 140	151	004	2-C9
1854 37 790A	254	001	3-C13	1872 41 142	151	005	2-C9
3790 38 010A	135	001	2-C6	0180 41 308	151	006	2-C9
3790 38 200	135	002	2-C6	0603 41 331	154	013	2-E9
1859 38 551	135	003	2-C6	1381 41 341	154	014	2-E9
1854 38 558	135	005	2-C6	0118 41 380A	154	001	2-E9
3790 38 560	135	006	2-C6	1011 41 400A	154	002	2-E9
3790 38 581	135	014	2-C6	0305 41 451	154	007	2-E9
3790 38 590	135	010	2-C6	0839 41 461	154	003	2-E9
1854 38 610B	136	015	2-D6	1854 41 610B	145	001	2-E7
1854 38 650A	136	015	2-D6	2158 41 619	145	002	2-E7
1854 38 810	136	018	2-D6	0305 41 641	145	003	2-E7
1854 38 851A	136	020	2-D6	0259 41 644	145	005	2-E7
1854 39 020A	139	001	2-F6	1856 41 650	145	007	2-E7
1668 39 040C	139	003	2-F6	1854 41 660C	145	008	2-E7
1668 39 040D	139	003	2-F6	0118 41 681	145	010	2-E7
1668 39 045A	139	005	2-F6	0118 41 682	145	011	2-E7
1668 39 045B	139	005	2-F6	0111 41 692	186	043	3-G2

PARTS NUMBER		PARTS COMP. LIST PAGE	FIG. NO.	FICHE INDEX	PARTS NUMBER		PARTS COMP. LIST PAGE	FIG. NO.	FICHE INDEX
3792 41 711A	145	013	2-E7	1854 43 842	160	014	2-C10		
1881 41 920A	154	009	2-E9	1757 43 848	160	016	2-C10		
3787 42 310A	147	001	2-C8	0118 43 853	160	018	2-C10		
1854 42 330	147	005	2-C8	1011 43 890A	163	017	2-E10		
1854 42 338A	147	007	2-C8	3874 43 950	160	020	2-C10		
1854 42 339A	147	009	2-C8	1854 43 970	161	022	2-D10		
1854 42 342A	147	014	2-C8	1845 44 010	166	001	2-G10		
3787 42 350	147	015	2-C8	1845 44 020	166	002	2-G10		
1823 42 430	148	017	2-D8	2781 44 041	166	003	2-G10		
0136 42 434	148	018	2-D8	2781 44 042	166	004	2-G10		
3870 42 441	148	019	2-D8	0114 44 043	166	005	2-G10		
0136 42 449	148	021	2-D8	0183 44 045	166	006	2-G10		
3900 42 451	148	022	2-D8	0114 44 046	166	007	2-G10		
1854 42 717	148	025	2-D8	0114 44 051	166	008	2-G10		
3648 42 910	148	024	2-D8	0114 44 052	166	009	2-G10		
0229 43 028A	151	014	2-C9	0114 44 053	166	010	2-G10		
3792 43 025	151	007	2-C9	0114 44 056	166	012	2-G10		
3792 43 023	151	014	2-C9	1845 44 060	166	014	2-G10		
0187 43 029	151	008	2-C9	2541 44 063	167	015	2-H10		
0187 43 029	151	015	2-C9	1854 44 080	167	016	2-H10		
1854 43 030B	151	016	2-C9	1845 44 090	167	019	2-H10		
1856 43 030A	151	016	2-C9	1845 44 110	167	021	2-H10		
0866 43 061	151	017	2-C9	3874 44 150	167	022	2-H10		
0866 43 062	152	018	2-D9	0603 44 158A	167	023	2-H10		
3790 43 070	152	019	2-D9	0603 44 167	167	024	2-H10		
0603 43 081	152	024	2-D9	0603 44 261	167	025	2-H10		
1015 43 090	152	025	2-D9	0603 44 262	167	026	2-H10		
1854 43 140	152	027	2-D9	0603 44 270	168	030	2-110		
0707 43 390	163	002	2-E10	0603 44 272	168	032	2-110		
1854 43 400	157	001	2-G9	0603 44 357	168	033	2-110		
0111 43 432	154	004	2-E9	0118 44 375	168	034	2-110		
0111 43 433	154	004	2-E9	3790 44 410	168	035	2-110		
0118 43 505A	163	015	2-E10	3870 44 420	168	036	2-110		
0136 43 635	155	016	2-F9	0578 44 431	168	037	2-110		
0136 43 635	160	001	2-C10	0866 44 439	168	039	2-110		
0305 43 635	160	002	2-C10	3790 45 061	163	003	2-E10		
3790 43 650	160	003	2-C10	3919 45 170	164	033	2-F10		
3790 43 660	160	004	2-C10	1854 45 210	163	019	2-E10		
1570 43 694A	160	005	2-C10	3790 45 280	163	020	2-E10		
1570 43 694A	160	007	2-C10	3790 45 320	164	021	2-F10		
1854 43 800	158	013	2-H9	1854 45 340	164	022	2-F10		
1854 43 810	160	009	2-C10	3790 45 350	164	023	2-F10		
1757 43 830A	160	010	2-C10	3790 45 360	164	024	2-F10		
1854 43 830	160	011	2-C10	0571 45 451	164	025	2-F10		
1854 43 835	160	013	2-C10	0866 45 452	164	027	2-F10		

			PARTS COMP. LIST PAGE	FIG. NO.	FICHE INDEX				PARTS COMP. LIST PAGE	FIG. NO.	FICHE INDEX
PARTS NUMBER						PARTS NUMBER					
1854 45 550A	164	028	2-F10	0512 49 677	157	009	2-G9				
1854 45 631B	163	007	2-E10	0512 49 678	157	009	2-G9				
3790 45 731	163	009	2-E10	0305 49 686B	157	009	2-G9				
0866 45 903A	076	037	1-E9	0391 49 692	157	010	2-G9				
0866 45 903A	164	029	2-F10	0512 49 696	157	010	2-G9				
1304 45 903	164	030	2-F10	1854 49 720	158	014	2-H9				
1854 45 995	164	032	2-F10	0824 49 745	158	015	2-H9				
1015 46 010B	170	001	2-C11	2046 49 746	158	016	2-H9				
1244 46 021	170	002	2-C11	2046 49 747	158	017	2-H9				
1840 46 022	170	003	2-C11	0870 49 770	158	018	2-H9				
3598 46 030A	170	004	2-C11	0824 49 781	158	019	2-H9				
1244 46 032	170	006	2-C11	0824 49 782	158	020	2-H9				
1244 46 035	170	012	2-C11	0870 49 785	158	021	2-H9				
1244 46 035	170	007	2-C11	1854 50 031	173	001	3-C1				
1244 46 055	170	009	2-C11	1854 50 060	173	002	3-C1				
2375 46 061	170	014	2-C11	1854 50 062	173	004	3-C1				
2375 46 062	170	015	2-C11	1854 50 070	173	005	3-C1				
1015 46 081	170	017	2-C11	1854 50 072	173	005	3-C1				
1015 46 082	170	018	2-C11	1854 50 091	173	014	3-C1				
1015 46 083A	171	019	2-D11	1823 50 098	174	018	3-D1				
1015 46 085	151	009	2-C9	1854 50 110A	173	008	3-C1				
1015 46 085	152	051	2-D9	1854 50 120A	173	009	3-C1				
1015 46 085	171	020	2-D11	1854 50 130A	173	015	3-C1				
1856 46 110	171	021	2-D11	1854 50 165	173	016	3-C1				
1015 46 150A	171	023	2-D11	0223 50 275	173	006	3-C1				
1856 46 201	171	026	2-D11	0223 50 275	173	012	3-C1				
1856 46 571	171	030	2-D11	1854 50 511	174	020	3-D1				
1015 46 648	171	031	2-D11	1854 50 521	174	021	3-D1				
0223 46 683	151	010	2-C9	1854 50 531	174	022	3-D1				
1015 46 684	171	032	2-D11	1854 50 551	174	024	3-D1				
1015 46 691	171	037	2-D11	1854 51 020B	181	001	3-C2				
0841 49 230A	126	038	2-E4	1854 51 520B	181	002	3-C2				
1708 49 610	157	002	2-G9	0419 51 571A	240	001	3-H10				
0305 49 625	153	012	2-H9	3790 52 010	176	001	3-E1				
0305 49 626	157	012	2-G9	0187 52 141	176	002	3-E1				
1708 49 630	157	003	2-G9	0603 52 142	176	010	3-E1				
0305 49 638	157	004	2-G9	0603 52 143	176	011	3-E1				
1708 49 642	157	005	2-G9	0187 52 144	176	012	3-E1				
0512 49 651	157	006	2-G9	0603 52 160B	176	003	3-E1				
0512 49 652	157	007	2-G9	0603 52 210B	176	006	3-E1				
0305 49 656	157	008	2-G9	0603 52 214	177	014	3-F1				
0305 49 666	157	008	2-G9	0603 52 230	177	015	3-F1				
0512 49 667	157	008	2-G9	0603 52 232A	177	016	3-F1				
0512 49 668	157	008	2-G9	0603 52 260A	176	006	3-E1				
0512 49 676	157	009	2-G9	0259 52 301	194	031	3-E4				

PARTS NUMBER	PARTS COMP. LIST		FIG. NO.	FICHE INDEX	PARTS NUMBER	PARTS COMP. LIST		FIG. NO.	FICHE INDEX
	PAGE	PAGE				PAGE	PAGE		
0305 52 331	176		004	3-E1	3792 53 551C	184	007	3-E2	
0603 52 351A	178		028	3-G1	0603 53 552	184	009	3-E2	
0603 52 353	178		029	3-G1	2540 53 560A	184	011	3-E2	
0820 52 403	203		001	3-C6	3792 53 571	184	013	3-E2	
0603 52 451A	177		013	3-F1	3792 53 572	184	015	3-E2	
0603 52 472	177		019	3-F1	0603 53 573	184	017	3-E2	
0603 52 510	177		020	3-F1	3792 53 581	185	027	3-F2	
0208 52 520	177		021	3-F1	3790 53 591	184	010	3-E2	
0187 52 523	177		023	3-F1	3792 53 600	185	019	3-F2	
0187 52 531	177		025	3-F1	0603 53 611	185	020	3-F2	
0187 52 532	178		026	3-G1	3792 53 681A	185	022	3-F2	
2677 52 540A	178		030	3-G1	2651 53 682A	185	023	3-F2	
0603 52 543	178		031	3-G1	0603 53 683A	185	024	3-F2	
3790 53 030	181		007	3-C2	0603 53 684A	185	025	3-F2	
1854 53 035	181		010	3-C2	0576 53 685	185	026	3-F2	
1854 53 050A	181		008	3-C2	3790 53 700	185	028	3-F2	
1854 53 070	181		013	3-C2	3790 53 700A	185	028	3-F2	
1854 53 091B	181		014	3-C2	3790 53 710A	185	029	3-F2	
0613 53 103A	192		001	3-C4	0603 53 811B	189	017	3-C3	
3790 53 110	181		016	3-C2	2677 53 811A	189	015	3-C3	
0187 53 134	182		026	3-D2	0603 53 821	189	018	3-C3	
0187 53 134	182		030	3-D2	1854 53 891A	190	025	3-D3	
1854 53 160B	182		018	3-D2	1823 53 901	190	021	3-D3	
1854 53 161	182		023	3-D2	1823 53 901A	190	021	3-D3	
1854 53 200	182		020	3-D2	2651 53 901A	190	021	3-D3	
2541 53 220A	182		021	3-D2	2651 53 901B	190	021	3-D3	
1854 53 230C	182		023	3-D2	0603 53 902	190	022	3-D3	
1854 53 230D	182		023	3-D2	2541 53 902	190	022	3-D3	
0483 53 241	181		011	3-C2	3792 53 912	190	024	3-D3	
0603 53 305	197		081	3-H4	0221 53 916	185	027	3-F2	
3790 53 380	182		024	3-D2	3760 53 941	190	023	3-D3	
1823 53 410A	182		025	3-D2	3760 53 941A	190	023	3-D3	
0603 53 431D	189		003	3-C3	3764 53 941	190	023	3-D3	
0603 53 432A	189		004	3-C3	3764 53 941A	190	023	3-D3	
0603 53 433A	189		005	3-C3	0603 53 950A	136	022	2-D6	
0603 53 434B	189		006	3-C3	0603 53 950A	185	031	3-F2	
0603 53 434B	189		006	3-C3	0603 53 950A	185	033	3-F2	
0603 53 435	189		007	3-C3	0603 53 970	136	023	2-D6	
0603 53 435	189		008	3-C3	0603 53 970	185	034	3-F2	
0603 53 438	189		009	3-C3	0603 53 984A	137	024	2-E6	
0603 53 440B	189		010	3-C3	0603 53 984A	185	035	3-F2	
0193 53 462	190		020	3-D3	0603 53 984A	186	036	3-G2	
3792 53 510	184		001	3-E2	2541 53 991	190	027	3-D3	
0603 53 520A	184		003	3-E2	2541 53 992	190-	029	3-E3	
0603 53 531	184		005	3-E2	1854 54 050A	181	009	3-C2	

PARTS NUMBER	PARTS COMP. LIST PAGE	FIG. NU.	FICHE INDEX	PARTS NUMBER	PARTS COMP. LIST PAGE	FIG. NU.	FICHE INDEX
3790 54 110	181	017	3-C2	3792 56 700	186	042	3-G2
1854 54 160C	182	019	3-D2	1854 56 811	186	047	3-G2
1854 54 181	182	023	3-D2	1854 56 840C	186	048	3-G2
3792 54 220	182	022	3-D2	1854 56 851A	186	049	3-G2
1854 54 234	189	001	3-C3	0820 56 905	046	059	1-G6
0617 54 434	189	006	3-C3	0820 56 905	193	028	3-D4
3792 54 510	184	002	3-E2	3875 57 101	201	009	3-D5
0603 54 520A	184	004	3-E2	0603 57 102	200	001	3-C5
0603 54 531	184	006	3-E2	3875 57 102	201	009	3-D5
3792 54 551C	184	008	3-E2	0603 57 109	200	003	3-C5
0603 54 552	184	010	3-E2	0738 57 109	201-	1 020	3-E5
2540 54 560A	184	012	3-E2	0603 57 111	200	004	3-C5
3792 54 571	184	014	3-E2	0603 57 112	200	005	3-C5
3792 54 572	184	016	3-E2	2541 57 121	200	006	3-C5
0603 54 573	184	018	3-E2	3874 57 121	200	006	3-C5
3792 54 581	185	027	3-F2	3874 57 122	200	007	3-C5
3790 54 590	184	010	3-E2	2541 57 123	200	008	3-C5
0603 54 611	185	021	3-F2	3874 57 123	200	008	3-C5
3792 54 710A	185	030	3-F2	2541 57 124	200	008	3-C5
2677 54 821	190	019	3-D3	3874 57 124	200	008	3-C5
2541 54 991	190	028	3-D3	3874 57 125	201	009	3-D5
2541 54 992	190-	1 030	3-E3	3875 57 126	200	003	3-C5
1854 55 161	194	033	3-E4	3875 57 200	201	010	3-D5
2280 55 182	197	082	3-H4	3875 57 200A	201	010	3-D5
0274 55 200	197	084	3-H4	3875 57 220	201	011	3-D5
1854 55 220	192	002	3-C4	3875 57 300	201	013	3-D5
1011 55 240	192	006	3-C4	3875 57 300A	201	013	3-D5
1840 55 240	192	008	3-C4	3875 57 320	201	014	3-D5
0259 55 261	193	025	3-D4	3874 57 400	201	012	3-D5
1011 55 280	192	010	3-C4	3874 57 400A	201	012	3-D5
3787 55 430	192	013	3-C4	3874 57 650	201	015	3-D5
3790 55 430	192	013	3-C4	3874 57 680	201	016	3-D5
1854 55 490	192	012	3-C4	3770 57 900A00	201-	1 023	3-E5
3790 56 010	186	038	3-G2	3770 57 900B00	201-	1 023	3-E5
3790 56 010A	186	038	3-G2	3916 57 900A00	201-	1 023	3-E5
3875 56 031	186	039	3-G2	3770 57 920A00	201-	1 023	3-E5
3875 56 031A	186	039	3-G2	3770 57 920B00	201-	1 023	3-E5
3792 56 200	186	041	3-G2	3916 57 920A00	201-	1 023	3-E5
0118 56 241	186	044	3-G2	3794 57 991	201-	1 024	3-E5
0118 56 242B	250	001	3-C12	3790 58 010	203	004	3-C6
0247 56 274A	186	045	3-G2	1819 58 020	203	005	3-C6
3875 56 531	186	040	3-G2	0603 58 110A	203	006	3-C6
3875 56 531A	185	040	3-G2	0115 58 171	203	011	3-C6
0208 56 615	182	028	3-D2	0603 58 210	203	012	3-C6
0208 56 615	186	046	3-G2	0115 58 214	204	018	3-D6

PARTS NUMBER	PARTS COMP. LIST PAGE	FIG. NO.	FICHE INDEX	PARTS NUMBER	PARTS COMP. LIST PAGE	FIG. NO.	FICHE INDEX
0588 58 221B	204	013	3-D6	0223 58 721	210	027	3-I6
0588 58 221C	204	013	3-D6	0187 58 731	210	028	3-I6
1823 58 221A	204	013	3-D6	0603 58 741A	210	029	3-I6
1823 58 221B	204	013	3-D6	0588 58 760	210	026	3-I6
0588 58 231	204	014	3-D6	0603 58 811	210	030	3-I6
0588 58 241	204	015	3-D6	0603 58 812	210	031	3-I6
0100 58 272A	208	001	3-G6	0603 58 820A	210	032	3-I6
0603 58 280A	204	016	3-D6	0603 58 823A	211	036	3-J6
0603 58 290A	204	017	3-D6	0317 58 831A	211	038	3-J6
0603 58 300A	206	002	3-G6	0317 58 832	211	039	3-J6
0259 58 305B	208	006	3-G6	3874 58 901	206	033	3-F6
0118 58 370A01	208	004	3-G6	3874 58 901A	206	033	3-F6
0118 58 391 01	208	005	3-G6	3790 58 910 03	206	035	3-F6
0118 58 391A01	208	005	3-G6	3790 58 910 22	206	035	3-F6
0118 58 392	208	006	3-G6	3790 58 910 52	206	035	3-F6
0603 58 410C	204	017	3-D6	0208 58 921	206	036	3-F6
0603 58 410D	204	017	3-D6	0187 58 922	206	037	3-F6
1823 58 410	204	017	3-D6	0208 58 925	190-1	034	3-E3
1823 58 410A	204	017	3-D6	0118 58 931	179	040	3-H1
0603 58 411B	204	020	3-D6	1854 58 951A	206	038	3-F6
0603 58 411C	205	020	3-E6	0223 58 961	262	002	3-H13
1823 58 411	205	020	3-E6	0223 58 962	262	003	3-H13
1823 58 411A	205	020	3-E6	3790 59 010	203	004	3-C6
0603 58 412A	205	021	3-E6	3790 59 020	203	005	3-C6
0603 58 420B	205	022	3-E6	0603 59 110A	203	006	3-C6
0603 58 430A	205	025	3-E6	0603 59 300A	208	002	3-G6
0183 58 451	205	023	3-E6	0118 59 370A01	208	004	3-G6
0603 58 450A	205	024	3-E6	3875 59 390 50	210	033	3-I6
0187 58 471	205	027	3-E6	0603 59 410C	204	017	3-D6
0193 58 481	205	028	3-E6	0603 59 410D	204	017	3-D6
0603 58 491C	205	030	3-E6	1823 59 410	204	017	3-D6
0208 58 497	206	032	3-F6	1823 59 410A	204	017	3-D6
2651 58 500B	208	007	3-G6	0603 59 412A	205	021	3-E6
0259 58 570	208	011	3-G6	0603 59 420B	205	022	3-E6
0259 58 581	209	012	3-H6	0603 59 430A	205	025	3-E6
2350 58 582	209	013	3-H6	0183 59 451	205	023	3-E6
0187 58 592A	209	014	3-H6	0603 59 460A	205	024	3-E6
2350 58 593	209	017	3-H6	0603 59 491C	206	030	3-F6
2651 58 600	208	008	3-G6	2651 59 500B	208	007	3-G6
0115 58 651B	209	019	3-H6	0259 59 570	209	011	3-H6
2119 58 668	262	001	3-H13	0259 59 581	209	012	3-H6
2651 58 670	209	020	3-H6	0115 59 651B	209	019	3-H6
0603 58 674	209	021	3-H6	3874 59 901	206	033	3-F6
0603 58 675	209	022	3-H6	3874 59 901A	206	033	3-F6
0588 58 710	210	025	3-I6	3790 59 910 03	206	035	3-F6

PARTS NUMBER	PARTS COMP. LIST PAGE	FIG. NO.	FICHE INDEX	PARTS NUMBER	PARTS COMP. LIST PAGE	FIG. NO.	FICHE INDEX
3790 59 910 22	206	035	3-F6	1854 61 190C	215	039	3-E7
3790 59 910 52	206	035	3-F6	1854 61 211	216	051	3-F7
1854 59 951A	206	038	3-F6	1854 61 212	216	053	3-F7
3787 60 050	194	029	3-E4	1854 61 220A	217	064	3-G7
3597 60 053	194	030	3-E4	2677 61 240A	214	032	3-D7
1011 60 070A	194	035	3-E4	2677 61 250A	215	034	3-E7
1011 60 241A	192	012	3-C4	2677 61 250B	215	034	3-E7
0317 60 252	195	054	3-F4	2677 61 260A	215	033	3-E7
0317 60 253	195	055	3-F4	0233 61 479	216	049	3-F7
1634 60 254	195	056	3-F4	2541 61 573A	215	035	3-E7
0317 60 255	195	057	3-F4	0613 63 105A	182	029	3-D2
0317 60 256	195	058	3-F4	1002 64 491	187	051	3-H2
0317 60 257	195	059	3-F4	1854 64 620A	195	047	3-F4
0317 60 258	195	060	3-F4	1854 64 640A	195	048	3-F4
0317 60 259	195	061	3-F4	1854 64 650	195	050	3-F4
0317 60 261	196	062	3-G4	1854 64 660	195	051	3-F4
0317 60 262	196	063	3-G4	3790 65 010	219		3-C8
0866 60 263	196	064	3-G4	3874 65 014	222	038	3-F8
0866 60 264	196	065	3-G4	3874 65 014	222	041	3-F8
0317 60 266	196	066	3-G4	3790 65 020	219	001	3-C8
0866 60 267	196	067	3-G4	0727 65 052A	223	050	3-G8
1907 60 311	194	039	3-E4	0559 65 055	223	048	3-G8
1854 60 331A	194	042	3-E4	2651 65 140A	219	002	3-C8
1854 60 341A	194	043	3-E4	1854 65 201A	219	004	3-C8
0370 60 425A	262	010	3-H13	1854 65 210A	219	005	3-C8
0370 60 500B	262	011	3-H13	1854 65 310	219	006	3-C8
0305 60 690	240	006	3-H10	3790 65 430	219	007	3-C8
0305 60 715	198	097	3-I4	1823 65 437A	219	008	3-C8
0866 60 720A00	195	046	3-F4	3790 65 460	219	010	3-C8
0317 60 721	198	098	3-I4	0603 65 490C	219	011	3-C8
1540 60 930	234	002	3-C10	3790 65 500	219	003	3-C8
3874 60 962	237	050	3-F10	1854 65 531A	219	003	3-C8
8531 60 962	237	050	3-F10	0183 65 551	219	012	3-C8
8531 60 962A	237	050	3-F10	0183 65 552	220	014	3-D8
1708 61 031	182	031	3-D2	0183 65 553	220	015	3-D8
0864 61 061A	046	064	1-G6	0024 65 554	220	016	3-D8
1854 61 080D	213		3-C7	0603 65 560A	220	018	3-D8
1854 61 080E	213		3-C7	0193 65 627	217	068	3-G7
3792 61 140B	213		3-C7	1854 65 711A	222	042	3-F8
3792 61 140C	213		3-C7	1854 65 721	222	043	3-F8
2677 61 145A	214	027	3-D7	1854 65 722	222	044	3-F8
3874 61 155	214	031	3-D7	1854 65 730	222	045	3-F8
1823 61 170C00	215	037	3-E7	0014 65 734	223	049	3-G8
1823 61 180C	215	037	3-E7	1854 65 741	223	046	3-G8
0824 61 183B	217	065	3-G7	3790 65 751	223	052	3-G8

PARTS NUMBER	PARTS COMP. LIST PAGE	FIG. NU.	FICHE INDEX	PARTS NUMBER	PARTS COMP. LIST PAGE	FIG. NU.	FICHE INDEX
3790 65 752	223	053	3-G8	1175 66 710A	262	008	3-H13
1823 65 810C	223	056	3-G8	0223 66 722	242	033	3-J10
1854 65 851B	221	030	3-E8	0603 66 723	240	013	3-H10
1854 65 853	221	031	3-E8	3790 66 730	234	011	3-C10
1854 65 855B	220	021	3-D8	0188 66 731A	240	015	3-H10
1854 65 856	220	022	3-D8	8531 66 760	235	016	3-D10
1854 65 870	222	034	3-F8	1720 66 780B	235	022	3-D10
1823 65 900	220	024	3-D8	1720 66 780C	235	022	3-D10
1854 65 951B	221	030	3-E8	0233 66 790	237	048	3-F10
1854 65 970	222	034	3-F8	1720 66 790B	235	021	3-D10
0183 66 021	225	001	3-C9	1720 66 790C	235	021	3-D10
2801 66 022	225	002	3-C9	1524 66 810	236	026	3-E10
1854 66 031	225	003	3-C9	3919 66 830	236	028	3-E10
1854 66 041	225	003	3-C9	0317 66 862	250	008	3-C12
0136 66 091A	230	015	3-G9	0710 66 868A	240	012	3-H10
2244 66 091	227	029	3-E9	1854 66 870	250	003	3-C12
0136 66 092	230	010	3-G9	1857 66 870	250	003	3-C12
0136 66 094A	231	018	3-H9	1854 66 900	251	009	3-D12
0259 66 094A	227	030	3-E9	1857 66 900	251	009	3-D12
0259 66 095	227	031	3-E9	1854 66 903	251	012	3-D12
2244 66 111	227	029	3-E9	1854 66 905	251	013	3-D12
0259 66 114	227	030	3-E9	0222 66 911	250	002	3-C12
3790 66 120	195	053	3-F4	0208 66 949	242	036	3-J10
3790 66 121	196	068	3-G4	0820 66 950	240	016	3-H10
1011 66 130	235	020	3-D10	0866 66 960	251	014	3-D12
0243 66 152	234	005	3-C10	0866 66 965	251	015	3-D12
2627 66 201A	230	001	3-G9	1010 66 980	252	026	3-E12
2651 66 220A	231	019	3-H9	0820 66 992	251	016	3-D12
0702 66 290	234	004	3-C10	3790 67 010B	241	020	3-I10
1854 66 295	234	007	3-C10	3790 67 030A	241	022	3-I10
1823 66 330A	231	021	3-H9	3790 67 040A	241	023	3-I10
2158 66 350D	245	004	3-C11	3790 67 060A	241	024	3-I10
0212 66 371	245	006	3-C11	3791 67 070	241	025	3-I10
0223 66 371	245	007	3-C11	3775 67 099	235	018	3-D10
0212 66 372	245	008	3-C11	3775 67 099	235	017	3-D10
1015 66 520A	171	028	2-D11	3790 67 100A	242	032	3-J10
1015 66 520B	171	028	2-D11	3790 67 110	242	033	3-J10
0559 66 520C	135	014	2-C6	0316 67 135	241	029	3-I10
0617 66 534	250	004	3-C12	0553 67 143A	240	011	3-H10
0617 66 535	250	005	3-C12	1907 67 151	240	018	3-H10
0617 66 536	250	006	3-C12	1854 67 180A	237	051	3-F10
2627 66 601	240	003	3-H10	1854 67 180B	237	051	3-F10
1650 66 620	237	040	3-F10	3906 67 240	241	031	3-I10
1650 66 621	237	041	3-F10	1823 67 330	246	036	3-D11
1175 66 710	262	008	3-H13	1823 67 350A	245	005	3-C11

PARTS NUMBER	PARTS COMP. LIST		FIG. NO.	FICHE INDEX	PARTS NUMBER	PARTS COMP. LIST		FIG. NO.	FICHE INDEX
	COMP. LIST PAGE	FIG. NO.				COMP. LIST PAGE	FIG. NO.		
1823 67 350B	245	005	3-C11	2850 69 090	256	010	3-D13		
1823 67 351	245	009	3-C11	2850 69 101	256	011	3-D13		
1823 67 352	245	010	3-C11	1823 69 150B31	256	013	3-D13		
1823 67 370A	245	011	3-C11	1823 69 170B31	256	014	3-D13		
1823 67 380	245	012	3-C11	0223 69 181	257	018	3-E13		
1823 67 390	245	013	3-C11	0222 69 190A	256	017	3-D13		
0317 67 480	248	003	3-E11	3874 69 310 31	259	001	3-F13		
0317 67 480A	248	003	3-E11	3790 69 321	259	002	3-F13		
1011 67 510	248	001	3-E11	3790 69 322	259	003	3-F13		
1011 67 511A	248	002	3-E11	0603 69 323A	259	006	3-F13		
1011 67 515	248	004	3-E11	3875 69 370 00	210	033	3-16		
1011 67 515A	248	004	3-E11	3875 69 370 20	210	033	3-16		
0860 67 521	248	005	3-E11	3875 69 370 50	210	033	3-16		
1016 67 620	238	008	1-E2	3875 69 373 00	210	034	3-16		
1016 67 620	238	059	3-G10	3875 69 373 20	210	034	3-16		
3564 67 700	238	055	3-G10	3875 69 373 50	210	034	3-16		
0735 67 730A	238	056	3-G10	3875 69 390 00	210	033	3-16		
1220 67 740	240	009	3-H10	3875 69 390 20	210	033	3-16		
3648 67 740	240	009	3-H10	1854 69 411	259	007	3-F13		
0839 67 880	238	037	3-E10	1854 69 412	259	008	3-F13		
1011 67 911	066	045	1-E8	3792 69 511A06	259	012	3-F13		
1011 67 911	242	036	3-J10	3792 69 521B06	259	013	3-F13		
1011 67 912	242	036	3-J10	1854 69 611A	260	015	3-G13		
1011 67 925	238	057	3-G10	1856 69 611A	260	015	3-G13		
1011 67 925	242	036	3-J10	1854 69 660B	260	016	3-G13		
1220 67 985	240	008	3-H10	1854 69 683	260	018	3-G13		
8715 67 985	240	008	3-H10	1854 69 684B	260	019	3-G13		
0305 67 994	242	036	3-J10	1854 69 685	260	020	3-G13		
0317 68 015A	196	069	3-G4	1854 69 688	260	022	3-G13		
0317 68 015	196	070	3-G4	1854 69 689A	260	023	3-G13		
1854 68 020	196	071	3-G4	0193 69 770A	136	015	2-D6		
0810 68 070A	254	008	3-C13	0600 69 784	136	015	2-D6		
1854 68 091	196	076	3-G4	0727 69 785	136	015	2-D6		
0866 68 095	196	077	3-G4	2651 69 810	257	021	3-E13		
0603 68 240	254	002	3-C13	1879 70 220A	197	085	3-H4		
3792 68 610B	254	003	3-C13	2370 70 231A	197	086	3-H4		
3792 68 615	254	005	3-C13	1854 70 240	197	087	3-H4		
1856 68 860	197	095	3-H4	2370 70 261	197	090	3-H4		
0398 68 875	250	003	3-C12	0317 70 262A	197	092	3-H4		
0730 69 057A	256	001	3-D13	0317 70 269	197	094	3-H4		
1128 69 071A02	256	002	3-D13	0735 70 425A	190-	1 031	3-E3		
1881 69 076	256	003	3-D13	0118 70 531	179	041	3-H1		
1854 69 087A00	257	025	3-E13	0208 70 713	189	011	3-C3		
1854 69 087A02	257	025	3-E13	0118 70 722A	189	012	3-C3		
1854 69 088	257	024	3-E13	0223 70 827	190-	1 037	3-E3		

PARTS NUMBER	PARTS COMP. LIST PAGE	FIG. NO.	FICHE INDEX	PARTS NUMBER	PARTS COMP. LIST PAGE	FIG. NO.	FICHE INDEX
0208 72 821	211	041	3-J6	0866 76 472A	213	006	3-C7
0208 72 822	211	041	3-J6	0866 76 474	213	016	3-C7
1004 72 873	182	032	3-D2	0866 76 475	213	007	3-C7
2119 74 15a	262	012	3-H13	0866 76 476	213	008	3-C7
3775 75 010A	193	015	3-D4	1823 76 554	215	043	3-E7
0326 75 011	193	014	3-D4	1823 76 602	245	014	3-C11
3790 75 021	193	015	3-D4	1823 76 631	246	037	3-D11
0483 75 022	193	016	3-D4	8532 76 641	245	004	3-C11
0317 75 023	193	017	3-D4	8532 76 672	248	008	3-E11
3900 75 023A	193	018	3-D4	1391 76 673	248	007	3-E11
3787 75 026	193	019	3-D4	8527 77 739	006	064	1-G1
3790 75 026	193	019	3-D4	1854 78 615	174	026	3-D1
1568 75 029	193	027	3-D4	1855 78 616	174	031	3-D1
3900 75 030A	193	020	3-D4	1823 76 620B	174	027	3-D1
3900 75 033	193	027	3-D4	1854 78 640	174	028	3-D1
0492 75 060	193	021	3-D4	1854 78 650	174	029	3-D1
0824 75 147	193	022	3-D4	0275 87 007	225	004	3-C9
0824 75 150	193	023	3-D4	0727 87 012	225	006	3-C9
0710 75 436	193	024	3-D4	2850 87 012	225	005	3-C9
1819 75 910	262	006	3-H13	0727 87 013	225	007	3-C9
1819 75 920	262	007	3-H13	0727 87 014	225	008	3-C9
3775 75 980	262	005	3-H13	0727 87 016	225	009	3-C9
0208 76 071	260	029	3-G13	0727 87 022	225	006	3-C9
2677 76 121B	213	001	3-C7	0727 87 023	225	007	3-C9
2677 76 122A	213	002	3-C7	0738 87 061	230	003	3-G9
2677 76 123	213	003	3-C7	0738 87 063	230	004	3-G9
3792 76 124A	213	004	3-C7	0259 87 101A	245	015	3-C11
2677 76 129	213	009	3-C7	0710 87 102	231	022	3-H9
2677 76 130	213	010	3-C7	0259 87 103	245	016	3-C11
3792 76 131	213	011	3-C7	0710 87 103	231	023	3-H9
2677 76 133	213	012	3-C7	0710 87 104	231	024	3-H9
2677 76 134A	213	013	3-C7	2158 87 104	245	017	3-C11
2677 76 135	213	015	3-C7	0259 87 105	246	018	3-D11
2677 76 135B	213	016	3-C7	0259 87 106	246	019	3-D11
2677 76 143	214	017	3-D7	0257 87 107	246	021	3-D11
2677 76 145	214	018	3-D7	0259 87 107	246	022	3-D11
2677 76 146	214	019	3-D7	0257 87 108	246	023	3-D11
2677 76 147A	214	020	3-D7	0259 87 108A	246	025	3-D11
3792 76 150	214	023	3-D7	0259 87 109A	246	026	3-D11
1823 76 442	216	047	3-F7	2158 87 112B	246	027	3-D11
1823 76 443	216	048	3-F7	0259 87 119	246	028	3-D11
1854 76 446	213	040	3-E7	0259 87 120	246	029	3-D11
1823 76 447A	213	041	3-E7	0710 87 126	230	005	3-G9
1854 76 448A	213	042	3-E7	0259 87 134	246	030	3-D11
3792 76 456	213	005	3-C7	0702 87 135	246	031	3-D11

PARTS NUMBER	PARTS COMP. LIST PAGE	FIG. NU.	FICHE INDEX	PARTS NUMBER	PARTS COMP. LIST PAGE	FIG. NU.	FICHE INDEX
0702 87 138	246	032	3-D11	9079 60 820	030	006	1-C4
2244 87 191	226	022	3-D9	9085 71 0135	051	012	1-C7
2244 87 192	226	023	3-D9	9909 60 5008	198	096	3-I4
2244 87 192	231	025	3-H9	9920 32 000	168	029	2-I10
2244 87 194	226	024	3-D9	9922 11 212	039	046	1-E5
2244 87 194	231	029	3-H9	9922 11 610	168	028	2-I10
2244 87 195	226	024	3-D9	9922 11 610	168	042	2-I10
2244 87 195	231	029	3-H9	9922 11 610	176	007	3-E1
2244 87 196	226	025	3-D9	9922 12 012	116	015	2-C5
2244 87 201	232	030	3-19	9922 12 015	137	025	2-E6
2244 87 206	232	031	3-19	9922 12 015	186	037	3-G2
0738 87 803	246	033	3-D11	9922 12 015B	166	012	2-G10
0738 87 804	246	034	3-D11	9922 12 020	152	029	2-D9
0305 87 906	246	035	3-D11	9922 12 020	170	016	2-C11
0727 87 992	248	007	3-E11	9922 13 020	121	004	2-G5
0305 87 993	246	008	3-E11	9922 13 020	121	015	2-G5
0727 87 994	246	009	3-E11	9922 13 020	122	028	2-H3
0727 87 995	246	010	3-E11	9922 13 020	131	038	2-F5
0662 88 024	201	018	3-D5	9922 13 020	220	016	3-D8
3778 89 175	053	040	1-E7	9922 13 025	122	018	2-H3
0706 89 251	098	004	2-C1	9922 13 025	129	022	2-D5
1052 89 411A	154	005	2-E9	9922 13 025	131	043	2-F5
1052 89 411A	155	015	2-F9	9922 14 030	124	013	2-C4
0391 89 435	154	006	2-E9	9922 20 216	052	032	1-D7
0391 89 435	157	011	2-G9	9922 20 216	080	007	1-F9
0317 89 435A	154	007	2-E9	9922 20 610	012	044	1-L1
0317 89 435A	157	012	2-G9	9922 20 610	013	049	1-M1
1854 89 662	227	028	3-E9	9923 00 511	145	014	2-E7
2244 89 663	226	021	3-D9	9923 00 523B	166	011	2-G10
1854 89 664	230	002	3-G9	9923 00 615	166	013	2-G10
3900 89 665	230	014	3-G9	9923 10 620	168	041	2-I10
1854 89 667	227	028	3-E9	9923 10 822	152	028	2-D9
2244 89 668	226	021	3-D9	9923 10 822	168	031	2-I10
2244 89 673	231	027	3-H9	9923 31 225	051	006	1-C7
2244 89 673	231	027	3-H9	9923 60 571	012	036	1-L1
3565 99 100C	007	085	1-H1	9924 61 232	051	007	1-C7
0305 99 178	062	042	1-L7	9925 10 818	220	013	3-D8
3874 99 322	122	024	2-H3	9925 44 014	101	011	2-E1
3874 99 324	122	025	2-H3	9927 60 506	052	028	1-D7
3874 99 354	130	034	2-E5	9927 61 006	078	036	1-E9
3874 99 356	131	039	2-F5	9927 61 008	118	035	2-E3
3792 99 731	190-	032	3-E3	9927 61 208	139	007	2-F6
3792 99 732	190-	035	3-E3	9927 62 008	070	028	1-H8
3792 99 736	190-	033	3-E3	9927 90 803	242	036	3-J10
3792 99 737	190-	036	3-E3	9927 91 105	242	036	3-J10

PARTS NUMBER	PARTS COMP. LIST PAGE	FIG. NO.	FICHE INDEX	PARTS NUMBER	PARTS COMP. LIST PAGE	FIG. NO.	FICHE INDEX
9928 21 700	078	039	1-E9	9934 80 826	163	004	2-E10
9928 21 901	160	015	2-C10	9934 80 826	163	006	2-E10
9928 22 200	214	022	3-D7	9934 80 832	163	005	2-E10
9928 22 200	216	055	3-F7	9934 80 8930	034	013	1-F4
9928 22 201	148	023	2-D8	9938 10 600	078	040	1-E9
9928 22 600	046	065	1-G6	9938 10 800	078	041	1-E9
9928 22 600	216	054	3-F7	9938 11 400	042	014	1-C6
9928 24 309	030	016	1-C4	9938 41 200	005	053	1-F1
9928 24 900	046	063	1-G6	9938 41 200F	043	016	1-D6
9928 25 800	146	020	2-D8	9950 24 000	051	013	1-C7
9928 31 000	034	015	1-F4	9950 24 000	101	008	2-E1
9928 31 000	147	012	2-C8	9950 31 000F	003	031	1-D1
9928 31 000	163	011	2-E10	9950 33 000	015	003	1-C2
9928 31 100	034	016	1-F4	9951 01 000	007	079	1-H1
9928 31 100	147	013	2-C8	9951 11 000	015	004	1-C2
9928 31 100	163	012	2-E10	9951 11 400	005	062	1-F1
9928 31 200	034	017	1-F4	9951 11 600	007	063	1-H1
9928 31 200	163	013	2-E10	9954 10 1101	011	025	1-K1
9928 31 300	045	054	1-F6	9954 10 1201	095	004	1-K10
9928 80 808	194	032	3-E4	9954 10 1601	008	065	1-I1
9928 80 808B	022	007	1-G2	9954 10 1601	038	027	1-D5
9928 81 608	217	066	3-G7	9954 10 1601	083	053	1-I9
9930 52 800	007	078	1-H1	9954 10 2211	052	033	1-D7
9930 63 000	002	017	1-C1	9954 10 2211	080	008	1-F9
9930 63 000	003	033	1-D1	9954 10 2401	008	065	1-I1
9930 70 600	003	052	1-F1	9954 10 350	008	065	1-I1
9930 71 000	013	002	1-C2	9954 10 350	066	037	1-E8
9933 50 4185	245	011	3-E11	9954 12 401	015	010	1-C2
9933 60 6030	147	011	2-C8	9956 21 000	160	006	2-C10
9933 60 8038	162	027	3-D2	9956 21 000	163	016	2-E10
9934 00 4130	016	011	1-E2	9956 21 200	160	008	2-C10
9934 00 4200	032	035	1-E4	9956 21 400	006	063	1-G1
9934 00 4200	032	036	1-E4	9956 21 400	053	040	1-E7
9934 00 4270	016	004	1-E2	9956 21 400	060	017	1-J7
9934 00 4270	018	012	1-E2	9956 21 600	003	034	1-D1
9934 00 6230	032	034	1-E4	9956 21 600	005	054	1-F1
9934 06 0300	147	011	2-C8	9956 21 800	042	015	1-C6
9934 80 6100	035	035	1-G4	9956 22 800	012	041	1-L1
9934 80 6200	147	011	2-C8	9956 40 800	003	035	1-D1
9934 80 628	149	027	2-E8	9956 40 800	053	040	1-E7
9934 80 6290	163	008	2-E10	9956 40 800	051	043	1-H7
9934 80 6340	147	010	2-C8	9956 41 000	007	079	1-H1
9934 80 6570	163	010	2-E10	9956 41 000	015	005	1-C2
9934 80 6930	034	014	1-F4	9956 41 000	053	040	1-E7
9934 80 816	164	034	2-F10	9956 41 000	060	018	1-J7

PARTS NUMBER	PARTS COMP. LIST		FIG. NO.	FICHE INDEX	PARTS NUMBER	PARTS COMP. LIST		FIG. NO.	FICHE INDEX
	NUMBER	PAGE				NUMBER	PAGE		
9956 41 000	078	042	1-E9	9961 12 000	080	017	1-F9		
9956 41 000	155	017	2-F9	9961 12 500	060	019	1-J7		
9956 41 200	078	043	1-E9	9961 12 750	095	014	1-K10		
9956 41 400	002	004	1-C1	9962 03 7314	106	030	2-I1		
9956 41 600	007	084	1-H1	9962 03 7314	126	042	2-E4		
9956 41 600	035	023	1-G4	9963 60 4130	106	030	2-I1		
9956 41 600	045	017	1-D6	9963 60 4130	126	042	2-E4		
9956 41 600	074	033	1-K8	9965 05 5540	106	030	2-I1		
9956 41 800	053	040	1-E7	9965 05 5540	126	042	2-E4		
9957 32 200	057	041	1-H7	9965 53 0010	106	031	2-I1		
9957 32 500	057	043	1-H7	9965 53 0020	106	031	2-I1		
9957 32 500	091	002	1-H10	9965 53 0030	106	031	2-I1		
9957 33 500	055	003	1-F7	9965 53 0040	106	031	2-I1		
9957 41 300	062	049	1-L7	9965 53 0050	106	031	2-I1		
9957 43 000	044	030	1-E6	9965 53 0060	106	031	2-I1		
9957 45 200	099	010	2-D1	9968 11 001	149	028	2-E8		
9957 50 300	145	014	2-E7	9968 11 501	149	029	2-E8		
9957 50 300	166	011	2-G10	9968 11 503	034	018	1-F4		
9957 50 400	166	013	2-G10	9968 20 801	194	036	3-E4		
9957 50 600	106	028	2-I1	9968 22 001	243	036	3-K10		
9957 50 600	145	006	2-E7	9968 41 000	242	036	3-J10		
9957 50 600	151	012	2-C9	9968 60 800	194	037	3-E4		
9957 50 600	171	033	2-D11	9968 61 400	163	014	2-E10		
9957 60 400	189	014	3-C3	9968 62 000	243	036	3-K10		
9957 60 600	200	009	3-C5	9970 08 120	231	025	3-H9		
9957 60 700	201-	1 019	3-E5	9970 11 030	192	007	3-C4		
9957 60 800	040	047	1-F5	9970 11 030	215	038	3-E7		
9957 83 000	256	004	3-D13	9970 12 080	227	026	3-E9		
9958 32 8338	118	032	2-E3	9970 12 080	230	017	3-G9		
9958 61 0207	052	034	1-D7	9970 12 080	232	032	3-I9		
9958 61 0207	080	009	1-F9	9970 14 278	227	032	3-E9		
9960 30 204	124	014	2-C4	9970 14 278	230	006	3-G9		
9960 30 206	125	015	2-D4	9970 13 050	234	006	3-C10		
9960 30 2060	102	016	2-F1	9970 13 050	237	042	3-F10		
9960 63 3070	055	004	1-F7	9970 16 030	192	009	3-C4		
9960 66 2030	099	011	2-D1	9970 16 030	192	011	3-C4		
9960 66 3050	056	034	1-G7	9970 16 030	193	026	3-C4		
9960 66 3440	056	036	1-G7	9970 60 110	235	013	3-D10		
9960 67 2030	044	031	1-E6	9970 60 110	262	009	3-H13		
9961 11 500	058	054	1-I7	9970 60 115	235	013	3-D10		
9961 11 500	091	003	1-H10	9970 90 108	007	082	1-H1		
9961 11 500	105	019	2-H1	9970 90 108	022	006	1-G2		
9961 11 500	154	010	2-E9	9970 90 108	074	031	1-K8		
9961 11 750	060	012	1-F9	9970 90 108	078	044	1-E9		
9961 12 000	011	028	1-K1	9970 90 108	194	038	3-E4		

9974 00 512	215	036	3-E7	9978 60 616	015	015	1-C2
9975 01 0825	128	008	2-C5	9978 60 616	034	011	1-F4
9975 01 1020	099	018	2-D1	9978 60 616	145	004	2-E7
9975 01 1235	222	039	3-F8	9978 60 616	147	008	2-C8
9975 01 1235	222	040	3-F8	9978 60 616	168	040	2-I10
9975 01 1250	124	003	2-C4	9978 60 616	236	037	3-E10
9975 01 1270	124	004	2-C4	9978 60 616	238	036	3-G10
9975 32 1022	110	012	2-D2	9978 60 616B	225	010	3-C9
9975 36 1022	110	012	2-D2	9978 60 620	119	042	2-F3
9975 37 8115	048	010	1-H6	9978 60 620	145	009	2-E7
9976 10 620	209	015	3-H6	9978 60 630	164	026	2-F10
9976 10 630	209	016	3-H6	9978 60 630	236	036	3-E10
9976 10 630	209	018	3-H6	9978 60 635	163	018	2-E10
9976 10 625	211	040	3-J6	9978 60 816	020	010	1-F2
9976 30 610	171	029	2-D11	9978 60 816	045	051	1-F6
9976 40 416	256	015	3-D13	9978 60 816	136	019	2-D6
9976 40 416	256	016	3-D13	9978 60 816	235	023	3-D10
9976 90 416	174	025	3-D1	9978 60 820	147	002	2-C6
9976 90 425B	174	025	3-D1	9978 60 825	173	011	3-C1
9976 90 616B	190	026	3-D3	9978 60 845	168	043	2-I10
9976 90 616B	222	035	3-F8	9978 60 850	065	019	1-D8
9977 20 410	203	026	3-E6	9978 90 820F	101	002	2-E1
9977 20 514	206	031	3-F6	9979 40 616	245	003	3-C11
9977 20 516	256	012	3-D13	9979 40 825B	119	045	2-F3
9977 30 420	227	027	3-E9	9979 40 830	133	005	2-G5
9977 30 420	232	035	3-I9	9979 50 816	221	026	3-E8
9978 10 820	037	045	1-H7	9979 50 820	221	025	3-E6
9978 10 822	118	034	2-E3	9979 51 032	151	013	2-C9
9978 11 025	174	030	3-D1	9979 60 608	053	037	1-E7
9978 11 240	129	018	2-D5	9979 60 610	004	038	1-E1
9978 11 250	129	019	2-D5	9979 60 610	031	027	1-D4
9978 41 016	076	005	1-C9	9979 60 610	031	031	1-D4
9978 41 020	135	007	2-C6	9979 60 610	034	006	1-F4
9978 50 512	236	027	3-E10	9979 60 610	074	027	1-K8
9978 50 645	167	018	2-H10	9979 60 610	076	008	1-C9
9978 60 510	251	019	3-D12	9979 60 610	076	010	1-C9
9978 60 512	189	016	3-C3	9979 60 610	077	029	1-D9
9978 60 520	216	046	3-F7	9979 60 610	083	054	1-I9
9978 60 612	022	003	1-G2	9979 60 610	160	012	2-C10
9978 60 612	035	021	1-G4	9979 60 610	186	050	3-G2

PARTS NUMBER	PARTS COMP. LIST PAGE	FIG. NO.	FICHE INDEX	PARTS NUMBER	PARTS COMP. LIST PAGE	FIG. NO.	FICHE INDEX
9979 60 610	234	003	3-C10	9979 61 050	077	024	1-D9
9979 60 610	236	060	3-C10	9979 61 090	049	017	1-16
9979 60 612	052	021	1-D7	9979 68 112	111	022	2-E2
9979 60 612	061	031	1-K7	9979 70 510	215	045	3-E7
9979 60 612	080	004	1-F9	9979 70 512	148	026	2-D8
9979 60 612	136	021	2-D6	9979 70 512	231	026	3-H9
9979 60 612	143	027	2-D7	9979 70 516	177	024	3-F1
9979 60 612	161	012	3-C2	9979 70 516B	235	019	3-D10
9979 60 612	181	015	3-C2	9979 70 616	240	010	3-H10
9979 60 612	186	050	3-G2	9980 01 0115	070	021	1-H8
9979 60 616	037	015	1-C5	9980 10 810B	119	044	2-F3
9979 60 616	037	039	1-E5	9980 10 816	136	016	2-D6
9979 60 616	176	005	3-E1	9980 10 816	142	004	2-C7
9979 60 616	221	032	3-E8	9980 10 816	148	016	2-D8
9979 60 616	222	036	3-F8	9980 10 816	201	017	3-D5
9979 60 616	223	047	3-G8	9980 10 820	006	073	1-G1
9979 60 620	044	039	1-E6	9980 10 820	010	007	1-J1
9979 60 620	045	045	1-F6	9980 10 820	139	008	2-F6
9979 60 620	052	024	1-D7	9980 10 820	147	003	2-C8
9979 60 620	076	038	1-E9	9980 10 822	130	031	2-E5
9979 60 625	160	019	2-C10	9980 10 825	011	030	1-K1
9979 60 812	015	012	1-C2	9980 10 830	142	002	2-C7
9979 60 812	016	024	1-D2	9980 10 840	005	057	1-F1
9979 60 812	018	005	1-E2	9980 10 865	005	058	1-F1
9979 60 812	031	028	1-D4	9980 10 875	005	059	1-F1
9979 60 812	031	032	1-D4	9980 10 890	152	020	2-D9
9979 60 812	042	013	1-C6	9980 11 032	073	022	1-J8
9979 60 812	046	060	1-G6	9980 11 045	142	014	2-C7
9979 60 812	160	017	2-C10	9980 11 075	073	023	1-J8
9979 60 812	214	029	3-D7	9980 30 8100	030	003	1-C4
9979 60 814	030	005	1-C4	9980 31 0120	073	023	1-J8
9979 60 816	004	042	1-E1	9980 60 510	246	020	3-D11
9979 60 816	061	026	1-K7	9980 60 610	135	013	2-C6
9979 60 816	075	011	1-C9	9980 60 612	053	039	1-E7
9979 60 820	044	032	1-E6	9980 60 612	257	023	3-E13
9979 60 820	070	025	1-H8	9980 60 614	045	044	1-F6
9979 60 820	201-	021	3-E5	9980 60 614	181	003	3-C2
9979 60 822	061	026	1-K7	9980 60 616	006	068	1-G1
9979 60 825	070	024	1-H8	9980 60 616	038	020	1-D5
9979 60 832	061	029	1-K7	9980 60 616	042	012	1-C6
9979 61 016	171	027	2-D11	9980 60 616	174	019	3-D1
9979 61 035	049	016	1-16	9980 60 616	257	022	3-E13
9979 61 035	077	024	1-D9	9980 60 620	262	012	3-H13
9979 61 045	049	015	1-16	9980 60 630	136	017	2-D6
9979 61 045	077	024	1-D9	9981 11 010	004	039	1-E1

PARTS NUMBER	PARTS COMP. LIST PAGE	FIG. NO.	FICHE INDEX	PARTS NUMBER	PARTS COMP. LIST PAGE	FIG. NO.	FICHE INDEX
9986 30 512	259	005	3-F13	9990 60 600	135	014	2-C6
9986 30 520	196	079	3-G4	9990 60 600	136	017	2-D6
9986 40 408	219	009	3-L8	9990 60 600	167	027	2-H10
9986 40 312	196	073	3-G4	9990 60 600	177	022	3-F1
9986 40 512	223	055	3-G8	9990 60 600	178	027	3-G1
9986 40 520B	193	028	3-D4	9990 60 600	203	002	3-C6
9986 50 408	240	017	3-H10	9990 60 600	209	023	3-H6
9986 50 412	237	044	3-F10	9990 60 600	211	037	3-J6
9986 50 412	240	004	3-H10	9990 60 600	220	023	3-D8
9986 50 510	067	046	1-F8	9990 60 600	231	020	3-H9
9986 50 510	179	039	3-H1	9990 60 800	158	022	2-H9
9986 50 512	167	052	3-H2	9990 60 800	221	025	3-E8
9986 50 516	046	058	1-G6	9990 60 800	221	027	3-E8
9986 50 516	171	022	2-D11	9990 70 600	039	037	1-E5
9986 80 416	170	013	2-C11	9990 70 600	203	003	3-C6
9988 51 040	124	005	2-C4	9991 00 403	174	023	3-D1
9989 60 400	174	025	3-D1	9991 00 601	190	026	3-D3
9989 60 500	192	005	3-C4	9991 00 601	222	037	3-F8
9989 60 500	194	028	3-E4	9991 10 600	135	013	2-C6
9989 60 500	196	074	3-G4	9992 11 000	114	020	2-G2
9989 60 500	196	080	3-G4	9992 11 000	118	037	2-E5
9990 10 800	027	067	1-F3	9992 11 000	122	020	2-H3
9990 10 800	038	026	1-D5	9992 11 000	130	030	2-E5
9990 10 800	044	033	1-E6	9992 11 000	133	010	2-G5
9990 10 800	044	037	1-E6	9992 11 000	139	002	2-F6
9990 10 800	073	024	1-J8	9992 11 000	139	004	2-F6
9990 10 800	101	009	2-E1	9992 11 000	139	010	2-F6
9990 10 800	142	003	2-C7	9992 11 000	152	023	2-D9
9990 10 800	142	006	2-C7	9992 11 000	223	057	3-G8
9990 10 800	142	013	2-C7	9992 11 200	129	016	2-D5
9990 10 800	201-	022	3-E5	9992 11 200	129	018	2-D5
9990 10 800	220	017	3-D8	9992 11 200	129	019	2-D5
9990 10 800	223	051	3-G8	9992 11 400	113	003	2-F2
9990 20 800	171	038	2-D11	9992 11 400	113	009	2-F2
9990 20 800	177	018	3-F1	9992 12 000	118	040	2-E5
9990 30 800	137	023	2-E6	9992 20 600	152	030	2-D9
9990 30 800	186	037	3-G2	9992 21 000	114	020	2-G2
9990 60 400	227	027	3-E9	9992 21 000	118	029	2-E3
9990 60 400	232	033	3-19	9992 21 000	124	006	2-C4
9990 60 500	065	018	1-D8	9992 21 000	130	030	2-E5
9990 60 500	069	019	1-G8	9992 21 000	133	010	2-G5
9990 60 500	177	024	3-F1	9992 21 000	151	013	2-C9
9990 60 500	228	033	3-F9	9992 21 000	167	020	2-H10
9990 60 500	254	004	3-C13	9992 21 200	037	007	1-C5
9990 60 600	052	027	1-D7	9992 21 400	095	002	1-K10

PARTS NUMBER	PARTS COMP. LIST PAGE	FIG. NO.	FICHE INDEX	PARTS NUMBER	PARTS COMP. LIST PAGE	FIG. NO.	FICHE INDEX
9992 21 600	122	022	2-H3	9994 01 000	171	025	2-D11
9992 21 800	099	012	2-D1	9994 01 001	049	018	1-I6
9992 31 400	131	043	2-F5	9994 01 001	052	017	1-D7
9992 41 200	121	004	2-G3	9994 01 001	070	022	1-H8
9992 41 200	121	015	2-G3	9994 01 001	077	025	1-D9
9992 41 200	122	028	2-H3	9994 01 001	099	015	2-D1
9992 41 200	131	038	2-F5	9994 01 200	222	039	3-F8
9992 41 400	122	018	2-H3	9994 01 200	222	040	3-F8
9992 41 400	129	022	2-D5	9994 10 801	020	011	1-F2
9992 80 800	128	007	2-C5	9994 21 000	104	006	2-G1
9992 80 800	128	009	2-C5	9994 21 000	124	008	2-C4
9992 81 200	114	014	2-G2	9994 21 200	124	003	2-C4
9994 00 500	230	007	3-G9	9994 21 200	124	004	2-C4
9994 00 500	251	016	3-D12	9994 41 600	122	023	2-H3
9994 00 500	256	005	3-D13	9994 50 600	200	009	3-C5
9994 00 502	174	017	3-D1	9994 81 200	116	013	2-C3
9994 00 502	196	075	3-G4	9994 90 800	143	018	2-D7
9994 00 600	016	025	1-D2	9995 10 618	167	018	2-H10
9994 00 600	034	004	1-F4	9995 10 618	174	016	3-D1
9994 00 600	045	050	1-F6	9995 10 618	203	009	3-C6
9994 00 600	067	048	1-F8	9995 10 816	044	032	1-E6
9994 00 600	105	023	2-H1	9995 10 822	119	045	2-F3
9994 00 600	145	012	2-E7	9995 10 822	142	002	2-C7
9994 00 601	030	011	1-C4	9995 10 822	142	003	2-C7
9994 00 601	236	029	3-E10	9995 10 822	143	018	2-D7
9994 00 602	074	028	1-K8	9995 10 822	200	002	3-C5
9994 00 602	173	007	3-C1	9995 11 022	118	037	2-E3
9994 00 602	173	013	3-C1	9995 11 022	135	007	2-C6
9994 00 602	174	019	3-D1	9995 11 022	174	030	3-D1
9994 00 602	181	003	3-C2	9995 11 030	137	025	2-E6
9994 00 602	217	067	3-G7	9995 11 030	139	004	2-F6
9994 00 603	066	038	1-E8	9995 11 030	139	010	2-F6
9994 00 800	016	026	1-D2	9995 11 030	139	011	2-F6
9994 00 800	136	019	2-D6	9995 11 030	185	032	3-F2
9994 00 800	142	012	2-C7	9995 11 030	223	037	3-G8
9994 00 800	148	016	2-D8	9995 11 030B	119	046	2-F3
9994 00 800	152	021	2-D9	9995 11 226	173	010	3-C1
9994 00 800	152	026	2-D9	9995 20 400	197	083	3-H4
9994 00 800	154	008	2-E9	9995 20 412	062	050	1-L7
9994 00 800	158	023	2-H9	9995 20 500	065	018	1-D8
9994 00 800	214	030	3-D7	9995 20 500	070	019	1-H8
9994 00 801	015	008	1-C2	9995 20 500	148	026	2-D8
9994 00 801	158	024	2-H9	9995 20 500	168	038	2-I10
9994 00 802	020	009	1-F2	9995 20 500	177	024	3-F1
9994 00 802	147	004	2-C8	9995 20 500	192	004	3-C4

PARTS NUMBER	PARTS COMP. LIST PAGE	FIG. NO.	FICHE INDEX	PARTS NUMBER	PARTS COMP. LIST PAGE	FIG. NO.	FICHE INDEX
9995 20 500	211	035	3-J6	9995 20 800	201- 1	021	3-E5
9995 20 500	215	045	3-E7	9995 20 800	220	017	3-D8
9995 20 500	228	033	3-F9	9995 20 800	221	025	3-E8
9995 20 500	235	019	3-D10	9995 20 800	221	026	3-E8
9995 20 500	254	004	3-C13	9995 20 800	221	027	3-E8
9995 20 500	259	005	3-F13	9995 20 816	171	034	2-D11
9995 20 500B	193	028	3-D4	9995 20 816	200	009	3-C0
9995 20 500B	197	093	3-H4	9995 20 822	020	010	1-F2
9995 20 516	231	026	3-H9	9995 20 822	070	025	1-H8
9995 20 516	250	007	3-C12	9995 20 822	152	020	2-D9
9995 20 600	015	015	1-C2	9995 20 822	152	021	2-D9
9995 20 600	034	004	1-F4	9995 20 878	046	060	1-G6
9995 20 600	034	011	1-F4	9995 21 000	152	022	2-D9
9995 20 600	045	044	1-F6	9995 21 000	152	023	2-D9
9995 20 600	135	013	2-C6	9995 21 000	167	020	2-H10
9995 20 600	177	022	3-F1	9995 21 000	223	057	3-G8
9995 20 600	178	027	3-G1	9995 21 030	173	011	3-C1
9995 20 600	206	010	3-G6	9995 21 030	200	002	3-C5
9995 20 600	210	023	3-I6	9995 21 030	223	047	3-G8
9995 20 600	210	024	3-I6	9995 21 442	140	012	2-G6
9995 20 600	236	027	3-E10	9995 30 300	116	012	2-C3
9995 20 600	236	036	3-E10	9995 30 400	039	045	1-E5
9995 20 600	240	010	3-H10	9995 30 500	178	033	3-G1
9995 20 600	262	012	3-H13	9995 30 600	167	017	2-H10
9995 20 618	119	042	2-F3	9995 30 600	176	005	3-E1
9995 20 618	135	014	2-C6	9995 30 600	181	003	3-C2
9995 20 618	143	027	2-D7	9995 30 600	190	020	3-D3
9995 20 618	145	009	2-E7	9995 30 600	220	023	3-D8
9995 20 618	186	050	3-G2	9995 30 600	225	010	3-C9
9995 20 618	203	010	3-C6	9995 30 600	236	029	3-E10
9995 20 618	223	047	3-G8	9995 30 600	236	037	3-E10
9995 20 618B	222	035	3-F8	9995 30 600	238	058	3-G10
9995 20 800	005	057	1-F1	9995 30 600	245	003	3-C11
9995 20 800	005	058	1-F1	9995 30 800	038	026	1-D5
9995 20 800	005	059	1-F1	9995 30 800	044	033	1-E6
9995 20 800	006	073	1-G1	9995 30 800	171	035	2-D11
9995 20 800	030	003	1-C4	9995 31 000	048	002	1-H6
9995 20 800	045	051	1-F6	9995 31 000	073	023	1-J8
9995 20 800	057	045	1-H7	9995 31 400	171	024	2-D11
9995 20 800	073	024	1-J8	9995 81 018	110	013	2-D2
9995 20 800	136	019	2-D6	9995 81 022	128	012	2-C5
9995 20 800	139	008	2-F6	9996 33 310	062	045	1-L7
9995 20 800	147	003	2-C8	9996 33 330	062	045	1-L7
9995 20 800	148	016	2-D8	9996 36 910	055	002	1-F7
9995 20 800	201	017	3-D5	9996 36 930	055	002	1-F7

PARTS NUMBER	PARTS COMP. LIST PAGE	FIG. NO.	FICHE INDEX	PARTS NUMBER	PARTS COMP. LIST PAGE	FIG. NO.	FICHE INDEX
9996 70 500B	198	096	3-14	9997 10 600	225	010	3-C9
9996 80 400B	259	014	3-F13	9997 10 600	231	020	3-H9
9997 10 300	116	012	2-C3	9997 10 600	240	010	3-H10
9997 10 400	039	032	1-E5	9997 10 600	245	003	3-C11
9997 10 400	105	022	2-H1	9997 10 600	257	022	3-E13
9997 10 400	197	083	3-H4	9997 10 600	257	023	3-E13
9997 10 400	205	029	3-E6	9997 10 600	262	012	3-H13
9997 10 400	214	021	3-D7	9997 10 601	060	001	1-J7
9997 10 400B	194	044	3-E4	9997 10 601	061	036	1-K7
9997 10 500	065	018	1-D8	9997 10 800	005	057	1-F1
9997 10 500	070	019	1-H8	9997 10 800	005	056	1-F1
9997 10 500	148	026	2-D8	9997 10 800	005	059	1-F1
9997 10 500	156	038	2-110	9997 10 800	006	075	1-G1
9997 10 500	177	024	3-F1	9997 10 800	010	007	1-J1
9997 10 500	176	033	3-G1	9997 10 800	011	030	1-K1
9997 10 500	215	045	3-E7	9997 10 800	027	067	1-F3
9997 10 500	246	024	3-D11	9997 10 800	030	003	1-C4
9997 10 500	250	007	3-C12	9997 10 800	038	026	1-D5
9997 10 500	254	004	3-C13	9997 10 800	044	033	1-E6
9997 10 500	259	003	3-F13	9997 10 800	044	037	1-E6
9997 10 500B	197	093	3-H4	9997 10 800	048	009	1-H6
9997 10 600	006	008	1-C1	9997 10 800	048	010	1-H6
9997 10 600	038	020	1-D5	9997 10 800	073	024	1-J8
9997 10 600	039	037	1-E5	9997 10 800	101	009	2-E1
9997 10 600	042	012	1-C6	9997 10 800	107	035	2-J1
9997 10 600	045	044	1-F6	9997 10 800	116	013	2-C3
9997 10 600	052	027	1-D7	9997 10 800	118	034	2-E3
9997 10 600	053	039	1-E7	9997 10 800	119	044	2-F3
9997 10 600	066	040	1-E8	9997 10 800	119	045	2-F3
9997 10 600	121	006	2-G3	9997 10 800	128	007	2-C5
9997 10 600	135	013	2-C6	9997 10 800	128	009	2-C5
9997 10 600	136	017	2-D6	9997 10 800	130	031	2-E5
9997 10 600	147	008	2-C8	9997 10 800	133	005	2-G5
9997 10 600	167	017	2-H10	9997 10 800	136	016	2-D6
9997 10 600	167	018	2-H10	9997 10 800	136	019	2-D6
9997 10 600	176	005	3-E1	9997 10 800	139	008	2-F6
9997 10 600	178	027	3-G1	9997 10 800	142	002	2-C7
9997 10 600	181	003	3-C2	9997 10 800	142	004	2-C7
9997 10 600	201	009	3-D5	9997 10 800	142	008	2-C7
9997 10 600	203	009	3-C6	9997 10 800	147	003	2-C8
9997 10 600	208	003	3-G6	9997 10 800	148	016	2-D8
9997 10 600	208	010	3-G6	9997 10 800	158	022	2-H9
9997 10 600	210	023	3-I6	9997 10 800	171	038	2-D11
9997 10 600	210	024	3-I6	9997 10 800	201	017	3-D5
9997 10 600	211	037	3-J6	9997 10 800	201- 1	022	3-E5

PARTS NUMBER	PARTS COMP. LIST PAGE	FIG. NO.	FICHE INDEX	PARTS NUMBER	PARTS COMP. LIST PAGE	FIG. NO.	FICHE INDEX
9997 10 800	220	017	3-D8	9997 40 600	209	015	3-H6
9997 10 800	220	019	3-D8	9997 40 600	209	016	3-H6
9997 10 800	220	020	3-D8	9997 40 600	209	018	3-H6
9997 10 800	221	025	3-E8	9997 50 400	257	020	3-E13
9997 10 800	221	027	3-E8	9997 50 500	178	032	3-G1
9997 10 800	223	051	3-G8	9997 50 600	209	015	3-H6
9997 11 000	004	039	1-E1	9997 50 600	209	016	3-H6
9997 11 000	006	070	1-G1	9997 50 800	176	006	3-E1
9997 11 000	048	002	1-H6	9997 50 800	176	009	3-E1
9997 11 000	073	023	1-J8	9997 50 800	211	040	3-J6
9997 11 000	099	018	2-D1	9997 71 845	124	010	2-C4
9997 11 000	113	004	2-F2	9997 91 200	037	007	1-C5
9997 11 000	118	037	2-E3				
9997 11 000	122	020	2-H3				
9997 11 000	125	024	2-D4				
9997 11 000	128	012	2-C5				
9997 11 000	139	002	2-F6				
9997 11 000	139	004	2-F6				
9997 11 000	139	010	2-F6				
9997 11 000	140	011	2-G6				
9997 11 000	143	015	2-D7				
9997 11 000	152	023	2-D9				
9997 11 000	167	020	2-H10				
9997 11 000	174	030	3-B1				
9997 11 000	223	037	3-G8				
9997 11 200	109	009	2-C2				
9997 11 200	114	014	2-G2				
9997 11 200	123	025	2-D4				
9997 11 200	129	016	2-D5				
9997 11 200	129	018	2-D5				
9997 11 200	129	019	2-D5				
9997 11 200	173	010	3-C1				
9997 11 400	095	002	1-K10				
9997 11 400	113	003	2-F2				
9997 11 400	113	009	2-F2				
9997 11 800	099	013	2-D1				
9997 12 000	118	040	2-E3				
9997 20 800	151	011	2-C9				
9997 20 800	171	036	2-D11				
9997 20 800	177	022	3-F1				
9997 21 000	204	019	3-D6				
9997 30 400	197	089	3-H4				
9997 40 500	203	007	3-C6				
9997 40 600	203	010	3-C6				
9997 40 600	208	009	3-G6				