

# BRAKES

## CONVENTIONAL BRAKE SYSTEM LOCATION INDEX

(w)

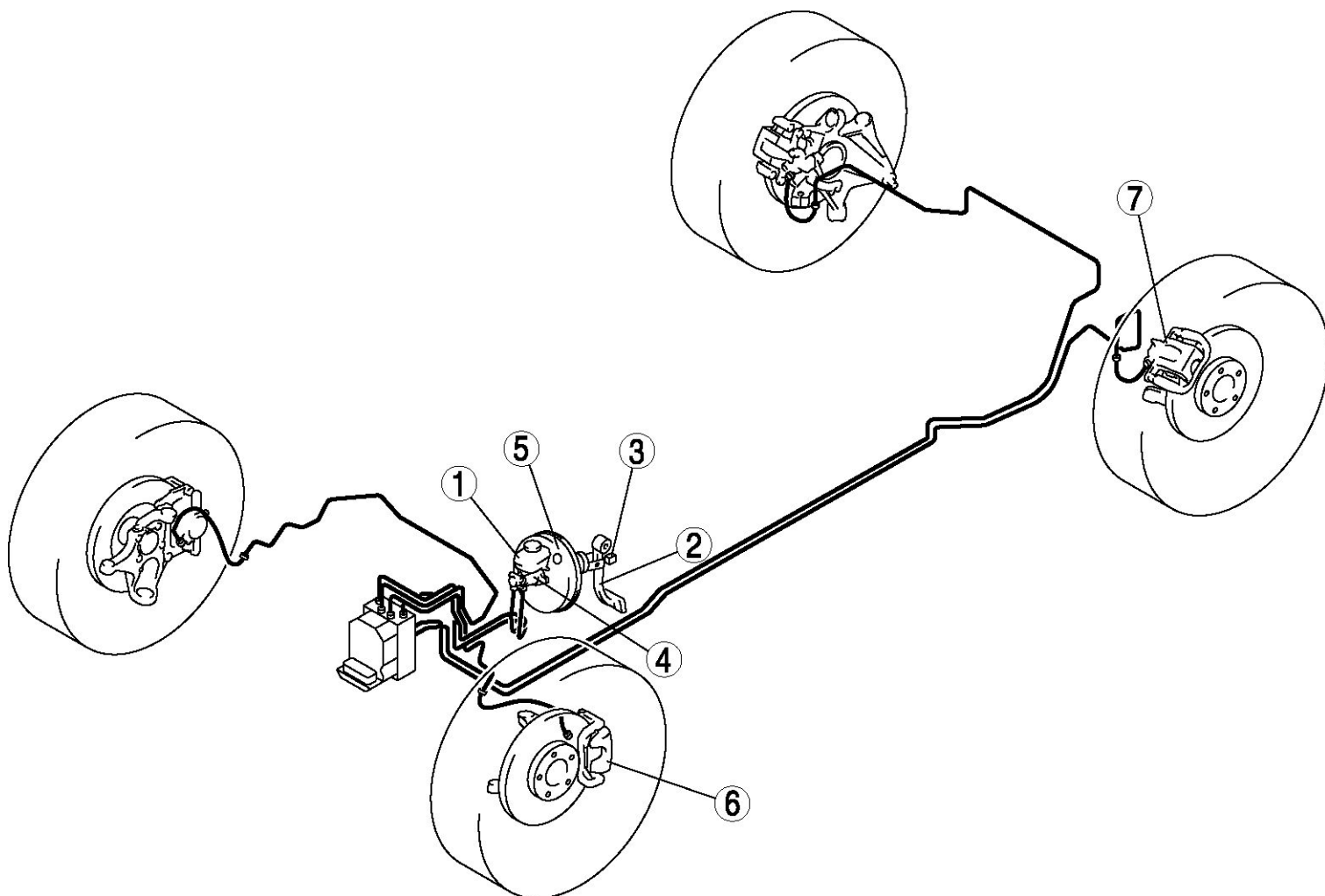

1	Brake fluid
2	Brake pedal
3	Brake switch
4	Master cylinder
5	Power brake unit
6	Front brake (disc)
7	Rear brake (disc)

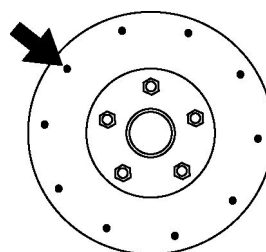

(w)

# CONVENTIONAL BRAKE SYSTEM

## AIR BLEEDING

### CAUTION:

- Brake fluid will damage painted surfaces. Be careful not to spill any on painted surfaces. If it is spilled, wipe it off immediately.

### NOTE:

- Keep the fluid level in the reserve tank at 3/4 full or more during the air bleeding.
- Begin air bleeding with the master cylinder and then continue with the brake caliper that is furthest away from the master cylinder. Finish by bleeding air from the master cylinder again.

### Specified fluid

- SAE J1703, FMVSS 116 DOT-3
1. Remove the bleeder cap from the brake caliper, and connect a vinyl tube to the bleeder screw.
  2. Place the other end of the vinyl tube in a clear container, and fill the container with fluid during air bleeding.
  3. Working with two people, one should depress the brake pedal a few times and then depress and hold the pedal down.
  4. While the brake pedal is being held down, the other person should loosen the bleeder screw using the SST, and bleed any fluid containing air bubbles. Once completed, tighten the bleeder screw.

### Tightening torque

- 6.9—9.8 N·m {71—99 Kgf·cm, 62—86 in·lbf}

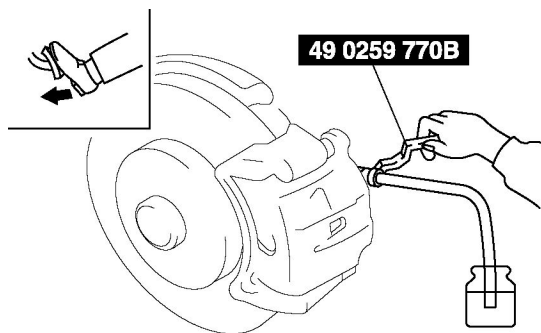

5. Repeat Steps 3 and 4 until no air bubbles are seen.
6. Perform air bleeding as described in the above procedures for all brake calipers.
7. After air bleeding, inspect the following:
  - Brake operation
  - Fluid leakage
  - Fluid level

# VACUUM LINE

## VACUUM LINE INSPECTION

1. Remove the vacuum hose between the power brake unit and the intake manifold using pliers.
2. Verify that air can be blown from the power brake unit side of the vacuum hose towards the intake manifold side, and that air cannot be blown in the opposite direction.
  - If there is any malfunction of the inner check valve, replace it together with the vacuum hose as a single unit.

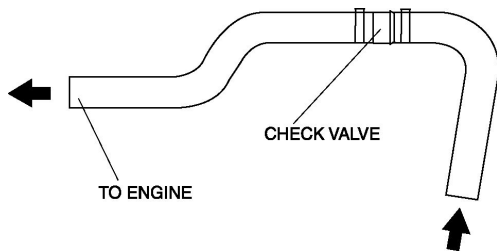

# BRAKE PEDAL

## BRAKE PEDAL INSPECTION

### Brake Pedal Height Inspection

1. Measure the distance from the center of the upper surface of the pedal pad to the insulator and verify that it is as specified.

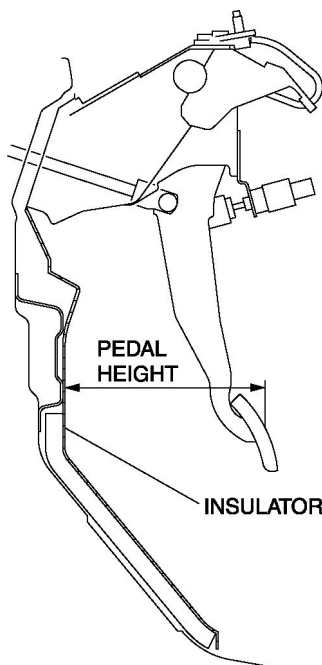

- If not within the specification, adjust the pedal height.

### Pedal height (reference value)

- 175 mm {6.89 in}

## Brake Pedal Height Adjustment

### CAUTION:

- The brake switch may not operate normally after adjusting the pedal height. Whenever adjusting the pedal height, replace the brake switch with a new one.
  - The interlock cable may not operate normally after adjusting the pedal height. Whenever adjusting the pedal height, refer to the interlock cable installation note. (See [Interlock Cable Installation Note](#).)
1. Loosen the locknut and turn the push rod to adjust the pedal height.

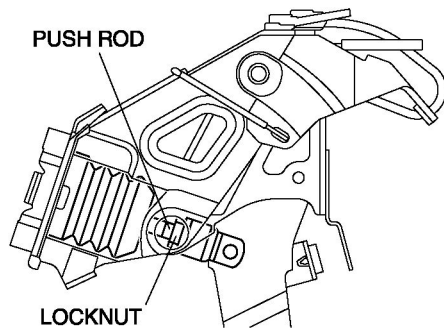

2. Tighten the locknut.

### Tightening torque

- 15.7—21.6 N·m {1.61—2.20 Kgf·m, 11.6—15.9 ft·lbf}
3. After adjustment, inspect the pedal play.

## Brake Pedal Play Inspection

1. Depress the pedal several times to release the vacuum in the power brake unit.
2. Gently depress the pedal by hand, and measure the pedal play.
  - If not within the specification, inspect the wear of the clevis pin and replace it if there is any malfunction.

### Standard pedal play

- 2—5 mm {0.08—0.19 in}

### NOTE:

- If there is no malfunction in the clevis pin, there is a possibility that the power brake unit has some malfunction. Verify that there are no malfunctions, and replace it if necessary.

## Pedal-to-floor Clearance Inspection

1. Start the engine and depress the pedal with a pedal force of **147 N {15.0 Kgf, 33.0 lbf}** .
2. Measure the distance between the pedal pad center and the insulator, and verify that it is as specified.



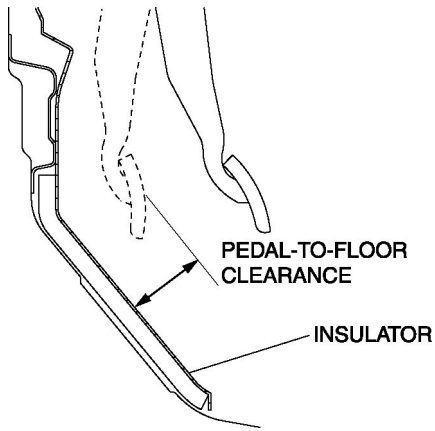

- If the pedal-to-floor clearance is less than the specification, check for air in the brake system.

### Standard pedal-to-floor clearance

- 98.6 mm {3.88 in} or more

## BRAKE PEDAL REMOVAL/INSTALLATION

### CAUTION:

- The clearance between the brake switch and the brake pedal is automatically adjusted to the correct amount when the brake switch connector is connected after the brake switch has been properly installed. If the brake switch is not properly installed or the connector is connected before installation, the clearance may be incorrect, causing a brake light malfunction. Therefore, always verify that the brake switch is properly installed before connecting the connector.
- Once the brake switch clearance has automatically been adjusted, it cannot be adjusted again. Therefore, replace the switch with a new one when replacing the power brake unit or the pedal, or performing any procedure that changes the pedal stroke.
- When replacing the brake pedal (AT), it is possible that the installation of the interlock cable could become defective. Always refer to the interlock cable installation note when replacing the brake pedal. (See [Interlock Cable Installation Note](#).)

### NOTE:

- When the brake switch connector is connected to the brake switch, the clearance between the pedal and the brake switch is adjusted automatically. However, this mechanism will only function one time.
1. Remove in the order indicated in the table.
  2. Install in the reverse order of removal.

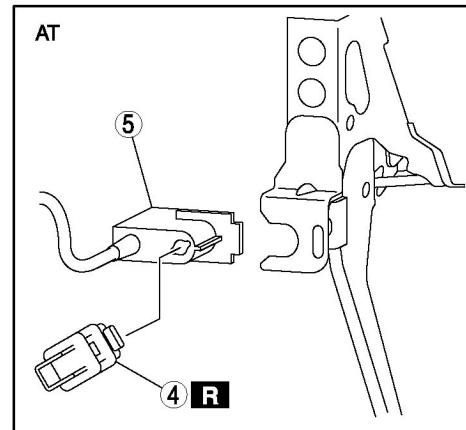
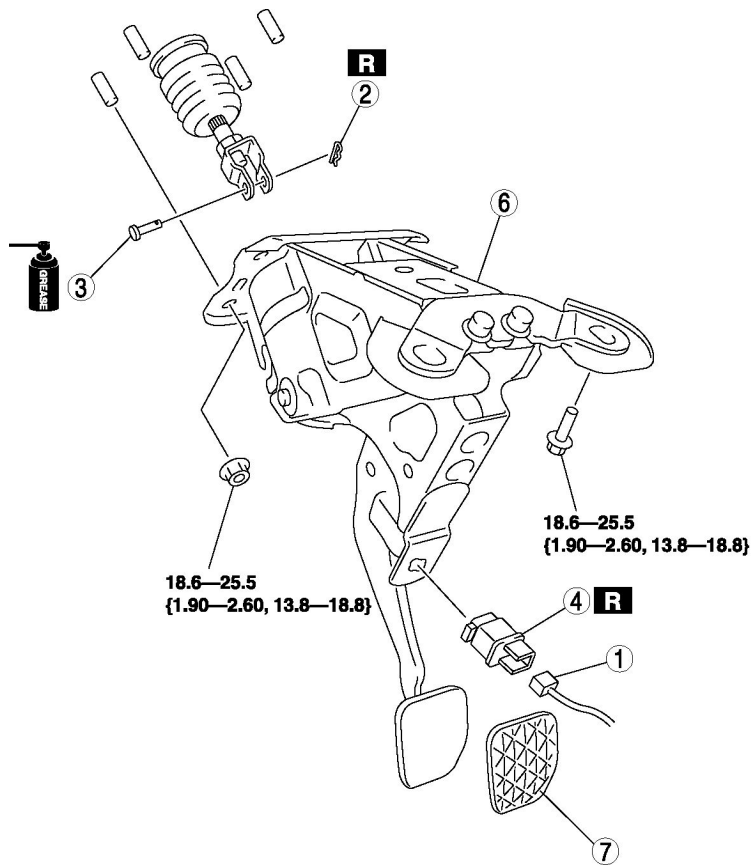

N-m {kgf-m, ft-lbf}

1	Brake switch connector
2	Snap pin
3	Clevis pin
4	Brake switch
5	Interlock cable (AT)
6	Brake pedal
7	Pedal pad

### Brake Switch Installation Note

1. Install the new brake switch to the brake pedal (MT) or the interlock cable (AT), and secure it by turning it clockwise  $45^\circ$  (AT) or counterclockwise  $45^\circ$  (MT).

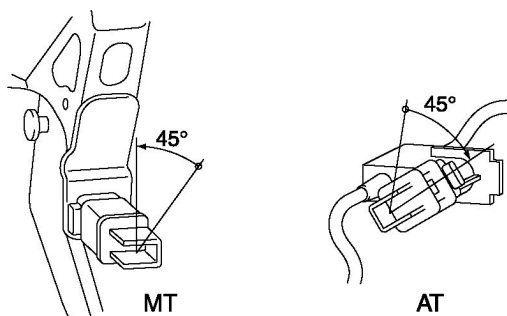

## Brake Switch Connector Installation Note

1. Inspect the brake pedal.
2. With the brake pedal in its original position, install the brake switch to the brake switch connector.

# BRAKE SWITCH

## BRAKE SWITCH INSPECTION

### CAUTION:

- If the brake switch is removed from the brake pedal or the interlock unit, its proper functioning cannot be guaranteed when reinstalled. Therefore, inspect the brake switch with it still installed, or replace the brake switch if it is removed.
1. Verify continuity as indicated in the table.
    - If not as indicated in the table, replace the brake switch.

○—○ : Continuity

Condition	Terminal			
	A	B	C	D
When the brake pedal is depressed		○—○		○
When the brake pedal is not depressed	○—○		○	

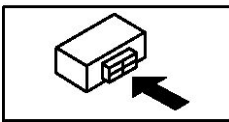
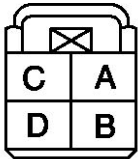

# MASTER CYLINDER

## MASTER CYLINDER REMOVAL/INSTALLATION

1. Remove in the order indicated in the table.
2. Install in the reverse order of removal.

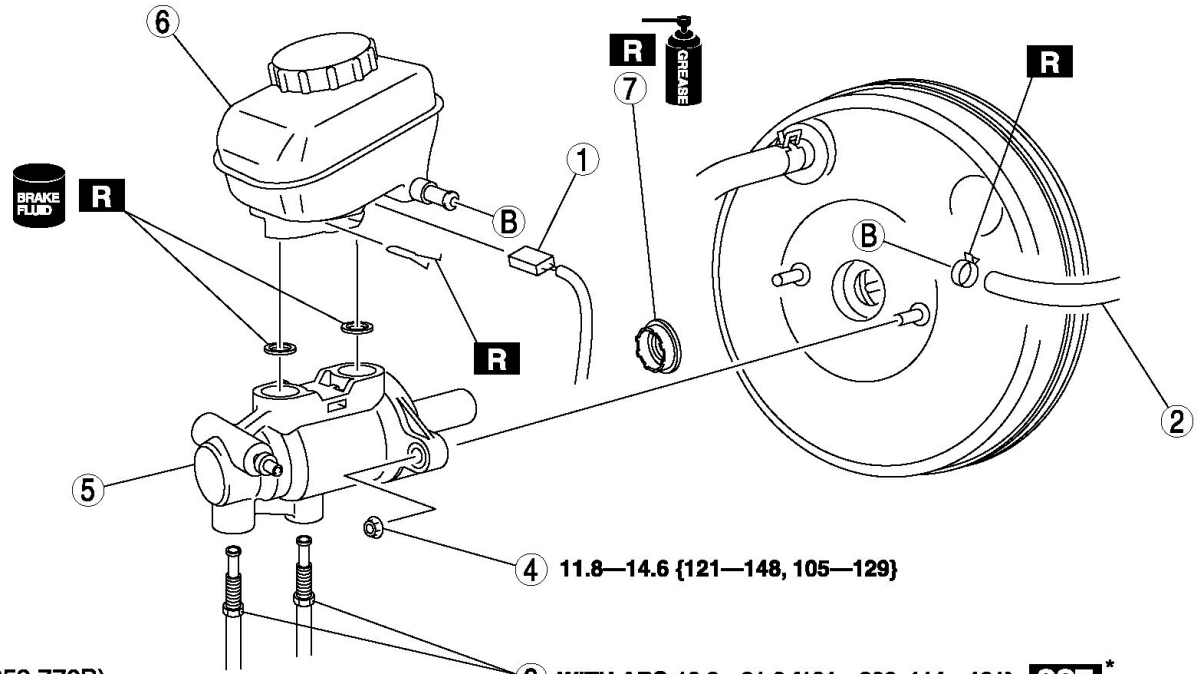

**SST**\* SST(49 0259 770B)  
(FLARE NUT ACROSS FLAT 10 mm {0.39 in})

**A**\* COMMERCIALY AVAILABLE FLARE NUT WRENCH  
(FLARE NUT ACROSS FLAT 12 mm {0.47 in})

**3** WITH ABS:12.8—21.6 {131—220, 114—191}  
WITH DSC:12.8—17.3 {131—176, 114—153}

**SST**\*  
**A**\*

N·m {kgf·cm, In·l}

1	Brake fluid level sensor connector
2	Hose (MT)
3	Brake pipe
4	Nut
5	Master cylinder
6	Reserve tank
7	Front seal

### Master Cylinder Installation Note

#### CAUTION:

- If the master cylinder is installed at an angle, the master cylinder piston may push against the push rod retainer of the power brake unit causing poor air bleeding, brake drag, or other malfunctions. Be sure to install the master cylinder at a perpendicular angle to the power brake unit.

1. Install the **SST** to the power brake unit and tighten to the specified torque.

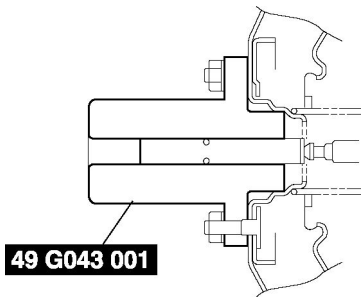

### Tightening torque

- 11.8—14.6 N·m {121—148 kgf·cm, 105—129 in·lbf}
2. Apply a vacuum of **66.7 kPa {500 mmHg, 19.7 inHg}** to the power brake unit using a vacuum gauge.

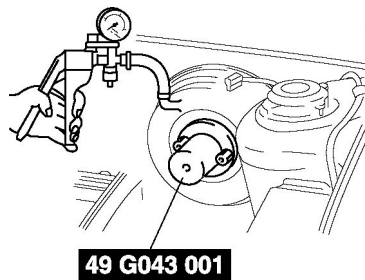

### NOTE:

- Use any commercially available vacuum gauge.
3. Using calipers, measure dimension L as shown in the figure.

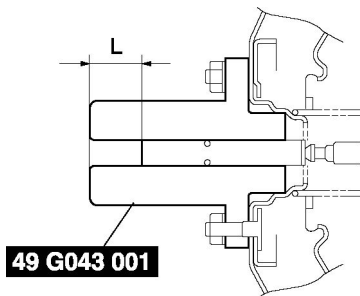

### Standard L dimension

- 22.9—23.2 mm {0.902—0.913 in}
4. If dimension L is not within the standard, remove the SST (49 G043 001) and, while stopping the push rod rotation with the SST (49 E043 003A), adjust the push rod length with the SST (49 B043 004).

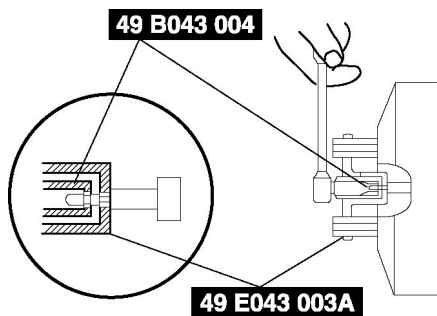

5. Switch the SSTs and remeasure dimension L.
6. Install the front seal to the power brake unit.
7. Install the master cylinder to the power brake unit.

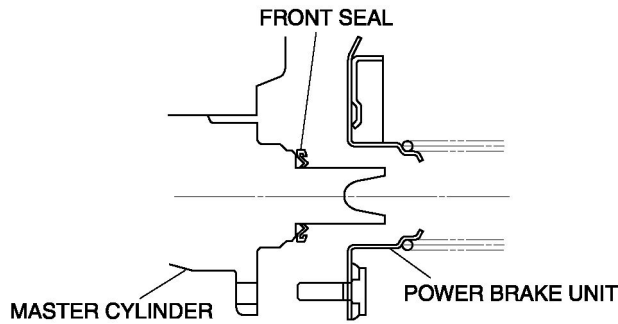

### CAUTION:

- After installing the master cylinder, if air still exists in the brake lines even after performing brake bleeding, brake drag occurs, or other malfunctions are present, it is possible that the master cylinder piston is jammed against the push rod retainer of the power brake unit. If air cannot be bled completely, brake drag exists, or other malfunctions occur, remove the master cylinder and reinstall it properly.
- Do not install the master cylinder with the front seal lip protruding. Doing so will create a vacuum leak and loss of braking force.

## BRAKE FLUID LEVEL SENSOR INSPECTION

1. Disconnect the brake fluid level sensor connector from the master cylinder.
2. Inspect for continuity according to fluid level between the brake fluid level sensor terminals.
  - If not as indicated in the table, replace the reserve tank.

○—○: Continuity

Condition	Terminal	
	A	B
Above MIN		
Below MIN	○—○	○—○

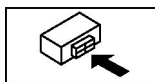

# POWER BRAKE UNIT

## POWER BRAKE UNIT INSPECTION

### NOTE:

- The following inspection methods are simple inspection methods to judge the function of the power brake unit.
- If there is any malfunction in the power brake unit, replace the power brake unit as a single unit.

### Without Using SST

#### Operation inspection

1. With the engine stopped, depress the pedal several times.
2. With the pedal depressed, start the engine.
3. If the pedal moves down slightly immediately after starting the engine, the unit is normal.

#### Vacuum function inspection

1. Start the engine.
2. After driving the vehicle for **1—2 min** , stop the engine.
3. Depress the pedal with normal force.
4. If the first pedal stroke is long and becomes shorter with subsequent strokes, the unit is normal.
  - If a problem is found, inspect for damage to or improper installation of the check valve and vacuum hose. After repairing, inspect again.

#### Vacuum loss function inspection

1. Start the engine.
2. Depress the pedal with normal force.
3. With the pedal depressed, stop the engine.
4. Maintain the pedal depressed for **approx. 30 s** .
5. If the pedal height does not change during this time, the unit is normal.

### Using SST

#### Pre-inspection preparation

1. Install the SST (49 D043 002) in the orientation shown in the figure. (with DSC)

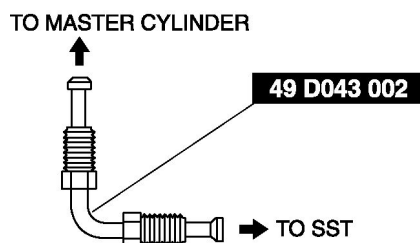

### NOTE:

- Install the SST (49 D043 002) to the master cylinder using a commercially available flare nut wrench.
  - Flare nut across flat: **12 mm {0.47 in}**
- 2. Connect the SSTs , a vacuum gauge and a pedal force gauge to the master cylinder and bleed the air from the SSTs and the brake line. (Bleed the air from the SSTs through air bleeding valve A.)

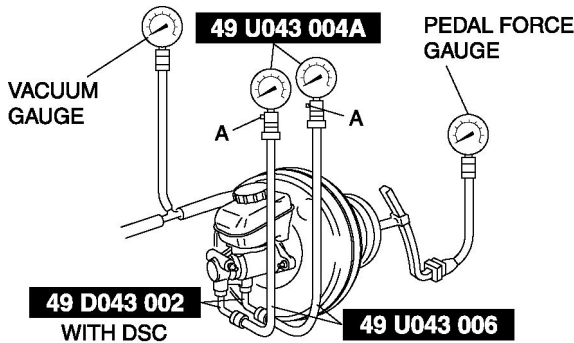

#### Checking for vacuum loss (loaded condition)

1. Start the engine.
2. Depress the brake pedal with a force of **200 N {20.4 kgf, 44.9 lbf}** .
3. With the brake pedal depressed, turn off the engine when the vacuum gauge reaches **68 kPa {510 mmHg, 20.1 inHg}** .
4. Within **15 s** right after stopping the engine, measure the lowest amount of vacuum.
5. If the lowest amount is **3.3 kPa {25 mmHg, 1.0 inHg}** or less, the system is normal.

#### Lack of hydraulic pressure inspection

1. With the engine stopped and the vacuum amount at **0 kPa {0 mmHg, 0 inHg}** if the pedal force and fluid pressure correlation is within the specification, the system is normal. Standard fluid pressure

Pedal force	Fluid pressure
(N {kgf, lbf})	(kPa {kgf/cm <sup>2</sup> , psi})
200 {20.4, 44.9}	606 {6.18, 87.9} or more

#### Hydraulic pressure inspection

1. Start the engine and when the vacuum amount reaches **66.7 kPa {500 mmHg, 19.7 inHg}** , depress the brake pedal.
2. At this time, apply the indicated pedal force and if the fluid pressure is within the specification, the unit is normal. Standard fluid pressure

Pedal force	Fluid pressure
(N {kgf, lbf})	(kPa {kgf/cm <sup>2</sup> , psi})
200 {20.4, 44.9}	7,310 {74.54, 1,060} or more



# POWER BRAKE UNIT REMOVAL/INSTALLATION

1. Remove the master cylinder.
2. Remove in the order indicated in the table.
3. Install in the reverse order of removal.
4. After installation, perform brake pedal inspection.

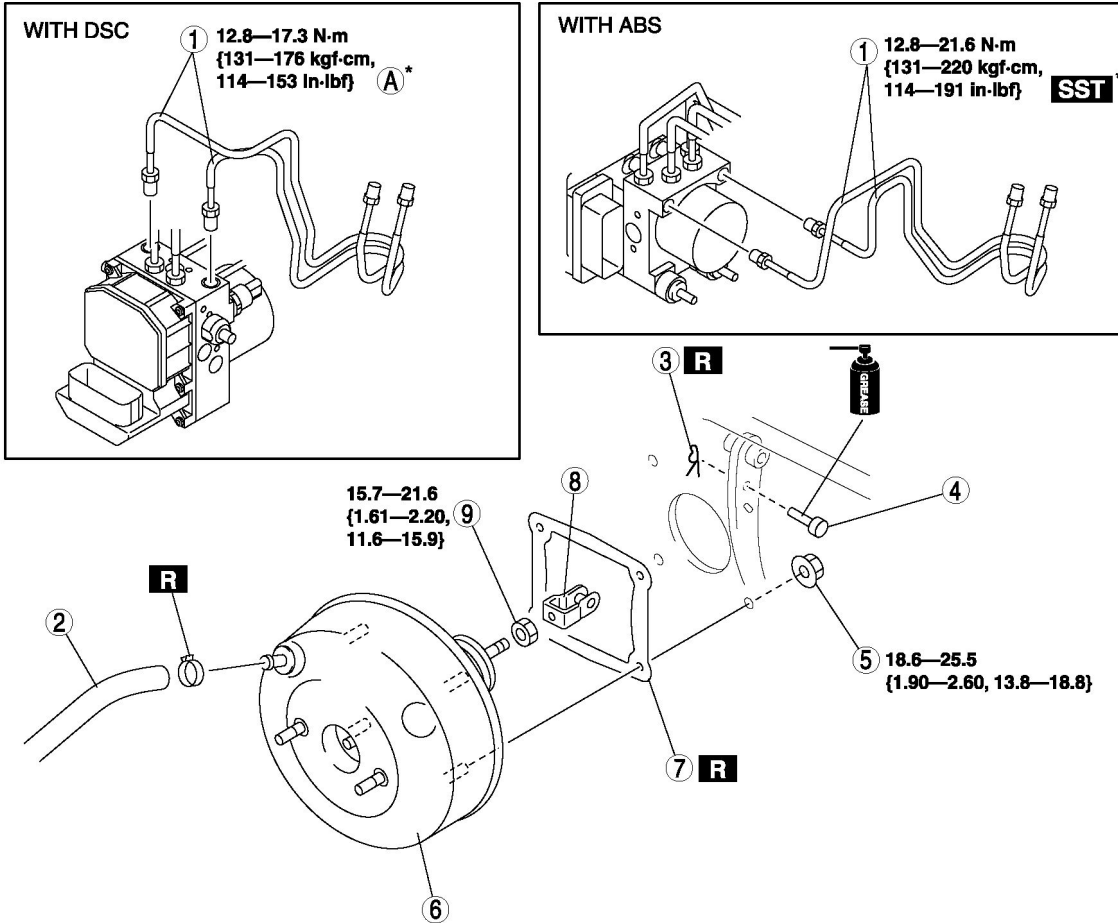

**SST\*** SST(49 0259 770B)  
 (FLARE NUT ACROSS FLAT 10 mm {0.39 in})

**A\*** COMMERCIALY AVAILABLE FLARE NUT WRENCH  
 (FLARE NUT ACROSS FLAT 12 mm {0.47 in})

N·m {kgf·m, ft·lbf}

1	Brake pipe
2	Vacuum hose
3	Snap pin
4	Clevis pin
5	Nut
6	Power brake unit
7	Gasket
8	Fork
9	Locknut

# FRONT BRAKE (DISC)

## FRONT BRAKE (DISC) INSPECTION

### Brake Judder Repair Hints

#### Description

1. Brake judder concern has the following 3 characteristics:

#### Steering wheel vibration

1. Steering wheel vibrates in the rotation direction. This characteristic is most noticeable when applying brakes at a vehicle speed of **100—140 km/h {62.1—86.8 mph}** .

#### Floor vibration

1. When applying the brakes, the vehicle body shakes back and forth. The seriousness of the shaking is not influenced by vehicle speed.

#### Brake pedal vibration

1. When applying brakes, a pulsating force tries to push the brake pad back. The pulsation is transmitted to the brake pedal.
2. The following are the main possible causes of brake judder:

#### Due to an excessive runout (side-to-side wobble) of the disc plate, the thickness of the disc plate is uneven.

1. If the runout is **more than 0.05 mm {0.002 in}** at the position **10 mm {0.39 in}** from the disc plate edge, uneven wear occurs on the disc plate because the pad contacts the plate unevenly.
2. If the runout is **less than 0.05 mm {0.002 in}** , uneven wear does not occur.

#### The disc plate is deformed by heat.

1. Repeated panic braking may raise the temperature in some portions of disc plate by **approximately 1,000 °C {1,832 °F}** . This results in a deformed disc plate.

#### Due to corrosion, the thickness and friction coefficient of disc plate change.

1. If a vehicle is parked in damp conditions for a long time, corrosion occurs on the friction surface of disc plate.
2. The thickness of corrosion is uneven and sometimes appears like a wave pattern, which changes the friction coefficient and causes a reaction force.

#### Inspection and repair procedure

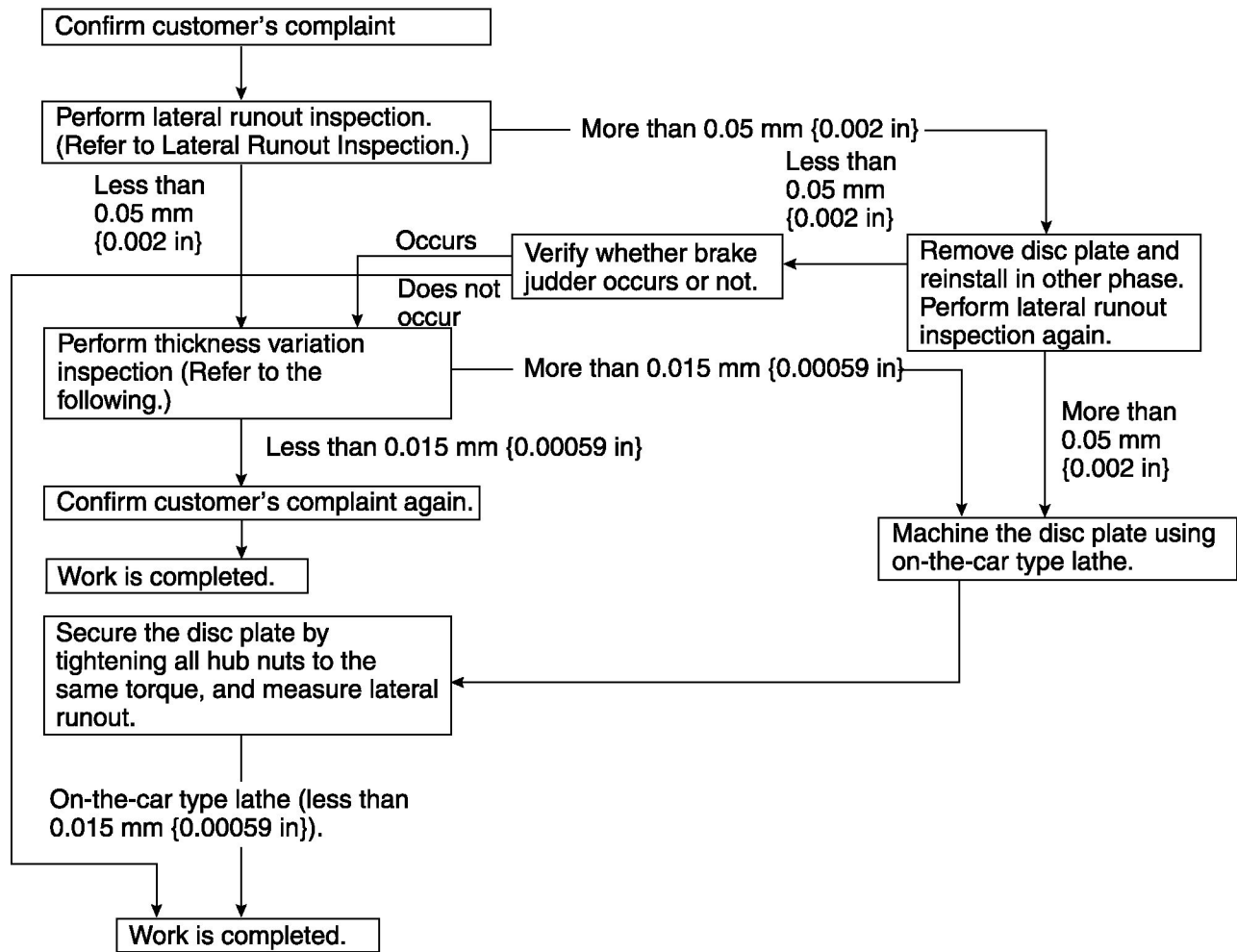

### Lateral runout inspection

- To secure the disc plate and the hub, insert the washer (thickness **10 mm {0.39 in}** , inner diameter **more than 12 mm {0.47 in}** ) between each hub bolt and the hub nut, then tighten all the hub nuts.

#### NOTE:

- The component parts of the SST (49 B017 001 or 49 G019 003) can be used as a suitable washer.
- After tightening all the hub nuts to the same torque, put the dial gauge on the friction surface of disc plate 10 mm {0.12—0.28 in} from the disc plate edge.

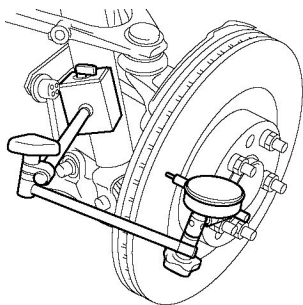

- Rotate the disc plate one time and measure the runout.

### Runout limit

- 0.05 mm {0.002 in}

### Thickness variation inspection

1. Clean the disc plate-to-pad friction surface using a brake cleaner.
2. Measure the points indicated in the illustration using a caliper (micrometer).

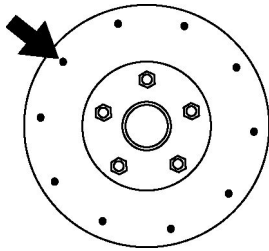

3. Subtract the minimum value from the maximum, and if the result is not within specification, machine the disc plate using a lathe.

### Thickness variation limit

- 0.015 mm {0.00059 in}

### WARNING:

- Do not exceed minimum disc plate thickness.

### Disc Plate Thickness Inspection

### CAUTION:

- Excessive runout may result if the disc plate is removed from the vehicle then machined. Machine the disc plate while installed on the vehicle.
1. Measure the thickness of the disc plate.
    - If the thickness is not within the specification, replace the disc plate.

### Minimum

- 22 mm {0.87 in}

### Minimum thickness after machining using a brake lathe on-vehicle

- 22.8 mm {0.90 in}

### Disc Pad Thickness Inspection

1. Jack up the front of the vehicle and support it with safety stands.
2. Remove the wheel and tires.
3. Verify the remaining thickness of the pads.

### Minimum thickness

o 2.0 mm {0.079 in} min.

4. Replace the pads as a set (right and left wheels) if either one is at or less than the minimum thickness.

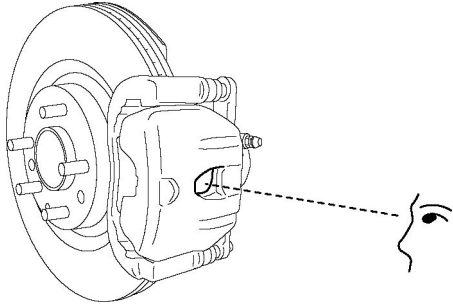

## FRONT BRAKE (DISC) REMOVAL/INSTALLATION

1. Remove in the order indicated in the table.
2. Install in the reverse order of removal.
3. After installation, depress the brake pedal a few times, then verify that the brakes do not drag.

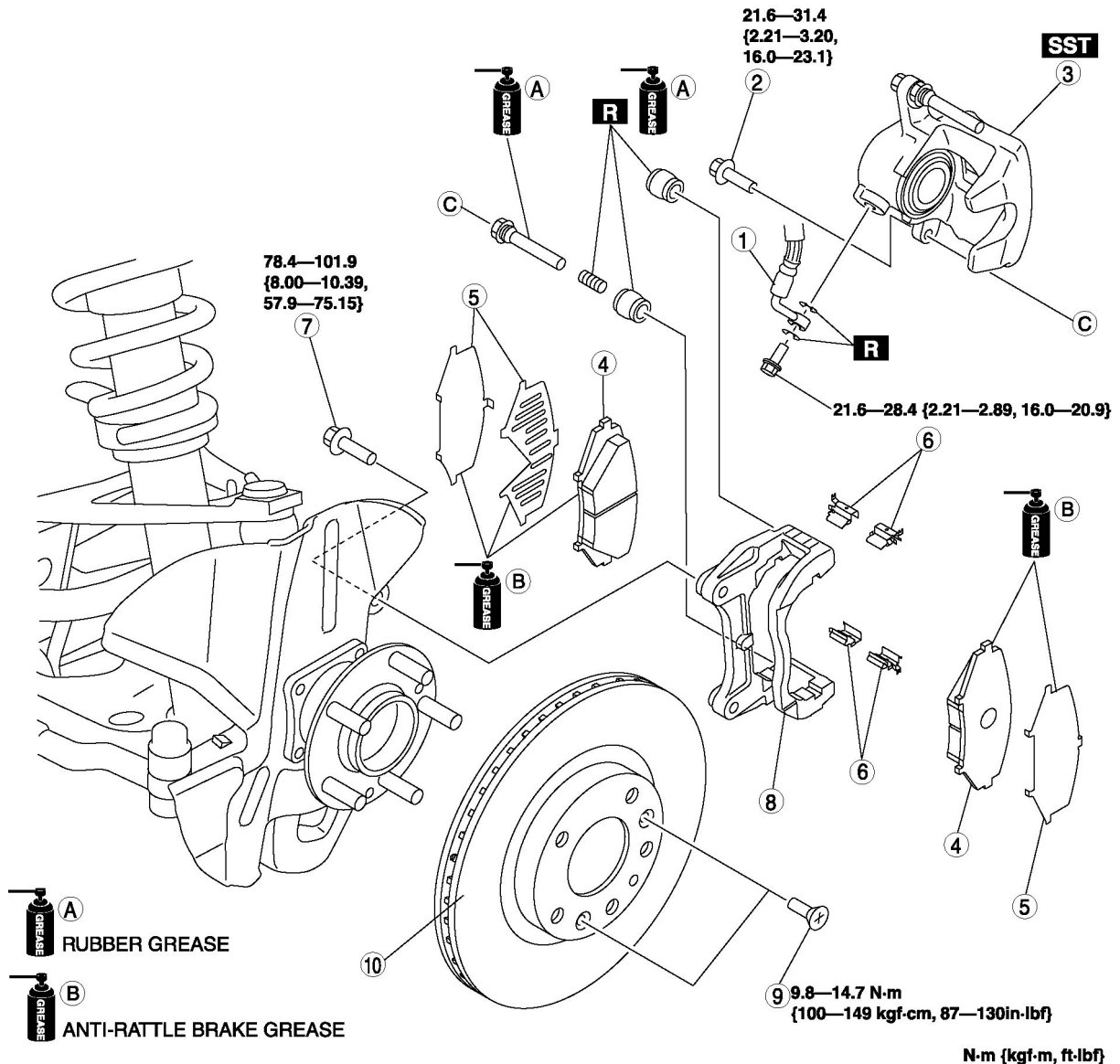

1	Brake hose
2	Bolt
3	Caliper
4	Disc pad
5	Shim
6	Guide plate
7	Bolt
8	Mounting support
9	Screw
10	Disc plate

### Caliper Installation Note

1. Clean the exposed area of the piston.
2. Install the piston using the SST .

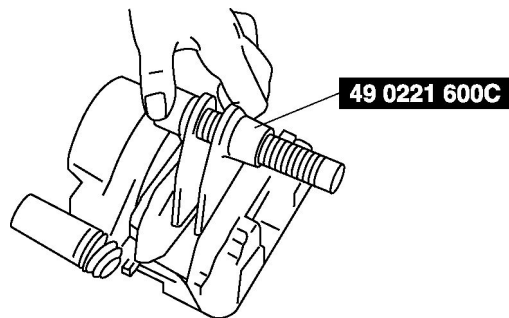

3. Install the caliper.

# DISC PAD (FRONT)

## DISC PAD (FRONT) REPLACEMENT

1. Remove in the order indicated in the table.
2. Install in the reverse order of removal.
3. After installation, depress the brake pedal a few times, then verify that the brakes do not drag.

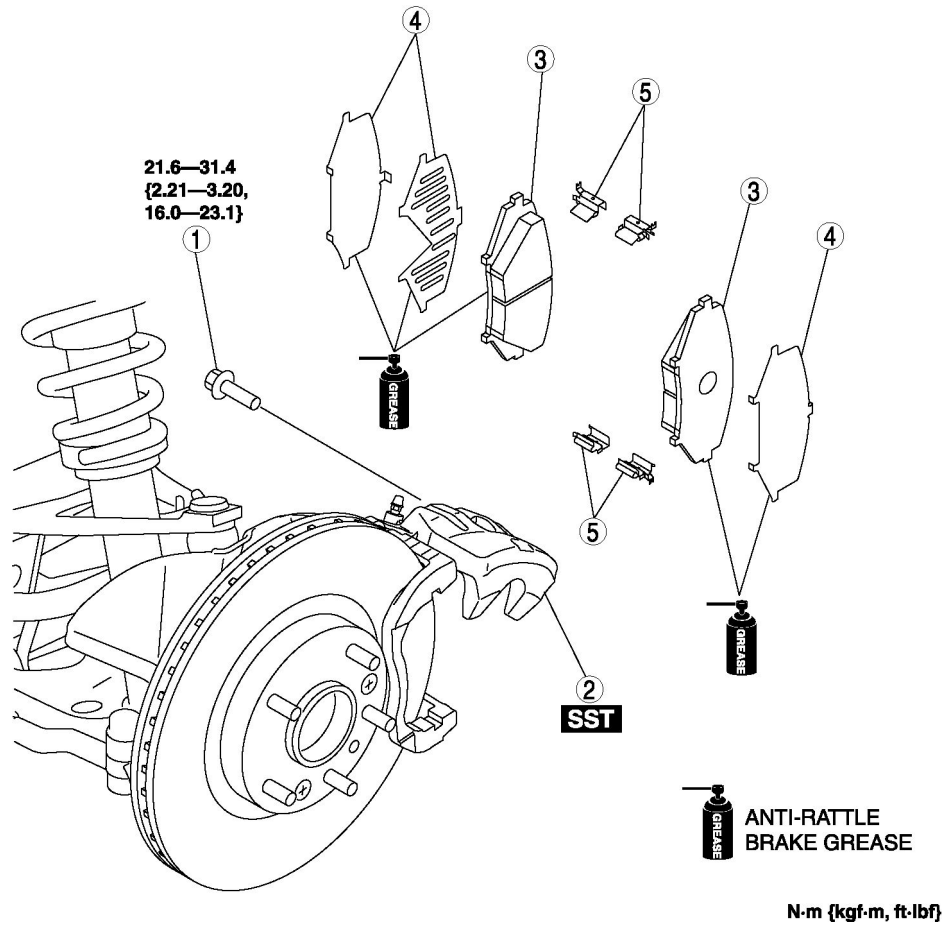

1	Bolt
2	Caliper
3	Disc pad
4	Shim
5	Guide plate

## CALIPER (FRONT) DISASSEMBLY/ASSEMBLY

1. Disassemble in the order indicated in the table.

1	Bleeder cap
2	Bleeder screw
3	Bolt
4	Sleeve
5	Piston
6	Dust seal
7	Piston seal
8	Caliper body

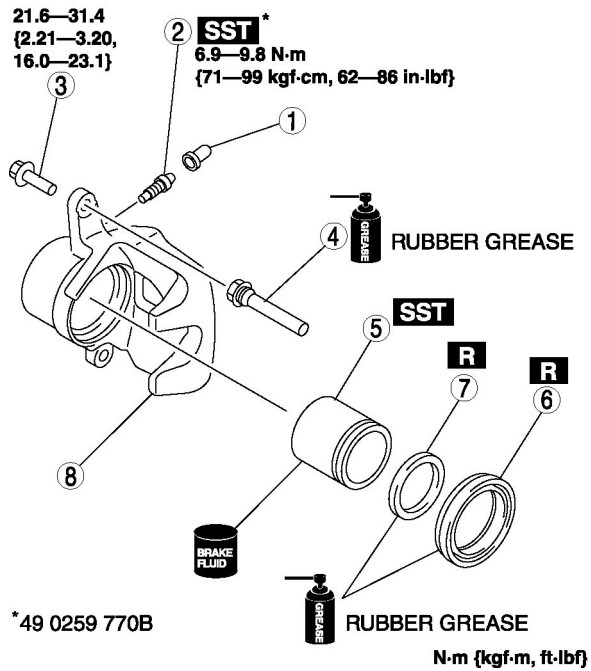

2. Assemble in the reverse order of disassembly.

### Piston Disassembly Note

#### CAUTION:

- The piston could be damaged if blown out with great force. Blow the compressed air slowly to prevent the piston from suddenly popping out.
- Insert a piece of wood in the caliper as shown in the figure, and then blow compressed air through the bleeder screw hole to remove the piston from the caliper body.

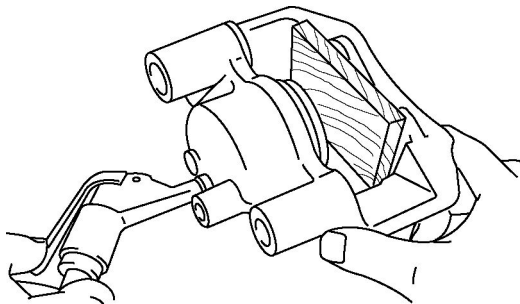



# REAR BRAKE (DISC)

## REAR BRAKE (DISC) INSPECTION

### Brake Judder Repair Hints

#### Description

1. Brake judder concern has the following 3 characteristics:

#### Steering wheel vibration

1. Steering wheel vibrates in the rotation direction. This characteristic is most noticeable when applying brakes at a vehicle speed of **100—140 km/h {62.1—86.8 mph}** .

#### Floor vibration

1. When applying the brakes, the vehicle body shakes back and forth. The seriousness of the shaking is not influenced by vehicle speed.

#### Brake pedal vibration

1. When applying brakes, a pulsating force tries to push the brake pad back. The pulsation is transmitted to the brake pedal.
2. The following are the main possible causes of brake judder:

#### Due to an excessive runout (side-to-side wobble) of the disc plate, the thickness of the disc plate is uneven.

1. If the runout is **more than 0.05 mm {0.002 in}** at the position **10 mm {0.39 in}** from the disc plate edge, uneven wear occurs on the disc plate because the pad contacts the plate unevenly.
2. If the runout is **less than 0.05 mm {0.002 in}** , uneven wear does not occur.

#### The disc plate is deformed by heat.

1. Repeated panic braking may raise the temperature in some portions of disc plate by **approximately 1,000 °C {1,832 °F}** . This results in a deformed disc plate.

#### Due to corrosion, the thickness and friction coefficient of disc plate change.

1. If a vehicle is parked in damp conditions for a long time, corrosion occurs on the friction surface of disc plate.
2. The thickness of corrosion is uneven and sometimes appears like a wave pattern, which changes the friction coefficient and causes a reaction force.

#### Inspection and repair procedure

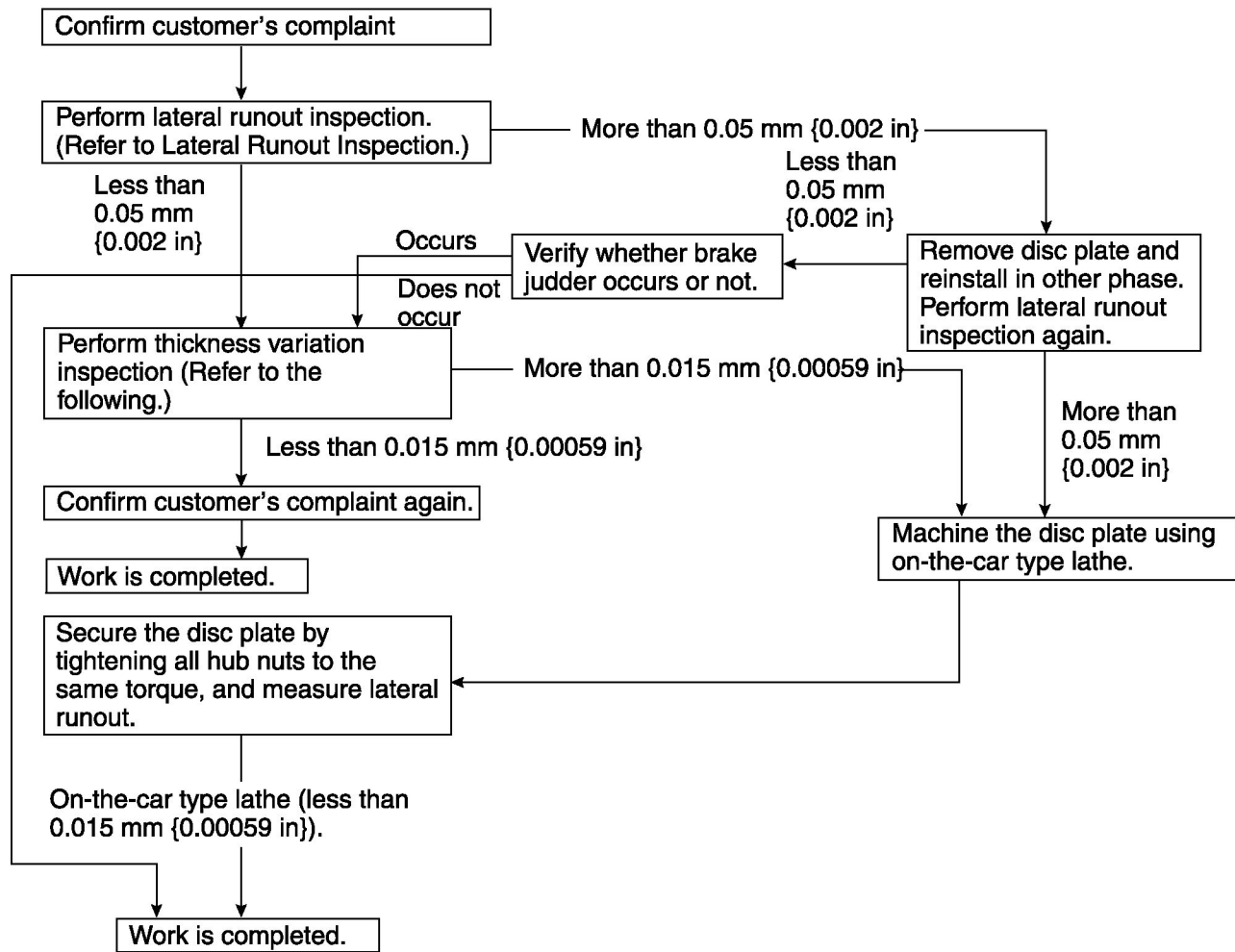

### Lateral runout inspection

- To secure the disc plate and the hub, insert the washer (thickness **10 mm {0.39 in}** , inner diameter **more than 12 mm {0.47 in}** ) between each hub bolt and the hub nut, then tighten all the hub nuts.

#### NOTE:

- The component parts of the SST (49 B017 001 or 49 G019 003) can be used as a suitable washer.
- After tightening all the hub nuts to the same torque, put the dial gauge on the friction surface of disc plate 10 mm {0.39 in} from the disc plate edge.

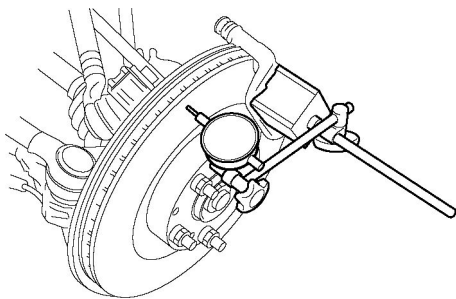

- Rotate the disc plate one time and measure the runout.

### Runout limit

- 0.05 mm {0.002 in}

### Thickness variation inspection

1. Clean the disc plate-to-pad friction surface using a brake cleaner.
2. Measure the points indicated in the illustration using a caliper (micrometer).

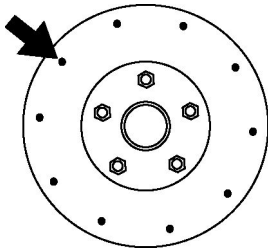

3. Subtract the minimum value from the maximum, and if the result is not within specification, machine the disc plate using a lathe.

### Thickness variation limit

- 0.015 mm {0.00059 in}

### WARNING:

- Do not exceed minimum disc plate thickness.

### Disc Plate Thickness Inspection

### CAUTION:

- Excessive runout may result if the disc plate is removed from the vehicle then machined. Machine the disc plate while installed on the vehicle.
1. Measure the thickness of the disc plate.
    - If the thickness is not within the specification, replace the disc plate.

### Minimum

- 16 mm {0.63 in}

### Minimum thickness after machining using a brake lathe on-vehicle

- 16.8 mm {0.66 in}

### Disc Pad Thickness Inspection

1. Jack up the front of the vehicle and support it with safety stands.
2. Remove the wheel and tires.
3. Verify the remaining thickness of the pads.

### Minimum thickness

- 2.0 mm {0.079 in} min.
4. Replace the pads as a set (right and left wheels) if either one is at or less than the minimum thickness.

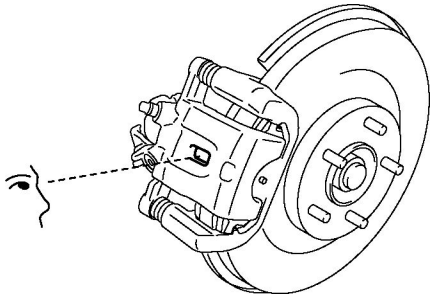

## REAR BRAKE (DISC) REMOVAL/INSTALLATION

1. Remove in the order indicated in the table.
2. Install in the reverse order of removal.
3. After installation, depress the brake pedal a few times, and inspect the following.
  - The disc pad projection is securely installed to the piston groove
  - Parking brake lever stroke
  - Brake drag

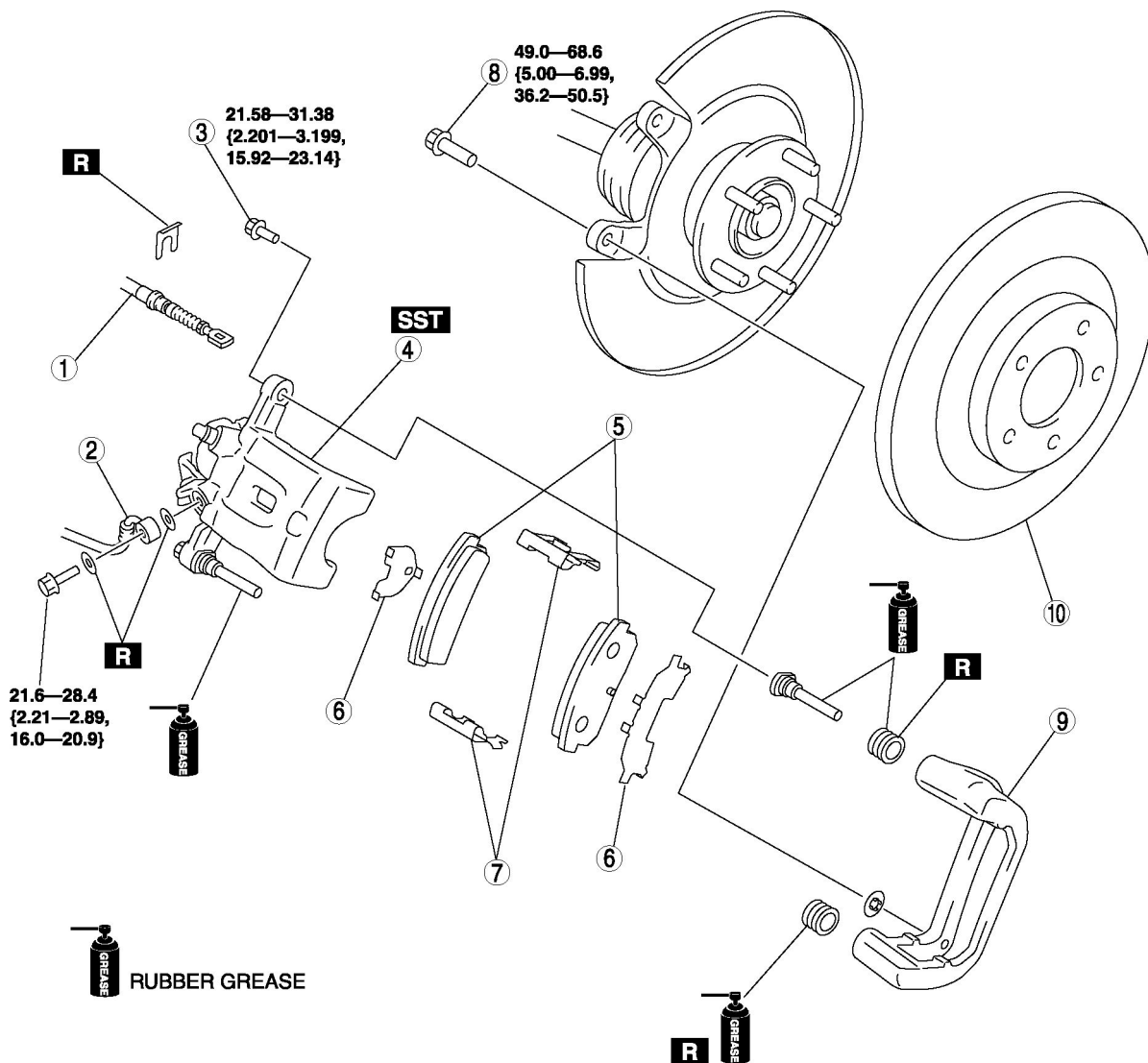

N·m {kgf·m, ft·lbf}

1	Parking brake cable
2	Brake hose
3	Bolt
4	Caliper
5	Disc pad
6	Shim
7	Guide plate
8	Bolt
9	Mounting support
10	Disc plate

### Disc Plate Removal Note

1. Mark the wheel hub and disc plate.

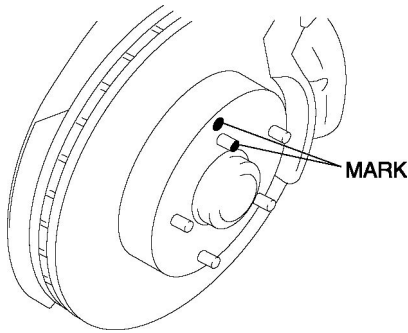

2. Remove the disc plate.

### Disc Plate Installation Note

1. Remove any rust or foreign material from the wheel hub and disc plate.
2. Align the marks made before removal and install the disc plate to the wheel hub.

### Caliper Installation Note

1. Clean the exposed area of the piston.
2. Rotate the piston clockwise slowly using the SST and push the piston completely until the piston grooves are in the position shown in the figure.

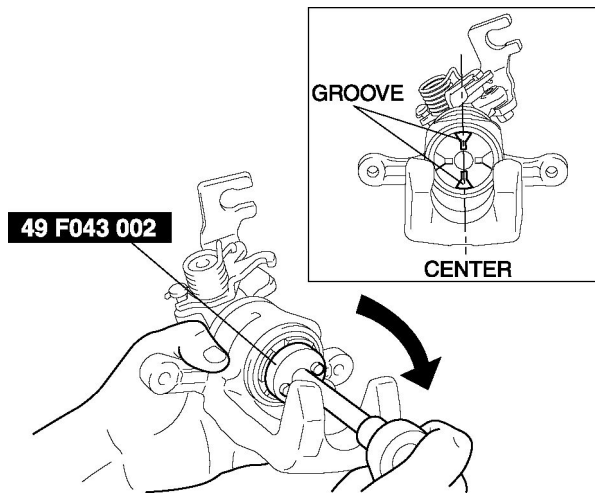

3. Install the caliper.

### Parking Brake Cable Installation Note

1. After installing the parking brake cable, verify that the operating lever returns to the stopper nut with the parking brake lever released.

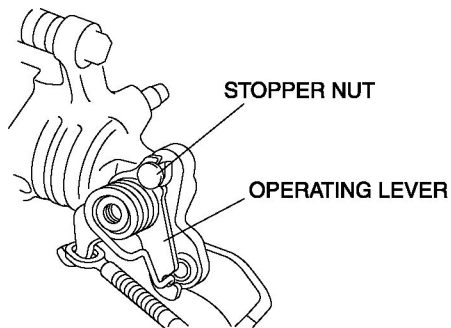

# DISC PAD (REAR)

## DISC PAD (REAR) REPLACEMENT

1. Remove in the order indicated in the table.
2. Install in the reverse order of removal.
3. After installation, depress the brake pedal a few times, and inspect the following.
  - The disc pad projection is securely installed to the piston groove
  - Parking brake lever stroke
  - Brake drag

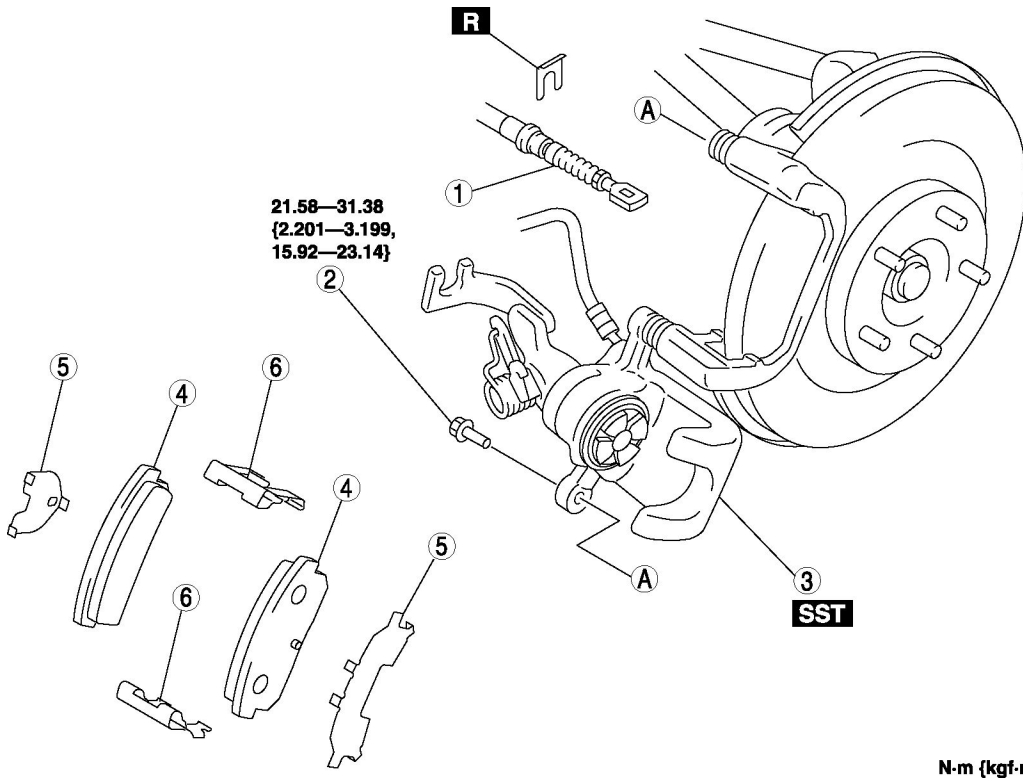

N-m {kgf-m, ft-lbf}

1	Parking brake cable
2	Bolt
3	Caliper
4	Disc pad
5	Shim
6	Guide plate

### Caliper Installation Note

1. Clean the exposed area of the piston.
2. Rotate the piston clockwise slowly using the SST and push in the piston completely until the piston grooves are in the position shown in the figure.

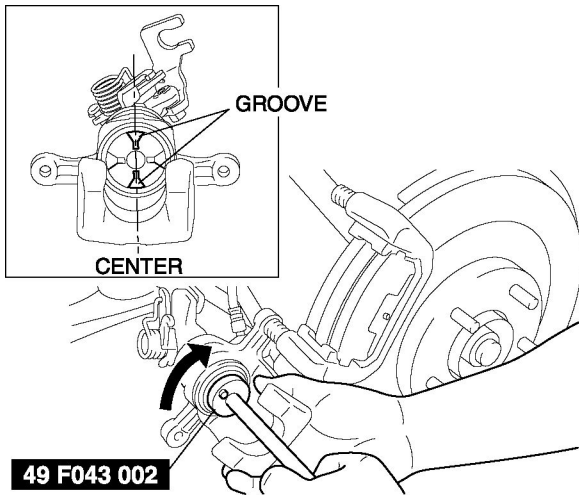

3. Install the caliper.

## CALIPER (REAR)

### CALIPER (REAR) DISASSEMBLY/ASSEMBLY

1. Disassemble in the order indicated in the table.

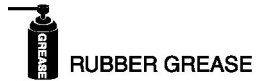
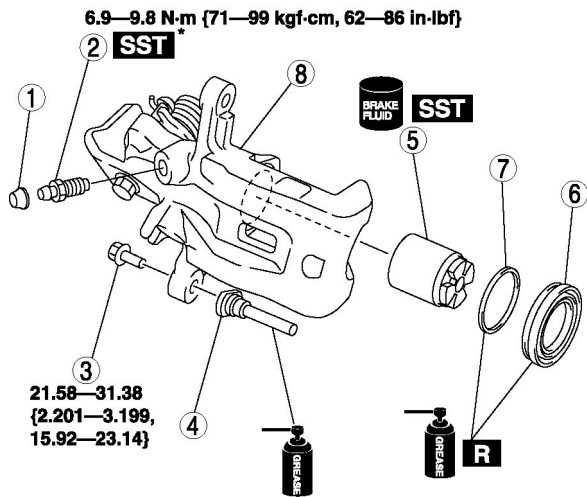

\* 49 0259 770B

N·m {kgf·m, ft·lbf}

1	Bleeder cap
2	Bleeder screw
3	Bolt
4	Sleeve
5	Piston
6	Dust seal
7	Piston seal



## 8 Caliper body

2. Assemble in the reverse order of disassembly.

### Piston Disassembly Note

1. Rotate the piston counter-clockwise using the SST , remove the piston from the caliper body.

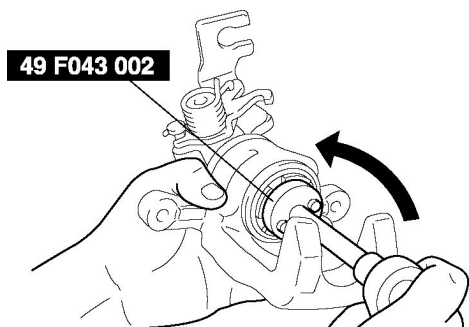

### Dust Seal, Piston Assembly Note

1. Assemble the dust seal to the piston.
2. Assemble the lip of the dust seal to the groove of the caliper body with the dust seal is assembled to the piston as shown in the figure.

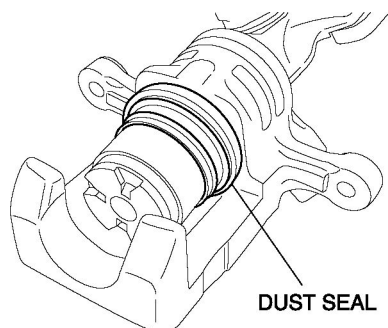

3. Rotate the piston clockwise using the SST slowly and push the piston inwards completely.

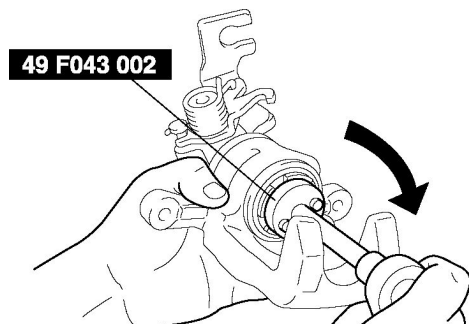

4. Verify that the dust seal is installed into the groove of the piston securely.

# ANTILOCK BRAKE SYSTEM

## ABS LOCATION INDEX

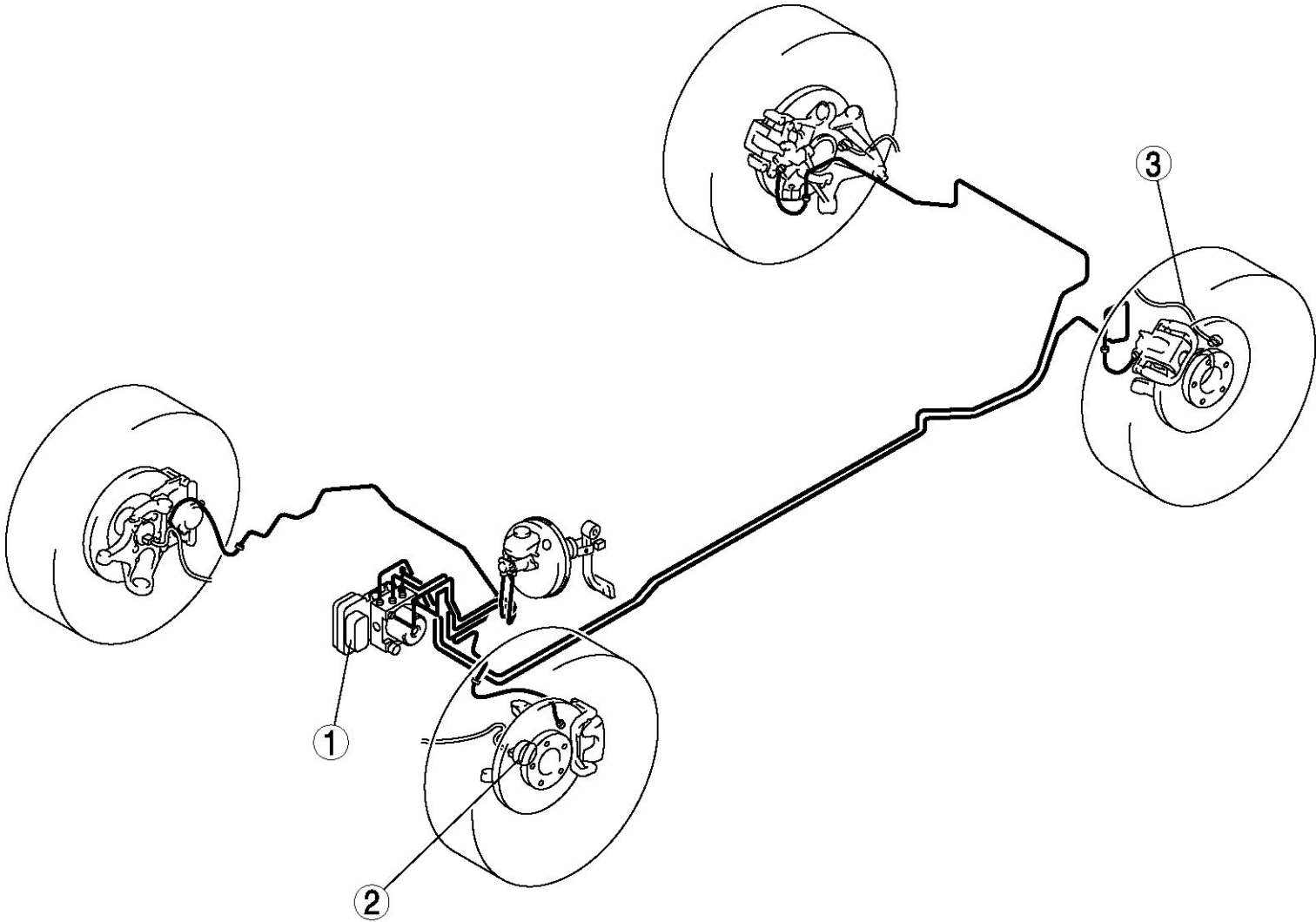

1	ABS HU/CM
2	Front ABS wheel-speed sensor
3	Rear ABS wheel-speed sensor

# ABS SYSTEM DIAGRAM

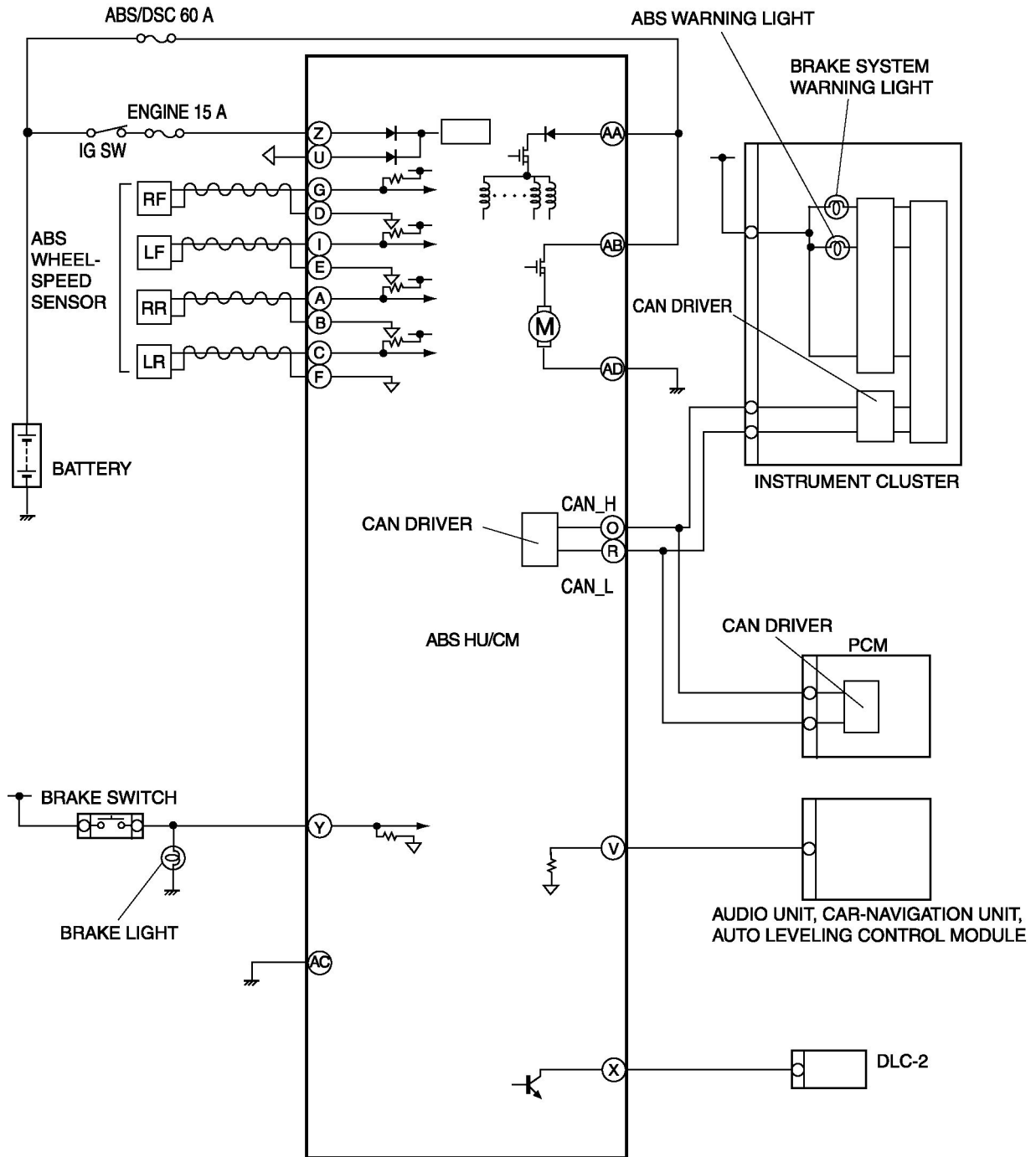

# ABS SYSTEM INSPECTION

## ABS HYDRAULIC UNIT ON-VEHICLE INSPECTION

### Preparation

1. Verify that battery is fully charged.
2. Turn the ignition switch to the ON position and verify that the ABS warning light goes out after **approx. 3 s**.
3. Turn the ignition switch off.
4. Jack up the vehicle and support it evenly on safety stands.
5. Shift to neutral.
6. Release the parking brake.
7. Verify that all four wheels rotate.
8. Rotate the wheels by hand, and verify there is no brake drag.
  - If there is any brake drag, perform regular brake inspection.
  - If there is no brake drag, perform ABS HU/CM operation inspection.

### Operation inspection

1. Perform "Preparation".
2. Connect the WDS or equivalent to the DLC-2.

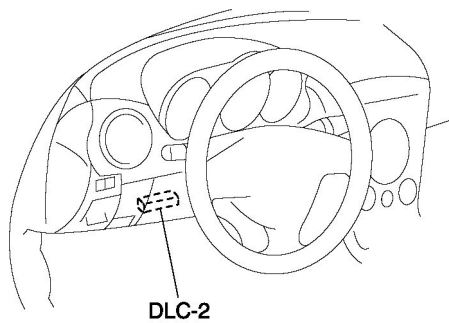

3. Set up an active command mode inspection according to the combination of commands below.

Operation condition	Command name				Command transmission type
	PMP_MOTOR	RF_OUTLET	RF_INLET	ABS_POWER	
Brake pressure retention	OFF	OFF	ON	ON	Manual
Brake pressure reduction	ON	ON	ON	ON	

4. The chart above shows an example of a right front wheel inspection.
5. **CAUTION:**
  - To protect the ABS HU/CM, the solenoid valve and the pump motor used during active command mode stay on for only 10 s or less each time they are switched on.

### NOTE:

- When working with two people, one should press on the brake pedal, and the other should attempt to rotate the wheel being inspected.

6. Send the command while depressing the brake pedal and attempting to rotate the wheel being inspected.
7. Performing the inspection above determines the following:
  - The ABS HU/CM brake lines are normal.
  - The ABS HU/CM hydraulic system is not significantly abnormal (including inside ABS HU/CM).
  - The ABS HU/CM internal electrical parts (solenoid, motor and other parts) are normal.
  - The ABS HU/CM output system wiring harnesses (solenoid valve, relay system) are normal.
    - However, the following items cannot be verified.
      - Malfunction of ABS HU/CM input system wiring harnesses and parts
      - Extremely small leaks in the ABS HU/CM internal hydraulic system
      - Malfunction with intermittent occurrence of the above items

Notes:

# ABS HYDRAULIC UNIT/CONTROL MODULE

## ABS HU/CM REMOVAL/INSTALLATION

### CAUTION:

- The internal parts of the ABS HU/CM could be damaged if dropped. Be careful not to drop the ABS HU/CM. Replace the ABS HU/CM if it is subjected to an impact.
- Remove the front suspension tower bar. (See [FRONT SUSPENSION TOWER BAR REMOVAL/INSTALLATION](#).)
  - Remove in the order indicated in the table.
  - Install in the reverse order of removal.

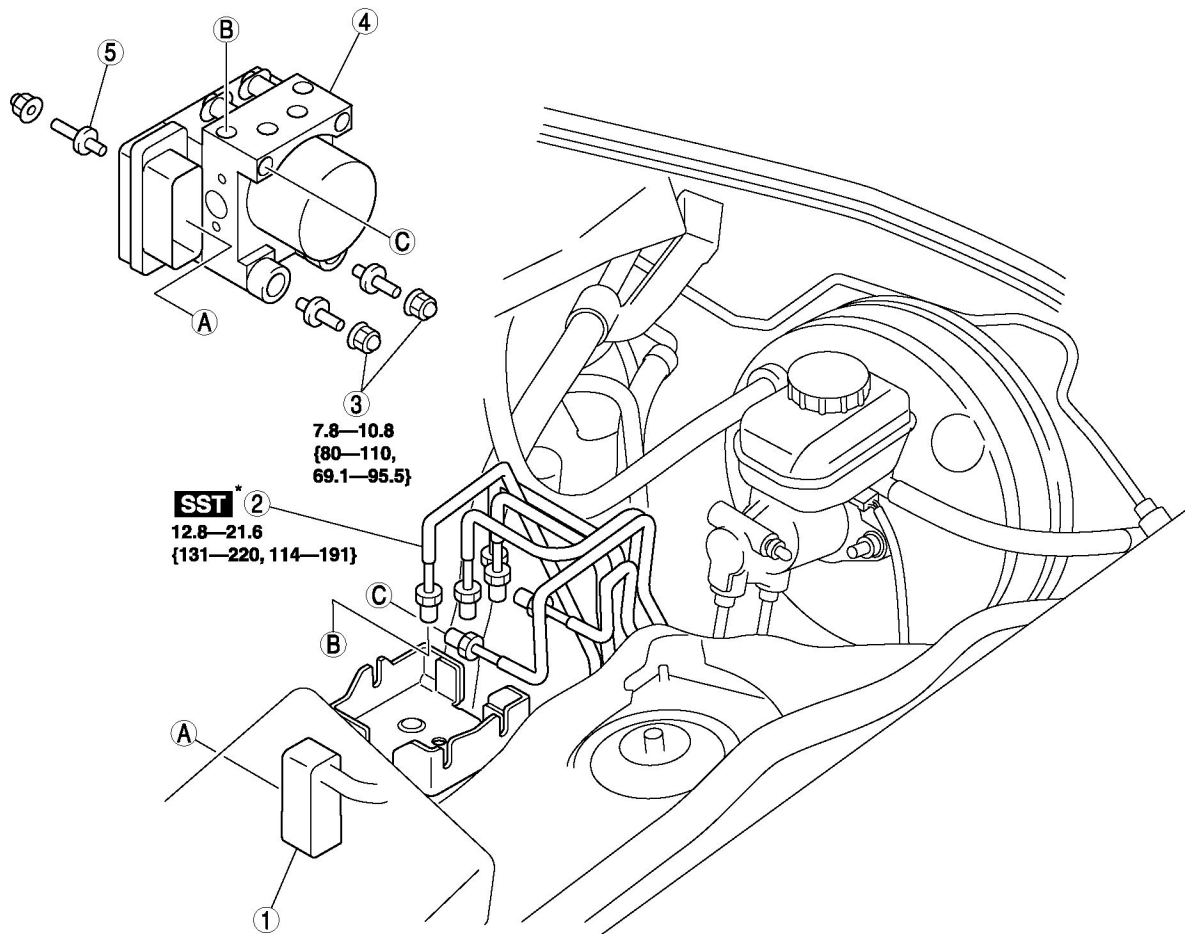

\* 49 0259 770B

N·m (kgf·cm, in·lbf)

1	Connector
2	Brake pipe
3	Nut
4	ABS HU/CM
5	Stud

## Connector Removal Note

1. Pull the lock lever up, and then remove the connector.

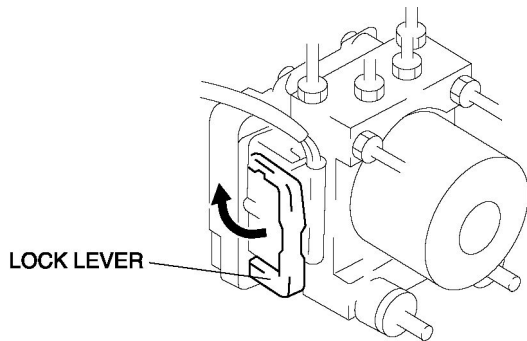

## ABS HU/CM Removal/Installation Note

1. When removing/installing the ABS HU/CM from/to the vehicle, attach a strip of protective tape on the ABS HU/CM connector to prevent brake fluid from entering.

## Connector Installation Note

1. After connecting the connector, verify that the lock lever is completely pushed in.

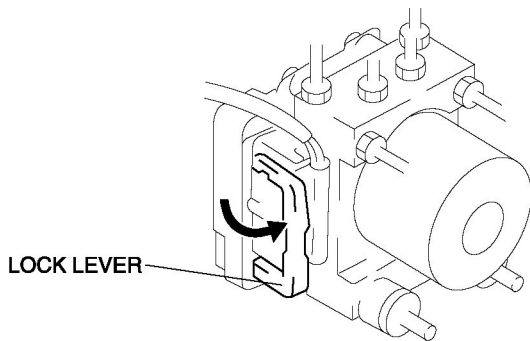

## ABS HU/CM INSPECTION

1. Disconnect the ABS HU/CM connector.
2. Connect the negative battery cable.
3. Attach the tester lead to the ABS HU/CM harness side connector, then inspect voltage, continuity or resistance according to the standard (reference value) on the table.

## Standard (Reference Value)

ABS HU/CM WIRING HARNESS-SIDE CONNECTOR

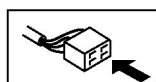
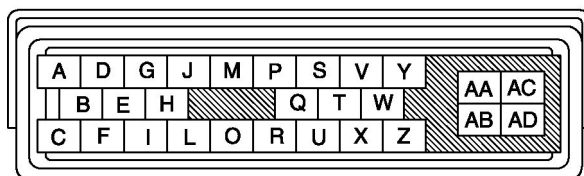

Terminal	Signal name	Connected to	Measured item	Measured terminal (measured condition)	Standard	Inspection item(s)
A	RR wheel-speed sensor (signal)	RR ABS wheel-speed sensor	Continuity	A—RR ABS wheel-speed sensor connector terminal A	Continuity detected	<ul style="list-style-type: none"> <li>Wiring harness (A—RR ABS wheel-speed sensor connector terminal A)</li> </ul>
B	RR wheel-speed sensor (ground)	RR ABS wheel-speed sensor	Continuity	B—RR ABS wheel-speed sensor connector terminal B	Continuity detected	<ul style="list-style-type: none"> <li>Wiring harness (B—RR ABS wheel-speed sensor connector terminal B)</li> </ul>
C	LR wheel-speed sensor (signal)	LR ABS wheel-speed sensor	Continuity	C—LR ABS wheel-speed sensor connector terminal A	Continuity detected	<ul style="list-style-type: none"> <li>Wiring harness (C—LR ABS wheel-speed sensor connector terminal A)</li> </ul>
D	RF wheel-speed sensor (ground)	RF ABS wheel-speed sensor	Continuity	D—RF ABS wheel-speed sensor connector terminal B	Continuity detected	<ul style="list-style-type: none"> <li>Wiring harness (D—RF ABS wheel-speed sensor connector terminal B)</li> </ul>
E	LF wheel-speed sensor (ground)	LF ABS wheel-speed sensor	Continuity	E—LF ABS wheel-speed sensor connector terminal B	Continuity detected	<ul style="list-style-type: none"> <li>Wiring harness (E—LF ABS wheel-speed sensor connector terminal B)</li> </ul>
F	LR wheel-speed sensor (ground)	LR ABS wheel-speed sensor	Continuity	F—LR ABS wheel-speed sensor connector terminal B	Continuity detected	<ul style="list-style-type: none"> <li>Wiring harness (F—LR ABS wheel-speed sensor connector terminal B)</li> </ul>



						terminal B)
G	RF wheel-speed sensor (signal)	RF ABS wheel-speed sensor	Continuity	G—RF ABS wheel-speed sensor connector terminal A	Continuity detected	<ul style="list-style-type: none"> <li>Wiring harness (G—RF ABS wheel-speed sensor connector terminal A)</li> </ul>
H	—	—	—	—	—	—
I	LF wheel-speed sensor (single)	LF ABS wheel-speed sensor	Continuity	I—LF ABS wheel-speed sensor connector terminal A	Continuity detected	<ul style="list-style-type: none"> <li>Wiring harness (I—LF ABS wheel-speed sensor connector terminal A)</li> </ul>
J	—	—	—	—	—	—
K	—	—	—	—	—	—
L	—	—	—	—	—	—
M	—	—	—	—	—	—
N	—	—	—	—	—	—
O	CAN_H	DLC-2 (CAN_H)	Continuity	O—DLC-2 terminal CAN_H	Continuity detected	<ul style="list-style-type: none"> <li>Wiring harness (O—DLC-2 terminal CAN_H)</li> </ul>
P	—	—	—	—	—	—
Q	—	—	—	—	—	—
R	CAN_L	DLC-2 (CAN_L)	Continuity	R—DLC-2 terminal CAN_L	Continuity detected	<ul style="list-style-type: none"> <li>Wiring harness (R—DLC-2 terminal CAN L)</li> </ul>
S	—	—	—	—	—	—
T	—	—	—	—	—	—
U	—	—	—	—	—	—

V	Vehicle speed output	Audio unit	Continuity	V—audio unit	Continuity detected	<ul style="list-style-type: none"> <li>Wiring harness (V—audio unit)</li> </ul>
		Car-navigation unit		V—car-navigation unit		<ul style="list-style-type: none"> <li>Wiring harness (V—car-navigation unit)</li> </ul>
		Auto leveling control module		V—auto leveling control module		<ul style="list-style-type: none"> <li>Wiring harness (V—auto leveling control module)</li> </ul>
W	—	—	—	—	—	—
X	KLN	DLC-2 (KLN)	Continuity	X—DLC-2 terminal KLN	Continuity detected	<ul style="list-style-type: none"> <li>Wiring harness (X—DLC-2 terminal KLN)</li> </ul>
Y	Brake switch	Brake switch	Voltage	Y—AC (Brake pedal depressed with ignition switch at ON)	B+	<ul style="list-style-type: none"> <li>Wiring harness (T—brake switch)</li> <li>Brake switch</li> </ul>
				Y—AC (Brake pedal not depressed with ignition switch at ON)	1 V or less	
Z	Power supply (system)	Ignition switch	Voltage	Ignition switch at ON	B+	<ul style="list-style-type: none"> <li>Wiring harness (Z—ignition switch)</li> </ul>
				Ignition switch is off.	1 V or less	
AA	Power supply	Battery	Voltage	Under any condition	B+	

	(solenoid)					<ul style="list-style-type: none"> <li>Wiring harness (AA—battery)</li> </ul>
AB	Power supply (ABS motor operation)	Battery	Voltage	Under any condition	B+	<ul style="list-style-type: none"> <li>Wiring harness (AB—battery)</li> </ul>
AC	Ground (ABS system)	Ground point	Continuity	AC—ground point	Continuity detected	<ul style="list-style-type: none"> <li>Wiring harness (AC—ground point)</li> </ul>
AD	Ground (ABS motor)	Ground point	Continuity	AD—ground point	Continuity detected	<ul style="list-style-type: none"> <li>Wiring harness (AD—ground point)</li> </ul>

# FRONT ABS WHEEL-SPEED SENSOR

## FRONT ABS WHEEL-SPEED SENSOR REMOVAL/INSTALLATION

### NOTE:

- If there is any malfunction in the front ABS wheel-speed sensor unit, replace the wheel hub component.
1. Remove the mudguard.
  2. Remove in the order indicated in the table.
  3. Install in the reverse order of removal.

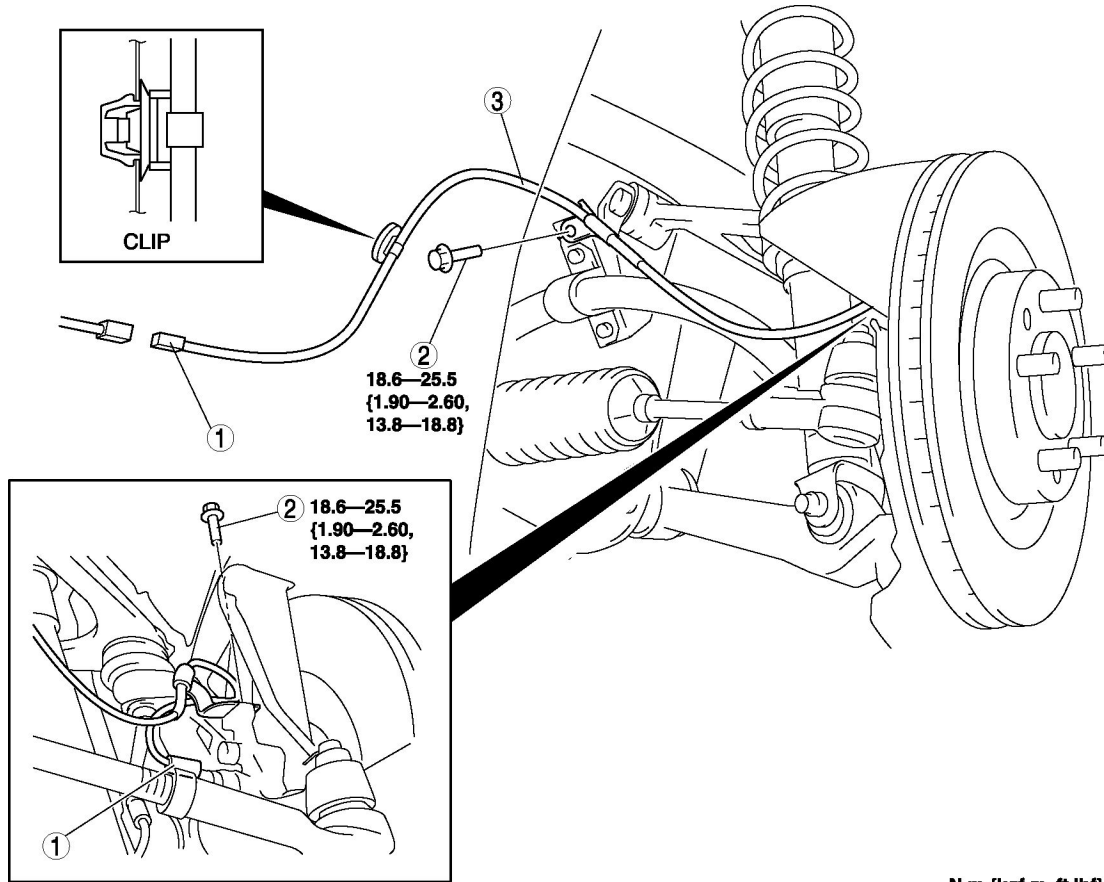

N·m {kgf·m, ft·lbf}

1	Connector
2	Bolt
3	Front ABS wheel-speed sensor wiring harness

## FRONT ABS WHEEL-SPEED SENSOR INSPECTION

### Installation Visual Inspection

1. Inspect the following items:
  - If there is any malfunction, replace the applicable part.
  - b. Excessive play of the ABS wheel-speed sensor
  - c. Deformation of the ABS wheel-speed sensor

## Resistance Inspection

1. Measure the resistance between the ABS wheel-speed sensor terminals.
  - If there is any malfunction, replace the front ABS wheel-speed sensor.

### Resistance

- 0.79—2.2 kilohms

## Voltage Pattern Inspection

1. Lift up the vehicle, and connect an oscilloscope to the ABS wheel-speed sensor connector.
2. While rotating each wheel by hand inspect the voltage pattern.
  - If there is distortion or noise, replace the front ABS wheel-speed sensor.

### Voltage pattern (reference)

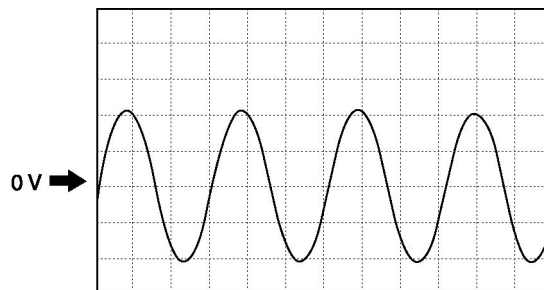

- Oscilloscope setting:  
1 V/DIV (Y), 2 ms/DIV (X), AC range
- Vehicle condition: Driving **30 km/h (18.6 mph)**

### NOTE:

- As the vehicle speed increases, the voltage increases and the wave period shortens.

## Sensor Output Value Inspection

1. Turn the ignition switch off.
2. Connect the WDS or equivalent to the DLC-2.

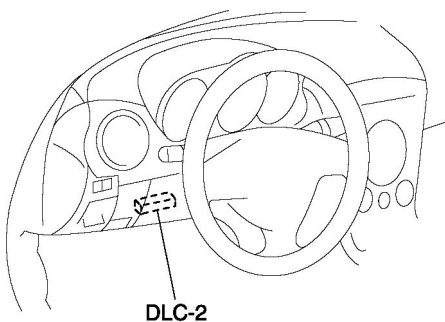

3. Select the following PIDs using the WDS or equivalent:
  - LF\_WSPD

(LF wheel-speed sensor)

- RF\_WSPD

(RF wheel-speed sensor)

4. Start the engine and drive the vehicle.
5. Verify that the display of the WDS or equivalent shows the same value as the speedometer.
  - If there is any malfunction, replace the front ABS wheel-speed sensor.

Notes:

# REAR ABS WHEEL-SPEED SENSOR

## REAR ABS WHEEL-SPEED SENSOR REMOVAL/INSTALLATION

1. Remove the trunk side trim.
2. Remove in the order indicated in the table.

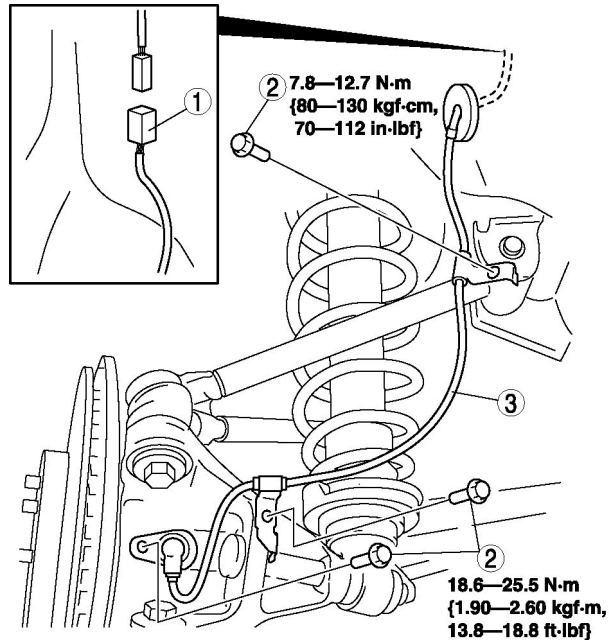

1	Connector
2	Bolt
3	Rear ABS wheel-speed sensor

3. Install in the reverse order of removal.

## REAR ABS WHEEL-SPEED SENSOR INSPECTION

### Installation Visual Inspection

1. Inspect the following items:
  - a. If there is any malfunction, replace the applicable part.
  - b. Excessive looseness or play of the ABS wheel-speed sensor
  - c. Deformation of the ABS wheel-speed sensor
  - d. Deformation or damage of the ABS sensor rotor

### Clearance Inspection

1. Verify the clearance between the ABS sensor rotor and the ABS wheel-speed sensor.
  - a. If there is any malfunction, check for improper installation, and replace if necessary.

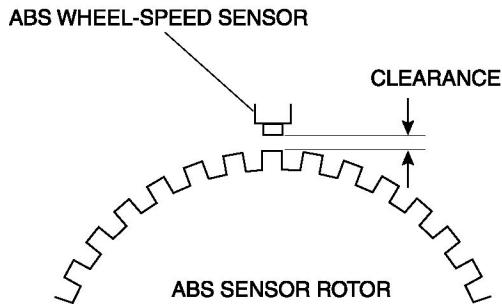

### Clearance

- 0.3—1.1 mm {0.012—0.043 in}

### Resistance Inspection

1. Measure the resistance between the ABS wheel-speed sensor terminals.
  - If there is any malfunction, replace the ABS wheel-speed sensor.

### Standard

- 1.3—1.7 kilohms

### Voltage Pattern Inspection

1. Lift up the vehicle, and connect an oscilloscope to the ABS wheel-speed sensor connector.
2. While rotating each wheel by hand inspect the voltage pattern.
  - If there is distortion or noise, inspect the sensor rotor.

### Voltage pattern (reference)

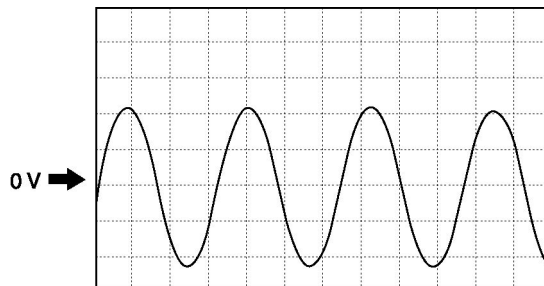

- Oscilloscope setting:  
1 V/DIV (Y), 2 ms/DIV (X), AC range
- Vehicle condition: Driving **30 km/h (18.6 mph)**

### NOTE:

- As the vehicle speed increases, the voltage increases and the wave period shortens.

### Sensor Output Value Inspection

1. Turn the ignition switch off.
2. Connect the WDS or equivalent to the DLC-2.



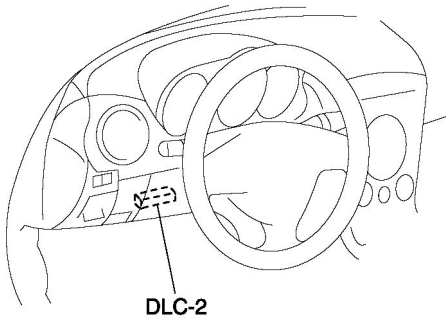

3. Select the following PIDs using the WDS or equivalent:
  - LR\_WSPD  
(LR wheel-speed sensor)
  - RR\_WSPD  
(RR wheel-speed sensor)
4. Start the engine and drive the vehicle.
5. Verify that the display of the WDS or equivalent shows the same value as the speedometer.
  - If there is any malfunction, replace the ABS wheel-speed sensor.

# DYNAMIC STABILITY CONTROL

## DYNAMIC STABILITY CONTROL LOCATION INDEX

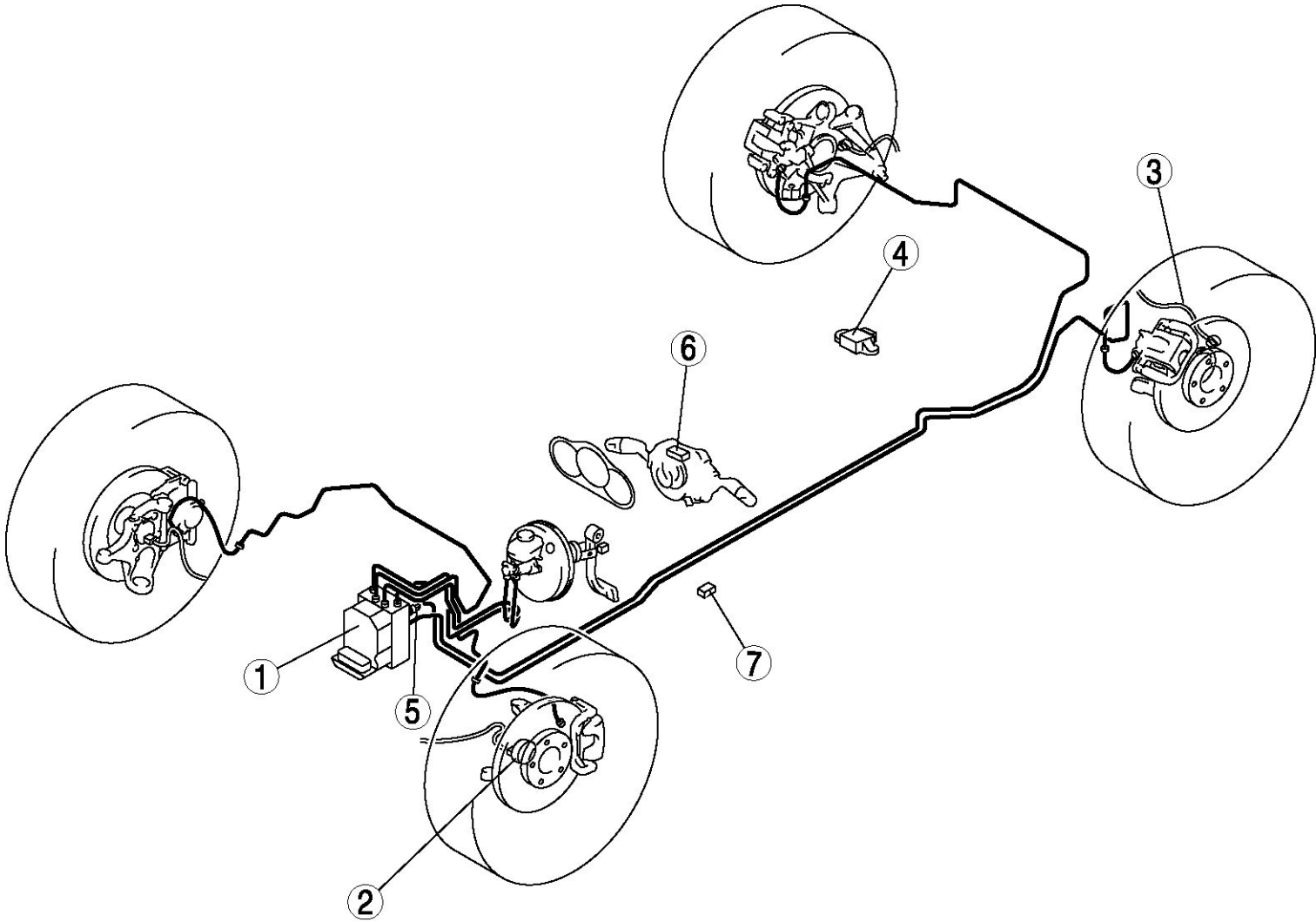

1	DSC HU/CM
2	Front ABS wheel-speed sensor
3	Rear ABS wheel-speed sensor
4	Combined sensor
5	Brake fluid pressure sensor
6	Steering angle sensor
7	DSC OFF switch

# DSC SYSTEM DIAGRAM

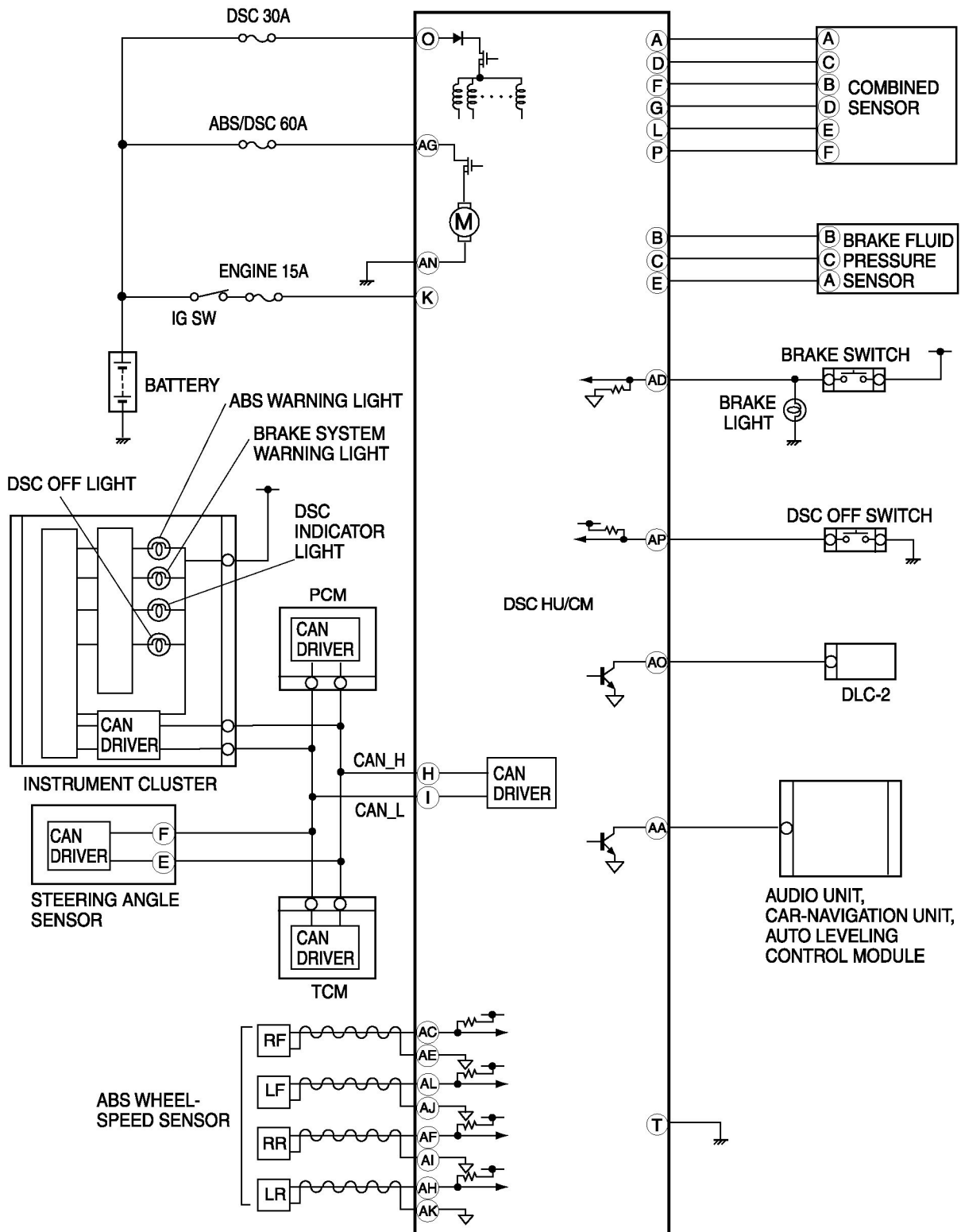

# DSC SYSTEM INSPECTION

## Preparation

1. Verify that battery is fully charged.
2. Turn the ignition switch to the ON position, and verify that the ABS warning light goes out after **approx. 3 s**.
3. Turn the ignition switch off.
4. Jack up the vehicle and support it evenly on safety stands.
5. Shift to the N position.
6. Verify that all four wheels rotate.
7. Rotate the inspected wheels by hand, and verify there is no brake drag.
  - If there is any brake drag, perform regular brake inspection.
  - If there is no brake drag, perform DSC HU/CM operation inspection.

## ABS Control Inspection

1. Perform "Preparation".
2. Connect the WDS or equivalent to the DLC-2.

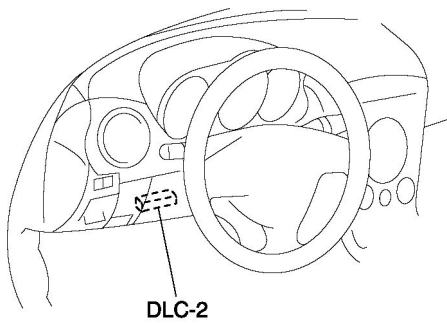

3. Set up an active command mode inspection according to the combination of commands below. Brake pressure retention

Command name	Inspected wheels			
	LF	RF	LR	RR
LF_TC_VLV	OFF			
RF_TC_VLV				
LF_DSC_V				
RF_DSC_V				
ABS_POWER	ON			
LF_INLET	ON	OFF	OFF	OFF
LF_OUTLET	OFF		ON	
LR_INLET	OFF	OFF	OFF	
LR_OUTLET		ON		
RF_INLET	OFF	ON	ON	
RF_OUTLET		OFF		
RR_INLET				ON

RR_OUTLET				OFF
PMP_MOTOR				

#### 4. Brake pressure reduction

Command name	Inspected wheels			
	LF	RF	LR	RR
LF_TC_VLV	OFF			
RF_TC_VLV				
LF_DSC_V				
RF_DSC_V				
ABS_POWER	ON			
LF_INLET	ON	OFF	OFF	OFF
LF_OUTLET			ON	
LR_INLET	OFF	ON	OFF	
LR_OUTLET			ON	
RF_INLET	OFF	ON	OFF	
RF_OUTLET			ON	
RR_INLET	OFF	OFF	ON	
RR_OUTLET			ON	
PMP_MOTOR	ON			

#### 5. CAUTION:

- To protect the DSC HU/CM, the solenoid valve and the pump motor used during active command mode stay on for only 10 s or less each time they are switched on.

#### NOTE:

- When working with two people, one should press on the brake pedal, and the other should attempt to rotate the wheel being inspected.
- Send the command while depressing on the brake pedal and attempting to rotate the wheel being inspected.
  - While brake pressure is maintained and a DSC HU/CM operation click sound is heard, confirm that the wheel does not rotate. While brake pressure is being reduced and an DSC HU/CM operation click sound is heard, confirm that the wheel rotates.
    - Performing the inspection above determines the following:
      - The DSC HU/CM brake lines are normal.
      - The DSC HU/CM hydraulic system is not significantly abnormal (including DSC HU/CM).
      - The DSC HU/CM internal electrical parts (solenoid, motor and other parts) are normal.
      - The DSC unit and DSC HU/CM output system wiring harnesses (solenoid valve, relay system) are normal.
    - However, the following items cannot be verified.
      - Malfunction with intermittent occurrence of the above items
      - Malfunction of DSC HU/CM input system wiring harnesses and parts

- Extremely small leaks in the DSC HU/CM internal hydraulic system

## DSC Control Inspection

1. Perform "Preparation".
2. Connect the WDS or equivalent to the DLC-2.

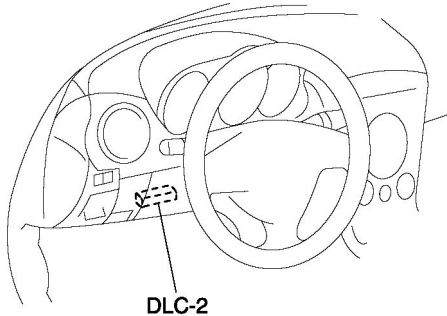

3. Set up an active command mode inspection according to the combination of commands below.

### CAUTION:

- To protect the DSC HU/CM, the solenoid valve and the pump motor used during active command mode stay on for only 10 s or less each time they are switched on.

Command name	Inspected wheels				
	Understeer control inhibited		Oversteer control inhibited		
	LF	RF	LR	RR	
LF_TC_VLV	ON	OFF		ON	
RF_TC_VLV	OFF	ON		OFF	
LF_DSC_V	OFF				
RF_DSC_V	OFF				
ABS_POWER	ON				
LF_INLET	OFF	OFF	OFF	ON	
LF_OUTLET					OFF
LR_INLET		ON			
LR_OUTLET					
RF_INLET			ON		
RF_OUTLET		OFF			
RR_INLET		ON		OFF	
RR_OUTLET		OFF			
PMP_MOTOR	ON				

4. Send the command while rotating the wheel being inspected by hand in a forward direction.
5. Confirm that the wheel does not rotate easily while a DSC HU/CM operation click sound is heard.
  - Performing the inspection above determines the following:
    - The DSC HU/CM brake lines are normal.

- The DSC HU/CM hydraulic system is not significantly abnormal (including DSC HU/CM).
- The DSC HU/CM internal electrical parts (solenoid, motor and other parts) are normal.
- The DSC unit and DSC HU/CM output system wiring harnesses (solenoid valve, relay system) are normal.
- However, the following items cannot be verified.
  - Malfunction with intermittent occurrence of the above items
  - Malfunction of DSC HU/CM input system wiring harnesses and parts
  - Extremely small leaks in the DSC HU/CM internal hydraulic system

## DSC CONFIGURATION

1. Turn the ignition switch off.
2. Connect the WDS or equivalent to the DLC-2.

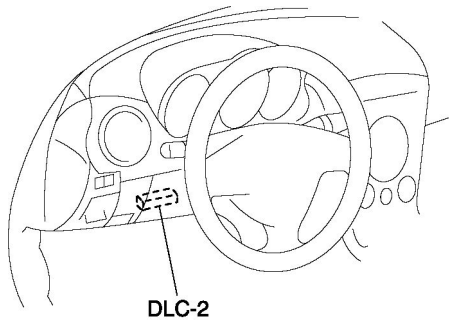

3. Input vehicle information following the directions on the screen of the WDS or equivalent.
4. Select "Module programming" from the WDS or equivalent menu.
5. Select "Programmable Module Installation".
6. Select "ABS/TCS".
7. Clear DTCs using the WDS or equivalent, then verify that there is no DTC present.

# DSC HYDRAULIC UNIT/CONTROL MODULE

## DSC HU/CM REMOVAL/INSTALLATION

### CAUTION:

- When replacing the DSC HU/CM with a new one, configuration procedure must be performed before removing the DSC HU/CM. If configuration is not completed before removing the DSC HU/CM, DTC B2477 will be detected.
- The DSC may not function normally when the DSC HU/CM is replaced. After installation, always perform the initialization procedures for the combined sensor and the steering angle sensor.
- The internal parts of the DSC HU/CM could be damaged if dropped. Be careful not to drop the DSC HU/CM. Replace the DSC HU/CM if it is subjected to an impact.

1. Perform DSC configuration.
2. Remove the front suspension tower bar.
3. Remove in the order indicated in the table.
4. Install in the reverse order of removal.

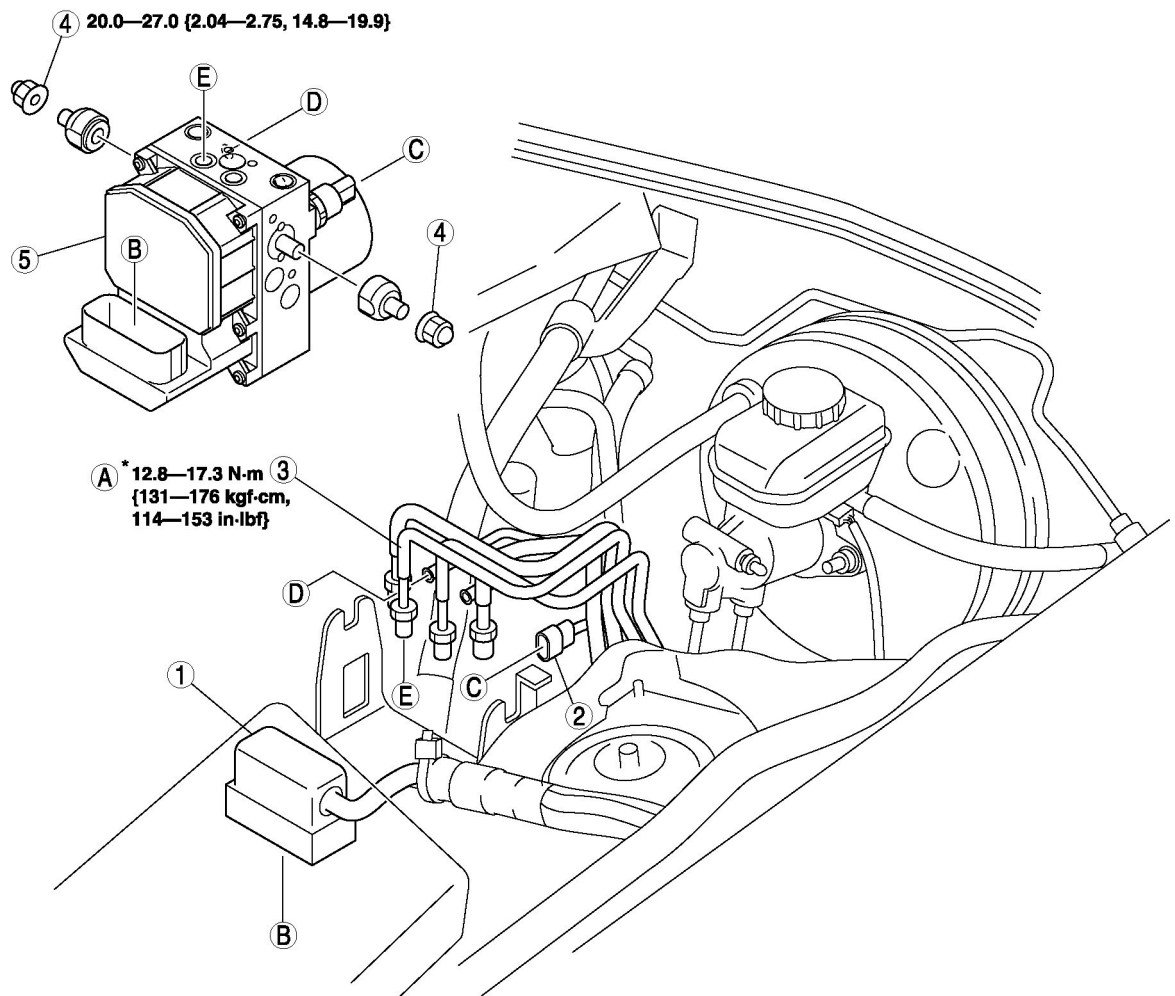

A\* COMMERCIALLY AVAILABLE FLARE NUT WRENCH  
(FLARE NUT ACROSS FLAT 12 mm {0.47 in})

N·m {kgf·m, ft·lbf}



1	Connector
2	Brake fluid pressure sensor connector
3	Brake pipe
4	Nut
5	DSC HU/CM

### Connector Removal Note

1. Rotate the lock lever in the direction of the arrow, and remove the DSC HU/CM connector.

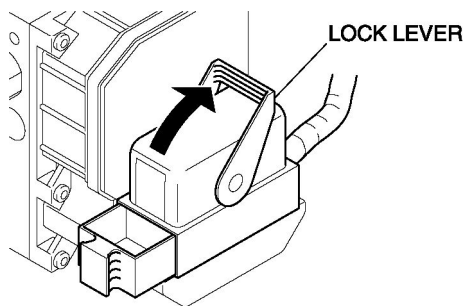

### DSC HU/CM Removal/Installation Note

1. When removing/installing the DSC HU/CM from/to the vehicle, attach a strip of protective tape on the DSC HU/CM connector to prevent brake fluid from entering.

### Connector Installation Note

1. After connecting the connector, rotate the lock lever in the direction of the arrow to install the DSC HU/CM connector.

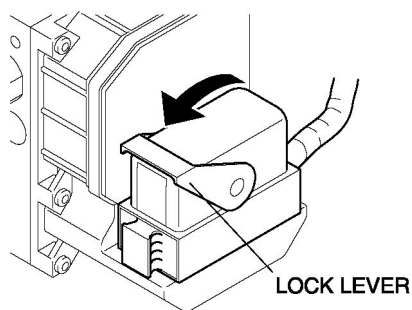

### DSC HU/CM INSPECTION

1. Disconnect the DSC HU/CM connector.
2. Connect the negative battery cable.
3. Attach the tester lead to the DSC HU/CM harness side connector, then inspect voltage, continuity or resistance according to the standard (reference value) on the table.

### Standard (Reference Value)

DSC HU/CM WIRING HARNESS-SIDE CONNECTOR

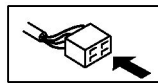
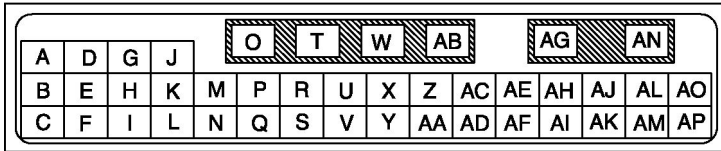

Terminal	Signal name	Connected to	Measured item	Measured terminal (measured condition)	Standard	Inspection item(s)
A	Yaw rate (reference signal)	Combined sensor	Continuity	A—combined sensor connector terminal A	Continuity detected	<ul style="list-style-type: none"> <li>Wiring harness (A—combined sensor connector terminal A)</li> </ul>
B	Brake fluid pressure (signal)	Brake fluid pressure sensor	Continuity	B—brake fluid pressure sensor connector terminal B	Continuity detected	<ul style="list-style-type: none"> <li>Wiring harness (B—brake fluid pressure sensor connector terminal B)</li> </ul>
C	Power supply (brake fluid pressure sensor)	Brake fluid pressure sensor	Continuity	C—brake fluid pressure sensor connector terminal C	Continuity detected	<ul style="list-style-type: none"> <li>Wiring harness (C—brake fluid pressure sensor connector terminal C)</li> </ul>
D	Yaw rate (test signal)	Combined sensor	Continuity	D—combined sensor connector terminal C	Continuity detected	<ul style="list-style-type: none"> <li>Wiring harness (D—combined sensor connector terminal C)</li> </ul>
E	Ground (brake fluid pressure sensor)	Brake fluid pressure sensor	Continuity	E—brake fluid pressure sensor connector terminal A	Continuity detected	<ul style="list-style-type: none"> <li>Wiring harness (E—brake fluid</li> </ul>

						pressure sensor connector terminal A)
F	Yaw rate (signal)	Combined sensor	Continuity	F—combined sensor connector terminal B	Continuity detected	<ul style="list-style-type: none"> <li>Wiring harness (F—combined sensor connector terminal B)</li> </ul>
G	Lateral-G (signal)	Combined sensor	Continuity	G—combined sensor connector terminal D	Continuity detected	<ul style="list-style-type: none"> <li>Wiring harness (G—combined sensor connector terminal D)</li> </ul>
H	CAN_H	DLC-2 (CAN_H)	Continuity	H—DLC-2 terminal CAN_H	Continuity detected	<ul style="list-style-type: none"> <li>Wiring harness (H—DLC-2 terminal CAN_H)</li> </ul>
I	CAN_L	DLC-2 (CAN_L)	Continuity	I—DLC-2 terminal CAN_L	Continuity detected	<ul style="list-style-type: none"> <li>Wiring harness (I—DLC-2 terminal CAN_L)</li> </ul>
J	—	—	—	—	—	—
K	Power supply (system)	Ignition switch	Voltage	Ignition switch at ON	B+	<ul style="list-style-type: none"> <li>Wiring harness (K—ignition switch)</li> </ul>
				Ignition switch is off.	1 V or less	—
L	Power supply (combined sensor)	Combined sensor	Continuity	L—combined sensor connector terminal E	Continuity detected	<ul style="list-style-type: none"> <li>Wiring harness (L—combined sensor)</li> </ul>

						connector terminal E)
M	—	—	—	—	—	—
N	—	—	—	—	—	—
O	Power supply (solenoid operation)	Battery	Voltage	Under any condition	B+	<ul style="list-style-type: none"> <li>Wiring harness (O—battery)</li> </ul>
P	Ground (combined sensor)	Combined sensor	Continuity	P—combined sensor connector terminal F	Continuity detected	<ul style="list-style-type: none"> <li>Wiring harness (P—combined sensor connector terminal F)</li> </ul>
Q	—	—	—	—	—	—
R	—	—	—	—	—	—
S	—	—	—	—	—	—
T	Ground (DSC system)	Ground point	Continuity	T—ground point	Continuity detected	<ul style="list-style-type: none"> <li>Wiring harness (T—ground point)</li> </ul>
U	—	—	—	—	—	—
V	—	—	—	—	—	—
W	—	—	—	—	—	—
X	—	—	—	—	—	—
Y	—	—	—	—	—	—
Z	—	—	—	—	—	—
AA	Vehicle speed output	Audio unit	Continuity	AA—audio unit	Continuity detected	<ul style="list-style-type: none"> <li>Wiring harness (AA—audio unit)</li> </ul>
		Car-navigation unit		AA—car-navigation unit		<ul style="list-style-type: none"> <li>Wiring harness (AA—car-navigation unit)</li> </ul>

		Auto leveling control module		AA—auto leveling control module		<ul style="list-style-type: none"> <li>Wiring harness (AA—auto leveling control module)</li> </ul>
AB	—	—	—	—	—	—
AC	RF wheel-speed sensor (signal)	RF ABS wheel-speed sensor	Continuity	AC—RF ABS wheel-speed sensor connector terminal A	Continuity detected	<ul style="list-style-type: none"> <li>Wiring harness (AC—RF ABS wheel-speed sensor connector terminal A)</li> </ul>
AD	Brake switch	Brake switch	Voltage	AD—ground point (Brake pedal depressed with ignition switch at ON)	B+	<ul style="list-style-type: none"> <li>Wiring harness (AD—brake switch)</li> <li>Brake switch</li> </ul>
				AD—ground point (Brake pedal not depressed with ignition switch at ON)	1 V or less	—
AE	RF wheel-speed sensor (ground)	RF ABS wheel-speed sensor	Continuity	AE—RF ABS wheel-speed sensor connector terminal B	Continuity detected	<ul style="list-style-type: none"> <li>Wiring harness (AE—RF ABS wheel-speed sensor connector terminal B)</li> </ul>
AF	RR wheel-speed (signal)	RR ABS wheel-speed sensor	Continuity	AF—RR ABS wheel-speed sensor connector terminal A	Continuity detected	<ul style="list-style-type: none"> <li>Wiring harness (AF—RR ABS wheel-speed sensor connector terminal A)</li> </ul>

AG	Power supply (ABS motor operation)	Battery	Voltage	Under any condition	B+	<ul style="list-style-type: none"> <li>Wiring harness (AG—battery)</li> </ul>
AH	LR wheel-speed sensor (signal)	LR ABS wheel-speed sensor	Continuity	AH—LR ABS wheel-speed sensor connector terminal A	Continuity detected	<ul style="list-style-type: none"> <li>Wiring harness (AH—LR ABS wheel-speed sensor connector terminal A)</li> </ul>
AI	RR wheel-speed sensor (ground)	RR ABS wheel-speed sensor	Continuity	AI—RR ABS wheel-speed sensor connector terminal B	Continuity detected	<ul style="list-style-type: none"> <li>Wiring harness (AI—RR ABS wheel-speed sensor connector terminal B)</li> </ul>
AJ	LF wheel-speed sensor (ground)	LF ABS wheel-speed sensor	Continuity	AJ—LF ABS wheel-speed sensor connector terminal B	Continuity detected	<ul style="list-style-type: none"> <li>Wiring harness (AJ—LF ABS wheel-speed sensor connector terminal B)</li> </ul>
AK	LR wheel-speed sensor (ground)	LR ABS wheel-speed sensor	Continuity	AK—LR ABS wheel-speed sensor connector terminal B	Continuity detected	<ul style="list-style-type: none"> <li>Wiring harness (AK—LR ABS wheel-speed sensor connector terminal B)</li> </ul>
AL	LF wheel-speed sensor (single)	LF ABS wheel-speed sensor	Continuity	AL—LF ABS wheel-speed sensor connector terminal A	Continuity detected	<ul style="list-style-type: none"> <li>Wiring harness (AL—LF ABS wheel-speed sensor connector)</li> </ul>

						terminal A)
AM	—	—	—	—	—	—
AN	Ground (ABS motor)	Ground point	Continuity	AN—ground point	Continuity detected	<ul style="list-style-type: none"> <li>Wiring harness (AN—ground point)</li> </ul>
AO	KLN	DLC-2 (KLN)	Continuity	AO—DLC-2 terminal KLN	Continuity detected	<ul style="list-style-type: none"> <li>Wiring harness (AO—DLC-2 terminal KLN)</li> </ul>
AP	DSC OFF switch	DSC OFF switch	Continuity	AP—DSC OFF switch connector terminal C	Continuity detected	<ul style="list-style-type: none"> <li>Wiring harness (AP—DSC OFF switch connector terminal C)</li> </ul>

# FRONT ABS WHEEL-SPEED SENSOR

## FRONT ABS WHEEL-SPEED SENSOR REMOVAL/INSTALLATION

1. Remove or install the front ABS wheel-speed sensor in the same order of vehicles with ABS.

## FRONT ABS WHEEL-SPEED SENSOR INSPECTION

1. Inspect the front ABS wheel-speed sensor in the same order of vehicles with ABS.

# REAR ABS WHEEL-SPEED SENSOR

## REAR ABS WHEEL-SPEED SENSOR REMOVAL/INSTALLATION

1. Remove or install the rear ABS wheel-speed sensor in the same order of vehicles with ABS.

## REAR ABS WHEEL-SPEED SENSOR INSPECTION

1. Inspect the rear ABS wheel-speed sensor in the same order of vehicles with ABS.

# COMBINED SENSOR

## COMBINED SENSOR REMOVAL/INSTALLATION

### CAUTION:

- The internal parts of the combined sensor could be damaged if dropped. Be careful not to drop the combined sensor. Replace the combined sensor if it is subjected to an impact. Also, do not use an impact wrench or other similar air tools when removing/installing the sensor.
1. Remove the rear console.
  2. Remove in the order indicated in the table.

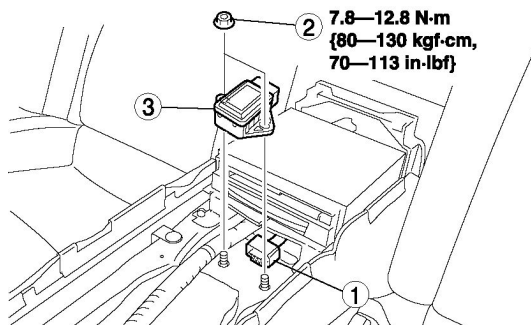

1	Combined sensor connector
2	Nut
3	Combined sensor

3. Install in the reverse order of removal.



4. After installation, perform the combined sensor initialization procedure.

## COMBINED SENSOR INSPECTION

1. Turn the ignition switch off.
2. Connect the WDS or equivalent to the DLC-2.

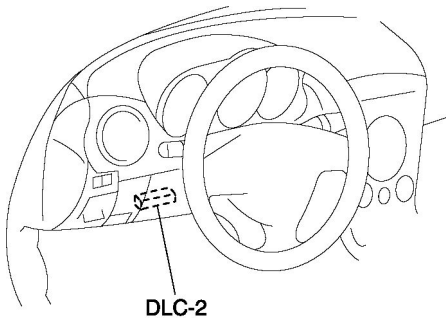

3. Select the following PIDs, then inspect the lateral acceleration speed and the yaw rate.
  - LAT ACC: (lateral acceleration speed)
  - YAW\_RATE: (yaw rate)
- c. Lateral acceleration speed inspection
  1. Verify the LAT ACC change when the combined sensor is tilted to the left and right.

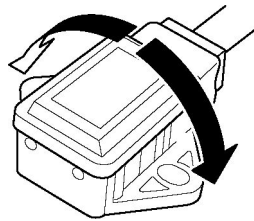

- If there is any malfunction, replace the combined sensor.

### Standard

- When the sensor is tilted to the right:

LAT ACC changes negatively.

- When the sensor is tilted to the left:

LAT ACC changes positively.

- d. Yaw rate inspection

1. Verify the YAW\_RATE change when the combined sensor is rotated to the left and right.

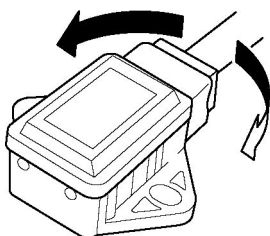

- If there is any malfunction, replace the combined sensor.

### **Standard**

- When the sensor is rotated to the right:  
YAW\_RATE changes negatively.
- When the sensor is rotated to the left:  
YAW\_RATE changes positively.

## **COMBINED SENSOR INITIALIZATION PROCEDURE**

### **WARNING:**

- Unless the initialization procedure of the combined sensor is completed, the DSC will not operate, causing an unexpected accident. Therefore, always perform the initialization procedure to ensure DSC operation if the combined sensor and DSC HU/CM have been removed or replaced.
1. Inspect the wheel alignment and inflation pressure.
    - If there is any malfunction, adjust the applicable part.
  2. Park the vehicle on level ground.
  3. Turn the ignition switch off.
  4. Connect the WDS or equivalent to the DLC-2.

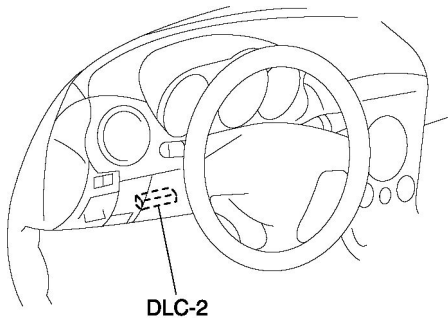

5. Access the active command mode, select the following commands, and then follow the indication on the monitor.
  - YAWRATE (Yaw rate)
  - LATACCEL (Lateral acceleration)
6. Drive the vehicle forward.
7. After 5 min of driving, verify that the DSC system is normal.

# BRAKE FLUID PRESSURE SENSOR

## BRAKE FLUID PRESSURE SENSOR INSPECTION

1. Turn the ignition switch to the ON position, then measure the voltage between brake fluid pressure sensor terminal C and ground.

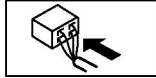
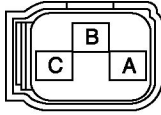

- If there is any malfunction, inspect the wiring harness between brake fluid pressure sensor terminal C and DSC HU/CM terminal C, then repair or replace if necessary.

### Standard voltage

- 4.75—5.25 V
2. Measure the voltage between brake fluid pressure sensor terminal A and the ground.
    - If there is any malfunction, inspect the wiring harness between brake fluid pressure sensor terminal A and DSC HU/CM terminal E, then repair or replace if necessary.

### Standard voltage

- 0 V
3. Turn the ignition switch off.
  4. Install the **SSTs** to the master cylinder.

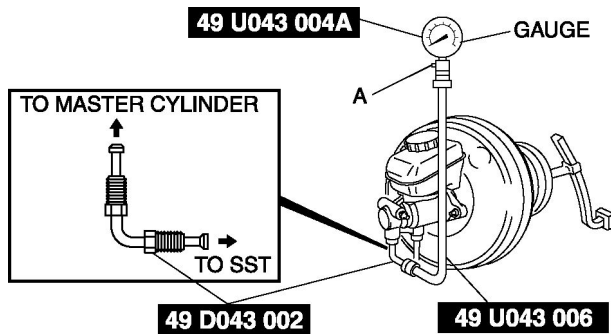

### NOTE:

- Install the **SST** (49 D043 002) to the master cylinder using a commercially available flare nut wrench.
    - Flare nut across flat: **12 mm {0.47 in}**
5. Bleed the air from the **SSTs** and the brake line. (Bleed air from the **SSTs** through air bleeding valve A.)
  6. Connect the WDS or equivalent to the DLC-2.

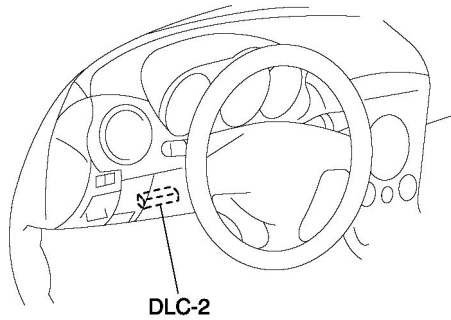

7. Select the MCYLIP PID.
8. Start the engine.
9. Depress the brake pedal, and confirm that the fluid pressure value of the SST (Gauge) and the value shown on the WDS or equivalent are equal.
  - If the fluid pressures are different, replace the DSC HU/CM.

## STEERING ANGLE SENSOR

### STEERING ANGLE SENSOR REMOVAL/INSTALLATION

#### NOTE:

- The steering angle sensor is integrated into the combination switch to ensure sensor performance. Replace the steering angle sensor and combination switch as a single unit. (See [COMBINATION SWITCH REMOVAL/INSTALLATION](#).)

### STEERING ANGLE SENSOR INSPECTION

1. Remove the column cover.
2. Measure the voltage between steering angle sensor terminal B and ground.

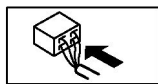
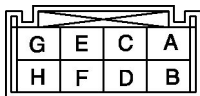

- If there is any malfunction, inspect the wiring harness between steering angle sensor terminal B and battery, then repair or replace if necessary.

#### Standard voltage

- B+
3. Turn the ignition switch to the ON position, then measure the voltage between steering angle sensor terminal A and ground.
    - If there is any malfunction, inspect the wiring harness between steering angle sensor terminal A and ignition switch, then repair or replace if necessary.

#### Standard voltage

- B+
4. Measure the voltage between steering angle sensor terminal H and the ground.
    - If there is any malfunction, inspect the wiring harness between steering angle sensor terminal H and ground point, then repair or replace if necessary.

**Standard voltage**

- 0 V
5. Turn the ignition switch off.
  6. Connect the WDS or equivalent to the DLC-2.

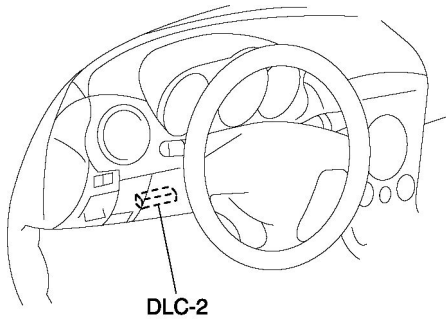

7. Select the SWA POS PID.
8. Verify the SWA POS changes when the steering wheel is turned to the left and right.
  - If there is any malfunction, replace the steering angle sensor.

**Standard**

- When the steering wheel is turned to the right:  
SWA POS changes positively.
- When the steering wheel is turned to the left:  
SWA POS changes negatively.

## STEERING ANGLE SENSOR INITIALIZATION PROCEDURE

### WARNING:

- Unless the initialization procedure of the steering angle sensor is completed, the DSC will not operate, causing an unexpected accident. Therefore, always perform the initialization procedure to ensure DSC operation if the power supply to the steering angle sensor has been cut off due to disconnection of the steering angle sensor connector or negative battery cable, or any other cause.

### NOTE:

- The steering angle sensor requires battery power to store the steering angle initial position. Therefore when the battery power supply is cut off, a stored steering angle initial position is cleared.
1. Inspect the wheel alignment, inflation pressure, and the installation condition of the steering wheel.
    - If there is any malfunction, adjust the applicable part.
  2. Connect the negative battery cable.
  3. Turn the ignition switch to the ON position.
  4. Confirm that the DSC indicator light illuminates and that the DSC OFF light flashes.
  5. Turn the steering wheel to full right lock, then turn it to full left lock.
  6. Confirm that the DSC OFF light goes out.
  7. Turn the ignition switch off.
  8. Turn the ignition switch to the ON position again, and confirm that the DSC indicator light goes out.
    - If the DSC indicator light does not go out, disconnect the negative battery cable, and perform the procedure again starting from Step 2 shown above.
  9. Drive the vehicle for **approx. 10 min**, and confirm that the ABS warning and DSC indicator lights do not illuminate.

## DSC OFF SWITCH

### DSC OFF SWITCH REMOVAL/INSTALLATION

1. Remove in the order indicated in the table.

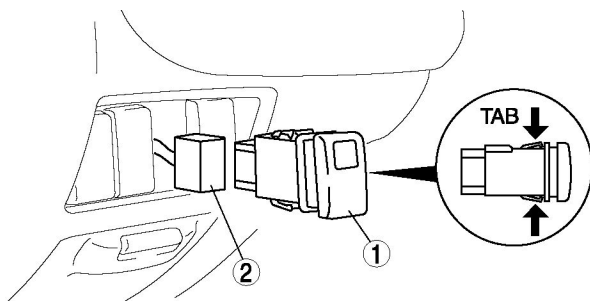

1	DSC OFF switch (See <a href="#">DSC OFF Switch Removal Note</a> .)
2	Connector



2. Install in the reverse order of removal.







## DSC OFF Switch Removal Note

1. Access the DSC OFF switch from behind of the dashboard, and squeeze the tabs of the switch.
2. Pull the DSC OFF switch towards the driver's side to remove it.

## DSC OFF SWITCH INSPECTION

1. Remove the DSC OFF switch.
2. Verify that the continuity is as indicated in the table.
  - If not as indicated in the table, replace the DSC OFF switch.

 : Bulb   
  : Continuity

Condition	Terminal			
	A	B	C	D
Switch pressed				
Switch released				

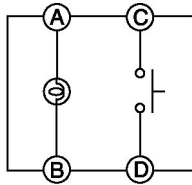
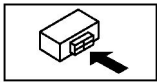

# PARKING BRAKE SYSTEM

## PARKING BRAKE SYSTEM LOCATION INDEX

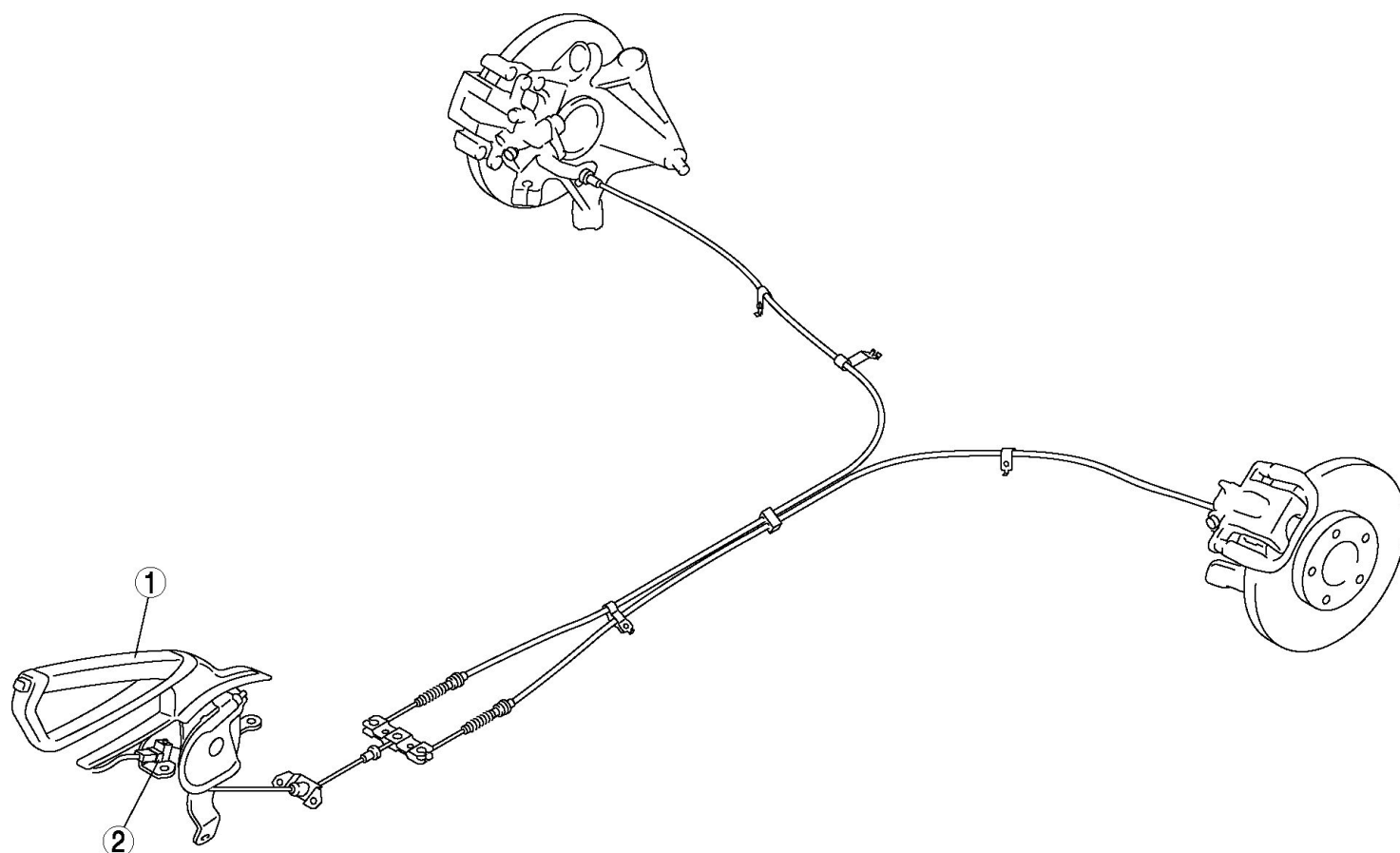

1	Parking brake lever
2	Parking brake switch



# PARKING BRAKE LEVER

## PARKING BRAKE LEVER INSPECTION

### Stroke Inspection

1. Depress the brake pedal several times.
2. Pull the parking brake lever **2—3 times** .
3. Inspect the parking brake stroke by slowly pulling at point A **50 mm {1.97 in}** from the end of the parking brake lever with a force of **98 N {10 kgf, 22 lbf}** and counting the number of notches (clicking sound).

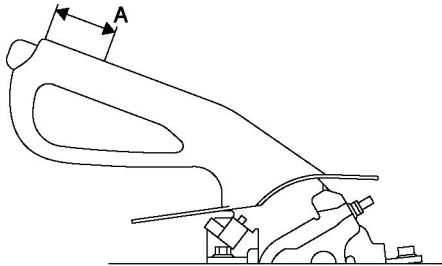

- If not within the specification, adjust the parking brake lever.

### Standard

- 1—3 notches

## PARKING BRAKE LEVER ADJUSTMENT

1. Depress the brake pedal several times.
2. Remove the service hole cover of the rear console.

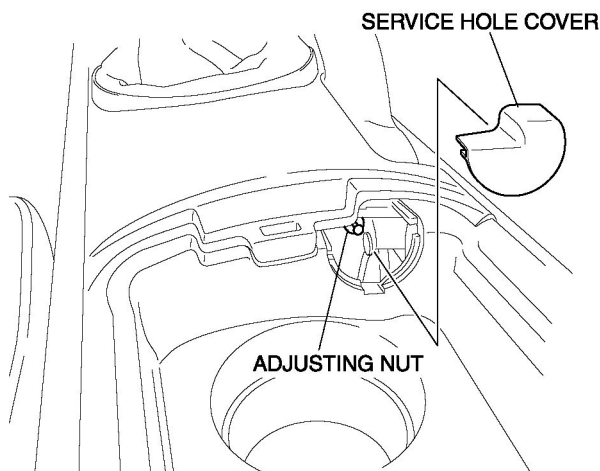

3. Turn the adjusting nut and adjust the parking brake lever.
4. After adjustment, pull the parking brake lever one notch and verify that the parking brake warning light illuminates.
5. Verify that the rear brakes do not drag.

## PARKING BRAKE LEVER REMOVAL/INSTALLATION

1. Remove the propeller shaft.
2. Remove the front console.
3. Remove in the order indicated in the table.
4. Install in the reverse order of removal.
5. After installation, inspect the parking brake stroke and adjust if necessary.

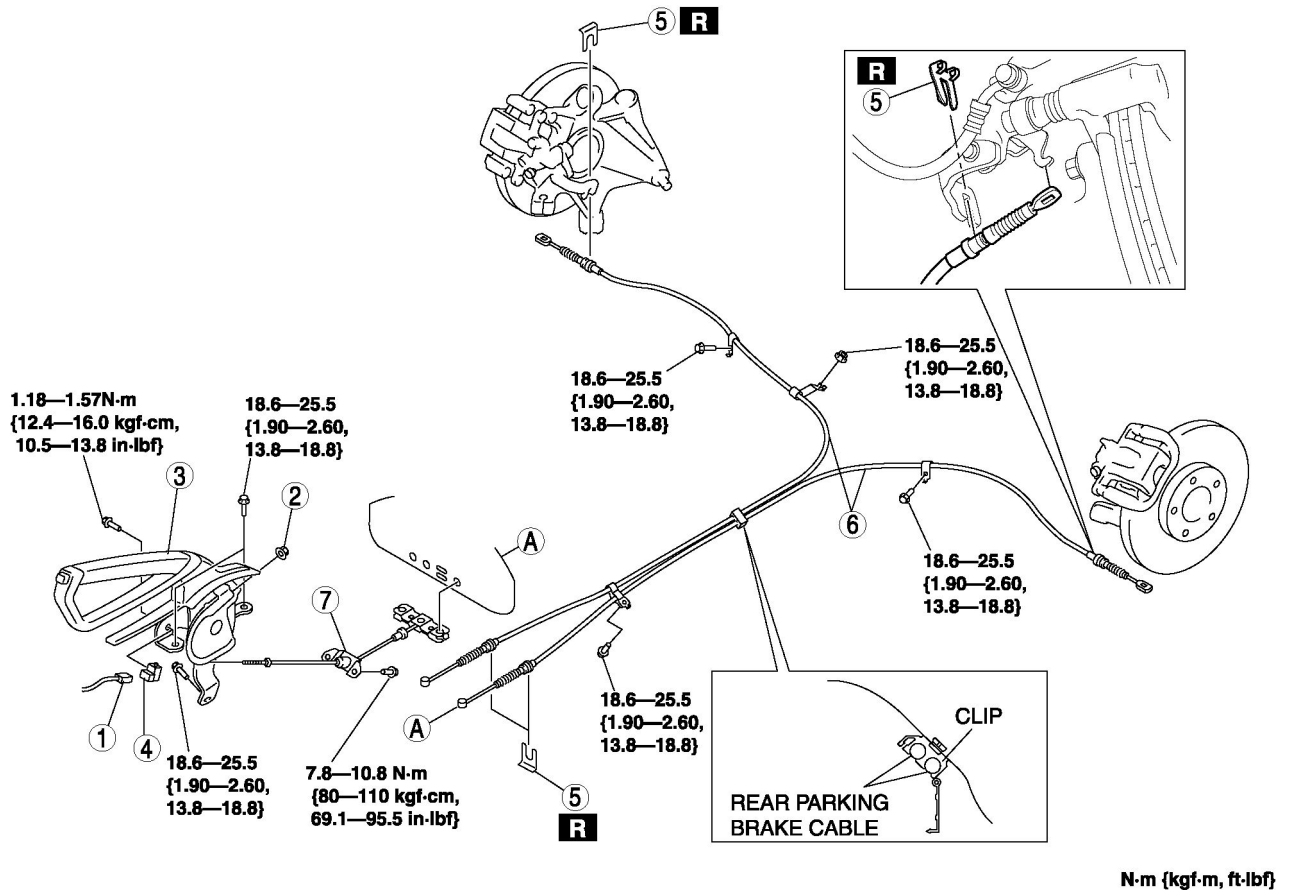

1	Parking brake switch connector
2	Adjusting nut
3	Parking brake lever
4	Parking brake switch
5	Clip
6	Rear parking brake cable
7	Front parking brake cable



# PARKING BRAKE SWITCH

## PARKING BRAKE SWITCH INSPECTION

1. Disconnect the parking brake switch connector.
2. Verify that the continuity is as indicated in the table.
  - If not as indicated in the table, replace the parking brake switch.

○—○: Continuity

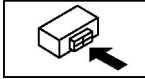
Condition	Terminal	
	A	Body ground
Parking brake lever pulled	○—○	
Parking brake lever released		



Notes:

## PRECAUTION

### Vehicle with ABS

1. Any one or a combination of the ABS warning and BRAKE system warning lights illuminate even when the system is normal.

Warning lights that may illuminate and/or flash	Condition under which the light may illuminate	Conditions under which the light will go out	ABS, EBD control
<p>Any or all the following lights illuminate:</p> <ul style="list-style-type: none"> <li>• ABS warning light</li> <li>• BRAKE system warning light (*1)</li> </ul>	<p>Under any of the following conditions:</p> <ul style="list-style-type: none"> <li>• When the front wheels are jacked up, stuck, or placed on a chassis roller, and only the front wheel ABS wheel speed sensors are spun for <b>20 s or more</b>.</li> </ul>	<p>After turning ignition switch off, vehicle is driven at speed <b>greater than 10 km/h {6.2 mph}</b> and normal operation is confirmed.</p>	<ul style="list-style-type: none"> <li>• ABS: Disables control.</li> <li>• EBD:               <ol style="list-style-type: none"> <li>1. Disable control, in cases where the light may illuminate, only when ABS HU/CM detects that wheel speed sensors determine that two or more rear wheels are malfunctioning.</li> <li>2. Enables control, if wheel speed sensors determine that three or more wheels are functioning correctly.</li> </ol> </li> </ul>
	Parking brake is not fully released while driving.		
	Brake drag.		
	Sudden acceleration/deceleration.		
	Left/right or front/rear tires are different. (Size, radius, tire pressure, or wear is other than that listed on tire label.)		
<p>All the following lights illuminate:</p> <ul style="list-style-type: none"> <li>• ABS warning light</li> <li>• BRAKE system warning light</li> </ul>	<p>Battery voltage at ABS HU/CM ignition terminal Z drops <b>below approx. 9 to 10 V.</b> (*2)</p>	<p>Battery voltage rises <b>above approx. 10 V.</b> (Only BRAKE system warning light goes out.)</p>	<p>ABS: Enables control. EBD: Enables control.</p>

2. \* 1

3. The light will illuminate only when ABS HU/CM detects that a rear wheel-speed sensor is malfunctioning.

4. \* 2

5. If battery voltage drops **below 9 V** while vehicle speed is **greater than 6 km/h {3.7 mph}** , the ABS HU/CM stores DTC B1318.
6. Precautions during servicing of ABS

The ABS is composed of electrical and mechanical parts. It is necessary to categorize malfunctions as being either electrical or hydraulic when performing troubleshooting.

a. Malfunctions in electrical system

- The ABS HU/CM has an on-board diagnostic function. With this function, any one or a combination of the ABS warning light and BRAKE system warning light will illuminate when there is a problem in the electrical system. Also, past and present malfunctions are stored in the ABS HU/CM. This function can find malfunctions that do not occur during periodic inspections. Connect the WDS or equivalent to the DLC-2. Stored malfunctions will be displayed in the order of occurrence. To find out the causes of ABS malfunctions, use these on-board diagnostic results.
- If a malfunction occurred in the past but is now normal, the cause is likely a temporary poor connection of the wiring harness. The ABS HU/CM usually operates normally. Be careful when searching for the cause of malfunction.
- After repair, it is necessary to clear the

DTC from the ABS HU/CM memory. Also, if the ABS related parts have been replaced, verify that no DTC is displayed after repairs.

- After repairing the ABS wheel-speed sensor or ABS sensor rotor, or after replacing the ABS HU/CM, the ABS warning light may not go out ( \* ) even when the ignition switch is turned to the ON position. In this case, drive the vehicle at a speed of **10 km/h {6.2 mph} or more** , make sure that ABS warning light goes out, and then clear the DTC.

\* The BRAKE system warning light also illuminates when there is any rear wheel deformation.

- When repairing, if the ABS related connectors are disconnected and the ignition switch is turned to the ON position, the ABS HU/CM will mistakenly detect a fault and record it as a malfunction.
- To protect the ABS HU/CM, make sure the ignition is off before connecting or disconnecting the ABS HU/CM connector.

b. Malfunctions in hydraulic system

- Symptoms in a hydraulic system malfunction are similar to those in a conventional brake malfunction. However, it is necessary to determine if the malfunction is in an ABS component or the conventional brake system.
- The ABS hydraulic unit contains delicate mechanical parts. If foreign material gets into the component, the ABS may fail to operate. Also, it will likely become extremely difficult to find the location of the malfunction in the event that the brakes operate but the ABS does not. Make sure foreign material does not enter when servicing the ABS (e.g. brake fluid replacement, pipe removal).

## Vehicle with DSC

1. The ABS warning light and/or BRAKE system warning light and/or DSC indicator light and/or DSC OFF light illuminate even when the system is normal.

Warning lights that may illuminate and/or flash	Condition under which the light may illuminate	Conditions under which the light will go out	ABS, EBD, TCS and DSC control
<ul style="list-style-type: none"> <li>• ABS warning light</li> <li>• BRAKE system warning light</li> <li>• DSC indicator light</li> </ul>	Under any of the following conditions: <ul style="list-style-type: none"> <li>• When the front wheels are jacked up, struck, or placed on a chassis roller, and only the front wheel ABS wheel speed sensors are spun for <b>20 s or more</b>.</li> </ul>	After turning ignition switch off, vehicle is driven at speed <b>greater than 10 km/h {6.2 mph}</b> and normal operation is confirmed.	<ul style="list-style-type: none"> <li>• ABS: Disables control.</li> <li>• EBD:               <ol style="list-style-type: none"> <li>1. Disable control, in cases where the light may illuminate, only when ABS HU/CM detects that wheel speed sensors determine that two or more wheels are malfunctioning.</li> <li>2. Enables control, if wheel speed sensors determine three or more wheels are functioning correctly.</li> </ol> </li> <li>• TCS: Disables control.</li> <li>• DSC: Disables control.</li> </ul>
	Parking brake is not fully released while driving.		
	Brake drag.		
	Sudden acceleration/deceleration.		
Left/right or front/rear tires are different. (Size, radius, tire pressure, or wear is other than that listed on tire label.)			
	Battery voltage at DSC HU/CM ignition terminal drops <b>below approx. 10 V.</b>	Battery voltage rises <b>above approx. 10 V.</b>	ABS: Disables control. EBD: Enables control. TCS: Disables control. DSC: Disables control.
<ul style="list-style-type: none"> <li>• Brake system warning light</li> </ul>	Brake fluid amount is low.	Brake fluid level lower than recommended amount.	ABS: Enables control. EBD: Enables control. TCS: Enables control. DSC: Enables control.

## 2. Precautions during servicing of DSC

The DSC is composed of electrical and mechanical parts. It is necessary to categorize malfunctions as being either electrical or hydraulic when performing troubleshooting.

a. Malfunction in electrical system

- The control module has an on-board diagnostic function. With this function, the ABS warning light and/or BRAKE system warning light and/or DSC indicator light and/or DSC OFF light will illuminate when there is a problem in the electrical system.

Also, past and present malfunctions are in the control module. This function can find malfunctions that do not occur during periodic inspections. Connect the WDS or equivalent to the DLC-2, the stored malfunctions will be displayed in the order of occurrence. To find out the causes of DSC malfunctions, use these on-board diagnostic results.

- If a malfunction occurred in the past but is now normal, the cause is likely a temporary poor connection of the wiring harness.

The control module usually operates normally. Be careful when searching for the cause of malfunction.

- After repair, it is necessary to clear the DTC from the control module memory.

Also, if the DSC related parts have been replaced, verify that no DTC is displayed after repairs.

- After repairing the ABS wheel-speed sensor or ABS sensor rotor, or after replacing the control module, the ABS warning light may not go out even when the ignition switch is turned to the ON position. In this case, drive the vehicle at a speed of **more than 10 km/h {6.2 mph}**, make sure the ABS warning light goes out, and then clear the DTC.
- When repairing, if the DSC related connectors are disconnected and the ignition switch is turned to the ON position, the control module will mistakenly detect a fault and record it as a malfunction.

**CAUTION:**

- In DSC vehicles, when the DSC HU/CM, steering angle sensor, or combined sensor is replaced, perform the initialization procedure for each sensor.
- To protect the control module, make sure the ignition is off before connecting or disconnecting the control module connector.

b. Malfunctions in hydraulic system

- Symptoms in a hydraulic system malfunction are similar to those in a conventional brake malfunction. However, it is necessary to determine if the malfunction is in a DSC component or the conventional brake system.
- The hydraulic unit contains delicate mechanical parts. If foreign material gets into the component, the DSC may fail to operate. Also, it will likely become extremely difficult to find the location of the malfunction in the event that the brakes operate but the DSC does not. Make sure foreign material does not enter when servicing the DSC (e.g. brake fluid replacement, pipe removal).

## Intermittent Concern Troubleshooting

### Vibration method

- If a malfunction occurs or becomes worse while driving on a rough road or when the engine is vibrating, perform the following steps.

## NOTE:

- There are several reasons why vehicle or engine vibration could cause an electrical malfunction. Inspect the following:
  - Connectors not fully seated.
  - Wire harnesses not having full play.
  - Wires laying across brackets or moving parts.
  - Wires routed too close to hot parts.
- An improperly routed, improperly clamped, or loose harness can cause wiring to become pinched between parts.
- The connector joints, points of vibration, and places where wiring harnesses pass through the firewall, body and other panels are the major areas to be inspected.

### Inspection method for switch connectors or wires

1. Connect the WDS or equivalent to DLC-2.
2. Turn the ignition switch to the ON position (engine off).

## NOTE:

- If the engine starts and runs, perform the following steps at idle.
3. Access PIDs for the switch you are inspecting.
  4. Turn the switch on manually.
  5. Slightly shake each connector or wiring harness vertically and horizontally while monitoring the PID.

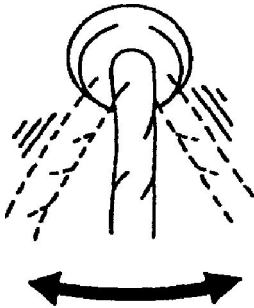

- If the PID value is unstable, inspect for poor connection.

### Inspection method for sensor connectors or wires

1. Connect the WDS or equivalent to the DLC-2.
2. Turn the ignition switch to the ON position (engine off).

## NOTE:

- If the engine starts and runs, perform the following steps at idle.
3. Access PIDs for the switch you are inspecting.
  4. Slightly shake each connector or wiring harness vertically and horizontally while monitoring the PID.



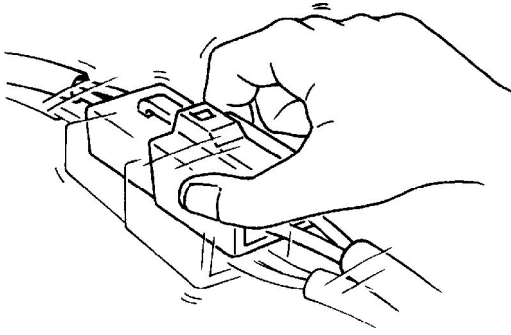

- If the PID value is unstable, inspect for poor connection.

#### **Inspection method for sensors**

1. Connect the WDS or equivalent to DLC-2.
2. Turn the ignition switch to the ON position (engine off).

#### **NOTE:**

- If engine starts and runs, perform the following steps at idle.
3. Access PIDs for the switch you are inspecting.
4. Vibrate the sensor slightly with your finger.
  - If the PID value is unstable or a malfunction occurs, inspect for poor connection and/or poorly mounted sensor.

#### **Malfunction data monitor method**

1. Perform the malfunction reappearance test according to malfunction reappearance mode and malfunction data monitor. The malfunction cause is found in the malfunction data.

#### **Inspection method for connector terminal**

1. Inspect the connection condition of each female terminal.
2. Insert the male terminal, and fit the female terminal side to female terminal. Inspect if the malfunction is in the female terminal.

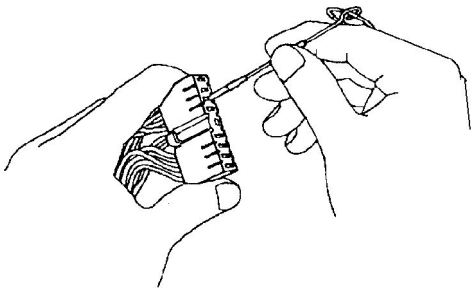

## SYMPTOM TROUBLESHOOTING

- Verify the symptoms, and perform troubleshooting according to the appropriate number.

### Vehicle with ABS

No.	Symptom
1	Neither ABS warning light nor BRAKE system warning light illuminate when the ignition switch is turned to the ON position.
2	ABS warning light does not illuminate when the ignition switch is turned to the ON position.
3	BRAKE system warning light does not illuminate when the ignition switch is turned to the ON position.
4	Both ABS warning light and BRAKE system warning light stay on <b>4 s or more</b> when the ignition switch is turned to the ON position.
5	ABS warning light stays on <b>4 s or more</b> when the ignition switch is turned to the ON position.
6	BRAKE system warning light stays on <b>4 s or more</b> when the ignition switch is turned to the ON position. (Parking brake is released.)

### Vehicle with DSC

No.	Symptom
7	Any of the following lights do not illuminate when the ignition switch is turned to the ON position. <ul style="list-style-type: none"> <li>• ABS warning light</li> <li>• BRAKE system warning light</li> <li>• DSC indicator light</li> <li>• DSC OFF light</li> </ul>
8	Any of the following lights remain on: <ul style="list-style-type: none"> <li>• ABS warning light.</li> <li>• BRAKE system warning light</li> <li>• DSC indicator light</li> <li>• DSC OFF light</li> </ul>
9	There is a malfunction in the system even though ABS warning light, BRAKE system warning light, DSC indicator light and DSC OFF light do not illuminate.
10	ABS or TCS <sup>*1</sup> operates frequently. TCS does not work correctly.
11	DSC <sup>*2</sup> operates frequently. DSC does not work correctly.

\*1

DSC system contains traction control function; DSC indicator light illuminates and goes out while DSC is operating.

\*2

DSC indicator light illuminates and goes out while DSC is operating.

### Vehicle with ABS

x: Applicable

Possible factor		ABS HU/CM	Instrument cluster	Battery	Brake fluid	Brake fluid level sensor	Parking brake switch	Charging system	ABS HU/CM power supply (terminal Z)	ABS HU/CM GND 1 (terminal AA)	Instrument cluster power supply (terminal 1G)	Instrument cluster GND (terminal 1E)	Tire size, tire air pressure	Conventional brakes	Brake pipe routing
Troubleshooting item															
1	Neither ABS warning light nor BRAKE system warning light illuminates when the ignition switch is turned to the ON position.		X								X	X			
2	ABS warning light does not illuminate when the ignition switch is turned to the ON position.	X	X												
3	BRAKE system warning light does not illuminate when the ignition switch is turned to the ON position.	X	X												
4	Both ABS warning light and BRAKE system warning light stay on 4 s or more when the ignition switch is turned to the ON position.	X	X	X				X	X	X					
5	ABS warning light stays on 4 s or more when the ignition switch is turned to the ON position.	X	X												
6	BRAKE system warning light stays on 4 s or more when the ignition switch is turned to the ON position.	X	X		X	X	X								

Vehicle with DSC

x: Applicable

Possible factor		DSC HU/CM	Instrument cluster	Each sensor installation	Battery	Charging system	Brake fluid	Parking brake	Tire	Tire air pressure	Control module power supply system	Control module ground system	Instrument cluster power supply system	Instrument cluster ground system	Conventional brake
Troubleshooting item															
7	Any of the following lights do not illuminate when the ignition switch is turned to the on position: (ABS warning light, BRAKE system warning light, DSC indicator light and/or DSC OFF light).	X	X										X	X	
8	Any of the following lights remain on: (ABS warning light, BRAKE system warning light, DSC indicator light and/or DSC OFF light).		X		X	X	X	X			X	X			
9	There is a malfunction in the system even though ABS warning light, DSC indicator light, and DSC OFF light do not illuminate.														X
10	ABS or TCS (*1) operates frequently. /TCS does not work correctly. (*1): DSC system contains traction control function; DSC indicator light goes on and off while DSC is operating.			X					X	X					
11	DSC (*2) operates frequently. /DSC does not work correctly. (*2): DSC indicator light goes on and while DSC is operating.			X					X	X					

## ON-BOARD DIAGNOSIS [ABS]

### On-Board Diagnostic (OBD) Test Description

- The OBD test inspects the integrity and function of the ABS and outputs the results when requested by the specific tests.
- On-board diagnostic test also:
  - Provides a quick inspection of the ABS usually performed at the start of each diagnostic procedure.
  - Provides verification after repairs to ensure that no other faults occurred during service.
- The OBD test is divided into 3 tests:
  - Read/clear diagnostic results, PID monitor and record and active command modes.

#### Read/clear diagnostic results

- This function allows you to read or clear DTCs in the ABS HU/CM memory.

#### PID/Data monitor and record

- This function allows you to access certain data values, input signals, calculated values, and system status information.

#### Active command modes

- This function allows you to control devices through the WDS or equivalent.

### Reading DTCs Procedure

1. Connect WDS or equivalent to the vehicle DLC-2 connector.

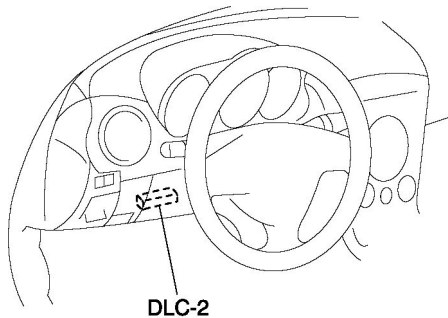

2. Retrieve DTC using WDS or equivalent.

### Clearing DTCs Procedures

1. After repairs have been made, perform the **DTCs reading procedure**.
2. Erase DTC using WDS or equivalent.
3. Ensure that the customer's concern has been resolved.

### PID/Data Monitor and Record Procedure

1. Connect WDS or equivalent to the vehicle DLC-2 connector.

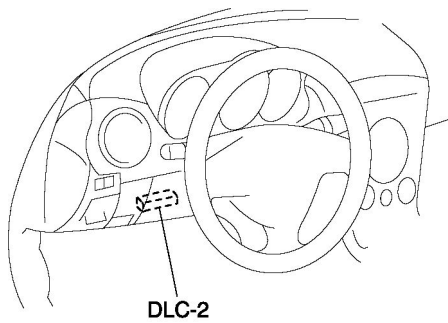

2. Access and monitor PIDs using WDS or equivalent.

### Active Command Modes Procedure

#### NOTE:

- When driving, the ABS motor and each valve automatically turn ABS\_POWER on, and then each command on. ABS\_POWER regulates the power supply for the ABS motor and 8 valves.
1. Connect WDS or equivalent to the vehicle DLC-2 16-pin connector.

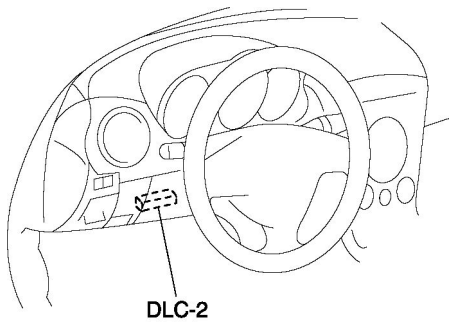

2. Turn the ignition switch to the ON position (engine off) or start the engine.
3. Activate active command modes using WDS or equivalent.

### DTC Table

DTC	System malfunction location	Page
WDS or equivalent		
B1318	Power supply system	(See DTC B1318 [ABS] .)
B1342	ABS HU/CM system	(See DTC B1342 [ABS] .)
C1095	Pump motor, motor relay system	(See DTC C1095, C1096 [ABS] .)
C1096	Pump motor, motor relay system	(See DTC C1095, C1096 [ABS] .)
C1140	ABS HU/CM (pump) system	(See DTC C1140 [ABS] .)
C1145	RF ABS wheel-speed sensor system	(See DTC C1145, C1155, C1165, C1175 [ABS] .)
C1148	RF ABS wheel-speed sensor system	(See DTC C1148, C1158, C1168, C1178, C1234, C1233, C1235, C1236 [ABS] .)
C1155	LF ABS wheel-speed sensor system	(See DTC C1145, C1155, C1165, C1175 [ABS] .)

C1158	LF ABS wheel-speed sensor system	(See DTC C1148, C1158, C1168, C1178, C1234, C1233, C1235, C1236 [ABS] .)
C1165	RR ABS wheel-speed sensor system	(See DTC C1145, C1155, C1165, C1175 [ABS] .)
C1168	RR ABS wheel-speed sensor system	(See DTC C1148, C1158, C1168, C1178, C1234, C1233, C1235, C1236 [ABS] .)
C1175	LR ABS wheel-speed sensor system	(See DTC C1145, C1155, C1165, C1175 [ABS] .)
C1178	LR ABS wheel-speed sensor system	(See DTC C1148, C1158, C1168, C1178, C1234, C1233, C1235, C1236 [ABS] .)
C1186	Fail-safe relay system	(See DTC C1186, C1266 [ABS] .)
C1194	LF outlet solenoid valve system	(See DTC C1210, C1214, C1194, C1198, C1246, C1254, C1242, C1250 [ABS] .)
C1198	LF inlet solenoid valve system	(See DTC C1210, C1214, C1194, C1198, C1246, C1254, C1242, C1250 [ABS] .)
C1210	RF outlet solenoid valve system	(See DTC C1210, C1214, C1194, C1198, C1246, C1254, C1242, C1250 [ABS] .)
C1214	RF inlet solenoid valve system	(See DTC C1210, C1214, C1194, C1198, C1246, C1254, C1242, C1250 [ABS] .)
C1233	LF ABS wheel-speed sensor/ABS sensor rotor system	(See DTC C1148, C1158, C1168, C1178, C1234, C1233, C1235, C1236 [ABS] .)
C1234	RF ABS wheel-speed sensor/ABS sensor rotor system	(See DTC C1148, C1158, C1168, C1178, C1234, C1233, C1235, C1236 [ABS] .)
C1235	RR ABS wheel-speed sensor/ABS sensor rotor system	(See DTC C1148, C1158, C1168, C1178, C1234, C1233, C1235, C1236 [ABS] .)
C1236	LR ABS wheel-speed sensor/ABS sensor rotor system	(See DTC C1148, C1158, C1168, C1178, C1234, C1233, C1235, C1236 [ABS] .)
C1242	LR outlet solenoid valve system	(See DTC C1210, C1214, C1194, C1198, C1246, C1254, C1242, C1250 [ABS] .)
C1246	RR outlet solenoid valve system	(See DTC C1210, C1214, C1194, C1198, C1246, C1254, C1242, C1250 [ABS] .)
C1250	LR inlet solenoid valve system	(See DTC C1210, C1214, C1194, C1198, C1246, C1254, C1242, C1250 [ABS] .)
C1254	RR inlet solenoid valve system	(See DTC C1210, C1214, C1194, C1198, C1246, C1254, C1242, C1250 [ABS] .)
C1266	Fail-safe relay system	(See DTC C1186, C1266 [ABS] .)
C1510	RF solenoid valve, pump motor, or RF ABS wheel-speed sensor/ABS sensor rotor system	(See DTC C1510, C1511, C1512, C1513 [ABS] .)
C1511	LF solenoid valve, pump motor, or LF ABS wheel-speed sensor/ABS sensor rotor system	(See DTC C1510, C1511, C1512, C1513 [ABS] .)
C1512	RR solenoid valve, pump motor, or RR ABS wheel-speed sensor/ABS sensor rotor system	(See DTC C1510, C1511, C1512, C1513 [ABS] .)
C1513	LR solenoid valve, pump motor, or LR ABS wheel-speed sensor/ABS sensor rotor system	(See DTC C1510, C1511, C1512, C1513 [ABS] .)
U1900	CAN communication system	(See MULTIPLEX COMMUNICATION SYSTEM .)
U2516	CAN communication system	(See MULTIPLEX COMMUNICATION SYSTEM .)

## PID/DATA Monitor Table

PID name (definition)	Unit/Condition	Operation condition (reference)	Action	ABS HU/CM terminal
ABS_LAMP (ABS warning light driver output state)	On/Off	<ul style="list-style-type: none"> <li>ABS warning light illuminated: On</li> <li>ABS warning light not illuminated: Off</li> </ul>	Inspect the ABS warning light.	—
ABS_VOLT (System battery voltage value)	V	<ul style="list-style-type: none"> <li>Ignition switch at ON: <b>Approx. 12.2 V</b></li> <li>Idling: <b>Approx. 14.1 V</b></li> </ul>	Inspect the power supply circuit.	Z
ABSLF_I (Left front ABS pressure retention solenoid valve output state)	On/Off	<ul style="list-style-type: none"> <li>Solenoid valve activated: On</li> <li>Solenoid valve not activated: Off</li> </ul>	Inspect the ABS HU/CM.	—
ABSLF_O (Left front ABS pressure reduction solenoid valve output state)	On/Off	<ul style="list-style-type: none"> <li>Solenoid valve activated: On</li> <li>Solenoid valve not activated: Off</li> </ul>	Inspect the ABS HU/CM.	—
ABSLR_I (Left rear ABS pressure retention solenoid valve output state)	On/Off	<ul style="list-style-type: none"> <li>Solenoid valve activated: On</li> <li>Solenoid valve not activated: Off</li> </ul>	Inspect the ABS HU/CM.	—
ABSLR_O (Left rear ABS pressure reduction solenoid valve output state)	On/Off	<ul style="list-style-type: none"> <li>Solenoid valve activated: On</li> <li>Solenoid valve not activated: Off</li> </ul>	Inspect the ABS HU/CM.	—
ABSPMPRLY (Motor relay output state)	On/Off	<ul style="list-style-type: none"> <li>Relay activated: On</li> </ul>	Inspect the ABS HU/CM.	—



		<ul style="list-style-type: none"> <li>Relay not activated: Off</li> </ul>		
<b>ABSRF_I</b> (Right front ABS pressure retention solenoid valve output state)	On/Off	<ul style="list-style-type: none"> <li>Solenoid valve activated: On</li> <li>Solenoid valve not activated: Off</li> </ul>	Inspect the ABS HU/CM.	—
<b>ABSRF_O</b> (Right front ABS pressure reduction solenoid valve output state)	On/Off	<ul style="list-style-type: none"> <li>Solenoid valve activated: On</li> <li>Solenoid valve not activated: Off</li> </ul>	Inspect the ABS HU/CM.	—
<b>ABSRR_I</b> (Right rear ABS pressure retention solenoid valve output state)	On/Off	<ul style="list-style-type: none"> <li>Solenoid valve activated: On</li> <li>Solenoid valve not activated: Off</li> </ul>	Inspect the ABS HU/CM.	—
<b>ABSRR_O</b> (Right rear ABS pressure reduction solenoid valve output state)	On/Off	<ul style="list-style-type: none"> <li>Solenoid valve activated: On</li> <li>Solenoid valve not activated: Off</li> </ul>	Inspect the ABS HU/CM.	—
<b>ABSVLVRLY</b> (Fail-safe relay output state)	On/Off	<ul style="list-style-type: none"> <li>Solenoid valve activated: On</li> <li>Fail-safe relay not activated: Off</li> </ul>	Inspect the ABS HU/CM.	—
<b>BOO_ABS</b> (Brake pedal switch input)	On/Off	<ul style="list-style-type: none"> <li>Brake pedal depressed: On</li> <li>Brake pedal released: Off</li> </ul>	Inspect the brake switch.	Y
<b>BRAKE_LMP</b> (BRAKE system warning light output state)	On/Off	<ul style="list-style-type: none"> <li>Brake system warning light illuminated: On</li> </ul>	Inspect the brake system warning light.	—

		<ul style="list-style-type: none"> <li>Brake system warning light not illuminated: Off</li> </ul>		
CCNTABS (Number of continuous codes)	—	<ul style="list-style-type: none"> <li>DTCs detected: <b>1—255</b></li> <li>No DTCs detected: <b>0</b></li> </ul>	Perform the DTC inspection.	—
LF_WSPD (Left front ABS wheel-speed sensor input)	KPH, MPH	<ul style="list-style-type: none"> <li>Vehicle stopped: <b>0 KPH, 0 MPH</b></li> <li>Vehicle running: Vehicle speed</li> </ul>	Inspect the ABS wheel-speed sensor.	E, I
LR_WSPD (Left rear ABS wheel-speed sensor input)	KPH, MPH	<ul style="list-style-type: none"> <li>Vehicle stopped: <b>0 KPH, 0 MPH</b></li> <li>Vehicle running: Vehicle speed</li> </ul>	Inspect the ABS wheel-speed sensor.	C, F
PMPSTAT (Pump motor output state)	On/Off	<ul style="list-style-type: none"> <li>Pump motor activated: On</li> <li>Pump motor not activated: Off</li> </ul>	Inspect the ABS HU/CM.	—
RF_WSPD (Right front ABS wheel-speed sensor input)	KPH, MPH	<ul style="list-style-type: none"> <li>Vehicle stopped: <b>0 KPH, 0 MPH</b></li> <li>Vehicle running: Vehicle speed</li> </ul>	Inspect the ABS wheel-speed sensor.	D, G
RR_WSPD (Right rear ABS wheel-speed sensor input)	KPH, MPH	<ul style="list-style-type: none"> <li>Vehicle stopped: <b>0 KPH, 0 MPH</b></li> <li>Vehicle running: Vehicle speed</li> </ul>	Inspect the ABS wheel-speed sensor.	A, B

## Active Command Modes Table

Command name	Output part	Operation	Operating condition
ABS_POWER	Fail-safe relay	On/Off	Ignition switch at ON
LF_INLET	LF inlet solenoid valve		
LF_OUTLET	LF outlet solenoid valve		
LR_INLET	LR inlet solenoid valve		
LR_OUTLET	LR outlet solenoid valve		
PMP_MOTOR	Pump motor		
RF_INLET	RF inlet solenoid valve		
RF_OUTLET	RF outlet solenoid valve		
RR_INLET	RR inlet solenoid valve		
RR_OUTLET	RR outlet solenoid valve		

## DTC B1318 [ABS]

### CAUTION:

- If the battery voltage drops during the inspection, B1318 will be output as a current malfunction and the proper diagnosis cannot be made. Be careful not to let the battery voltage drop.

DTC	B1318	Power supply
<b>DETECTION CONDITION</b>	<ul style="list-style-type: none"> <li>The voltage at ABS HU/CM terminal Z is <b>approx. 10 V or less</b> .</li> </ul>	
<b>POSSIBLE CAUSE</b>	<ul style="list-style-type: none"> <li>ENGINE 15 A fuse malfunction</li> <li>Open circuit or short to ground in the wiring harness between the ABS HU/CM terminal Z and the battery</li> <li>Open circuit or faulty ground in the wiring harness between the ABS HU/CM terminal AC and the body ground</li> <li>Battery deterioration</li> <li>Generator malfunction</li> <li>Poor connection at connectors (female terminal)</li> </ul>	

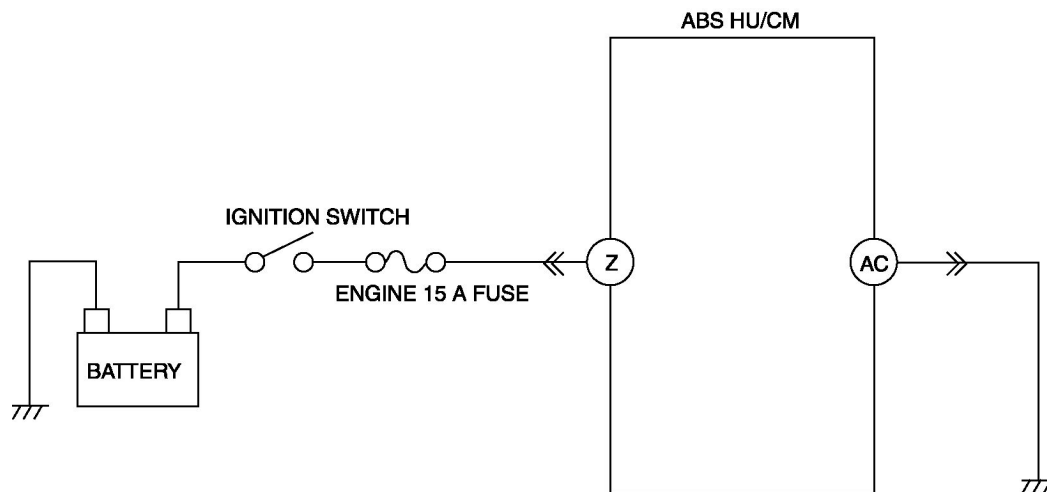

ABS HU/CM WIRING HARNESS-SIDE CONNECTOR

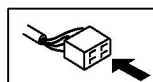
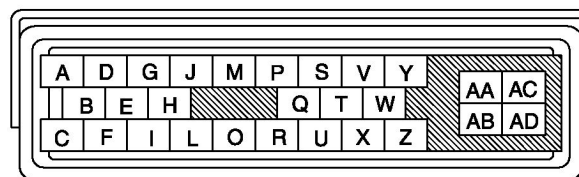

Diagnostic procedure

STEP	INSPECTION	ACTION	
1	<b>INSPECT BATTERY VOLTAGE</b> <ul style="list-style-type: none"> <li>Is the battery terminal voltage normal?</li> </ul>	Yes	Make sure that battery terminal connection is normal. Go to the next step.
		No	Charge or replace the battery, then go to Step 6.
2	<b>INSPECT BATTERY GRAVITY</b> <ul style="list-style-type: none"> <li>Is battery specific gravity as specified?</li> </ul>	Yes	Go to the next step.
		No	Replace the battery, then go to Step 6.
3	<b>INSPECT CHARGING SYSTEM</b> <ul style="list-style-type: none"> <li>Are the generator and drive belt tensions normal?</li> </ul>	Yes	Go to the next step.
		No	Adjust drive belt tension if necessary. Replace generator and/or drive belt as necessary.
4	<b>INSPECT ABS HU/CM POWER SUPPLY FOR OPEN CIRCUIT</b> <ul style="list-style-type: none"> <li>Start the engine.</li> <li>Measure the voltage between ABS HU/CM terminal Z and ground.</li> <li>Is the voltage <b>above 10 V</b> ?</li> </ul>	Yes	Go to the next step.
		No	Repair or replace the wiring harness for open circuit between the ABS HU/CM and ground, then go to Step 6.
5	<b>INSPECT ABS HU/CM GROUND FOR POOR GROUND OR OPEN CIRCUIT</b> <ul style="list-style-type: none"> <li>Turn the ignition switch off.</li> <li>Measure the resistance between ground and ABS HU/CM terminal AC.</li> <li>Is the resistance <b>within 0—1 ohm</b> ?</li> </ul>	Yes	Go to the next step.
		No	If there is no continuity: <ul style="list-style-type: none"> <li>Repair or replace the wiring harness for open circuit between the ABS HU/CM and ground, then go to the next step.</li> </ul> If the resistance is not <b>within 0—1 ohm</b> : <ul style="list-style-type: none"> <li>Repair or replace harness for poor ground, then go to the next step.</li> </ul>
6		Yes	Replace the ABS HU/CM, then go to the next step.

	<p><b>VERIFY TROUBLESHOOTING COMPLETED</b></p> <ul style="list-style-type: none"> <li>• Make sure to reconnect all disconnected connectors.</li> <li>• Clear the DTC from the memory.</li> </ul> <ul style="list-style-type: none"> <li>• Is the same DTC present?</li> </ul>	No	Go to the next step.
7	<p><b>VERIFY AFTER REPAIR PROCEDURE</b></p> <ul style="list-style-type: none"> <li>• Are any other DTCs present?</li> </ul>	Yes	Go to the applicable DTC inspection.
		No	DTC troubleshooting completed.

## DTC B1342 [ABS]

DTC	B1342	ABS HU/CM
<b>DETECTION CONDITION</b>	<ul style="list-style-type: none"> <li>The ABS HU/CM on-board diagnostic function detects control module malfunction.</li> </ul>	
<b>POSSIBLE CAUSE</b>	<ul style="list-style-type: none"> <li>ABS HU/CM internal malfunction</li> </ul>	

### Diagnostic procedure

STEP	INSPECTION	ACTION	
1	<b>VERIFY CURRENT STATUS OF MALFUNCTION</b> <ul style="list-style-type: none"> <li>Clear the DTC from the memory.</li> <li>Start the engine and drive the vehicle at <b>10 km/h {6.2 mph} or more</b> .</li> <li>Is same DTC present?</li> </ul>	Yes	Replace the ABS HU/CM, then go to the next step.
		No	Go to the next step.
2	<b>VERIFY AFTER REPAIR PROCEDURE</b> <ul style="list-style-type: none"> <li>Are any other DTCs present?</li> </ul>	Yes	Go to the applicable DTC inspection.
		No	DTC troubleshooting completed.

## DTC C1510, C1511, C1512, C1513 [ABS]

<b>DTC</b>	<b>C1510</b>	<b>RF solenoid valve, pump motor or RF ABS wheel-speed sensor/ABS sensor rotor.</b>
	<b>C1511</b>	<b>LF solenoid valve, pump motor or LF ABS wheel-speed sensor/ABS sensor rotor.</b>
	<b>C1512</b>	<b>RR solenoid valve, pump motor or RR ABS wheel-speed sensor/ABS sensor rotor.</b>
	<b>C1513</b>	<b>LR solenoid valve, pump motor or LR ABS wheel-speed sensor/ABS sensor rotor.</b>
<b>DETECTION CONDITION</b>	<ul style="list-style-type: none"> <li>• Wheel lock-up continues during ABS operation (pressure reduction inoperative) for <b>4 s or more</b> .</li> <li>• Pressure reduction on a single wheel continues for <b>20 s or more</b> .</li> </ul>	
<b>POSSIBLE CAUSE</b>	<ul style="list-style-type: none"> <li>• Malfunction of ABS wheel-speed sensor and/or sensor rotor (abnormal output of vehicle wheel speed signal)</li> <li>• Malfunction of ABS HU/CM internal solenoid valves</li> <li>• Malfunction of ABS HU/CM internal pump motor</li> </ul>	

### Diagnostic procedure

STEP	INSPECTION	ACTION	
1	<b>INSPECT ABS WHEEL-SPEED SENSOR FOR MALFUNCTION</b> <ul style="list-style-type: none"> <li>• Turn the ignition switch off.</li> <li>• Connect the WDS or equivalent to the DLC-2.</li> <li>• Perform the DTC inspection.</li> <li>• Are any of the ABS wheel-speed sensor related DTCs output at the same time?</li> </ul>	Yes	Go to the applicable DTC inspection.
		No	Go to the next step.
2	<b>INSPECT FOR SOLENOID VALVE MALFUNCTION</b> <ul style="list-style-type: none"> <li>• Perform the DTC inspection.</li> <li>• Are any of the solenoid valve related DTCs output at the same time?</li> </ul>	Yes	Go to the applicable DTC inspection.
		No	Go to the next step.
3	<b>INSPECT PUMP MOTOR AND MOTOR RELAY FOR MALFUNCTION</b>	Yes	Go to the applicable DTC inspection.



**DTC C1210, C1214, C1194, C1198, C1246, C1254, C1242, C1250 [ABS]**

<b>DTC</b>	<p><b>C 1210</b></p> <p><b>C 1214</b></p> <p><b>C 1194</b></p> <p><b>C 1198</b></p> <p><b>C 1246</b></p> <p><b>C 1254</b></p> <p><b>C 1242</b></p> <p><b>C 1250</b></p>	<p><b>RF outlet solenoid valve</b></p> <p><b>RF inlet solenoid valve</b></p> <p><b>LF outlet solenoid valve</b></p> <p><b>LF inlet solenoid valve</b></p> <p><b>RR outlet solenoid valve</b></p> <p><b>RR inlet solenoid valve</b></p> <p><b>LR outlet solenoid valve</b></p> <p><b>LR inlet solenoid valve</b></p>
<b>DETECTION CONDITION</b>	<ul style="list-style-type: none"> <li>• Solenoid valve operation does not correspond to solenoid ON/OFF commands from the ABS HU/CM.</li> </ul>	
<b>POSSIBLE CAUSE</b>	<ul style="list-style-type: none"> <li>• Open or short circuit in the ABS HU/CM internal solenoid valves</li> <li>• Solenoid valve malfunction</li> <li>• Poor connection at connectors (female terminal)</li> </ul>	

# DTC C1186, C1266 [ABS]

DTC	C1186, C1266	Fail-safe relay
<p><b>DETECTION CONDITION</b></p>	<ul style="list-style-type: none"> <li>• C1186               <ul style="list-style-type: none"> <li>▪ ABS HU/CM internal fail-safe relay remains OFF (stuck) when fail-safe relay ON is commanded.</li> </ul> </li> <li>• C1266               <ul style="list-style-type: none"> <li>▪ ABS HU/CM internal fail-safe relay remains ON (stuck) when fail-safe relay OFF is commanded.</li> </ul> </li> </ul>	
<p><b>POSSIBLE CAUSE</b></p>	<ul style="list-style-type: none"> <li>• ABS/DSC 60 A fuse malfunction</li> <li>• Open circuit or short to ground in the wiring harness between the battery and the ABS HU/CM terminal AA</li> <li>• Open or short circuit in the ABS HU/CM internal fail-safe relay, or stuck fail-safe relay</li> <li>• Poor connection at connectors (female terminal)</li> </ul>	

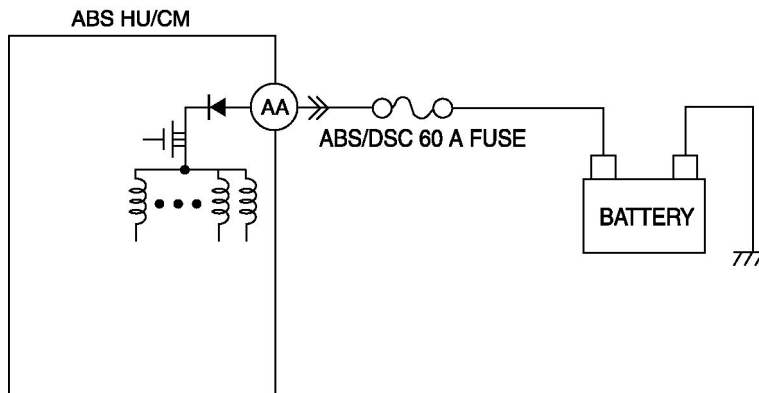

ABS HU/CM WIRING HARNESS-SIDE CONNECTOR

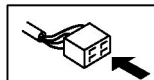
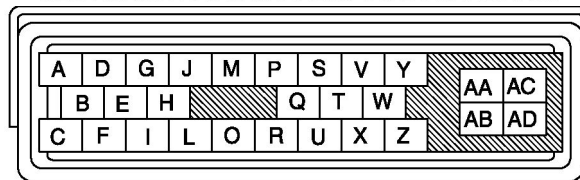

# DTC C1145, C1155, C1165, C1175 [ABS]

<p><b>DTC</b></p>	<p><b>C1145</b> <b>C1155</b> <b>C1165</b> <b>C1175</b></p>	<p><b>RF ABS wheel-speed sensor</b> <b>LF ABS wheel-speed sensor</b> <b>RR ABS wheel-speed sensor</b> <b>LR ABS wheel-speed sensor</b></p>
<p><b>DETECTION CONDITION</b></p>	<ul style="list-style-type: none"> <li>Open circuit or short to ground has been detected in the ABS wheel-speed sensor wiring harness on any of the four vehicle wheels.</li> </ul>	
<p><b>POSSIBLE CAUSE</b></p>	<ul style="list-style-type: none"> <li>Open circuit or short to ground in the wiring harness between the following ABS HU/CM terminal and the ABS wheel-speed sensor terminal: <ul style="list-style-type: none"> <li>ABS HU/CM terminal G—RF ABS wheel-speed sensor terminal A</li> <li>ABS HU/CM terminal D—RF ABS wheel-speed sensor terminal B</li> <li>ABS HU/CM terminal I—LF ABS wheel-speed sensor terminal A</li> <li>ABS HU/CM terminal E—LF ABS wheel-speed sensor terminal B</li> <li>ABS HU/CM terminal A—RR ABS wheel-speed sensor terminal A</li> <li>ABS HU/CM terminal B—RR ABS wheel-speed sensor terminal B</li> <li>ABS HU/CM terminal C—LR ABS wheel-speed sensor terminal A</li> <li>ABS HU/CM terminal F—LR ABS wheel-speed sensor terminal B</li> </ul> </li> <li>ABS wheel-speed sensor malfunction</li> <li>Poor connection at connectors (female terminal)</li> </ul>	
<p>The diagram illustrates the electrical connections between the ABS HU/CM and four wheel speed sensors. Each sensor has two terminals, A and B. The connections are as follows:</p> <ul style="list-style-type: none"> <li><b>RF ABS WHEEL-SPEED SENSOR:</b> Terminal A connects to HU/CM terminal G; Terminal B connects to HU/CM terminal D.</li> <li><b>LF ABS WHEEL-SPEED SENSOR:</b> Terminal A connects to HU/CM terminal I; Terminal B connects to HU/CM terminal E.</li> <li><b>RR ABS WHEEL-SPEED SENSOR:</b> Terminal A connects to HU/CM terminal A; Terminal B connects to HU/CM terminal B.</li> <li><b>LR ABS WHEEL-SPEED SENSOR:</b> Terminal A connects to HU/CM terminal C; Terminal B connects to HU/CM terminal F.</li> </ul> <p>Each sensor terminal is shown with a ground connection. Below the diagram are two connector pin layouts:</p> <ul style="list-style-type: none"> <li><b>ABS HU/CM WIRING HARNESS-SIDE CONNECTOR:</b> A 24-pin connector with terminals labeled A, D, G, J, M, P, S, V, Y, AA, AC, AB, AD, B, E, H, Q, T, W, C, F, I, L, O, R, U, X, Z.</li> <li><b>ABS WHEEL-SPEED SENSOR WIRING HARNESS-SIDE CONNECTOR:</b> Two 2-pin connectors labeled FRONT and REAR, each with terminals B and A.</li> </ul> <p>A note at the bottom indicates that the connector should be inserted with the arrow pointing towards the sensor.</p>		

## DTC C1140 [ABS]

<b>DTC</b>	<b>C1140</b>	<b>ABS HU/CM (pump)</b>
<b>DETECTION CONDITION</b>	<ul style="list-style-type: none"> <li>Lock-up of right front and left rear wheels, or left front and right rear wheel is detected during ABS operation.</li> </ul>	
<b>POSSIBLE CAUSE</b>	<ul style="list-style-type: none"> <li>ABS HU/CM internal pump motor frozen</li> </ul>	

### Diagnostic procedure

STEP	INSPECTION	ACTION	
1	<b>INSPECT IF MALFUNCTION OCCURRED DUE TO ABS HU/CM INTERNAL MALFUNCTION (PIPE CLOGGING)</b> <ul style="list-style-type: none"> <li>Perform the ABS system inspection.</li> <li>Is the system normal?</li> </ul>	Yes	Go to the next step.
		No	Replace the ABS HU/CM, then go to Step 4.
2	<b>INSPECT IF MALFUNCTION OCCURRED IN CONVENTIONAL BRAKE SYSTEM</b> <ul style="list-style-type: none"> <li>Inspect the brake fluid level.</li> <li>Start the engine.</li> <li>Drive the vehicle and inspect the brake operation.</li> <li>Is the result normal?</li> </ul>	Yes	Go to the next step.
		No	Inspect the conventional brake lines. Repair the malfunctioning part, then go to Step 4.
3	<b>INSPECT IF MALFUNCTION IS DUE TO PARKING BRAKE DRAGGING</b> <ul style="list-style-type: none"> <li>Turn the ignition switch off.</li> <li>Jack up the vehicle and support it with safety stand.</li> <li>Release the parking brake.</li> <li>Does the rear wheel drag when turned by hand?</li> </ul>	Yes	Go to the next step.
		No	Repair the parking brake, then go to the next step.
4	<b>VERIFY DTC TROUBLESHOOTING COMPLETED</b> <ul style="list-style-type: none"> <li>Clear the DTC from the memory.</li> <li>Start the engine and drive the vehicle at <b>10 km/h {6.2 mph} or more</b> .</li> </ul>	Yes	Repeat the inspection from Step 1. If the malfunction recurs, replace the ABS HU/CM.

## DTC C1095, C1096 [ABS]

DTC	C1095, C1096	Pump motor, motor relay
<b>DETECTION CONDITION</b>	<ul style="list-style-type: none"> <li>• C1095               <ul style="list-style-type: none"> <li>▪ ABS motor monitor signal does not correspond to ABS HU/CM OFF signal.</li> </ul> </li> <li>• C1096               <ul style="list-style-type: none"> <li>▪ ABS motor monitor signal does not correspond to ABS HU/CM ON signal.</li> <li>▪ ABS motor monitor OFF signal is input within specified time limit when the motor signal is switched from ON to OFF by ABS HU/CM.</li> </ul> </li> </ul>	
<b>POSSIBLE CAUSE</b>	<ul style="list-style-type: none"> <li>• ABS/DSC 60 A fuse malfunction</li> <li>• Open or short to ground circuit in the wiring harness between the battery and the ABS HU/CM terminal AB</li> <li>• Open circuit in the wiring harness between the ABS HU/CM terminal AD and the body ground</li> <li>• Open or short circuit in the ABS HU/CM internal motor relay, or stuck motor relay</li> <li>• Open or short circuit in the ABS HU/CM internal motor, or frozen motor</li> <li>• Fail-safe relay malfunction</li> <li>• Poor connection at connectors (female terminal)</li> </ul>	

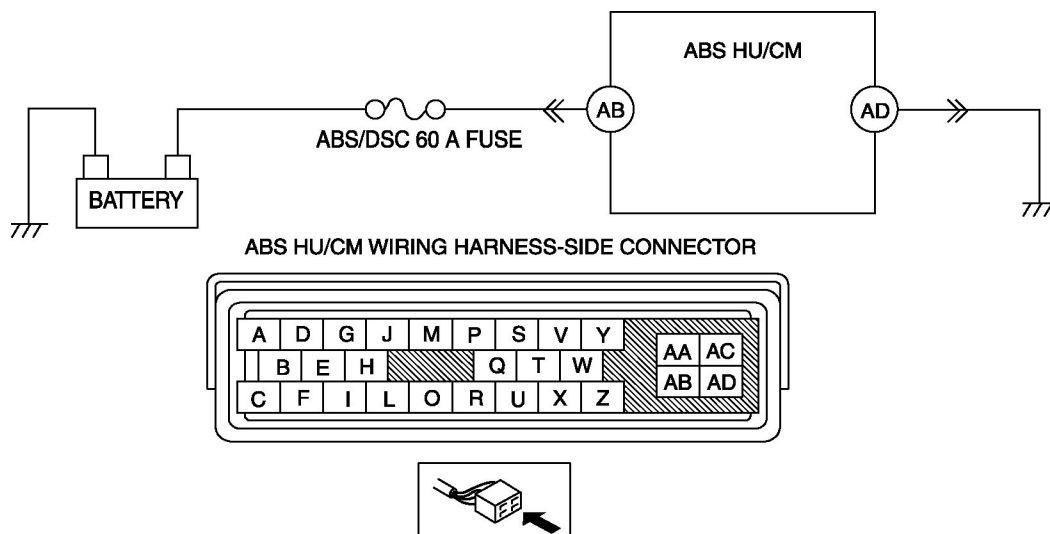

Notes:

## ON-BOARD DIAGNOSIS [DYNAMIC STABILITY CONTROL]

### On-Board Diagnostic (OBD) Test Description

- The OBD test inspects the integrity and function of the DSC and outputs the results when requested by the specific tests.
- On-board diagnostic test also:
  - Provides a quick inspection of the DSC usually performed at the start of each diagnostic procedure.
  - Provides verification after repairs to ensure that no other faults occurred during service.
- The OBD test is divided into 3 tests:
  - Read/clear diagnostic results, PID monitor and record and active command modes.

#### Read/clear diagnostic results

- This function allows you to read or clear DTCs in the DSC HU/CM memory.

#### PID/Data monitor and record

- This function allows you to access certain data values, input signals, calculated values, and system status information.

#### Active command modes

- This function allows you to control devices through the WDS or equivalent.

### Reading DTCs Procedure

1. Connect WDS or equivalent to the vehicle DLC-2 connector.

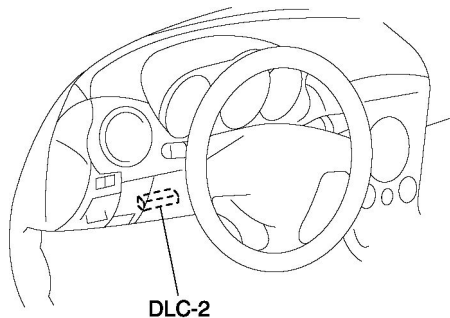

2. Retrieve DTC using WDS or equivalent.

### Clearing DTCs Procedures

1. After repairs have been made, perform the **DTCs reading procedure**.
2. Erase DTC using WDS or equivalent.
3. Ensure that the customer's concern has been resolved.

### PID/Data Monitor and Record Procedure

1. Connect WDS or equivalent to the vehicle DLC-2 connector.

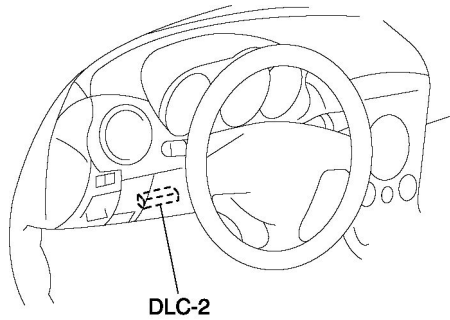

2. Access and monitor PIDs using WDS or equivalent.

### Active Command Modes Procedure

1. Connect WDS or equivalent to the vehicle DLC-2 16-pin connector.

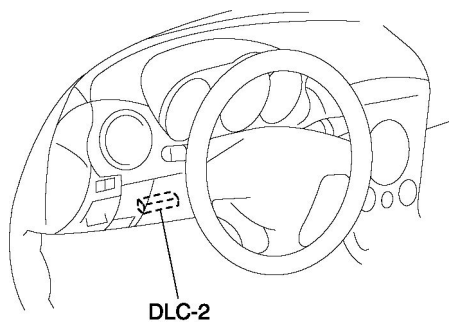

2. Turn the ignition switch to the ON position (engine off) or start the engine.
3. Activate active command modes using WDS or equivalent.

### DTC Table

DTC	System malfunction location	Page
WDS or equivalent		
B1318	Power supply system	(See DTC B1318 [DYNAMIC STABILITY CONTROL] .)
B1342	DSC HU/CM system	(See DTC B1342 [DYNAMIC STABILITY CONTROL] .)
B1484	Brake switch system	(See DTC B1484, C1953 [DYNAMIC STABILITY CONTROL] .)
B2477	DSC HU/CM configuration system	(See DTC B2477 [DYNAMIC STABILITY CONTROL] .)
C1093	DSC OFF switch system	(See DTC C1093 [DYNAMIC STABILITY CONTROL] .)
C1095	Pump motor, motor relay system	(See DTC C1095, C1096 [DYNAMIC STABILITY CONTROL] .)
C1096	Pump motor, motor relay system	(See DTC C1095, C1096 [DYNAMIC STABILITY CONTROL] .)
C1119	PCM, TCM communication system	(See DTC C1119, C1134 [DYNAMIC STABILITY CONTROL] .)
C1134	PCM, TCM communication system	(See DTC C1119, C1134 [DYNAMIC STABILITY CONTROL] .)
C1145	RF ABS wheel-speed sensor (open circuit) system	(See DTC C1145, C1155, C1165, C1175 [DYNAMIC STABILITY CONTROL] .)
C1148	RF ABS wheel-speed sensor/ABS sensor rotor system	(See DTC C1148, C1158, C1168, C1178 [DYNAMIC STABILITY CONTROL] .)



C1155	LF ABS wheel-speed sensor (open circuit) system	(See DTC C1145, C1155, C1165, C1175 [DYNAMIC STABILITY CONTROL] .)
C1158	LF ABS wheel-speed sensor/ABS sensor rotor system	(See DTC C1148, C1158, C1168, C1178 [DYNAMIC STABILITY CONTROL] .)
C1165	RR ABS wheel-speed sensor (open circuit) system	(See DTC C1145, C1155, C1165, C1175 [DYNAMIC STABILITY CONTROL] .)
C1168	RR ABS wheel-speed sensor/ABS sensor rotor system	(See DTC C1148, C1158, C1168, C1178 [DYNAMIC STABILITY CONTROL] .)
C1175	LR ABS wheel-speed sensor (open circuit) system	(See DTC C1145, C1155, C1165, C1175 [DYNAMIC STABILITY CONTROL] .)
C1178	LR ABS wheel-speed sensor/ABS sensor rotor system	(See DTC C1148, C1158, C1168, C1178 [DYNAMIC STABILITY CONTROL] .)
C1186	Valve relay system	(See DTC C1186, C1266 [DYNAMIC STABILITY CONTROL] .)
C1194	LF outlet solenoid valve system	(See DTC C1194, C1198, C1210, C1214, C1242, C1246, C1250, C1254, C1400, C1410, C1957, C1958 [DYNAMIC STABILITY CONTROL] .)
C1198	LF inlet solenoid valve system	(See DTC C1194, C1198, C1210, C1214, C1242, C1246, C1250, C1254, C1400, C1410, C1957, C1958 [DYNAMIC STABILITY CONTROL] .)
C1210	RF outlet solenoid valve system	(See DTC C1194, C1198, C1210, C1214, C1242, C1246, C1250, C1254, C1400, C1410, C1957, C1958 [DYNAMIC STABILITY CONTROL] .)
C1214	RF inlet solenoid valve system	(See DTC C1194, C1198, C1210, C1214, C1242, C1246, C1250, C1254, C1400, C1410, C1957, C1958 [DYNAMIC STABILITY CONTROL] .)
C1222	ABS wheel-speed sensor (slip monitor) system	(See DTC C1222 [DYNAMIC STABILITY CONTROL] .)
C1233	LF ABS wheel-speed sensor (short to ground) system	(See DTC C1233, C1234, C1235, C1236 [DYNAMIC STABILITY CONTROL] .)
C1234	RF ABS wheel-speed sensor (short to ground) system	(See DTC C1233, C1234, C1235, C1236 [DYNAMIC STABILITY CONTROL] .)
C1235	RR ABS wheel-speed sensor (short to ground) system	(See DTC C1233, C1234, C1235, C1236 [DYNAMIC STABILITY CONTROL] .)
C1236	LR ABS wheel-speed sensor (short to ground) system	(See DTC C1233, C1234, C1235, C1236 [DYNAMIC STABILITY CONTROL] .)
C1242	LR outlet solenoid valve system	(See DTC C1194, C1198, C1210, C1214, C1242, C1246, C1250, C1254, C1400, C1410, C1957, C1958 [DYNAMIC STABILITY CONTROL] .)
C1246	RR outlet solenoid valve system	(See DTC C1194, C1198, C1210, C1214, C1242, C1246, C1250, C1254, C1400, C1410, C1957, C1958 [DYNAMIC STABILITY CONTROL] .)
C1250	LR inlet solenoid valve system	(See DTC C1194, C1198, C1210, C1214, C1242, C1246, C1250, C1254, C1400, C1410, C1957, C1958 [DYNAMIC STABILITY CONTROL] .)
C1254	RR inlet solenoid valve system	(See DTC C1194, C1198, C1210, C1214, C1242, C1246, C1250, C1254, C1400, C1410, C1957, C1958 [DYNAMIC STABILITY CONTROL] .)
C1266	Valve relay system	(See DTC C1186, C1266 [DYNAMIC STABILITY CONTROL] .)
C1279	Combined sensor system	(See DTC C1279, C1280, C1281, C1282, C1951, C1952, C1959, C2768 [DYNAMIC STABILITY CONTROL] .)
C1280	Combined sensor system	(See DTC C1279, C1280, C1281, C1282, C1951, C1952, C1959, C2768 [DYNAMIC STABILITY CONTROL] .)
C1281	Combined sensor system	(See DTC C1279, C1280, C1281, C1282, C1951, C1952, C1959, C2768 [DYNAMIC STABILITY CONTROL] .)
C1282	Combined sensor system	(See DTC C1279, C1280, C1281, C1282, C1951, C1952, C1959, C2768 [DYNAMIC STABILITY CONTROL] .)
C1288	Brake fluid pressure sensor system	(See DTC C1288, C1290, C1440, C1730, C1954 [DYNAMIC STABILITY

		CONTROL] .)
C1290	Brake fluid pressure sensor system	(See DTC C1288, C1290, C1440, C1730, C1954 [DYNAMIC STABILITY CONTROL] .)
C1295	Steering angle sensor system	(See DTC C1295, C1307, C1937, C1938, C1956 [DYNAMIC STABILITY CONTROL] .)
C1306	Steering angle sensor (abnormal initialization) system	(See DTC C1306 [DYNAMIC STABILITY CONTROL] .)
C1307	Steering angle sensor system	(See DTC C1295, C1307, C1937, C1938, C1956 [DYNAMIC STABILITY CONTROL] .)
C1400	RF traction switch solenoid valve system	(See DTC C1194, C1198, C1210, C1214, C1242, C1246, C1250, C1254, C1400, C1410, C1957, C1958 [DYNAMIC STABILITY CONTROL] .)
C1410	LF traction switch solenoid valve system	(See DTC C1194, C1198, C1210, C1214, C1242, C1246, C1250, C1254, C1400, C1410, C1957, C1958 [DYNAMIC STABILITY CONTROL] .)
C1440	Brake fluid pressure sensor system	(See DTC C1288, C1290, C1440, C1730, C1954 [DYNAMIC STABILITY CONTROL] .)
C1730	Brake fluid pressure sensor system	(See DTC C1288, C1290, C1440, C1730, C1954 [DYNAMIC STABILITY CONTROL] .)
C1805	Incorrect DSC HU/CM installed	(See DTC C1805 [DYNAMIC STABILITY CONTROL] .)
C1937	Steering angle sensor system	(See DTC C1295, C1307, C1937, C1938, C1956 [DYNAMIC STABILITY CONTROL] .)
C1938	Steering angle sensor system	(See DTC C1295, C1307, C1937, C1938, C1956 [DYNAMIC STABILITY CONTROL] .)
C1951	Combined sensor system	(See DTC C1279, C1280, C1281, C1282, C1951, C1952, C1959, C2768 [DYNAMIC STABILITY CONTROL] .)
C1952	Combined sensor system	(See DTC C1279, C1280, C1281, C1282, C1951, C1952, C1959, C2768 [DYNAMIC STABILITY CONTROL] .)
C1953	Brake switch system	(See DTC B1484, C1953 [DYNAMIC STABILITY CONTROL] .)
C1954	Brake fluid pressure sensor system	(See DTC C1288, C1290, C1440, C1730, C1954 [DYNAMIC STABILITY CONTROL] .)
C1956	Steering angle sensor system	(See DTC C1295, C1307, C1937, C1938, C1956 [DYNAMIC STABILITY CONTROL] .)
C1957	RF DSC switch solenoid valve system	(See DTC C1194, C1198, C1210, C1214, C1242, C1246, C1250, C1254, C1400, C1410, C1957, C1958 [DYNAMIC STABILITY CONTROL] .)
C1958	LF DSC switch solenoid valve system	(See DTC C1194, C1198, C1210, C1214, C1242, C1246, C1250, C1254, C1400, C1410, C1957, C1958 [DYNAMIC STABILITY CONTROL] .)
C1959	Combined sensor system	(See DTC C1279, C1280, C1281, C1282, C1951, C1952, C1959, C2768 [DYNAMIC STABILITY CONTROL] .)
C1994	DSC control system	(See DTC C1994 [DYNAMIC STABILITY CONTROL] .)
C2768	Combined sensor system	(See DTC C1279, C1280, C1281, C1282, C1951, C1952, C1959, C2768 [DYNAMIC STABILITY CONTROL] .)
C2778	Steering angle sensor (abnormal battery voltage) system	(See DTC C2778 [DYNAMIC STABILITY CONTROL] .)
U1900	CAN communication system	(See MULTIPLEX COMMUNICATION SYSTEM .)
U2516	CAN communication system	(See MULTIPLEX COMMUNICATION SYSTEM .)

## PID/DATA Monitor Table

PID name (definition)	Unit/Condition	Operation condition (reference)	Action	DSC HU/CM terminal
ABS_LAMP (ABS warning light driver output state)	On/Off	<ul style="list-style-type: none"> <li>ABS warning light illuminated: On</li> <li>ABS warning light not illuminated: Off</li> </ul>	Inspect the ABS warning light.	—
ABS_VOLT (System battery voltage value)	V	<ul style="list-style-type: none"> <li>Ignition switch at ON: <b>Approx. 12.2 V</b></li> <li>Idling: <b>Approx. 14.1 V</b></li> </ul>	Inspect power supply circuit.	K
ABSLF_I (Left front ABS pressure retention solenoid valve output state)	On/Off	<ul style="list-style-type: none"> <li>Solenoid valve activated: On</li> <li>Solenoid valve not activated: Off</li> </ul>	Inspect the DSC HU/CM.	—
ABSLF_O (Left front ABS pressure reduction solenoid valve output state)	On/Off	<ul style="list-style-type: none"> <li>Solenoid valve activated: On</li> <li>Solenoid valve not activated: Off</li> </ul>	Inspect the DSC HU/CM.	—
ABSLR_I (Left rear ABS pressure retention solenoid valve output state)	On/Off	<ul style="list-style-type: none"> <li>Solenoid valve activated: On</li> <li>Solenoid valve not activated: Off</li> </ul>	Inspect the DSC HU/CM.	—
ABSLR_O (Left rear ABS pressure reduction solenoid valve output state)	On/Off	<ul style="list-style-type: none"> <li>Solenoid valve activated: On</li> <li>Solenoid valve not activated: Off</li> </ul>	Inspect the DSC HU/CM.	—
ABSRF_I (Right front ABS pressure	On/Off	<ul style="list-style-type: none"> <li>Solenoid valve activated:</li> </ul>	Inspect the DSC HU/CM.	—

retention solenoid valve output state)		<ul style="list-style-type: none"> <li>On</li> <li>Solenoid valve not activated: Off</li> </ul>		
<b>ABSRF_O</b> (Right front ABS pressure reduction solenoid valve output state)	On/Off	<ul style="list-style-type: none"> <li>Solenoid valve activated: On</li> <li>Solenoid valve not activated: Off</li> </ul>	Inspect the DSC HU/CM.	—
<b>ABSRR_I</b> (Right rear ABS pressure retention solenoid valve output state)	On/Off	<ul style="list-style-type: none"> <li>Solenoid valve activated: On</li> <li>Solenoid valve not activated: Off</li> </ul>	Inspect the DSC HU/CM.	—
<b>ABSRR_O</b> (Right rear ABS pressure reduction solenoid valve output state)	On/Off	<ul style="list-style-type: none"> <li>Solenoid valve activated: On</li> <li>Solenoid valve not activated: Off</li> </ul>	Inspect the DSC HU/CM.	—
<b>BOO_ABS</b> (Brake pedal switch input)	On/Off	<ul style="list-style-type: none"> <li>Brake pedal depressed: On</li> <li>Brake pedal released: Off</li> </ul>	Inspect the brake switch.	AD
<b>BRAKE_LMP</b> (BRAKE system warning light output state)	On/Off	<ul style="list-style-type: none"> <li>Brake system warning light illuminated: On</li> <li>Brake system warning light not illuminated: Off</li> </ul>	Inspect the brake system warning light.	—
<b>CCNTABS</b> (Number of continuous codes)	—	<ul style="list-style-type: none"> <li>DTCs detected: <b>1—255</b></li> <li>No DTCs detected: <b>0</b></li> </ul>	Perform the DTC inspection.	—
<b>L_DSC O</b>	On/Off	<ul style="list-style-type: none"> <li>Solenoid valve activated: On</li> <li>Solenoid valve not</li> </ul>	Inspect the DSC HU/CM.	—

		activated: Off		
LAT ACC	G	<ul style="list-style-type: none"> <li>Vehicle stopped or driving at constant speed: <b>0 G</b></li> <li>Cornering to right: Changes <b>0 G—positive</b></li> <li>Cornering to left: Changes <b>0 G—negative</b></li> </ul>	Inspect the combined sensor.	G
LF_WSPD (Left front ABS wheel-speed sensor input)	KPH, MPH	<ul style="list-style-type: none"> <li>Vehicle stopped: <b>0 KPH, 0 MPH</b></li> <li>Vehicle running: vehicle speed</li> </ul>	Inspect the ABS wheel-speed sensor.	AJ, AL
LR_WSPD (Left rear ABS wheel-speed sensor input)	KPH, MPH	<ul style="list-style-type: none"> <li>Vehicle stopped: <b>0 KPH, 0 MPH</b></li> <li>Vehicle running: Vehicle speed</li> </ul>	Inspect the ABS wheel-speed sensor.	AH, AK
MCYLIP	kPa, psi, Bar	<ul style="list-style-type: none"> <li>Brake pedal released: <b>0 kPa, 0 psi, 0 Bar</b></li> <li>Brake pedal depressed: Changes according to the brake fluid pressure</li> </ul>	Inspect the brake fluid pressure sensor.	—
PMPSTAT (Pump motor output state)	On/Off	<ul style="list-style-type: none"> <li>Pump motor activated: On</li> <li>Pump motor not activated: Off</li> </ul>	Inspect the DSC HU/CM.	—
R_DSC O	On/Off	<ul style="list-style-type: none"> <li>Solenoid valve activated: On</li> <li>Solenoid valve not activated: Off</li> </ul>	Inspect the DSC HU/CM.	—
RF_WSPD	KPH, MPH		Inspect the ABS	AC, AE

(Right front ABS wheel-speed sensor input)		<ul style="list-style-type: none"> <li>Vehicle stopped: <b>0 KPH, 0 MPH</b></li> <li>Vehicle running: vehicle speed</li> </ul>	wheel-speed sensor.	
RPM (Engine speed signal input)	RPM	<ul style="list-style-type: none"> <li>Engine stopped: <b>0 RPM</b></li> <li>Engine speed at 3,000 rpm: <b>3,000 RPM</b></li> </ul>	Inspect the PCM. Inspect the instrument cluster.	—
RR_WSPD (Right rear ABS wheel-speed sensor input)	KPH, MPH	<ul style="list-style-type: none"> <li>Vehicle stopped: <b>0 KPH, 0 MPH</b></li> <li>Vehicle running: Vehicle speed</li> </ul>	Inspect the ABS wheel-speed sensor.	AF, AI
SWA POS	°	<ul style="list-style-type: none"> <li>Steering wheel in neutral position (not turned): <b>0°</b></li> <li>Steering wheel turned to left: Changes <b>0°—negative</b></li> <li>Steering wheel turned to right: Changes <b>0°—positive</b></li> </ul>	Inspect the steering angle sensor.	—
TC LVAL	On/Off	<ul style="list-style-type: none"> <li>Solenoid valve activated: On</li> <li>Solenoid valve not activated: Off</li> </ul>	Inspect the DSC HU/CM.	—
TC RVAL	On/Off	<ul style="list-style-type: none"> <li>Solenoid valve activated: On</li> <li>Solenoid valve not activated: Off</li> </ul>	Inspect the DSC HU/CM.	—
TPI	%	<ul style="list-style-type: none"> <li>Closed throttle position: <b>0%</b></li> <li>Wide open throttle:</li> </ul>	Inspect the throttle position sensor.	—

		Changes according to throttle valve opening angle		
YAW_RATE	deg./s	<ul style="list-style-type: none"> <li>• Vehicle stopped or driving straight: <b>0 deg./s</b></li> <li>• Cornering to left: Changes <b>0 deg./s—negative</b></li> <li>• Cornering to right: Changes <b>0 deg./s—positive</b></li> </ul>	Inspect the combined sensor.	F

### Active Command Modes Table

Command name	Output part	Operation	Operating condition	
LATACCEL	Combined sensor (lateral acceleration) initialization start-up	TRUE/FALSE	Ignition switch at ON	
LF_DSC_V	LF stability control solenoid valve	On/Off		
LF_INLET	LF inlet solenoid valve			
LF_OUTLET	LF outlet solenoid valve			
LF_TC_VLV	LF traction control solenoid valve			
LR_INLET	LR inlet solenoid valve			
LR_OUTLET	LR outlet solenoid valve			
PMP_MOTOR	Pump motor			
RF_DSC_V	RF stability control solenoid valve			
RF_INLET	RF inlet solenoid valve			
RF_OUTLET	RF outlet solenoid valve			
RF_TC_VLV	RF traction control solenoid valve			
RR_INLET	RR inlet solenoid valve			
RR_OUTLET	RR outlet solenoid valve			
SAS_CAL	Steering angle sensor initialization start-up			TRUE/FALSE
YAWRATE	Combined sensor (yaw rate) initialization start-up			On/Off

## DTC B1318 [DYNAMIC STABILITY CONTROL]

### CAUTION:

- If the battery voltage drops during the inspection, B1318 will be output as a current malfunction and the proper diagnosis cannot be made. Be careful not to let the battery voltage drop.

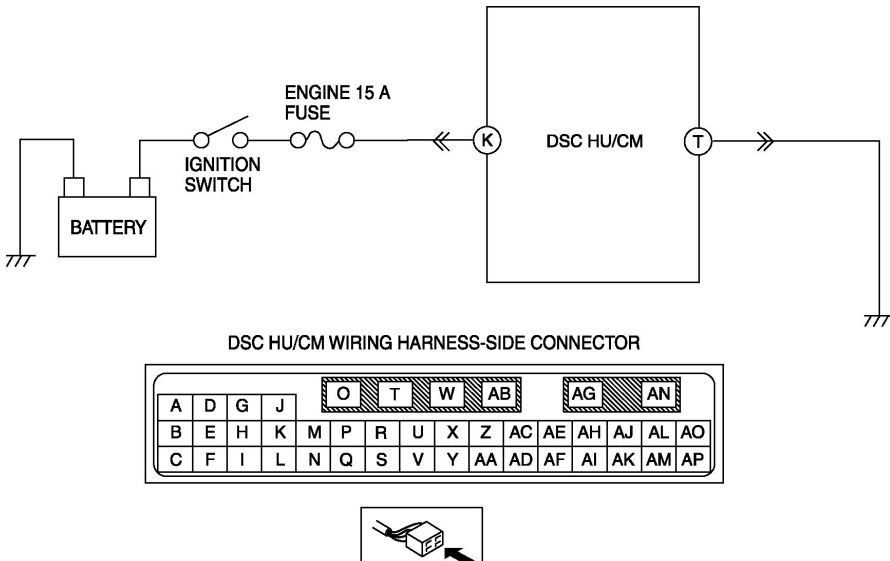
DTC	B1318	Power supply																																										
<b>DETECTION CONDITION</b>	<ul style="list-style-type: none"> <li>The voltage at DSC HU/CM terminal K is <b>approx. 10 V or less</b> .</li> </ul>																																											
<b>POSSIBLE CAUSE</b>	<ul style="list-style-type: none"> <li>ENGINE 15 A fuse malfunction</li> <li>Open circuit or short to ground in the wiring harness between the DSC HU/CM terminal K and the battery</li> <li>Open circuit or faulty ground in the wiring harness between the DSC HU/CM terminal T and the body ground</li> <li>Battery deterioration</li> <li>Generator malfunction</li> <li>Poor connection at connectors (female terminal)</li> </ul>																																											
 <p style="text-align: center;">DSC HU/CM WIRING HARNESS-SIDE CONNECTOR</p> <table border="1" style="margin-left: auto; margin-right: auto;"> <tr> <td>A</td><td>D</td><td>G</td><td>J</td> <td>O</td><td>T</td><td>W</td><td>AB</td> <td>AG</td><td>AN</td> </tr> <tr> <td>B</td><td>E</td><td>H</td><td>K</td> <td>M</td><td>P</td><td>R</td><td>U</td> <td>X</td><td>Z</td> <td>AC</td><td>AE</td><td>AH</td><td>AJ</td><td>AL</td><td>AO</td> </tr> <tr> <td>C</td><td>F</td><td>I</td><td>L</td> <td>N</td><td>Q</td><td>S</td><td>V</td> <td>Y</td><td>AA</td><td>AD</td><td>AF</td><td>AI</td><td>AK</td><td>AM</td><td>AP</td> </tr> </table>			A	D	G	J	O	T	W	AB	AG	AN	B	E	H	K	M	P	R	U	X	Z	AC	AE	AH	AJ	AL	AO	C	F	I	L	N	Q	S	V	Y	AA	AD	AF	AI	AK	AM	AP
A	D	G	J	O	T	W	AB	AG	AN																																			
B	E	H	K	M	P	R	U	X	Z	AC	AE	AH	AJ	AL	AO																													
C	F	I	L	N	Q	S	V	Y	AA	AD	AF	AI	AK	AM	AP																													

### Diagnostic procedure

STEP	INSPECTION		ACTION
1	<b>INSPECT BATTERY VOLTAGE</b> <ul style="list-style-type: none"> <li>Is the battery terminal voltage normal?</li> </ul>	Yes	Make sure that battery terminal connection is normal.  Go to the next step.



	normal?	No	Charge or replace the battery, then go to Step 6.
2	<b>INSPECT BATTERY GRAVITY</b> <ul style="list-style-type: none"> <li>Is battery specific gravity as specified?</li> </ul>	Yes	Go to the next step.
		No	Replace the battery, then go to Step 6.
3	<b>INSPECT CHARGING SYSTEM</b> <ul style="list-style-type: none"> <li>Are the generator and drive belt tensions normal?</li> </ul>	Yes	Go to the next step.
		No	Adjust the drive belt tension if necessary. Replace the generator and/or drive belt if necessary.
4	<b>INSPECT DSC HU/CM POWER SUPPLY FOR OPEN CIRCUIT</b> <ul style="list-style-type: none"> <li>Start the engine.</li> <li>Measure the voltage between DSC HU/CM terminal K and ground.</li> <li>Is the voltage <b>above 10 V</b> ?</li> </ul>	Yes	Go to the next step.
		No	Repair or replace the wiring harness for open circuit between DSC HU/CM and ground, then go to Step 6.
5	<b>INSPECT DSC HU/CM GROUND FOR POOR GROUND OR OPEN CIRCUIT</b> <ul style="list-style-type: none"> <li>Turn the ignition switch off.</li> <li>Measure the resistance between ground and DSC HU/CM terminal T.</li> <li>Is the resistance <b>within 0—1 ohm</b> ?</li> </ul>	Yes	Go to the next step.
		No	<p>If there is no continuity:</p> <ul style="list-style-type: none"> <li>Repair or replace the wiring harness for open circuit between the DSC HU/CM and ground, then go to the next step.</li> </ul> <p>If resistance is not <b>within 0—1 ohm</b> :</p> <ul style="list-style-type: none"> <li>Repair or replace harness for poor ground then go to the next step.</li> </ul>
6	<b>VERIFY TROUBLESHOOTING COMPLETED</b> <ul style="list-style-type: none"> <li>Make sure to reconnect all disconnected connectors.</li> <li>Clear the DTC from the memory.</li> <li>Is the same DTC present?</li> </ul>	Yes	Replace the DSC HU/CM, then go to the next step.
		No	Go to the next step.
7	<b>VERIFY AFTER REPAIR PROCEDURE</b> <ul style="list-style-type: none"> <li>Are any other DTCs present?</li> </ul>	Yes	Go to the applicable DTC inspection.
		No	DTC troubleshooting completed.

## DTC B1342 [DYNAMIC STABILITY CONTROL]

DTC	B1342	DSC HU/CM
<b>DETECTION CONDITION</b>	<ul style="list-style-type: none"> <li>The DSC HU/CM on-board diagnostic function detects control module malfunction.</li> </ul>	
<b>POSSIBLE CAUSE</b>	<ul style="list-style-type: none"> <li>DSC HU/CM internal malfunction</li> </ul>	

### Diagnostic procedure

STEP	INSPECTION	ACTION	
1	<b>VERIFY CURRENT STATUS OF MALFUNCTION</b> <ul style="list-style-type: none"> <li>Clear the DTC from the memory.</li> <li>Start the engine and drive the vehicle at <b>10 km/h {6.2 mph} or more</b> .</li> <li>Is the same DTC present?</li> </ul>	Yes	Replace the DSC HU/CM, then go to the next step.
		No	Go to the next step.
2	<b>VERIFY AFTER REPAIR PROCEDURE</b> <ul style="list-style-type: none"> <li>Are any other DTCs present?</li> </ul>	Yes	Go to the applicable DTC inspection.
		No	DTC troubleshooting completed.

# DTC B1484, C1953 [DYNAMIC STABILITY CONTROL]

## CAUTION:

- If the battery voltage drops during the inspection, B1318 will be output as a current malfunction and the proper diagnosis cannot be made. Be careful not to let the battery voltage drop.

DTC	B1484, C1953	Brake switch
<b>DETECTION CONDITION</b>	<ul style="list-style-type: none"> <li>B1484                             <ul style="list-style-type: none"> <li>Open circuit in the wiring harness between the DSC HU/CM terminal and the brake switch terminal</li> </ul> </li> <li>C1953                             <ul style="list-style-type: none"> <li>Brake switch ON signal is not input when the brake fluid pressure sensor signal reaches the specified value.</li> </ul> </li> </ul>	
<b>POSSIBLE CAUSE</b>	<ul style="list-style-type: none"> <li>Brake switch malfunction</li> <li>Open circuit in the wiring harness between the DSC HU/CM terminal AD and the brake switch terminal D</li> </ul>	
<p>The diagram illustrates the electrical circuit for the brake switch. It shows the DSC HU/CM unit connected to terminal AD, which is linked to terminal D of the Brake Switch. The Brake Switch is also connected to terminal B, which is connected to the Battery. The Battery is grounded. Below the diagram are two terminal block diagrams: the DSC HU/CM Wiring Harness-Side Connector and the Brake Switch Wiring Harness-Side Connector. The DSC HU/CM connector shows terminals A through AP, with O, T, W, AB, AG, and AN highlighted. The Brake Switch connector shows terminals C, A, D, and B. Arrows indicate the location of the connectors on the respective components.</p>		

## DTC B2477 [DYNAMIC STABILITY CONTROL]

DTC	B2477	DSC HU/CM configuration
<b>DETECTION CONDITION</b>	<ul style="list-style-type: none"> <li>Configuration setting failure is detected.</li> </ul>	
<b>POSSIBLE CAUSE</b>	<ul style="list-style-type: none"> <li>Module configuration procedure was not completed properly.</li> </ul>	

### Diagnostic procedure

STEP	INSPECTION		ACTION
1	<b>VERIFY CONFIGURATION</b> <ul style="list-style-type: none"> <li>Has the DSC HU/CM configuration been performed?</li> </ul>	Yes	Go to the next step.
		No	Perform configuration using the WDS or equivalent.
2	<b>VERIFY DTC TROUBLESHOOTING COMPLETED</b> <ul style="list-style-type: none"> <li>Clear the DTC from the memory.</li> <li>Is the same DTC present?</li> </ul>	Yes	Repeat the inspection from Step 1. If the malfunction recurs, replace the DSC HU/CM.
		No	Go to the next step.
3	<b>VERIFY AFTER REPAIR PROCEDURE</b> <ul style="list-style-type: none"> <li>Are any other DTCs present?</li> </ul>	Yes	Go to the applicable DTC inspection.
		No	DTC troubleshooting completed.

# DTC C1093 [DYNAMIC STABILITY CONTROL]

DTC	C1093	DSC OFF switch
<b>DETECTION CONDITION</b>	<ul style="list-style-type: none"> <li>Continuous ON signal from the DSC OFF switch for <b>5 s or more</b> is detected.</li> </ul>	
<b>POSSIBLE CAUSE</b>	<ul style="list-style-type: none"> <li>The driver pressed and held the DSC OFF switch for <b>5 s or more</b> .</li> <li>Short to ground in the wiring harness between the DSC HU/CM terminal AP and the DSC OFF switch terminal C</li> <li>DSC OFF switch malfunction</li> </ul>	

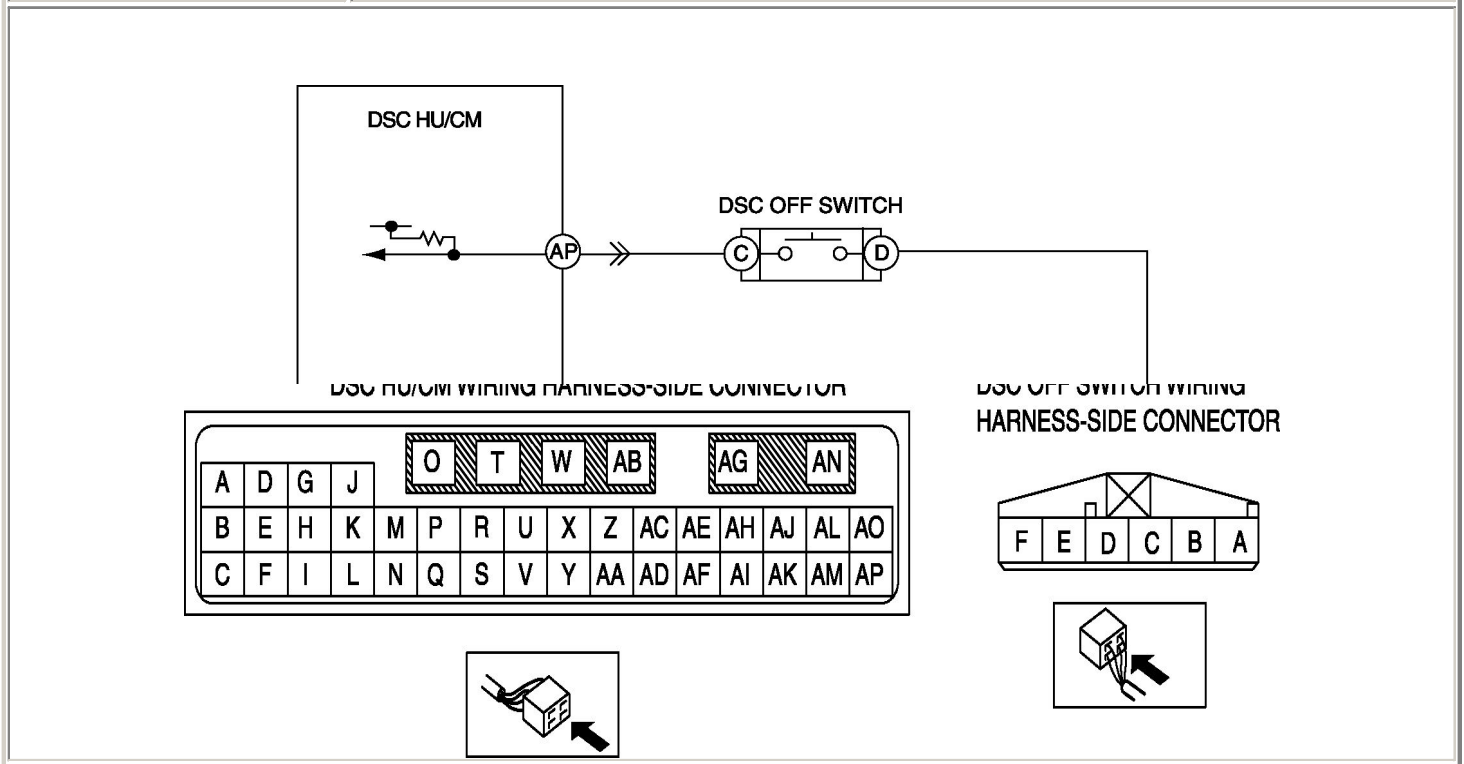

# DTC C1095, C1096 [DYNAMIC STABILITY CONTROL]

<b>DTC</b>	<b>C1095, C1096</b>	<b>Pump motor, motor relay,</b>
------------	---------------------	---------------------------------

<b>DETECTION CONDITION</b>	<ul style="list-style-type: none"> <li>• C1095             <ul style="list-style-type: none"> <li>▪ DSC motor monitor signal does not correspond to DSC HU/CM OFF signal.</li> </ul> </li> <li>• C1096             <ul style="list-style-type: none"> <li>▪ DSC motor monitor signal does not correspond to DSC HU/CM ON signal.</li> <li>▪ DSC motor monitor OFF signal is input within specified time limit when the motor signal is switched from ON to OFF by DSC HU/CM.</li> </ul> </li> </ul>
----------------------------	---

<b>POSSIBLE CAUSE</b>	<ul style="list-style-type: none"> <li>• ABS/DSC 60 A fuse malfunction</li> <li>• Open circuit or short to ground in the wiring harness between the battery and the DSC HU/CM terminal AG</li> <li>• Open circuit in the wiring harness between the DSC HU/CM terminal AN and the body ground</li> <li>• Open or short circuit in the DSC HU/CM internal motor relay, or stuck motor relay</li> <li>• Open or short circuit in the DSC HU/CM internal pump motor, or frozen pump motor</li> <li>• Poor connection at connectors (female terminal)</li> </ul>
-----------------------	--

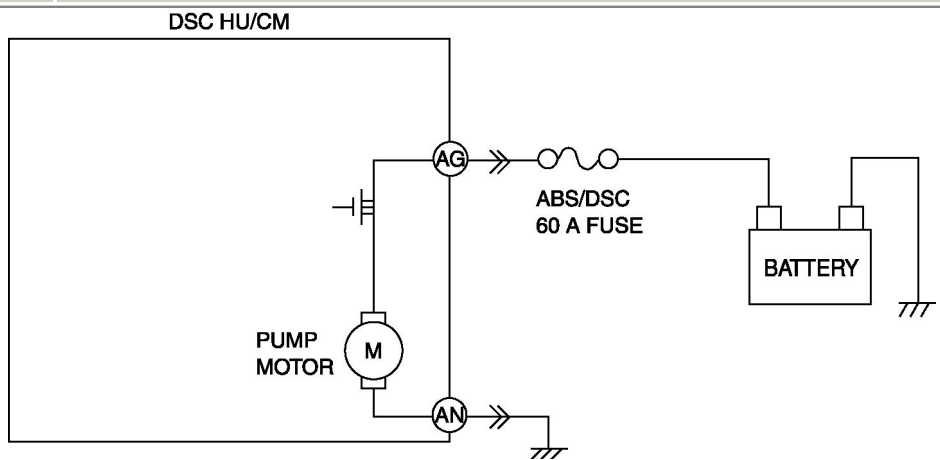

DSC HU/CM WIRING HARNESS-SIDE CONNECTOR

A	D	G	J	O	T	W	AB	AG	AN						
B	E	H	K	M	P	R	U	X	Z	AC	AE	AH	AJ	AL	AO
C	F	I	L	N	Q	S	V	Y	AA	AD	AF	AI	AK	AM	AP



## DTC C1119, C1134 [DYNAMIC STABILITY CONTROL]

DTC	C1119, C1134	PCM, TCM communication																						
<b>DETECTION CONDITION</b>	<ul style="list-style-type: none"> <li>• C1119                             <ul style="list-style-type: none"> <li>▪ The engine speed signal from the PCM is not within specification.</li> <li>▪ The throttle angle signal from the PCM is not within specification.</li> </ul> </li> <li>• C1134                             <ul style="list-style-type: none"> <li>▪ The shift position signal from the PCM or TCM is not within specification.</li> </ul> </li> </ul>																							
<b>POSSIBLE CAUSE</b>	<ul style="list-style-type: none"> <li>• A torque reduction inhibit signal is sent from the PCM.</li> <li>• An abnormal signal is sent from the PCM and/or TCM.</li> </ul>																							
<p>Diagnostic procedure</p> <table border="1"> <thead> <tr> <th>STEP</th> <th>INSPECTION</th> <th colspan="2">ACTION</th> </tr> </thead> <tbody> <tr> <td rowspan="2">1</td> <td rowspan="2"> <b>INSPECT FOR PCM MALFUNCTION</b> <ul style="list-style-type: none"> <li>• Turn the ignition switch off.</li> <li>• Using the WDS or equivalent, perform the DTC inspection for the PCM and TCM.</li> <li>• Are any DTCs detected?</li> </ul> </td> <td>Yes</td> <td>Go to applicable DTC inspection.</td> </tr> <tr> <td>No</td> <td>Go to the next step.</td> </tr> <tr> <td rowspan="2">2</td> <td rowspan="2"> <b>VERIFY DTC TROUBLESHOOTING COMPLETED</b> <ul style="list-style-type: none"> <li>• Make sure to reconnect all disconnected connectors.</li> <li>• Clear the DTC from the memory.</li> <li>• Is the same DTC present?</li> </ul> </td> <td>Yes</td> <td>Repeat the inspection from Step 1. If the malfunction recurs, replace the DSC HU/CM.</td> </tr> <tr> <td>No</td> <td>Go to the next step.</td> </tr> <tr> <td rowspan="2">3</td> <td rowspan="2"> <b>VERIFY AFTER REPAIR PROCEDURE</b> <ul style="list-style-type: none"> <li>• Is any other DTCs present?</li> </ul> </td> <td>Yes</td> <td>Go to the applicable DTC inspection.</td> </tr> <tr> <td>No</td> <td>DTC troubleshooting completed.</td> </tr> </tbody> </table>			STEP	INSPECTION	ACTION		1	<b>INSPECT FOR PCM MALFUNCTION</b> <ul style="list-style-type: none"> <li>• Turn the ignition switch off.</li> <li>• Using the WDS or equivalent, perform the DTC inspection for the PCM and TCM.</li> <li>• Are any DTCs detected?</li> </ul>	Yes	Go to applicable DTC inspection.	No	Go to the next step.	2	<b>VERIFY DTC TROUBLESHOOTING COMPLETED</b> <ul style="list-style-type: none"> <li>• Make sure to reconnect all disconnected connectors.</li> <li>• Clear the DTC from the memory.</li> <li>• Is the same DTC present?</li> </ul>	Yes	Repeat the inspection from Step 1. If the malfunction recurs, replace the DSC HU/CM.	No	Go to the next step.	3	<b>VERIFY AFTER REPAIR PROCEDURE</b> <ul style="list-style-type: none"> <li>• Is any other DTCs present?</li> </ul>	Yes	Go to the applicable DTC inspection.	No	DTC troubleshooting completed.
STEP	INSPECTION	ACTION																						
1	<b>INSPECT FOR PCM MALFUNCTION</b> <ul style="list-style-type: none"> <li>• Turn the ignition switch off.</li> <li>• Using the WDS or equivalent, perform the DTC inspection for the PCM and TCM.</li> <li>• Are any DTCs detected?</li> </ul>	Yes	Go to applicable DTC inspection.																					
		No	Go to the next step.																					
2	<b>VERIFY DTC TROUBLESHOOTING COMPLETED</b> <ul style="list-style-type: none"> <li>• Make sure to reconnect all disconnected connectors.</li> <li>• Clear the DTC from the memory.</li> <li>• Is the same DTC present?</li> </ul>	Yes	Repeat the inspection from Step 1. If the malfunction recurs, replace the DSC HU/CM.																					
		No	Go to the next step.																					
3	<b>VERIFY AFTER REPAIR PROCEDURE</b> <ul style="list-style-type: none"> <li>• Is any other DTCs present?</li> </ul>	Yes	Go to the applicable DTC inspection.																					
		No	DTC troubleshooting completed.																					

# DTC C1145, C1155, C1165, C1175 [DYNAMIC STABILITY CONTROL]

<p><b>DTC</b></p>	<p><b>C1145</b> <b>C1155</b> <b>C1165</b> <b>C1175</b></p>	<p><b>RF ABS wheel-speed sensor (open circuit)</b> <b>LF ABS wheel-speed sensor (open circuit)</b> <b>RR ABS wheel-speed sensor (open circuit)</b> <b>LR ABS wheel-speed sensor (open circuit)</b></p>																																																																																																																																												
<p><b>DETECTION CONDITION</b></p>	<ul style="list-style-type: none"> <li>Open circuit has been detected in the ABS wheel-speed sensor or the ABS wheel-speed sensor wiring harness on any of the four vehicle wheels.</li> </ul>																																																																																																																																													
<p><b>POSSIBLE CAUSE</b></p>	<ul style="list-style-type: none"> <li>Open circuit in the wiring harness between the following DSC HU/CM terminal and the ABS wheel-speed sensor terminal: <ul style="list-style-type: none"> <li>DSC HU/CM terminal AC—RF ABS wheel-speed sensor terminal A</li> <li>DSC HU/CM terminal AE—RF ABS wheel-speed sensor terminal B</li> <li>DSC HU/CM terminal AL—LF ABS wheel-speed sensor terminal A</li> <li>DSC HU/CM terminal AJ—LF ABS wheel-speed sensor terminal B</li> <li>DSC HU/CM terminal AF—RR ABS wheel-speed sensor terminal A</li> <li>DSC HU/CM terminal AI—RR ABS wheel-speed sensor terminal B</li> <li>DSC HU/CM terminal AH—LR ABS wheel-speed sensor terminal A</li> <li>DSC HU/CM terminal AK—LR ABS wheel-speed sensor terminal B</li> </ul> </li> <li>ABS wheel-speed sensor malfunction</li> <li>Poor connection at connectors (female terminal)</li> </ul>																																																																																																																																													
<div style="text-align: center;"> <p>DSC HU/CM</p> <p><b>DSC HU/CM WIRING HARNESS-SIDE CONNECTOR</b></p> <table border="1" style="margin-left: auto; margin-right: auto;"> <tr> <td>A</td><td>D</td><td>G</td><td>J</td><td>O</td><td>T</td><td>W</td><td>AB</td><td>AG</td><td>AN</td> </tr> <tr> <td>B</td><td>E</td><td>H</td><td>K</td><td>M</td><td>P</td><td>R</td><td>U</td><td>X</td><td>Z</td> </tr> <tr> <td>C</td><td>F</td><td>I</td><td>L</td><td>N</td><td>Q</td><td>S</td><td>V</td><td>Y</td><td>AA</td> </tr> <tr> <td></td><td></td><td></td><td></td><td></td><td></td><td></td><td></td><td></td><td>AD</td> </tr> <tr> <td></td><td></td><td></td><td></td><td></td><td></td><td></td><td></td><td></td><td>AE</td> </tr> <tr> <td></td><td></td><td></td><td></td><td></td><td></td><td></td><td></td><td></td><td>AH</td> </tr> <tr> <td></td><td></td><td></td><td></td><td></td><td></td><td></td><td></td><td></td><td>AJ</td> </tr> <tr> <td></td><td></td><td></td><td></td><td></td><td></td><td></td><td></td><td></td><td>AL</td> </tr> <tr> <td></td><td></td><td></td><td></td><td></td><td></td><td></td><td></td><td></td><td>AO</td> </tr> <tr> <td></td><td></td><td></td><td></td><td></td><td></td><td></td><td></td><td></td><td>AF</td> </tr> <tr> <td></td><td></td><td></td><td></td><td></td><td></td><td></td><td></td><td></td><td>AI</td> </tr> <tr> <td></td><td></td><td></td><td></td><td></td><td></td><td></td><td></td><td></td><td>AK</td> </tr> <tr> <td></td><td></td><td></td><td></td><td></td><td></td><td></td><td></td><td></td><td>AM</td> </tr> <tr> <td></td><td></td><td></td><td></td><td></td><td></td><td></td><td></td><td></td><td>AP</td> </tr> </table> <p><b>ABS WHEEL-SPEED SENSOR WIRING HARNESS-SIDE CONNECTOR</b></p> <p><b>FRONT</b>      <b>REAR</b></p> </div>			A	D	G	J	O	T	W	AB	AG	AN	B	E	H	K	M	P	R	U	X	Z	C	F	I	L	N	Q	S	V	Y	AA										AD										AE										AH										AJ										AL										AO										AF										AI										AK										AM										AP
A	D	G	J	O	T	W	AB	AG	AN																																																																																																																																					
B	E	H	K	M	P	R	U	X	Z																																																																																																																																					
C	F	I	L	N	Q	S	V	Y	AA																																																																																																																																					
									AD																																																																																																																																					
									AE																																																																																																																																					
									AH																																																																																																																																					
									AJ																																																																																																																																					
									AL																																																																																																																																					
									AO																																																																																																																																					
									AF																																																																																																																																					
									AI																																																																																																																																					
									AK																																																																																																																																					
									AM																																																																																																																																					
									AP																																																																																																																																					



# DTC C1148, C1158, C1168, C1178 [DYNAMIC STABILITY CONTROL]

<b>DTC</b>	<b>C1148</b>	<b>RF ABS wheel-speed sensor/ABS sensor rotor</b>
	<b>C1158</b>	<b>LF ABS wheel-speed sensor/ABS sensor rotor</b>
	<b>C1168</b>	<b>RR ABS wheel-speed sensor/ABS sensor rotor</b>
	<b>C1178</b>	<b>LR ABS wheel-speed sensor/ABS sensor rotor</b>

<b>DETECTION CONDITION</b>	<ul style="list-style-type: none"> <li>• Vehicle wheel speed signals of any of the four vehicle wheels indicate abnormal acceleration that exceeds specification.</li> <li>• Vehicle wheel speed signals of any of the four vehicle wheels indicate speed that exceeds specification.</li> </ul>
----------------------------	--

<b>POSSIBLE CAUSE</b>	<ul style="list-style-type: none"> <li>• ABS wheel-speed sensor malfunction (low output, metal shavings on sensor)</li> <li>• ABS sensor rotor malfunction (chipping of sensor rotor teeth)</li> <li>• Poor installation of ABS wheel speed sensor and/or sensor rotor (If the sensor rotor is installed at an angle, it may cause output of abnormal wave pattern at high speeds.)</li> <li>• Excessive clearance between the ABS wheel-speed sensor and sensor rotor</li> </ul>
-----------------------	---

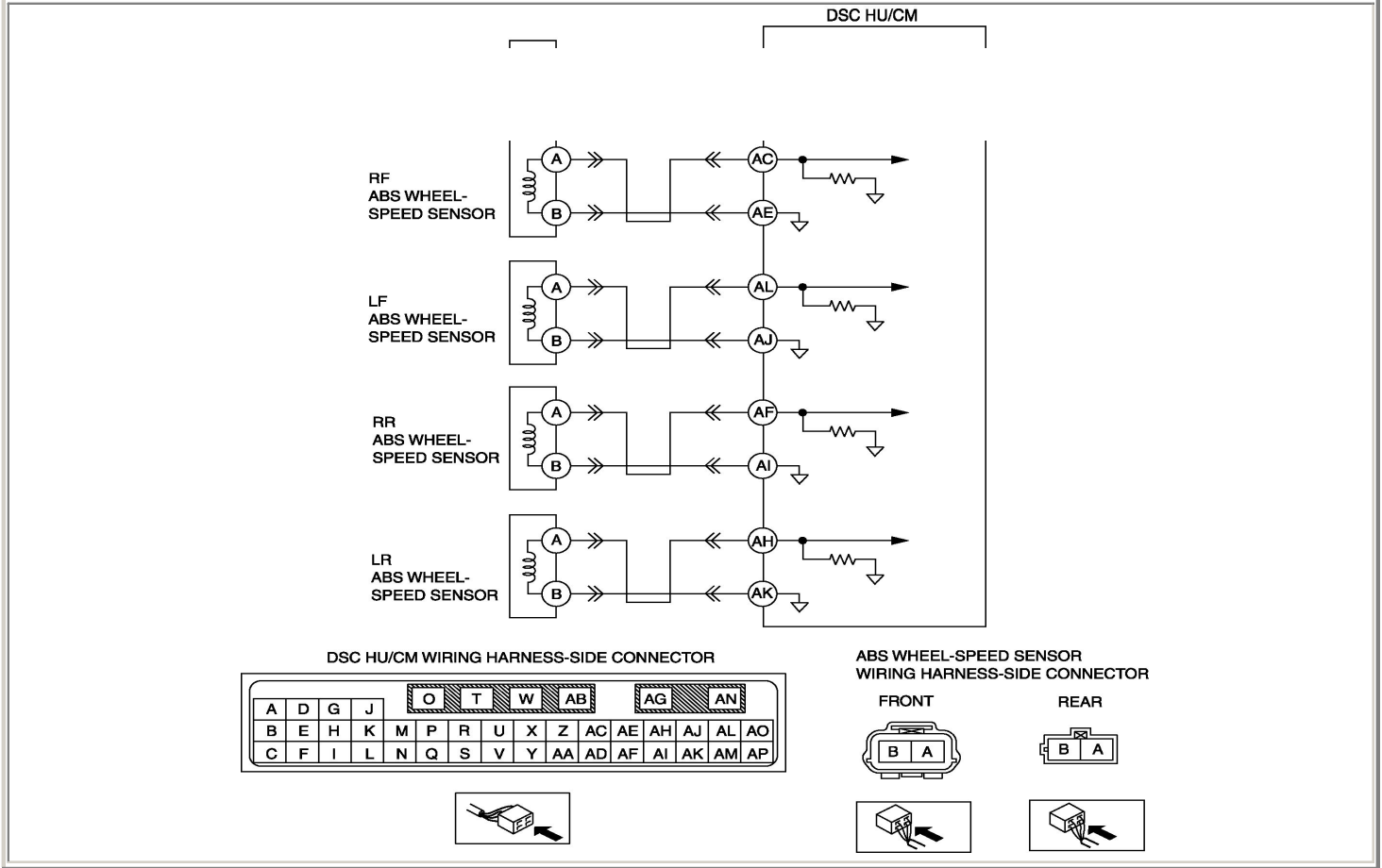

# DTC C1186, C1266 [DYNAMIC STABILITY CONTROL]

DTC	C1186, C1266	Valve relay
<p><b>DETECTION CONDITION</b></p>	<ul style="list-style-type: none"> <li>• C1186                             <ul style="list-style-type: none"> <li>▪ DSC HU/CM internal valve relay remains OFF when valve relay ON is commanded.</li> </ul> </li> <li>• C1266                             <ul style="list-style-type: none"> <li>▪ DSC HU/CM internal valve relay remains ON (stuck) when valve relay OFF is commanded.</li> </ul> </li> </ul>	
<p><b>POSSIBLE CAUSE</b></p>	<ul style="list-style-type: none"> <li>• DSC 30 A fuse malfunction</li> <li>• Open circuit or short to ground in the wiring harness between the battery and the DSC HU/CM terminal O</li> <li>• Open or short circuit in the DSC HU/CM internal valve relay, or stuck valve relay</li> <li>• Poor connection at connectors (female terminal)</li> </ul>	

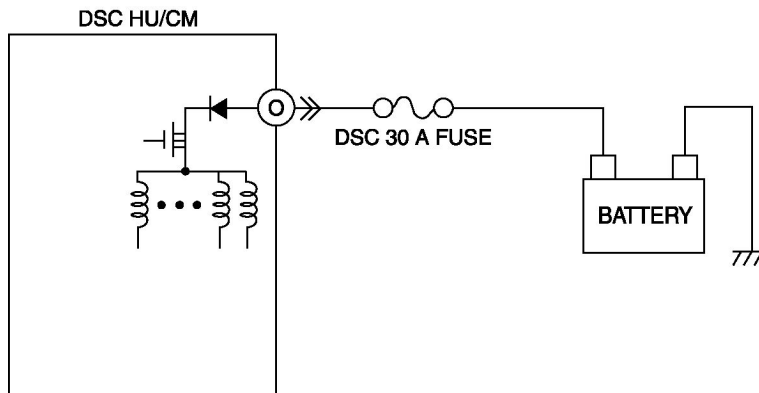

DSC HU/CM WIRING HARNESS-SIDE CONNECTOR

A	D	G	J	O	T	W	AB	AG	AN						
B	E	H	K	M	P	R	U	X	Z	AC	AE	AH	AJ	AL	AO
C	F	I	L	N	Q	S	V	Y	AA	AD	AF	AI	AK	AM	AP

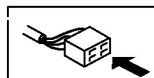

**DTC C1194, C1198, C1210, C1214, C1242, C1246, C1250, C1254, C1400, C1410, C1957, C1958 [DYNAMIC STABILITY CONTROL]**

<b>DTC</b>	<b>C 1194</b>	<b>LF outlet solenoid valve</b>
	<b>C 1198</b>	<b>LF inlet solenoid valve</b>
	<b>C 1210</b>	<b>RF outlet solenoid valve</b>
	<b>C 1214</b>	<b>RF inlet solenoid valve</b>
	<b>C 1242</b>	<b>LR outlet solenoid valve</b>
	<b>C 1246</b>	<b>RR outlet solenoid valve</b>
	<b>C 1250</b>	<b>LR inlet solenoid valve</b>
	<b>C 1254</b>	<b>RR inlet solenoid valve</b>
	<b>C 1400</b>	<b>RF traction switch solenoid valve</b>
	<b>C 1410</b>	<b>LF traction switch solenoid valve</b>
	<b>C 1957</b>	<b>RF DSC switch solenoid valve</b>
	<b>C 1958</b>	<b>LF DSC switch solenoid valve</b>
<b>DETECTION CONDITION</b>	<ul style="list-style-type: none"> <li>• Solenoid valve operation does not correspond to solenoid ON/OFF commands from the DSC HU/CM.</li> </ul>	
<b>POSSIBLE CAUSE</b>	<ul style="list-style-type: none"> <li>• Open or short circuit in the DSC HU/CM internal solenoid valves</li> <li>• Solenoid valve malfunction</li> <li>• Poor connection at connectors (female terminal)</li> </ul>	

# DTC C1222 [DYNAMIC STABILITY CONTROL]

## NOTE:

- DTC C1222 will be detected when a malfunctioning ABS wheel-speed sensor cannot be specified.

DTC	C1222	ABS wheel-speed sensor (slip monitor)
<b>DETECTION CONDITION</b>		<ul style="list-style-type: none"> <li>Difference between any vehicle wheel speeds exceeds specification when driving at a constant speed.</li> <li>ABS control operates for <b>60 s or more</b>.</li> </ul>
<b>POSSIBLE CAUSE</b>		<ul style="list-style-type: none"> <li>ABS wheel-speed sensor malfunction (low output, metal shavings on sensor)</li> <li>ABS sensor rotor malfunction (chipping of sensor rotor teeth)</li> <li>Poor installation of ABS wheel speed sensor and/or sensor rotor (If the sensor rotor is installed at an angle, it may cause output of abnormal wave pattern at high speeds.)</li> <li>Excessive clearance between the ABS wheel-speed sensor and sensor rotor</li> </ul>

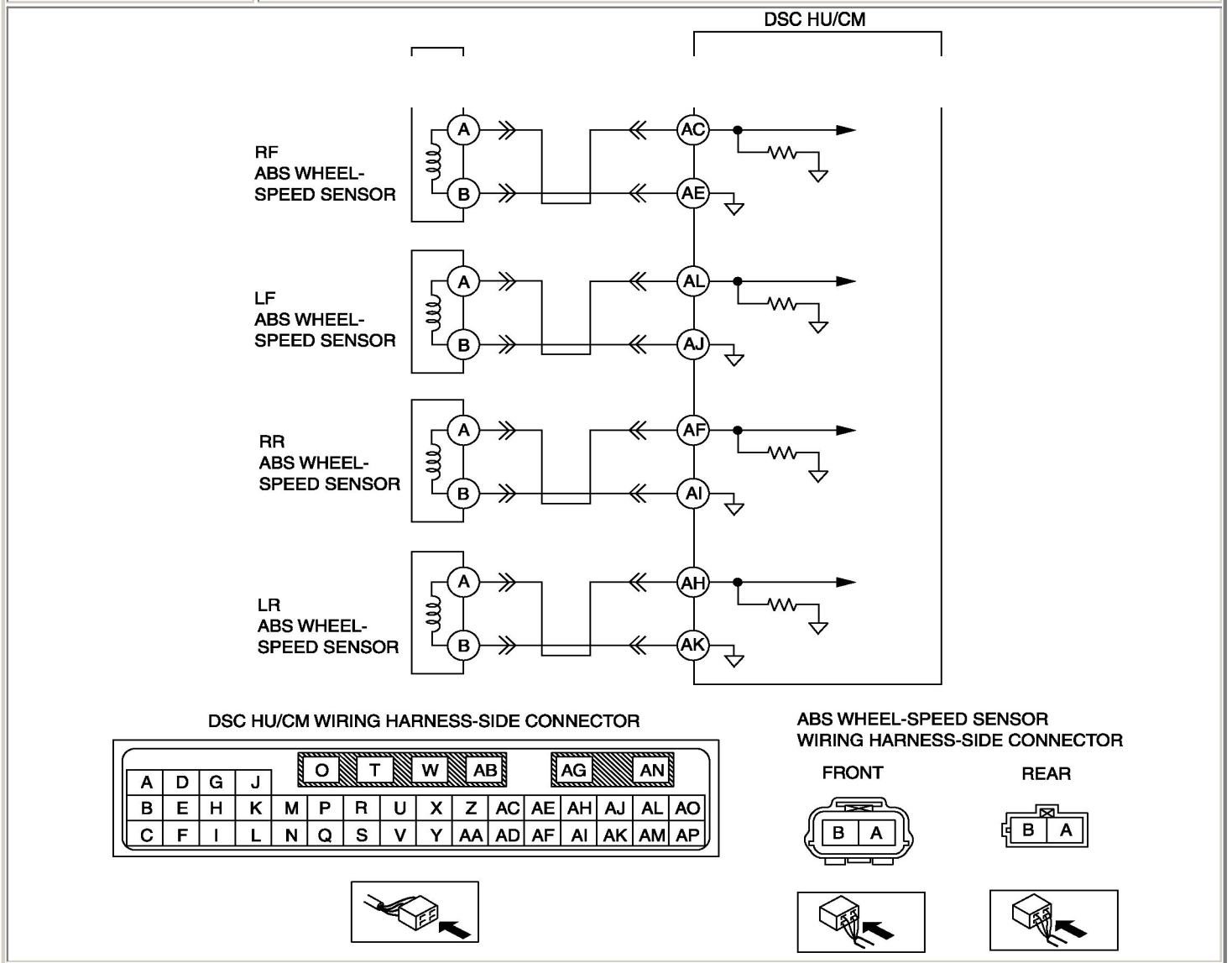

# DTC C1233, C1234, C1235, C1236 [DYNAMIC STABILITY CONTROL]

<b>DTC</b>	<b>C1233</b>	<b>LF ABS wheel-speed sensor (short to ground)</b>
	<b>C1234</b>	<b>RF ABS wheel-speed sensor (short to ground)</b>
	<b>C1235</b>	<b>RR ABS wheel-speed sensor (short to ground)</b>
	<b>C1236</b>	<b>LR ABS wheel-speed sensor (short to ground)</b>
<b>DETECTION CONDITION</b>		<ul style="list-style-type: none"> <li>• C1233, C1234, C1235, C1236             <ul style="list-style-type: none"> <li>▪ The vehicle wheel speed of any of the four vehicle wheels is <b>2.75 km/h {1.71 mph}</b> or less when driving at the specified vehicle speed or more.</li> </ul> </li> </ul>
<b>POSSIBLE CAUSE</b>		<ul style="list-style-type: none"> <li>• Short to ground in the wiring harness between the following DSC HU/CM terminal and the ABS wheel-speed sensor terminal:             <ul style="list-style-type: none"> <li>▪ DSC HU/CM terminal AC—RF ABS wheel-speed sensor terminal A</li> <li>▪ DSC HU/CM terminal AE—RF ABS wheel-speed sensor terminal B</li> <li>▪ DSC HU/CM terminal AL—LF ABS wheel-speed sensor terminal A</li> <li>▪ DSC HU/CM terminal AJ—LF ABS wheel-speed sensor terminal B</li> <li>▪ DSC HU/CM terminal AF—RR ABS wheel-speed sensor terminal A</li> <li>▪ DSC HU/CM terminal AI—RR ABS wheel-speed sensor terminal B</li> <li>▪ DSC HU/CM terminal AH—LR ABS wheel-speed sensor terminal A</li> <li>▪ DSC HU/CM terminal AK—LR ABS wheel-speed sensor terminal B</li> </ul> </li> <li>• ABS wheel-speed sensor malfunction</li> <li>• Poor connection at connectors (female terminal)</li> </ul>

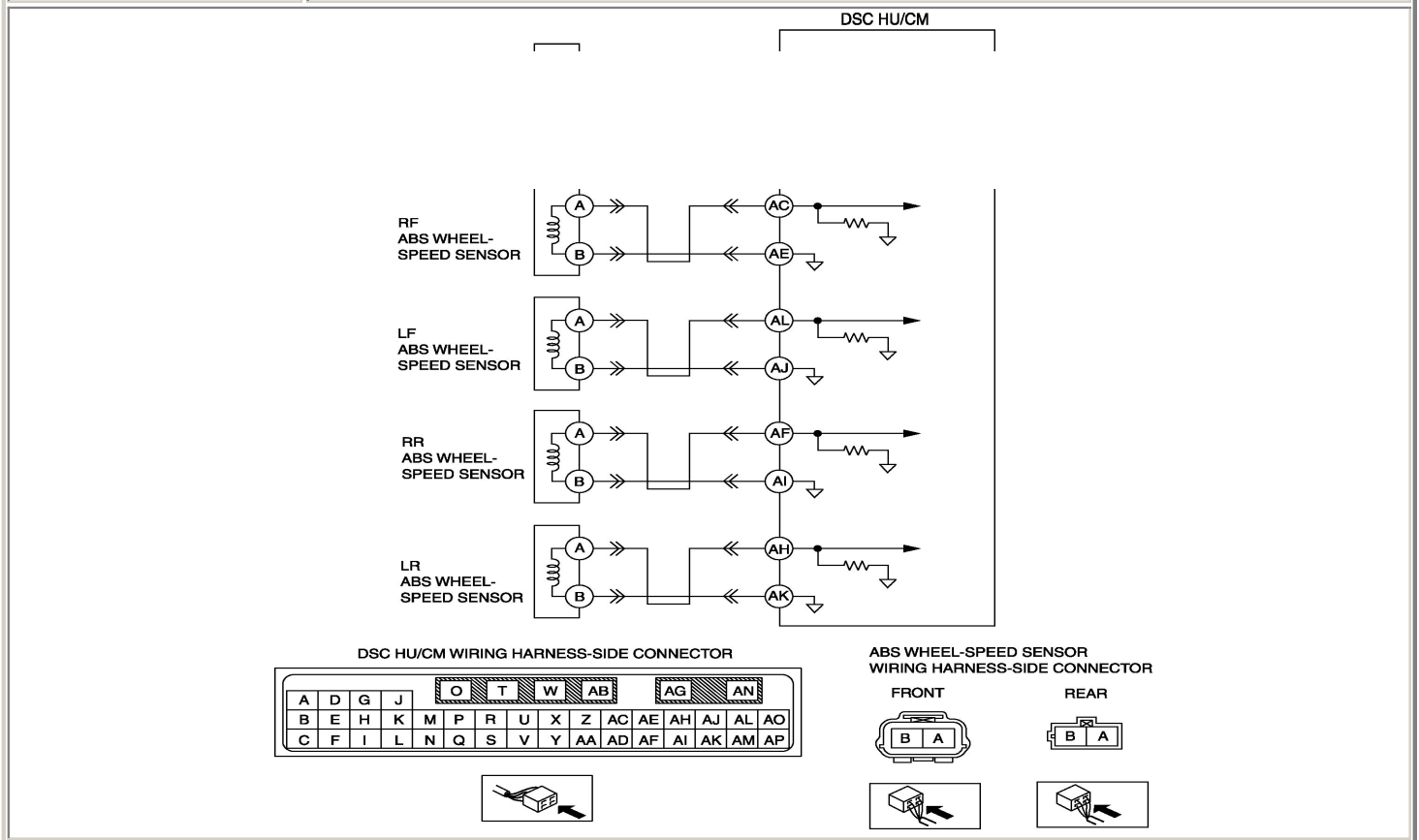

**DTC C1279, C1280, C1281, C1282, C1951, C1952, C1959, C2768 [DYNAMIC STABILITY CONTROL]**

DTC	C1279, C1280, C1281, C1282, C1951, C1952, C1959, C2768	Combined sensor
<p><b>DETECTION CONDITION</b></p>	<ul style="list-style-type: none"> <li>• C1279 <ul style="list-style-type: none"> <li>▪ The yaw rate value from the combined sensor (yaw rate part) exceeds specification while the vehicle is stopped or while accelerating from a standstill.</li> </ul> </li> <li>• C1280 <ul style="list-style-type: none"> <li>▪ The difference between the yaw rate value calculated by each sensor and the yaw rate value from the combined sensor (yaw rate part) exceeds specification.</li> </ul> </li> <li>• C1281 <ul style="list-style-type: none"> <li>▪ The difference between the lateral-G value calculated by each sensor and the lateral-G value from the combined sensor (lateral-G part) exceeds specification.</li> </ul> </li> <li>• C1282 <ul style="list-style-type: none"> <li>▪ Specified signal pattern from combined sensor has not output after the ignition switch is turned to the ON position.</li> </ul> </li> <li>• C1951 <ul style="list-style-type: none"> <li>▪ The monitor voltage from the combined sensor (lateral-G part) is not within specification.</li> </ul> </li> <li>• C1952 <ul style="list-style-type: none"> <li>▪ The monitor voltage from the combined sensor (yaw rate part) is not within specification.</li> </ul> </li> <li>• C1959 <ul style="list-style-type: none"> <li>▪ The lateral-G value from the combined sensor (lateral-G part) exceeds specification.</li> </ul> </li> <li>• C2768 <ul style="list-style-type: none"> <li>▪ There is an abnormality in the signal from the combined sensor (yaw rate part).</li> </ul> </li> </ul>	
<p><b>POSSIBLE CAUSE</b></p>	<ul style="list-style-type: none"> <li>• Open circuit in the wiring harness between DSC HU/CM terminal A and combined sensor terminal A or short circuit to ground</li> <li>• Open circuit in the wiring harness between DSC HU/CM terminal D and combined sensor terminal C or short circuit to ground</li> <li>• Open circuit in the wiring harness between DSC HU/CM terminal F and combined sensor terminal B or short circuit to ground</li> <li>• Open circuit in the wiring harness between DSC HU/CM terminal G and combined sensor terminal D or short circuit to ground</li> <li>• Open circuit in the wiring harness between DSC HU/CM terminal L and combined sensor terminal E or short circuit to ground</li> <li>• Open circuit in the wiring harness between DSC HU/CM terminal P and combined sensor terminal F</li> <li>• Combined sensor malfunction</li> <li>• Poor connection at connectors (female terminal)</li> </ul>	

# DTC C1288, C1290, C1440, C1730, C1954 [DYNAMIC STABILITY CONTROL]

<b>DTC</b>	<b>C1288, C1290, C1440, C1730, C1954</b>	<b>Brake fluid pressure sensor</b>
------------	--	------------------------------------

<b>DETECTION CONDITION</b>	<ul style="list-style-type: none"> <li>• C1288             <ul style="list-style-type: none"> <li>▪ The pressure from the brake fluid pressure sensor when the system starts up is not within specification.</li> </ul> </li> <li>• C1290             <ul style="list-style-type: none"> <li>▪ The pressure from the brake fluid pressure sensor when not braking exceeds specification.</li> </ul> </li> <li>• C1440             <ul style="list-style-type: none"> <li>▪ The difference between the estimated brake fluid pressure response calculated by each sensor and the brake fluid pressure response from the brake fluid pressure sensor is not within specification.</li> </ul> </li> <li>• C1730             <ul style="list-style-type: none"> <li>▪ The voltage to the brake fluid pressure sensor is not within specification.</li> </ul> </li> <li>• C1954             <ul style="list-style-type: none"> <li>▪ The output voltage from the brake fluid pressure sensor is not within specification.</li> </ul> </li> </ul>
----------------------------	---

<b>POSSIBLE CAUSE</b>	<ul style="list-style-type: none"> <li>• Open or short circuit in the wiring harness between DSC HU/CM terminal B and brake fluid pressure sensor terminal B</li> <li>• Open or short circuit in the wiring harness between DSC HU/CM terminal C and brake fluid pressure sensor terminal C</li> <li>• Open circuit in the wiring harness between DSC HU/CM terminal E and brake fluid pressure sensor terminal A</li> <li>• Malfunction in the brake fluid pressure sensor</li> <li>• Poor connection at connectors (female terminal)</li> </ul>
-----------------------	---

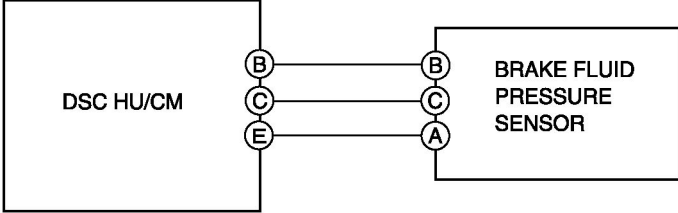

**DSC HU/CM WIRING HARNESS-SIDE CONNECTOR**

A	D	G	J	O	T	W	AB	AG	AN						
B	E	H	K	M	P	R	U	X	Z	AC	AE	AH	AJ	AL	AO
C	F	I	L	N	Q	S	V	Y	AA	AD	AF	AI	AK	AM	AP

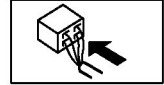
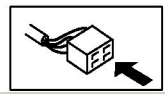
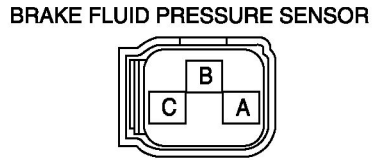

# DTC C1295, C1307, C1937, C1938, C1956 [DYNAMIC STABILITY CONTROL]

<b>DTC</b>	<b>C1295, C1307, C1937, C1938, C1956</b>	<b>Steering angle sensor</b>
<b>DETECTION CONDITION</b>	<ul style="list-style-type: none"> <li>• C1295             <ul style="list-style-type: none"> <li>▪ The steering angle sensor detects an internal abnormality.</li> </ul> </li> <li>• C1307             <ul style="list-style-type: none"> <li>▪ The steering angle sensor detects an abnormality in the signal.</li> </ul> </li> <li>• C1937             <ul style="list-style-type: none"> <li>▪ The difference between the steering angle calculated by each sensor and the steering angle from the steering angle sensor exceeds specification.</li> </ul> </li> <li>• C1938             <ul style="list-style-type: none"> <li>▪ The difference between the steering angle previously received and the steering angle received at this time is not within specification.</li> <li>▪ The signal from the steering angle sensor remains unchanged when the steering angle is turned to the right and left.</li> </ul> </li> <li>• C1956             <ul style="list-style-type: none"> <li>▪ There is no signal received from the steering angle sensor.</li> </ul> </li> </ul>	
<b>POSSIBLE CAUSE</b>	<ul style="list-style-type: none"> <li>• Improper installation or positioning of the steering angle sensor</li> <li>• Steering angle sensor malfunction</li> <li>• Poor connection at connectors (female terminal)</li> </ul>	

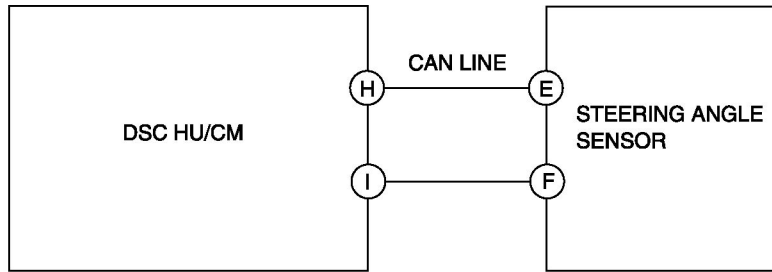

DSC HU/CM WIRING HARNESS-SIDE CONNECTOR

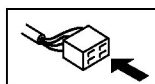
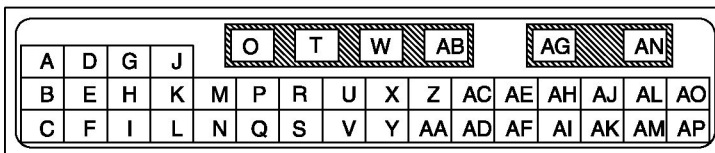

STEERING ANGLE SENSOR WIRING HARNESS-SIDE CONNECTOR

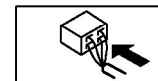
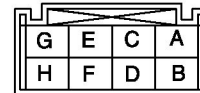



## DTC C1306 [DYNAMIC STABILITY CONTROL]

DTC	C1306	Steering angle sensor (abnormal initialization)
<b>DETECTION CONDITION</b>	<ul style="list-style-type: none"> <li>The steering angle sensor detects that the initialization procedure has not been performed.</li> </ul>	
<b>POSSIBLE CAUSE</b>	<ul style="list-style-type: none"> <li>The initialization procedure for the steering angle sensor has not been performed.</li> <li>Steering angle sensor malfunction</li> <li>The negative battery cable connector was disconnected previously.</li> </ul>	

### Diagnostic procedure

STEP	INSPECTION	ACTION	
1	<b>VERIFY OTHER DTC HAS BEEN RECORDED</b> <ul style="list-style-type: none"> <li>Has DTC C2778 also been stored?</li> </ul>	Yes	Go to the applicable DTC inspection.
		No	Go to the next step.
2	<b>VERIFY INITIALIZATION PROCEDURE.</b> <ul style="list-style-type: none"> <li>Has the steering angle sensor initialization procedure been performed?</li> </ul>	Yes	Go to the next step.
		No	Perform the steering angle sensor initialization procedure, then go to the next step.
3	<b>VERIFY DTC TROUBLESHOOTING COMPLETED</b> <ul style="list-style-type: none"> <li>Clear the DTC from the memory.</li> <li>Is the same DTC present?</li> </ul>	Yes	Repeat the inspection from Step 1. If the malfunction occurs again, replace the steering angle sensor.
		No	Go to the next step.
4	<b>VERIFY AFTER REPAIR PROCEDURE</b> <ul style="list-style-type: none"> <li>Are any other DTCs present?</li> </ul>	Yes	Go to the applicable DTC inspection.
		No	DTC troubleshooting completed.

## DTC C1805 [DYNAMIC STABILITY CONTROL]

<b>DTC</b>	<b>C1805</b>	<b>Incorrect DSC HU/CM installed</b>
<b>DETECTION CONDITION</b>	<ul style="list-style-type: none"> <li>The programmed vehicle information and the data received from the CAN do not correspond.</li> </ul>	
<b>POSSIBLE CAUSE</b>	<ul style="list-style-type: none"> <li>The correct DSC HU/CM is not installed.</li> </ul>	

### Diagnostic procedure

STEP	INSPECTION	ACTION	
1	<b>VERIFY THAT THE CORRECT DSC HU/CM IS INSTALLED</b> <ul style="list-style-type: none"> <li>Verify the part number of the DSC HU/CM.</li> <li>Is the part number correct?</li> </ul>	Yes	Go to the next step.
		No	After replacing the DSC HU/CM, go to Step 3.
2	<b>PERFORM CONFIGURATION</b> <ul style="list-style-type: none"> <li>Was configuration performed normally?</li> </ul>	Yes	Go to the next step.
		No	Replace the DSC HU/CM, then go to the next step.
3	<b>VERIFY DTC TROUBLESHOOTING COMPLETED</b> <ul style="list-style-type: none"> <li>Make sure to reconnect all disconnected connectors.</li> <li>Clear the DTC from the memory.</li> <li>Is the same DTC present?</li> </ul>	Yes	Repeat the inspection from Step 1. If the malfunction recurs, replace the DSC HU/CM.
		No	Go to the next step.
4	<b>VERIFY AFTER REPAIR PROCEDURE</b> <ul style="list-style-type: none"> <li>Are any other DTCs present?</li> </ul>	Yes	Go to the applicable DTC inspection.
		No	DTC troubleshooting completed.

## DTC C1994 [DYNAMIC STABILITY CONTROL]

DTC	C1994	DSC control
<b>DETECTION CONDITION</b>	<ul style="list-style-type: none"> <li>DSC control for the front wheels continues for <b>10 s or more</b> .</li> <li>During DSC control, the pressure increase operation to any of the all four wheels does not occur for <b>1.3 s or more</b> .</li> </ul>	
<b>POSSIBLE CAUSE</b>	<ul style="list-style-type: none"> <li>This does not indicate a malfunction since constant control over extended period of time is inhibited to protect the DSC solenoid valve inside the DSC HU.</li> </ul>	

### Diagnostic procedure

STEP	INSPECTION	ACTION
1	<b>VERIFY DTC TROUBLESHOOTING COMPLETED</b> <ul style="list-style-type: none"> <li>Clear the DTC from the memory.</li> <li>Are the same DTCs present?</li> </ul>	Yes Replace the DSC HU/CM, then go to the next step.)
		No Go to the next step.
2	<b>VERIFY AFTER REPAIR PROCEDURE</b> <ul style="list-style-type: none"> <li>Are any other DTCs present?</li> </ul>	Yes Go to the applicable DTC inspection.
		No DTC troubleshooting completed.

# DTC C2778 [DYNAMIC STABILITY CONTROL]

<b>DTC</b>	<b>C2778</b>	<b>Steering angle sensor (abnormal battery voltage)</b>
<b>DETECTION CONDITION</b>	<ul style="list-style-type: none"> <li>The steering angle sensor detects an abnormality (open circuit) in the battery power supply (constant power supply).</li> </ul>	
<b>POSSIBLE CAUSE</b>	<ul style="list-style-type: none"> <li>BTN 30 A fuse malfunction</li> <li>DSC 7.5A fuse malfunction</li> <li>Open circuit in the wiring harness between the battery and steering angle sensor terminal B</li> <li>Poor connection at connectors (female terminal)</li> </ul>	

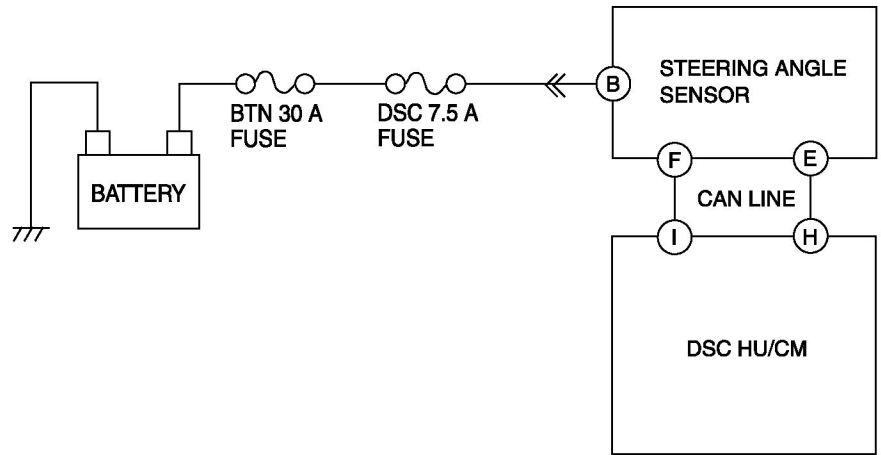

DSC HU/CM WIRING HARNESS-SIDE CONNECTOR

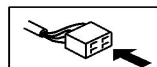
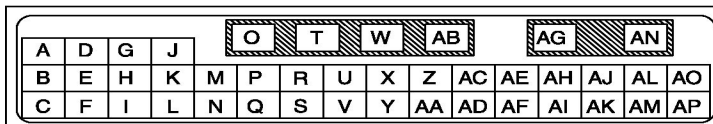

STEERING ANGLE SENSOR WIRING HARNESS-SIDE CONNECTOR

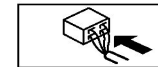

Notes:

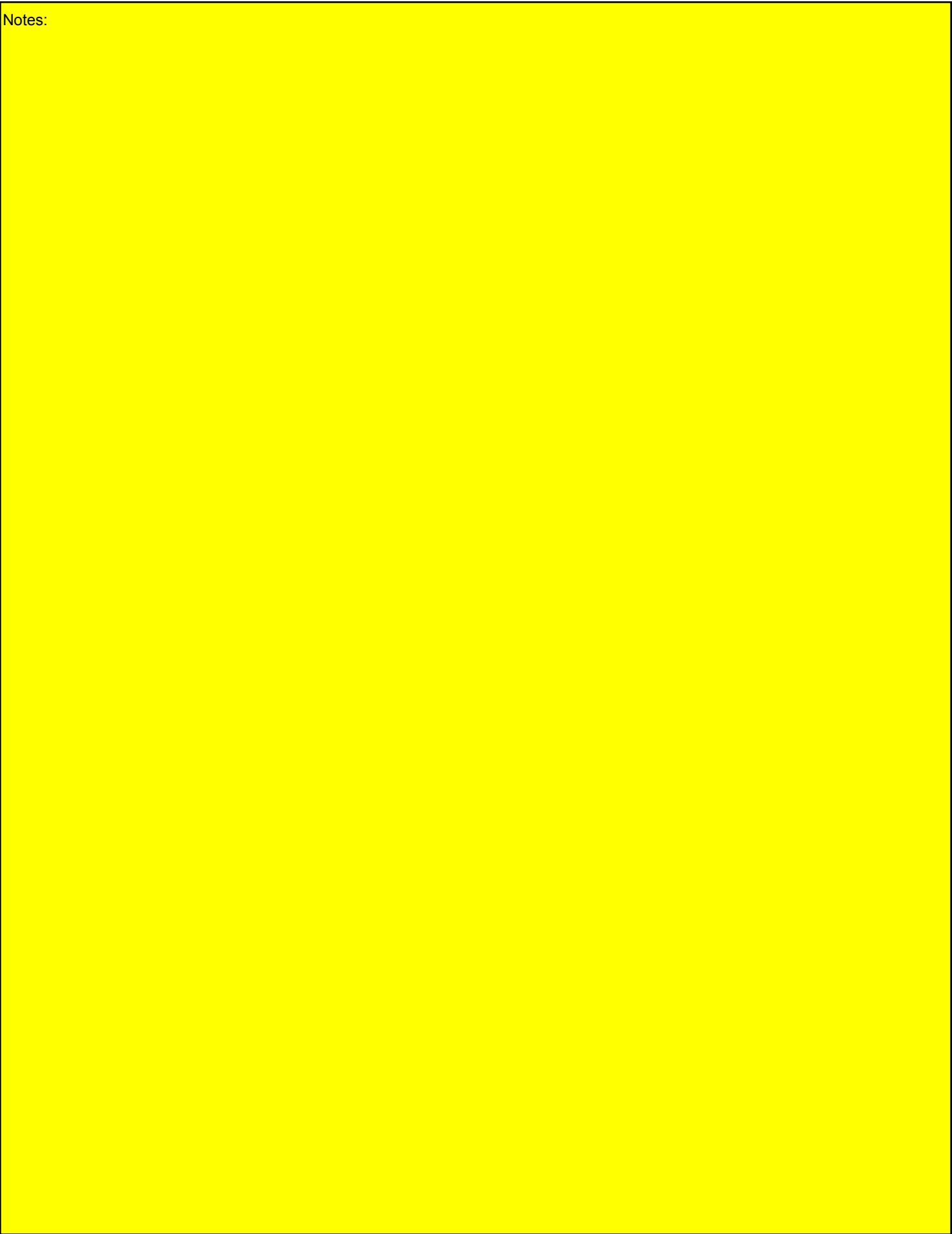

# NO.1 NEITHER ABS WARNING LIGHT NOR BRAKE SYSTEM WARNING LIGHT ILLUMINATE WHEN IGNITION SWITCH TURNED TO ON POSITION

<b>1</b>	<b>ABS warning light and BRAKE system warning light do not illuminate when the ignition switch is turned to ON position.</b>
<b>[TROUBLESHOOTING HINTS]</b>	
<ul style="list-style-type: none"> <li>• <b>Malfunction of instrument cluster or ABS HU/CM</b></li> <li>• <b>Improper configuration (instrument cluster)</b></li> </ul>	

STEP	INSPECTION		ACTION
1	VERIFY WHETHER MALFUNCTION IS IN COMMON POWER SUPPLY OF WARNING LIGHTS AND INDICATOR LIGHTS, OR IN OTHER WARNING LIGHTS AND INDICATOR LIGHTS  <ul style="list-style-type: none"> <li>• Do other warning and indicator lights illuminate when the ignition switch is turned to the ON position?</li> </ul>	Yes	Go to step 4.
		No	Go to the next step.
2	INSPECT INSTRUMENT CLUSTER POWER SUPPLY FUSE  <ul style="list-style-type: none"> <li>• Is the instrument cluster ignition power supply fuse normal?</li> </ul>	Yes	Go to the next step.
		No	Inspect for a short to ground on circuit of blown fuse.  Repair or replace if necessary.  Install appropriate amperage fuse.
* 3	VERIFY WHETHER MALFUNCTION IS IN WIRING HARNESS (INSPECT FOR CONTINUITY BETWEEN INSTRUMENT CLUSTER POWER SUPPLY AND INSTRUMENT CLUSTER) OR INSTRUMENT CLUSTER  <ul style="list-style-type: none"> <li>• Turn ignition switch to ON position.</li> <li>• Measure voltage at instrument cluster connector (12-pin) terminal 1G.</li> <li>• Is the voltage <b>approx. 12 V</b>?</li> </ul>	Yes	Replace the instrument cluster (open circuit in instrument cluster).
		No	Inspect for open circuit between instrument cluster and ground.  Repair or replace if necessary.
4	CONFIRM DTC U1900 USING WDS OR EQUIVALENT  <ul style="list-style-type: none"> <li>• Retrieve DTCs from the PCM, ABS and instrument cluster.</li> <li>• Is DTC U1900 retrieved?</li> </ul>	Yes	Go to the next step.
		No	Inspect the instrument cluster. If normal, go to Step 6.
5	CONFIRM THE FOLLOWING PIDs USING WDS OR EQUIVALENT:	Yes	Replace the instrument cluster (open circuit in instrument cluster).

	<ul style="list-style-type: none"> <li>• ABS_MSG</li> <li>• PCM_MSG</li> <li>• EPS_MSG</li> <li>• TPM_MSG</li> <li>• Is "not present" message displayed on WDS or equivalent?</li> </ul>	No	<p>Inspect network communication for related system malfunction.</p> <p>Repair or replace if necessary.</p>
6	<p>CONFIRM DTC B2477 FOR INSTRUMENT CLUSTER USING WDS OR EQUIVALENT</p> <ul style="list-style-type: none"> <li>• Is DTC B2477 retrieved?</li> </ul>	Yes	Perform instrument cluster configuration.
		No	Replace the ABS HU/CM.

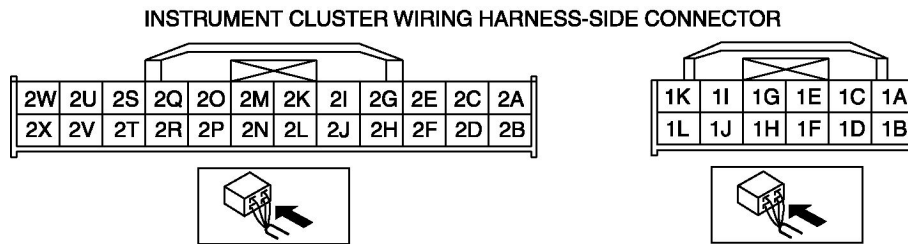

- When performing an asterisked (\*) troubleshooting inspection, slightly shake the wiring harness and connectors while performing the inspection to discover whether poor contact points are the cause of any intermittent malfunctions. If there is a problem, Verify that the connectors, terminals and wiring harness are connected correctly and undamaged.

## NO.2 ABS WARNING LIGHT DOES NOT ILLUMINATE WHEN IGNITION SWITCH TURNED TO ON POSITION

<b>2</b>	<b>ABS warning light does not illuminate when the ignition switch is turned to the ON position.</b>
<b>[TROUBLESHOOTING HINTS]</b>	
<ul style="list-style-type: none"> <li>• <b>Malfunction of instrument cluster or ABS HU/CM</b></li> </ul>	

Diagnostic procedure

STEP	INSPECTION	ACTION	
1	CONFIRM DTC U1900 USING WDS OR EQUIVALENT  <ul style="list-style-type: none"> <li>• Retrieve DTCs from the PCM, ABS and instrument cluster.</li> <li>• Is DTC U1900 retrieved?</li> </ul>	Yes	Go to the next step.
		No	Inspect the instrument cluster. If normal, go to the next step.
2	CONFIRM THE FOLLOWING PID <sub>s</sub> USING WDS OR EQUIVALENT:  <ul style="list-style-type: none"> <li>• ABS_MSG</li> <li>• PCM_MSG</li> <li>• EPS_MSG</li> <li>• TPM_MSG</li> <li>• Is "not present" message displayed on WDS or equivalent?</li> </ul>	Yes	Replace the instrument cluster (open circuit in instrument cluster).
		No	Inspect network communication for related system malfunction.  Repair or replace if necessary.

INSTRUMENT CLUSTER WIRING HARNESS-SIDE CONNECTOR

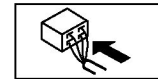
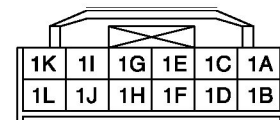
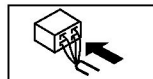
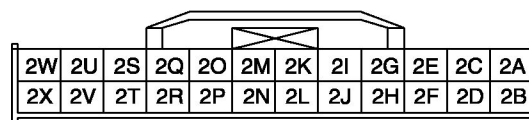



### NO.3 BRAKE SYSTEM WARNING LIGHT DOES NOT ILLUMINATE WHEN IGNITION SWITCH TURNED TO ON POSITION

<b>3</b>	<b>BRAKE system warning light does not illuminate when the ignition switch is turned to the ON position.</b>
<b>[TROUBLESHOOTING HINTS]</b>	
<ul style="list-style-type: none"> <li>• <b>Malfunction of instrument cluster or ABS HU/CM</b></li> </ul>	

Diagnostic procedure

STEP	INSPECTION		ACTION
1	CONFIRM DTC U1900 USING WDS OR EQUIVALENT  <ul style="list-style-type: none"> <li>• Retrieve DTCs from the PCM, ABS and instrument cluster.</li> <li>• Is DTC U1900 retrieved?</li> </ul>	Yes	Go to the next step.
		No	Inspect the instrument cluster. If normal, go to the next step.
2	CONFIRM THE FOLLOWING PIDs USING WDS OR EQUIVALENT:  <ul style="list-style-type: none"> <li>• ABS_MSG</li> <li>• PCM_MSG</li> <li>• EPS_MSG</li> <li>• TPM_MSG</li> <li>• Is "not present" message displayed on WDS or equivalent?</li> </ul>	Yes	Replace the instrument cluster (open circuit in instrument cluster).
		No	Inspect network communication for related system malfunction.  Repair or replace if necessary.

INSTRUMENT CLUSTER WIRING HARNESS-SIDE CONNECTOR

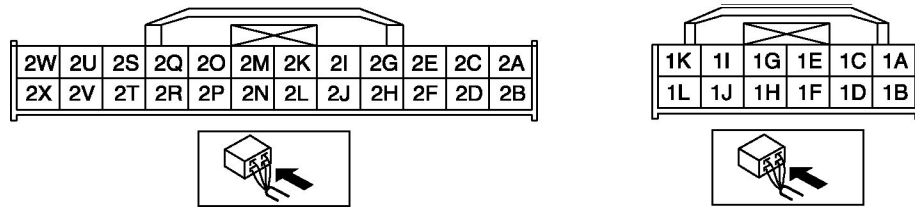

## NO.4 BOTH ABS WARNING LIGHT AND BRAKE SYSTEM WARNING LIGHT STAY ON 4 S OR MORE WHEN IGNITION SWITCH TURNED TO ON POSITION

<b>4</b>	<b>Both ABS warning light and BRAKE system warning light stay on 4 s or more when the ignition switch is turned to the ON position.</b>
<b>[TROUBLESHOOTING HINTS]</b>	
<ul style="list-style-type: none"> <li>• <b>ABS HU/CM detects ABS proportioning system malfunction.</b></li> <li>• <b>ABS HU/CM detects low voltage in power supply (ABS CM ingestion terminal Z voltage is below about 9 to 10 V).</b></li> <li>• <b>ABS HU/CM does not operate.</b></li> <li>• <b>Malfunction of communication network.</b></li> </ul>	

Diagnostic procedure

STEP	INSPECTION		ACTION
1	<b>INSPECT ABS HU/CM POWER SUPPLY FUSE</b> <ul style="list-style-type: none"> <li>• Is the ABS HU/CM ignition power supply fuse normal?</li> </ul>	Yes	Go to the next step.
		No	Inspect for a short to ground on circuit of blown fuse.  Repair or replace if necessary.  Install appropriate amperage fuse.
2	<b>INSPECT WIRING HARNESS BETWEEN ABS HU/CM AND DLC-2 FOR CONTINUITY AND SHORTS</b> <ul style="list-style-type: none"> <li>• Perform DTC inspection.</li> <li>• Is error message displayed regarding communication between ABS HU/CM and WDS or equivalent?</li> </ul>	Yes	If a communication error message is displayed even after inspecting according to procedure displayed on WDS or equivalent, go to step 10
		No	Go to the next step.
3	<b>INSPECT FOR DTCS IN ABS HU/CM</b> <ul style="list-style-type: none"> <li>• Have DTCs been stored in memory?</li> </ul>	Yes	Perform the applicable DTC inspection.
		No	Go to the next step.
4	<b>INSPECT PID/DATA IN ABS HU/CM</b>	Yes	Go to the next step.

## NO.5 ABS WARNING LIGHT STAYS ON 4 S OR MORE WHEN IGNITION SWITCH TURNED TO ON POSITION

<b>5</b>	<b>ABS warning light stays on 4 s or more when the ignition switch to the ON position.</b>
<b>[TROUBLESHOOTING HINTS]</b>	
<ul style="list-style-type: none"> <li><b>ABS HU/CM detects ABS system malfunction.</b></li> </ul>	

Diagnostic procedure

STEP	INSPECTION	ACTION	
1	<b>INSPECT WIRING HARNESS BETWEEN ABS HU/CM AND DLC-2 FOR CONTINUITY AND SHORTS</b> <ul style="list-style-type: none"> <li>Perform DTC inspection.</li> <li>Is error message displayed regarding communication between ABS HU/CM and WDS or equivalent?</li> </ul>	Yes	If the communication error message is displayed even after inspecting according to procedures displayed in the WDS or equivalent, go to Step 4.
		No	Go to the next step.
2	<b>INSPECT FOR DTCs IN ABS HU/CM</b> <ul style="list-style-type: none"> <li>Have DTCs been stored in memory?</li> </ul>	Yes	Perform the applicable DTC inspection.
		No	Go to the next step.
3	<b>INSPECT PID/DATA IN ABS HU/CM</b> <ul style="list-style-type: none"> <li>Inspect the following items using WDS or equivalent datalogger function. <ul style="list-style-type: none"> <li>ABS_LAMP (ABS warning light)</li> </ul> </li> <li>Is ABS_LAMP ON <b>4 s or more</b> after turning the ignition switch to the ON position?</li> </ul>	Yes	Replace the ABS HU/CM (open circuit or short to ground in ABS HU/CM).
		No	Inspect the instrument cluster.
* 4	<b>INSPECT WIRING HARNESS BETWEEN ABS HU/CM AND DLC-2 FOR CONTINUITY</b>  Disconnect the ABS HU/CM connector. <ul style="list-style-type: none"> <li>Is there continuity between connector terminal X and DLC-2?</li> </ul>	Yes	Go to the next step.
		No	Repair the wiring harness between the ABS HU/CM and DLC-2.
* 5	<b>INSPECT WIRING HARNESS BETWEEN ABS HU/CM AND DLC-2 FOR SHORT TO</b>	Yes	Repair the wiring harness between the ABS HU/CM and DLC-2.

## NO.6 BRAKE SYSTEM WARNING LIGHT STAYS ON 4 S OR MORE WHEN IGNITION SWITCH TURNED TO ON POSITION

<b>6</b>	<b>BRAKE system warning light stays on 4 s or more when the ignition switch is turned to the ON position. (Parking brake is released.)</b>
<b>[TROUBLESHOOTING HINTS]</b>	
<ul style="list-style-type: none"> <li>• <b>Malfunction of instrument cluster or ABS HU/CM</b></li> <li>• <b>Short to ground in circuit in parking brake switch and/or brake fluid level sensor</b></li> </ul>	

Diagnostic procedure

STEP	INSPECTION	ACTION	
1	INSPECT BRAKE FLUID LEVEL <ul style="list-style-type: none"> <li>• Is brake fluid level normal?</li> </ul>	Yes	Go to the next step.
		No	Add brake fluid.
* 2	INSPECT WIRING HARNESS BETWEEN ABS HU/CM AND DLC-2 FOR CONTINUITY AND SHORTS <ul style="list-style-type: none"> <li>• Inspect the following items using the WDS or equivalent datalogger function.               <ul style="list-style-type: none"> <li>▪ BRAKE_LMP (BRAKE system warning light)</li> </ul> </li> <li>• Is error message displayed regarding communication between ABS HU/CM and WDS or equivalent?</li> </ul>	Yes	If a communication error message is displayed even after inspecting according to procedures displayed on WDS or equivalent.  Go to next Step 6.
		No	Go to the next step.
3	INSPECT FOR DTCs IN ABS HU/CM <ul style="list-style-type: none"> <li>• Have DTCs been stored in memory?</li> </ul>	Yes	Perform the applicable DTC inspection.
		No	Go to the next step.
4	INSPECT PID/DATA IN ABS HU/CM <ul style="list-style-type: none"> <li>• Inspect (BRAKE system warning light) using the WDS or equivalent datalogger function.</li> <li>• Is BRAKE_LMP on <b>4 s or more</b> after the ignition switch is turned to the ON position?</li> </ul>	Yes	Replace the ABS HU/CM.
		No	Go to the next step.
5	VERIFY WHETHER MALFUNCTION IS IN PARKING BRAKE SWITCH OR BRAKE FLUID LEVEL SENSOR, OR IN SOME OTHER PART	Yes	Replace the parking brake switch and/or brake fluid level sensor (Short with some internal part).

**NO.7 ANY OF THE FOLLOWING LIGHTS DO NOT ILLUMINATE WHEN IGNITION SWITCH TURNED TO ON POSITION: (ABS WARNING LIGHT, BRAKE SYSTEM WARNING LIGHT, DSC INDICATOR LIGHT AND/OR DSC OFF LIGHT)**

<b>7</b>	<p><b>Any of the following lights do not illuminate when the ignition switch is turned to the on position: (ABS warning light, BRAKE system warning light, DSC indicator light and/or DSC OFF light).</b></p> <p><b>[TROUBLESHOOTING HINTS]</b></p> <ul style="list-style-type: none"> <li>• <b>Inspect each light in the instrument cluster for malfunction</b></li> <li>• <b>Poor connection at DSC HU/CM connector</b></li> </ul>
----------	--

Diagnostic procedure

STEP	INSPECTION		ACTION
1	<p>INSPECT FOR DTCS IN DSC HU/CM</p> <ul style="list-style-type: none"> <li>• Inspect the DTC for the DSC ON-BOARD DIAGNOSTIC SYSTEM.</li> <li>• Have DTCs been stored in memory?</li> </ul>	Yes	Perform the applicable DTC inspection.
		No	Go to the next step.
2	<p>INSPECT WHETHER MALFUNCTION IS IN INSTRUMENT CLUSTER SYSTEM OR OTHER SYSTEM</p> <ul style="list-style-type: none"> <li>• Do other warning and indicator lights illuminate when the ignition switch is turned to the ON position?</li> </ul>	Yes	Go to the next step.
		No	Inspect or repair the instrument cluster (power supply system, ground system).
3	<p>VERIFY THAT DSC HU/CM CONNECTOR IS CONNECTED</p> <ul style="list-style-type: none"> <li>• Is the DSC HU/CM securely connected?</li> </ul>	Yes	Go to the next step.
		No	Connect the DSC HU/CM connector securely, then go to the next step.
4	<p>VERIFY THAT DSC HU/CM CONNECTOR TERMINAL OR RELATED CONNECTOR TERMINALS ARE CONNECTED</p> <ul style="list-style-type: none"> <li>• Are DSC HU/CM connector terminal, instrument cluster connector terminal, or related connector terminals securely connected?</li> </ul>	Yes	Replace the DSC HU/CM.
		No	Securely connect DSC HU/CM connector terminal and related connector terminals.

**NO.8 ANY OF THE FOLLOWING LIGHTS REMAIN ON: (ABS WARNING LIGHT, BRAKE SYSTEM WARNING LIGHT, DSC INDICATOR LIGHT AND/OR DSC OFF LIGHT)**

<b>8</b>	<p><b>Any of the following lights remain on: (ABS warning light, BRAKE system warning light, DSC indicator light and/or DSC OFF light)</b></p> <p><b>[TROUBLESHOOTING HINTS]</b></p> <ul style="list-style-type: none"> <li>• <b>Brake fluid amount is low</b></li> <li>• <b>Parking brake does not release</b></li> <li>• <b>No connection at DSC HU/CM connector</b></li> </ul> <p><b>(When DSC HU/CM connector is disconnected, ABS warning light and BRAKE system warning light illuminate)</b></p> <ul style="list-style-type: none"> <li>• <b>DSC HU/CM detected malfunction (Input and output device malfunction)</b></li> <li>• <b>DSC HU/CM detects low voltage in power supply</b></li> <li>• <b>DSC HU/CM ground malfunction</b></li> </ul> <p><b>(When DSC HU/CM ground is not securely connected, ABS warning light and BRAKE system warning light illuminate but diagnostic trouble code does not displayed)</b></p> <ul style="list-style-type: none"> <li>• <b>DSC HU/CM does not operate (DSC HU/CM malfunction)</b></li> </ul>
----------	--

Diagnostic procedure

STEP	INSPECTION	ACTION	
1	<p>INSPECT BRAKE FLUID AMOUNT AND VERIFY THAT PARKING BRAKE RELEASES</p> <ul style="list-style-type: none"> <li>• Is the brake fluid amount normal?</li> <li>• Is the parking brake lever released?</li> </ul>	Yes	Go to the next step.
		No	Add brake fluid or release parking brake lever.
2	<p>INSPECT DTCS IN DSC HU/CM</p> <ul style="list-style-type: none"> <li>• Inspect the DTC for the DSC ON-BOARD DIAGNOSTIC SYSTEM.</li> <li>• Have DTCs been stored in memory?</li> </ul>	Yes	Perform inspection using appropriate DTC.
		No	Go to the next step.
3	<p>INSPECT WHETHER MALFUNCTION IS IN CONTROL MODULE CONNECTOR, TERMINAL OR OTHER</p> <ul style="list-style-type: none"> <li>• Do ABS warning light and BRAKE system warning light go off after 4 s when the ignition switch is turned to the ON position?</li> </ul>	Yes	<p>Temporary poor connection in control module connector.</p> <p>Inspect DSC HU/CM connector, then go to Step 6.</p> <p>Inspect DSC HU/CM connector terminal, then go to Step 7.</p>

**NO.9 THERE IS A MALFUNCTION IN THE SYSTEM EVEN THOUGH ABS WARNING LIGHT, BRAKE SYSTEM WARNING LIGHT, DSC INDICATOR LIGHT AND DSC OFF LIGHT DO NOT ILLUMINATE**

<b>9</b>	<p><b>There is a malfunction in the system even though the ABS warning light, BRAKE system warning light, DSC indicator light and DSC OFF light do not illuminate.</b></p> <p><b>[TROUBLESHOOTING HINTS]</b></p> <ul style="list-style-type: none"> <li>• <b>There is a mechanical malfunction in system</b></li> </ul>
----------	---

Diagnostic procedure

STEP	INSPECTION		ACTION
1	<p>INSPECT DSC HU/CM FOR DTCs</p> <ul style="list-style-type: none"> <li>• Inspect the DTC for the DSC ON-BOARD DIAGNOSTIC SYSTEM.</li> <li>• Have DTCs been stored in memory?</li> </ul>	Yes	Perform the applicable DTC inspection.
		No	Go to the next step.
2	<p>INSPECT DSC SYSTEM</p> <ul style="list-style-type: none"> <li>• Perform DSC system inspection.</li> <li>• Is the system normal?</li> </ul>	Yes	Inspect the conventional brake system.
		No	Repair or replace any malfunctioning part.

**NO.10 ABS OR TCS(\*1) OPERATES FREQUENTLY/TCS DOES NOT WORK CORRECTLY(\*1): DSC SYSTEM FUNCTION CONTAINS TRACTION CONTROL FUNCTION, DSC INDICATOR LIGHT GOES ON AND OFF WHILE DSC IS OPERATING**

10	<p><b>ABS or TCS (*1) operates frequently./TCS does not work correctly.</b></p> <p><b>(*1): DSC system function contains traction control function; DSC indicator light goes on and off while DSC is operating.</b></p>
<p><b>[TROUBLESHOOTING HINTS]</b></p> <ul style="list-style-type: none"> <li>• <b>There is a difference in size or air pressure between the front and rear tires</b></li> <li>• <b>Incorrect ABS wheel-speed signal is input to DSC HU/CM</b></li> <li>• <b>There is a malfunction in the engine control system (TCS malfunction)</b></li> </ul>	

Diagnostic procedure

STEP	INSPECTION	ACTION	
1	<p><b>INSPECT DTCS IN DSC HU/CM</b></p> <ul style="list-style-type: none"> <li>• Inspect the DTC for the DSC ON-BOARD DIAGNOSTIC SYSTEM.</li> <li>• Have DTCs been stored in memory?</li> </ul>	Yes	Perform the applicable DTC inspection.
		No	Go to the next step.
2	<p><b>INSPECT TIRE SIZE AND AIR PRESSURE</b></p> <ul style="list-style-type: none"> <li>• Inspect the tire size and the air pressure.</li> <li>• Are size and air pressure as specified?</li> </ul>	Yes	Go to the next step.
		No	Replace with specified tires and adjust tire air pressure.
3	<p><b>INSPECT ABS WHEEL-SPEED SENSOR OUTPUT</b></p>	Yes	Find that malfunctioning part according to "INTERMITTENT CONCERN TROUBLESHOOTING".



**NO.11 DSC<sup>&ast;2</sup> OPERATES FREQUENTLY/DSC DOES NOT WORK CORRECTLY<sup>&ast;2</sup>: DSC INDICATOR LIGHT GOES ON AND OFF WHILE DSC IS OPERATING**

11	<p><b>DSC (*2) operates frequently. /DSC does not work correctly.</b></p> <p><b>(*2): DSC indicator light goes on and off while DSC is operating.</b></p>
<p><b>[TROUBLESHOOTING HINTS]</b></p> <ul style="list-style-type: none"> <li>• <b>DSC HU/CM detected malfunction (input and output device malfunction)</b></li> <li>• <b>Poor installation of yaw rate sensor, lateral-G sensor and/or steering angle sensor</b></li> </ul> <p><b>(If any of the above sensors are poorly installed, DSC may operate intermittently)</b></p> <ul style="list-style-type: none"> <li>• <b>When replacing the DSC HU/CM, yaw rate sensor, lateral-G sensor or steering angle sensor, initialization is not performed.</b></li> </ul> <p><b>(If initialization is not performed correctly, DSC may not work correctly)</b></p>	

Diagnostic procedure

STEP	INSPECTION	ACTION	
1	<p><b>INSPECT DSC HU/CM FOR DTCs</b></p> <ul style="list-style-type: none"> <li>• Inspect the DTC for the DSC ON-BOARD DIAGNOSTIC SYSTEM.</li> <li>• Have DTCs been recorded in memory?</li> </ul>	Yes	Perform the applicable DTC inspection.
		No	Go to the next step.
2	<p><b>VERIFY THAT EACH SENSOR IS INSTALLED</b></p> <ul style="list-style-type: none"> <li>• Are the combined sensor and steering angle sensor securely installed?</li> </ul>	Yes	Go to the next step.
		No	Install sensor securely.
*3	<p><b>VERIFY THAT EACH SENSOR IS INITIALIZED</b></p> <ul style="list-style-type: none"> <li>• Was initialization performed after replacement of DSC HU/CM, combined sensor or steering angle sensor?</li> </ul>	Yes	Find malfunctioning part according to "INTERMITTENT CONCERN TROUBLESHOOTING."
		No	Perform initialization procedure.

# GENERAL PROCEDURES BRAKES

## Wheel and Tire Installation

1. When installing the wheels and tires, tighten the wheel nuts in a criss-cross pattern to the following tightening torque.

### Tightening torque

- 88—118 N·m {9.0—12.0 Kgf·m, 65.0—87.0 ft·lbf}

## Brake Lines Disconnection

1. If any brake line has been disconnected anytime during the procedures, add brake fluid, bleed the brakes, and inspect for leakage after the procedure has been completed.

### CAUTION:

- Brake fluid will damage painted surfaces. Be careful not to spill any on painted surfaces. If it is spilled, wipe it off immediately.

## Brake Pipe Flare Nut Tightening

1. Tighten the brake pipe flare nut using the **SST** (49 0259 770B) or any commercially available flare nut wrench.

## Connector Disconnection

1. Disconnect the negative battery cable before doing any work that requires handling of connectors.

## ABS/DSC Related Parts

1. Make sure that there are no DTCs in the ABS/DSC memory after working on ABS/DSC related parts. If there are any codes in the memory, clear them.

## DSC Related Part Sensor Initialization Procedure

### WARNING:

- If the initialization procedure is not completed, the DSC will not operate properly and it might cause an unexpected accident. Therefore, when replacing or removing the following parts, make sure to perform the initialization procedure to insure proper DSC operation.
1. When replacing or removing the following parts, perform the initialization procedure.
    - DSC HU/CM
    - Combined sensor
    - Steering angle sensor

# TECHNICAL DATA

## BRAKES

Item		Specification	
<b>CONVENTIONAL BRAKE SYSTEM</b>			
Brake pedal	Pedal height (reference value)	(mm {in})	175 {6.89}
	Pedal play	(mm {in})	2—5 {0.08—0.19}
	Pedal-to-floor clearance (Brake pedal when depressed at 147 N {15.0 kgf, 33 lbf})	(mm {in})	98.6 {3.88} or more
Power brake unit	Fluid pressure when pedal depressed at 200 N {20.4 kgf, 44.9 lbf}	At 0 kPa {0 mmHg, 0 inHg}	606 {6.18, 87.9} or more
	(kPa {kgf/cm <sup>2</sup> , psi})	At 66.7 kPa {500 mmHg, 19.7 inHg}	7,310 {74.54, 1,060} or more
Front brake (disc)	Minimum disc pad thickness	(mm {in})	2.0 {0.079}
	Minimum disc plate thickness	(mm {in})	22 {0.87}
	Disc plate runout limit	(mm {in})	0.05 {0.002}
Rear brake (disc)	Minimum disc pad thickness	(mm {in})	2.0 {0.079}
	Minimum disc plate thickness	(mm {in})	16 {0.63}
	Disc plate runout limit	(mm {in})	0.05 {0.002}
Brake fluid	Type	SAE J1703, FMVSS 116 DOT-3	
<b>PARKING BRAKE SYSTEM</b>			
Parking brake lever	Lever stroke when pulled with 98 N {10 kgf, 22 lbf} at point 50 mm {1.97 in} from the end of the parking brake lever	(notches)	1—3