

BODY

14-A. WINDSHIELD GLASS	14 : 1
14-A-1. Removing of Windshield Glass	14 : 1
14-A-2. Installing of Windshield Glass	14 : 2
14-B. REAR WINDOW	14 : 4
14-C. FRONT DOOR	14 : 5
14-C-1. Disassembling of Front Door	14 : 5
14-C-2. Assembling of Front Door	14 : 5
14-C-3. Adjusting of Front Door	14 : 6
14-D. REAR DOOR	14 : 6
14-D-1. Disassembling of Rear Door	14 : 6
14-D-2. Assembling of Rear Door	14 : 6
14-E. TOP CEILING	14 : 7
14-E-1. Removing of Top Ceiling	14 : 7
14-E-2. Installing of Top Ceiling	14 : 7
14-F. REAR SIDE WINDOW (COUPÉ).....	14 : 7
14-F-1. Removing of Rear Side Window	14 : 7
14-F-2. Installing of Rear Side Window	14 : 8

14-A. WINDSHIELD GLASS

Windshield glass of the type which is bonded on is installed: the wind shield glass is bonded to the body in order to reduce the noise level of the wind blowing against the windshield glass during driving, obtain tight sealing, enhance the body strength and increase the safety at the time of crash.

Fig. 14-1 shows the structure.

The windshield glass is bonded to the body with a sealant, and the dam prevents the sealant from being forced towards the interior of the vehicle when the window glass is being installed.

The windshield glass is positioned to the body with 3 to 4 spacers, and the mould is fitted into the clips attached to the body.

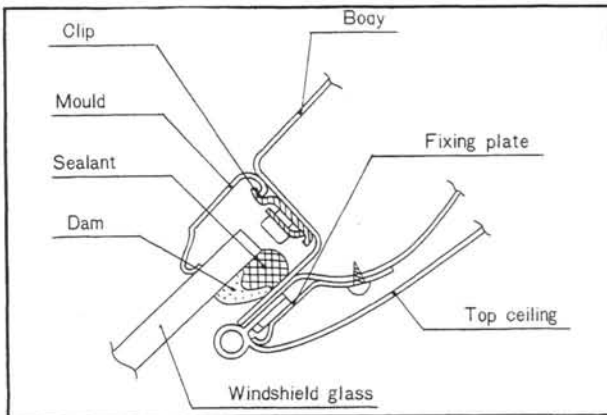

Fig. 14-1 Structure of windshield

Use the following **window tool set** (49 0305 870) as shown in Fig. 14-2 to remove and install the windshield glass.

14-A-1. Removing of Windshield Glass

1. Remove the interior mirror and also the right and left front pillar trims from the interior of the vehicle.
2. Remove the wiper arms.
3. Using the **mould remover** (49 0305 871), remove the mould in the manner shown in Fig. 14-3.
4. Remove the clips.

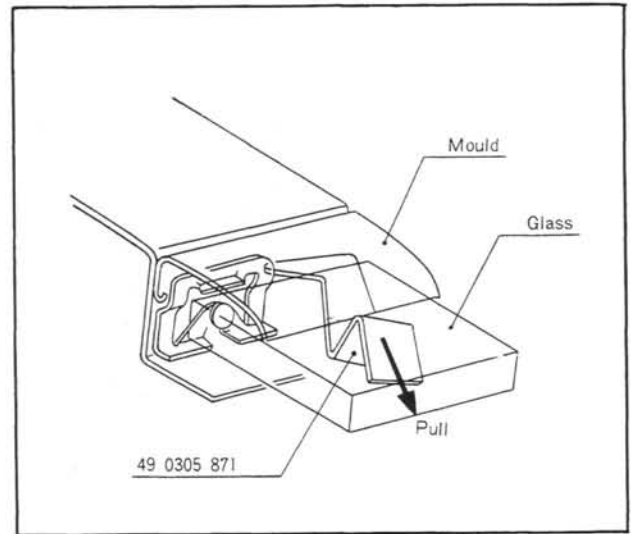

Fig. 14-3 Removing of mould

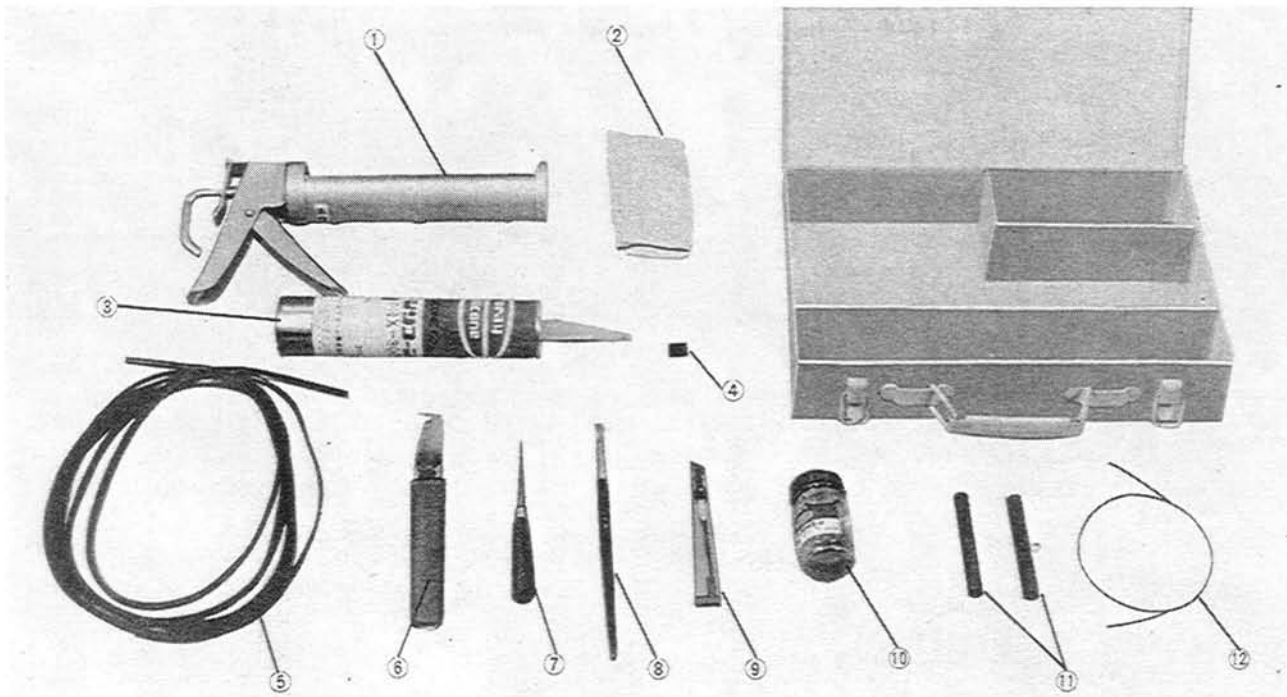

Fig. 14-2 Window tool set

- | | | |
|-----------------------------------|--------------------------------|-----------------------------------|
| 1. Sealant gun (49 0305 872) | 5. Dam | 9. Cutting knife |
| 2. Guaze | 6. Mould remover (49 0305 871) | 10. Primer (Part No. 0305 77 738) |
| 3. Sealant (Part No. 0305 77 739) | 7. Needle (eyeleteer) | 11. Bar |
| 4. Spacer | 8. Brush | 12. Piano wire (0.5 mm diameter) |

5. Pierce the window sealant with a needle (eyeleteer). Pass a piano wire of approximately 500 mm (20 in) long, through the hole, and wrap each end of the wire around a small bar.



Fig. 14-4 Piercing of piano wire

6. Cut the sealant off along the entire circumference of the glass by two persons (one inside the vehicle and the other outside it) each pulling one of the bars as if they were using a saw.

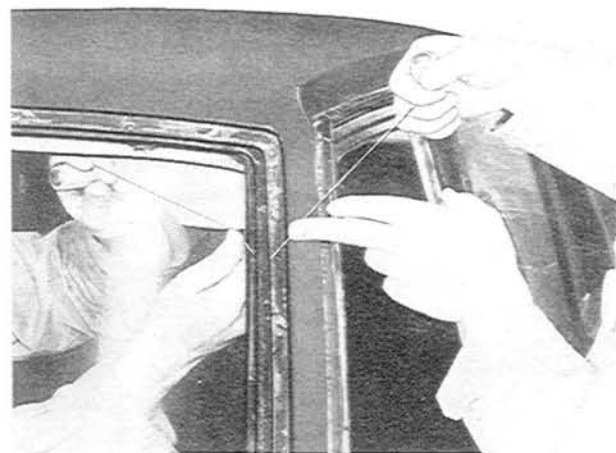

Fig. 14-5 Cutting of sealant

Note:

(a) When cutting the sealant with a piano wire, cut it along the border between the window glass and the sealant.

(b) The piano wire is liable to snap if only a certain section is constantly used and becomes hot.

Therefore, when cutting the sealant ensure that the piano wire is kept cool (it should be cooled slowly) or the section of the wire being used is constantly rotated.

(c) When cutting the sealant off, pay special attention so that the top ceiling, painted surfaces, etc. are not damaged.

7. Remove the window glass from the body. The removal of the window glass shown in Fig. 14-6 should be performed by two persons.

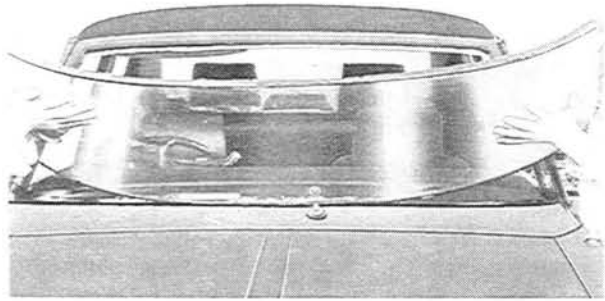

Fig. 14-6 Removing of windshield glass

14-A-2. Installing of Windshield Glass

1. Using a cutting knife, cut the sealant off smoothly so that approximately 1 to 2 mm (0.04 to 0.08 in) of sealant remains along the entire circumference of the windshield framework.



Fig. 14-7 Cutting of sealant

If the thickness of sealant left along the circumference of the window framework is too small, first, clean with a solvent to remove any grease.

Then, apply primer with a brush and leave it to dry for 20 to 30 minutes.

Then, apply sealant until a thickness of 1 to 2 mm (0.04 to 0.08 in) is obtained.



Fig. 14-8 Applying of primer

2. Using a solvent, wipe the entire edges of the window glass to a width of approximately 50 mm (2.0 in) from the edge and also the entire circumference of the body on which the glass is to be bonded to remove any grease.

Then, bond the dam with bonding agent parallel to the edge of the window glass at a position 7 mm (0.028 in) away from it. Bond the dam in the direction shown in Fig. 14-9.

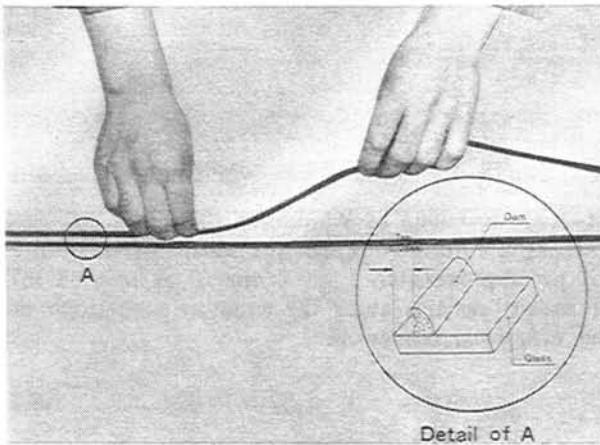

Fig. 14-9 Bonding of dam

Note: Securely bond the dam so that it is straight and will not come apart.

3. Apply primer on the entire circumferences of the bonding areas of the window glass and the body with gauze (for the former) and a brush (for the latter), and leave them to dry for 20 to 30 minutes. (See Fig. 14-8)

Note:

(a) Apply as thin a sealant coating as possible to the window glass.

(b) Don't allow any dust, water, oil, etc. to get on the coating surface and also don't touch the coating with hand.

(c) If the window glass which was removed is to be reused, remove the sealant adhering to the glass to some extent with a cutting knife.

Then, remove the remaining sealant with a cleaning solvent and wipe it clean with gauze.

4. Bond each spacer to the body with bonding agent. Fig. 14-10 shows the directions and positions of each spacer.

There are two kinds of spacer, identified by color as shown below.

Part No.	Name of Part	Color
0305 70 448	Spacer	Gray
0305 70 447A	Spacer	Black

Although a spacer is bonded on both the right and the left hand sides of the windshield glass in Fig. 14-10, a spacer on only one side of the glass should be sufficient.

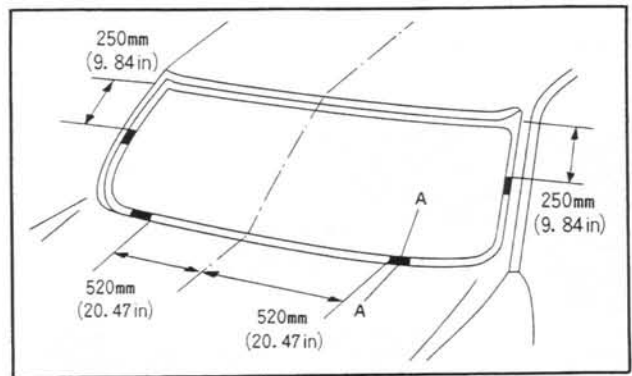

Fig. 14-10 Positions of spacers

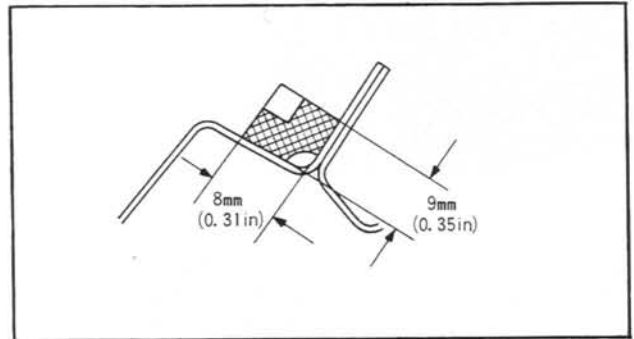

Fig. 14-11 A-A section of Fig. 14-10

5. Insert each clip to the clip insertion portion in the manner shown in Fig. 14-12.

If any clip happens to be loose after it has been inserted, replace with a new clip.

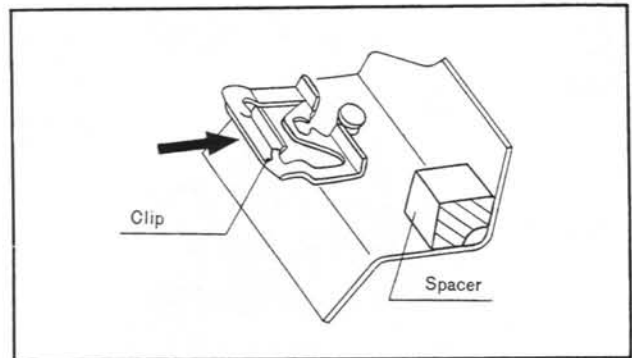

Fig. 14-12 Inserting of clip

6. After the primer is dry, apply the sealant so that

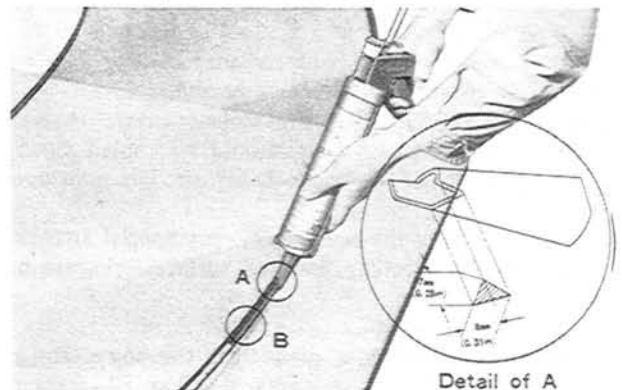

Fig. 14-13 Applying of sealant

it is 8 mm (0.31 in) high along the entire circumference of the window glass with the **sealant gun** (49 0305 872) fitted with a sealant cartridge (see Fig. 14-13). If the sealant comes apart from the painted surface on the body side, use the remainder of the sealant for rectification.

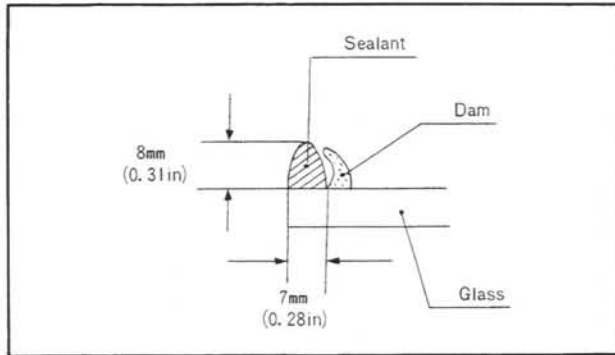

Fig. 14-14 Detail B of Fig. 14-13

Note:

- (a) Shape the nozzle of the sealant cartridge with a cutting knife as shown in Fig. 14-13. Then, break the film of the sealant with a piece of wire and it is ready for application.
- (b) If the application is unsatisfactory, rectify it with a wooden spatula.
- (c) If any sealant adheres to your hand, it should be removed immediately.

7. Install the window glass to the body. Adjust the step between the window glass and the body to be 5.8 mm (0.23 in).

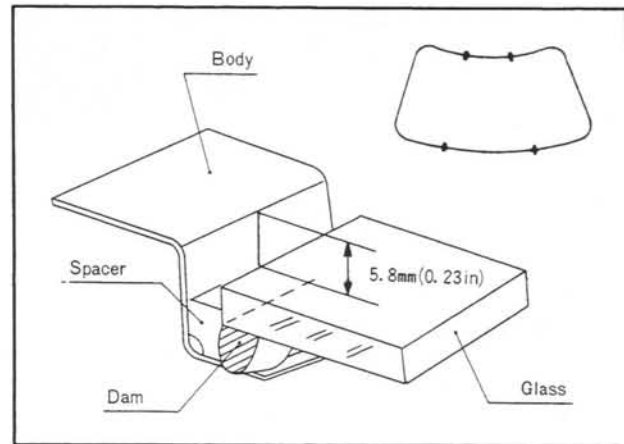

Fig. 14-15 Adjusting of step

Note:

- (a) After placing the window glass on the inner side of the spacer, push the glass with the hand and check the step at the four positions shown in Fig. 14-15.
- (b) If possible, do not apply any force to the window glass until the sealant has hardened.

Time required for the sealant to harden after it is applied
 Summer (20°C, 68°F)..... 5 hours
 Winter (5°C, 41°F).....24 hours

- 8. If any sealant has been forced out or is found to be lacking, rectify such portions with a wooden spatula.
- 9. After checking to ensure that there are no water leakages, install the mould, interior mirror, front pillar trim, etc.

Precautions:

- 1. If any water leakage is found after the sealant has hardened, use repairing agent.
- 2. Keep the door windows open until the sealant has hardened to some extent.
 If the door windows are kept tightly closed, the interior atmospheric pressure would suddenly change when the doors are opened and closed. This could cause vacant spaces to develop in the unhardened sealant and deteriorate the air-tightness and bonding properties of the sealant.
- 3. The time required before the vehicle can be driven after the sealant has been applied is approximately 5 hours in summer (20°C, 68°F) or 24 hours in winter (5°C, 41°F) if the sealant is left in open weather for drying.
- 4. If the vehicle is to be repainted, remove all the sealant from the body and then after baking the paint on, apply the sealant so that it is 10 mm (0.4 in) high.
 Never apply air setting paint to the surface on which the sealant is to be applied, because the air setting painting method would have problems in weatherproofness and its bonding properties between the paint layer and the sheet metal and between the paint layer and the primer.

14-B. REAR WINDOW

The removal and installation of the rear window glass can be made in the same way as those of the windshield glass.

But care should be taken to the following points:

- 1. In the case of a vehicle equipped with a rear window with printed hot lines, perform the work of disconnection and connection of the relevant wiring.
- 2. The step between the rear window glass and the body should be adjusted to be 7.8 mm (0.31 in).

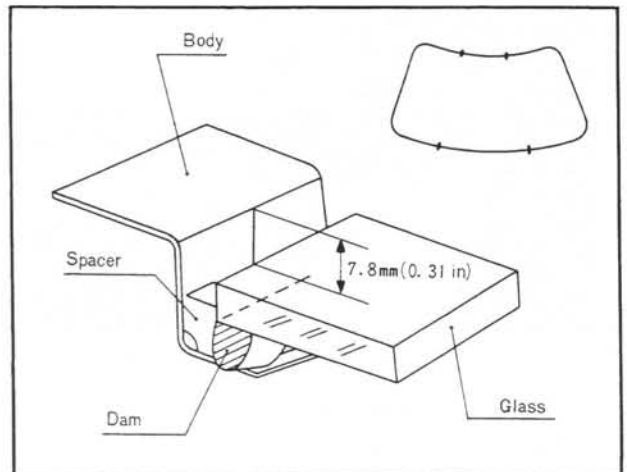

Fig. 14-16 Adjusting of step

3. The directions and positions of each spacer to be bonded are shown in Fig. 14-17.

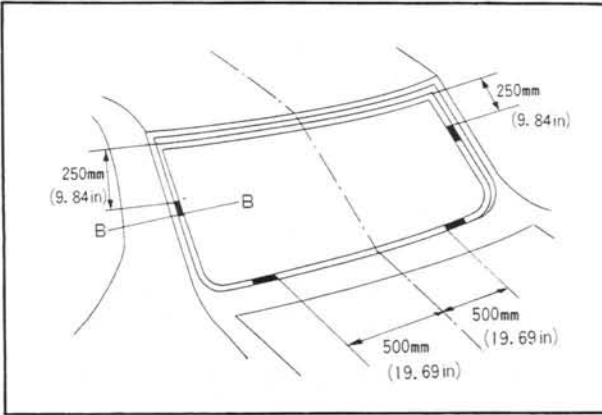

Fig. 14-17 Positions of spacers

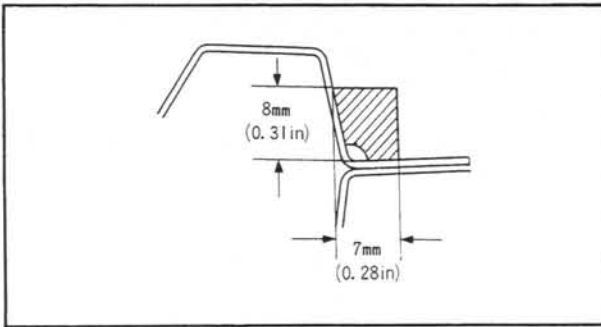

Fig. 14-18 B-B section of Fig. 14-17

14-C. FRONT DOOR

14-C-1. Disassembling of Front Door

1. Remove the inner lock knob.
2. Remove the arm rest.
3. Remove the inner handle cover.
4. Remove the pad of the regulator handle and remove the regulator handle and escutcheon by loosening the attaching bolt.

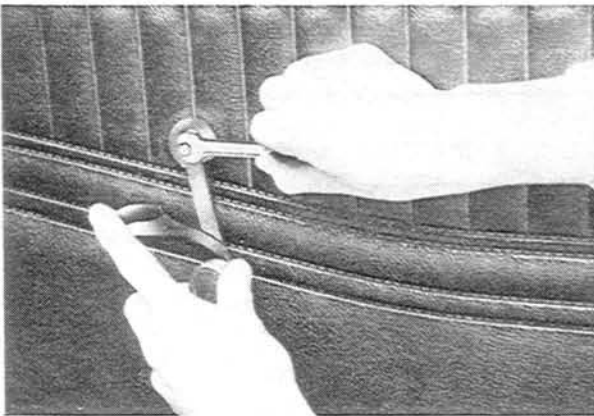

Fig. 14-19 Removing of regulator handle

5. Remove the door trim board.
6. Remove the inside screens (vinyl), which are installed to prevent water leakages.
7. Remove the outer weatherstrip from the door body.

8. Remove the door window glass. With the window glass lowered to half-opened position, it can be easily taken out.



Fig. 14-20 Removing of glass

9. Remove the outer handle.
10. Pull out the set spring and remove the key cylinder

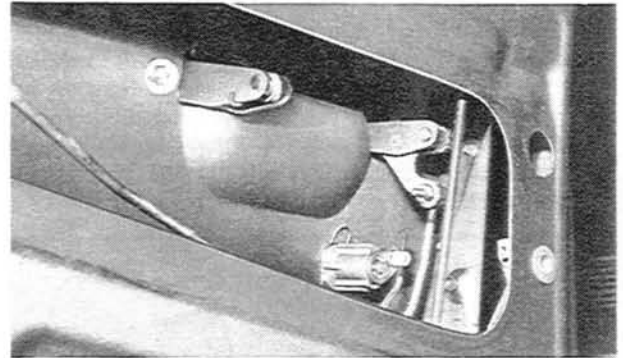

Fig. 14-21 Removing of key cylinder

11. Remove the door lock complete.
12. Remove the window regulator.

14-C-2. Assembling of Front Door

1. Install the outer handle.
2. Install the key cylinder and fit the set spring to the key cylinder.
3. Install the door lock complete.

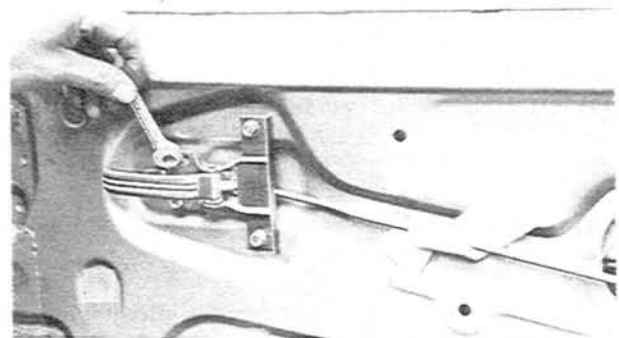

Fig. 14-22 Installing of door lock complete

4. Connect the actuating rod after adjusting the free play of the outer handle by the nylon bush to be within 1.5 to 3.0 mm (0.06 to 0.12 in).
5. Install the glass guides and tighten them with bolts.
6. Install the door run channel in the door sash.
7. Install the window regulator and temporarily tighten it.

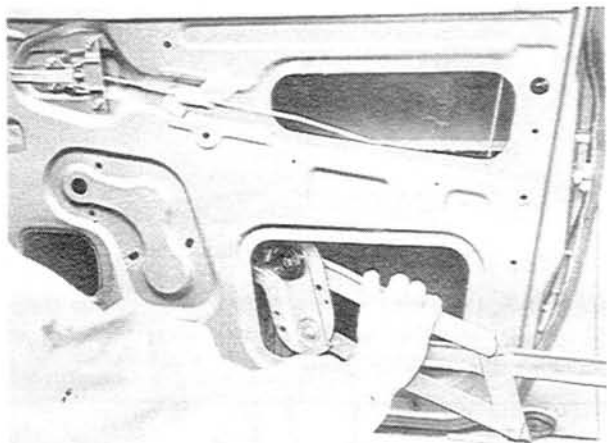

Fig. 14-23 Installing of window regulator

8. Install the door window glass, and securely tighten the window regulator while adjusting the alignment between the window glass and the door sash.
9. To prevent water leakage, apply a solid sealing agent on the heads of the bolts attaching the window regulator.
10. Paste the inside screens.
11. Install the outer weatherstrip to the door body.
12. Install the door trim board and inner lock knob.
13. Install the inner handle cover.
14. Install the regulator handle.
15. Install the arm rest.

14-C-3. Adjusting of Front Door

The doors are adjustable at the hinge mountings on the door and the body. The door striker is also adjustable. These adjustments are adequate to obtain proper door alignment and adjustment. The hinge attaching holes on the door pillars are larger than the bolts, permitting adjustment in either direction.

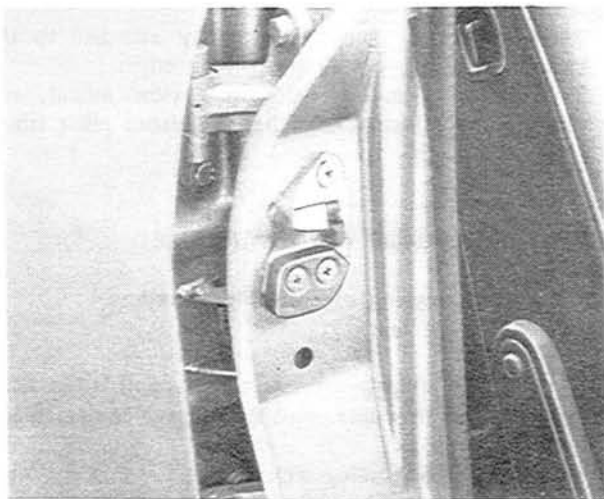

Fig. 14-24 Door striker

14-D. REAR DOOR

14-D-1. Disassembling of Rear Door

1. Remove the inner lock knob.
2. Remove the arm rest.
3. Remove the inner handle cover.
4. Remove the pad of the regulator handle and remove the regulator handle and escutcheon by loosening the attaching bolt.
5. Remove the door trim board.
6. Remove the inside screens (vinyl), which are install to prevent water leakages.
7. Remove the outer weatherstrip from the door body.
8. Remove the center sash, and slide off the quarter window glass with the weatherstrip.

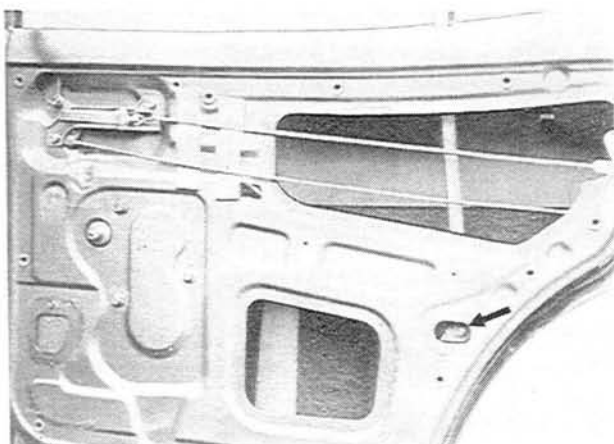

Fig. 14-25 Removing of center sash

9. Remove the door window glass. With the window glass lowered to half-opened position, it can be easily taken out.



Fig. 14-26 Removing of glass

10. Remove the outer handle.
11. Remove the door lock complete.
12. Remove the window regulator.

14-D-2. Assembling of Rear Door

1. Install the outer handle.
2. Install the door lock complete.
3. Connect the actuating rod after adjusting the free

play of the outer handle by the nylon bush to be within 1.5 to 3.0 mm (0.06 to 0.12 in).

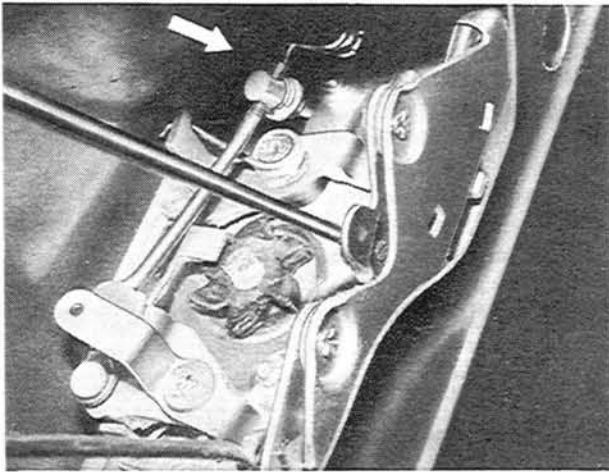

Fig. 14-27 Connecting of actuating rod

4. Install the window regulator.
5. Install the door window glass.
6. Install the center sash and temporarily tighten it.
7. Install the glass run channel.
8. Install the quarter window.
9. Securely tighten the center sash while adjusting the alignment between the window glass and the door sash.
10. Install the outer weatherstrip.
11. Paste the inside screens.
12. To prevent water leakage, apply a solid sealing agent on the heads of the bolts attaching the window regulator.
13. Install the door trim board and inner lock knob.
14. Install the regulator handle.
15. Install the arm rest.

14-E. TOP CEILING

14-E-1. Removing of Top Ceiling

1. Remove the rear view mirror, sun visors, interior lamps, assist handles, etc.
2. Remove the front pillar trims and rear package tray trim.
3. Strip off the seaming welts from the body flange.
4. Strip off the front and rear polyethylene plates from the inserting point of the body.
5. remove the listing wire and top ceiling.

14-E-2. Installing of Top Ceiling

1. Affix the head linings (top insulations) onto the body ceiling with adhesive cement.
2. Heat up the top ceiling to a temperature of 30°C to 50°C (86° F to 122° F).
3. Insert both ends of each of the listing wires to their proper positions in successive order beginning from the rear as shown in Fig. 14-28. When doing so, be careful that the wires do not swing down.
4. Insert the front and rear polyethylene plates of the top ceiling to the inserting point of the body.



Fig. 14-28 Installing of listing wire

Note: When inserting the top ceiling, if the guide made of plastic plate is used, you can insert it without touching the weaving point.

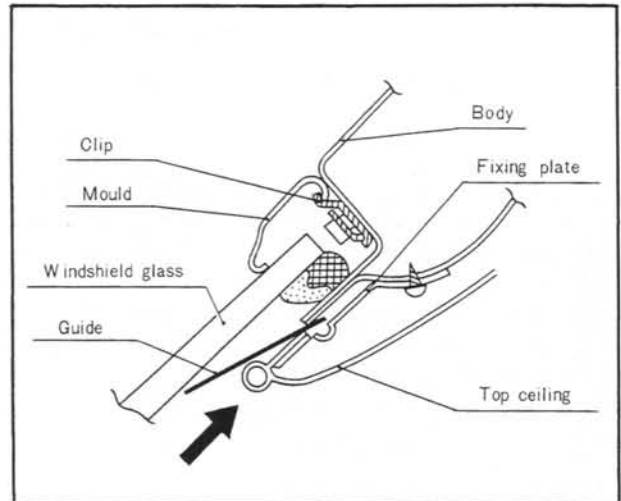

Fig. 14-29 Inserting of top ceiling

5. Apply neoprene adhesive cement to the outside of the body flange.
6. After one or two minutes, pull the top ceiling from both side to avoid any slackening and glue both side onto the body flange.
7. After the top ceiling is properly attached to the body flange, clip off all protruding edges.
8. Install the seaming welts, rear view mirror, sun visors, interior lamps, assist handles, front pillar trims, rear package tray trim, etc.

14-F. REAR SIDE WINDOW (COUPÉ)

14-F-1. Removing of Rear Side Window

1. Remove the seat.

Note: When removing the seat back, pull it out after removing the two nuts from the luggage compartment.

2. Remove the seaming welt covers.
3. Remove the package tray trim upper as shown in Fig. 14-30.

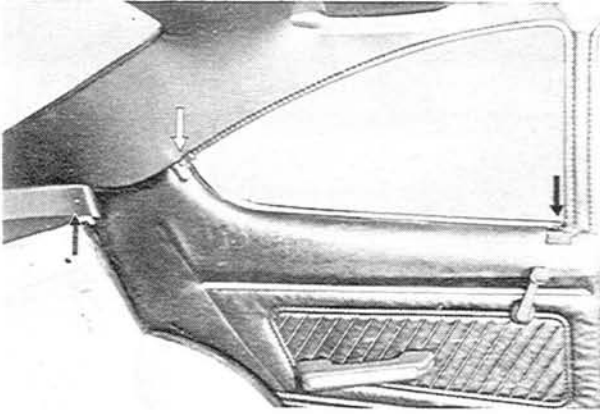

Fig. 14-30 Removing of seaming welt cover

4. Remove the pad of the regulator handle and remove the regulator handle and escutcheon by loosening the attaching bolt.
5. Remove the arm rest.
6. Remove the door trim board.
7. Remove the inside screens (vinyl), which are installed to prevent water leakages.
8. Remove the glass guide.

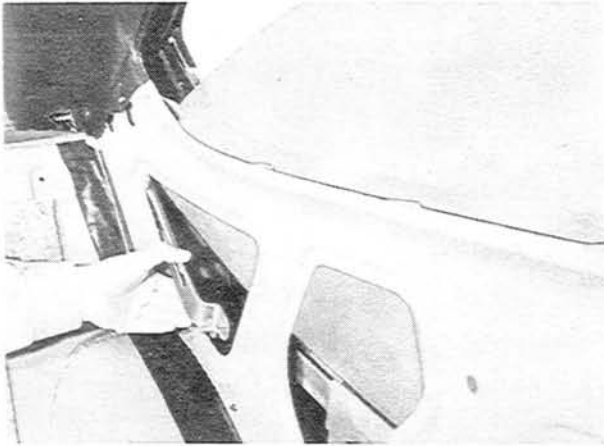

Fig. 14-31 Removing of glass guide

9. Remove the window glass. With the window glass lowered to half-opened position, it can be easily taken out.

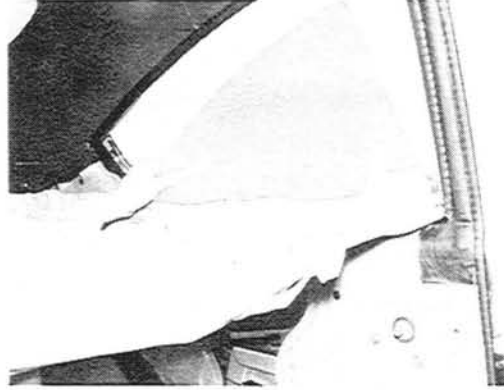

Fig. 14-32 Removing of window glass

10. Remove the regulator.

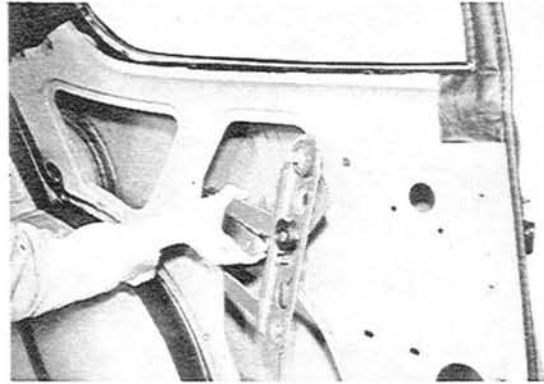

Fig. 14-33 Removing of regulator

11. Remove the outer weatherstrip.

14-F-2. Installing of Rear Side Window

Carry out the removing operations in the reverse order.

SPECIAL TOOLS

49 0305 871	Mould remover
49 0305 872	Sealant gun
49 0305 870	Window tool set (included above two tools)