

45U0JX-053

**Installation note****Transmission**

1. Tilt the engine by pushing up on the front of the oil pan with a wooden block and a transmission jack.
2. Support the transmission with a transmission jack.
3. Raise the transmission into place and install and tighten the installation bolts.

**Tightening torque:**

64—89 N·m {6.5—9.1 kgf·m, 48—65 ft·lbf}

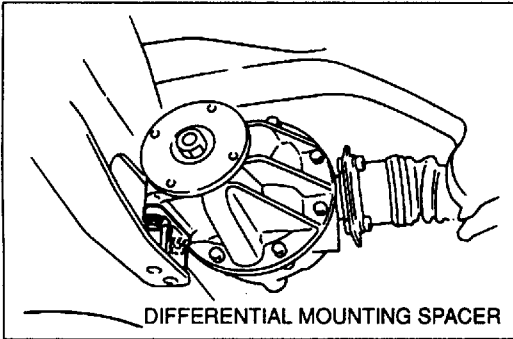

DIFFERENTIAL MOUNTING SPACER

45U0JX-054

**Power plant frame (PPF)**

1. Install the differential mounting spacer.

**Tightening torque:**

38—51 N·m {3.8—5.3 kgf·m, 28—38 ft·lbf}

2. Support the transmission with a jack so that it is level.
3. Position the PPF and tighten the transmission-side bolts by hand.
4. Verify that the sleeve is installed into the block.

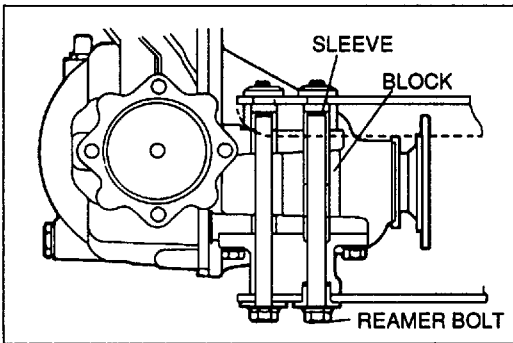

SLEEVE

BLOCK

REAMER BOLT

45U0MX-055

5. Install the spacer and reamer bolts in the forward hole, then hand tighten them.

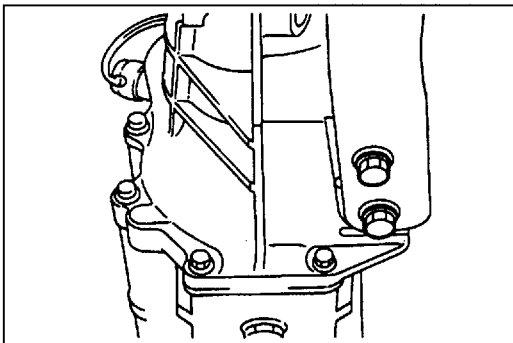

35U0JX-024

6. Snugly install the power plant frame bracket.
7. Tighten the transmission-side bolts.

**Tightening torque:**

104—123 N·m {10.6—12.6 kgf·m, 76.7—91.1 ft·lbf}

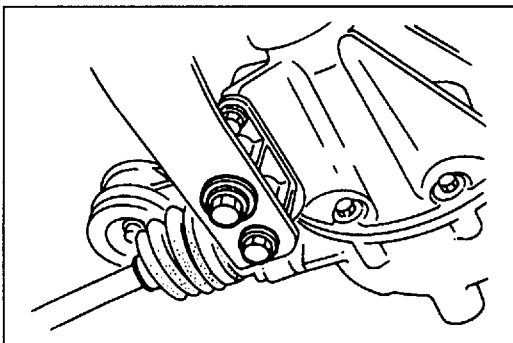

35U0JX-025

8. Tighten the differential-side bolts.

**Tightening torque:**

104—123 N·m {10.6—12.6 kgf·m, 76.7—91.1 ft·lbf}